

PLAN (1 : 15)

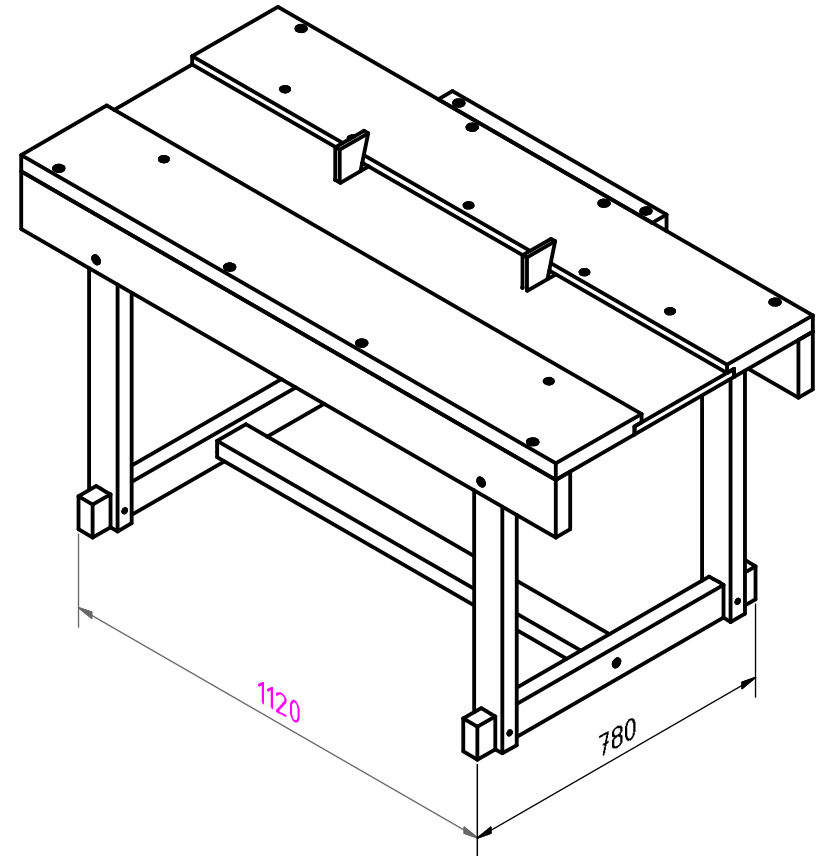

A-A (1 : 15)

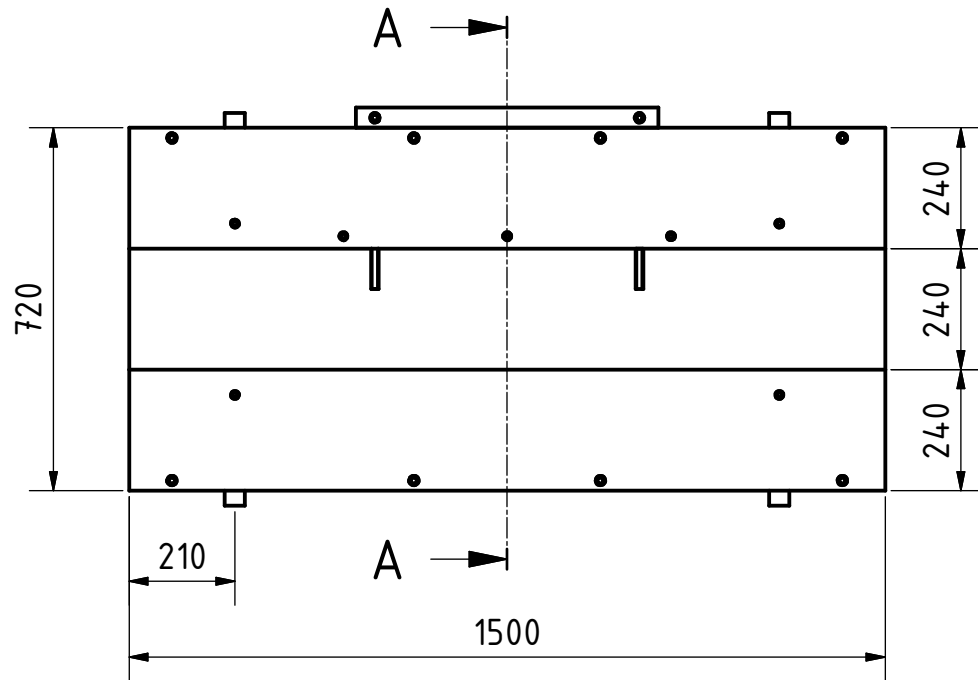
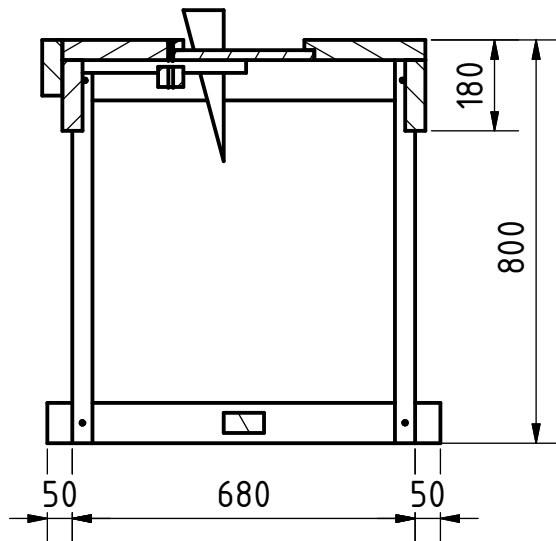

Hinweis: Alle Einheiten in mm.

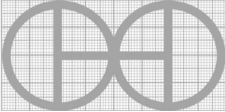
PROJEKT	ERSTELLT VON	GENEHMIGT VON	DATE	VERSION
Holz Werkbank mit Schraubstock	J. Zeron	A. Morillo	24/06/2021	1.0
TEIL-NAME	DATEI-NAME			TEIL-CODE
3d Ansichten	pac_wwb_woodworking-bench.iam			A1
ENTWICKELT VON	UMGESTALTET VON	DOK. TYP	WERKSTOFF	MENGE
		Assembly		
Practical Action	OHO e.V.	LIZENZ	SCALE	SEITE
		CC-BY-SA 4.0	1:15	1 /21

SIDE (1 : 15)

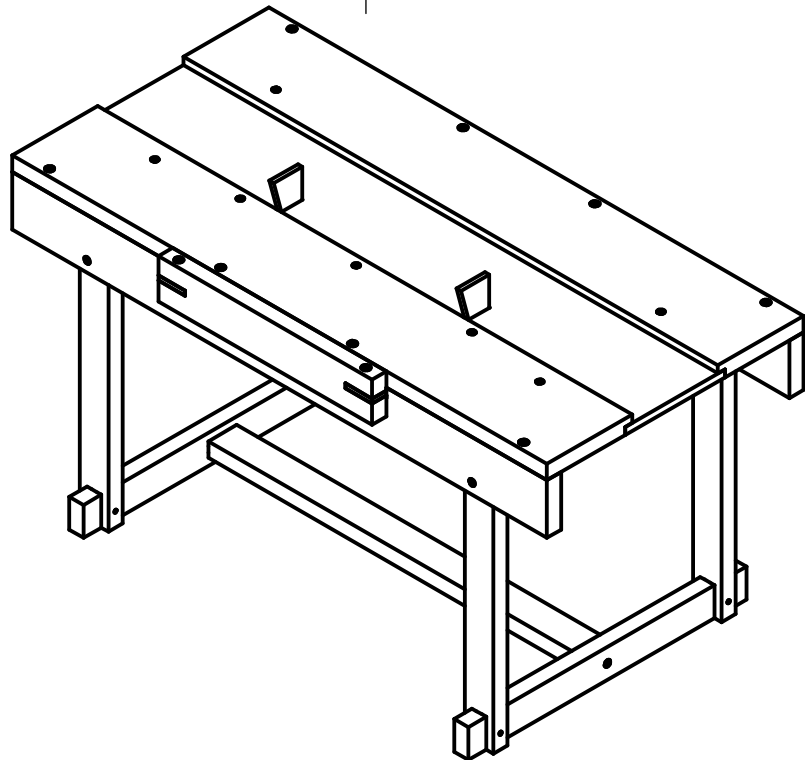
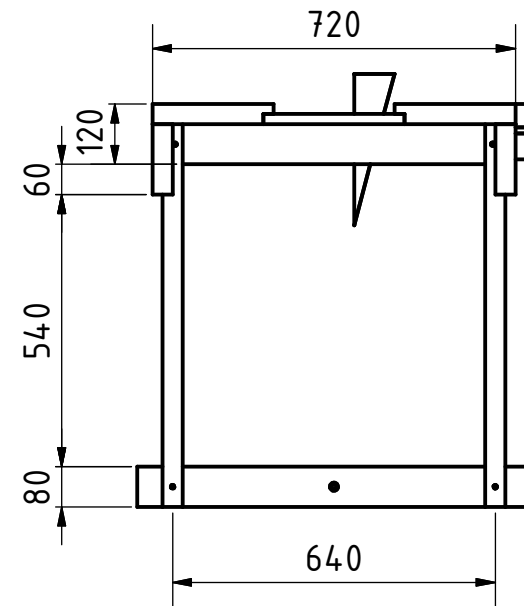
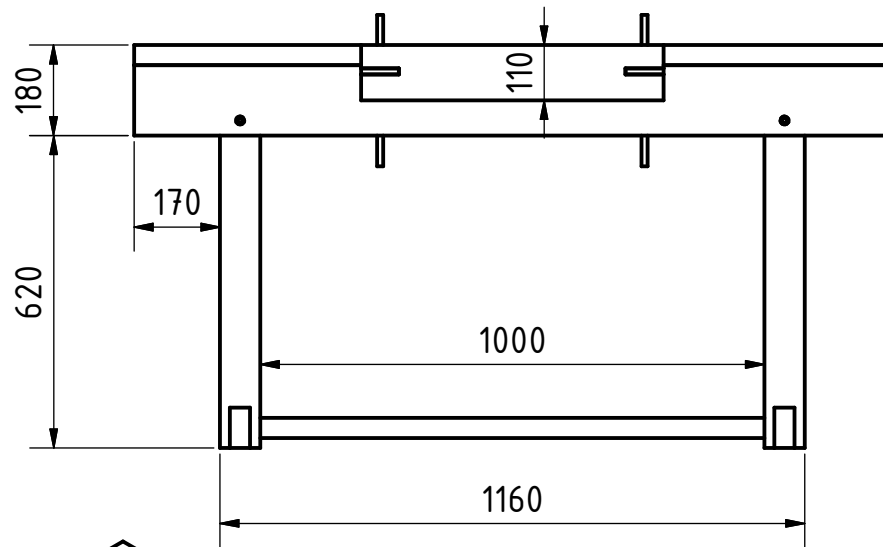

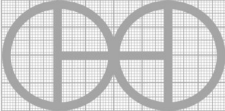
PROJEKT	ERSTELLT VON	GENEHMIGT VON	DATE	VERSION
Holz Werkbank mit Schraubstock	J. Zeron	A. Morillo	24/06/2021	1.0
TEIL-NAME	DATEI-NAME			TEIL-CODE
3d-Ansichten	pac_wwb_woodworking-bench.iam			A1
ENTWICKELT VON	UMGESTALTET VON	DOK. TYP	WERKSTOFF	MENGE
		Assembly		
Practical Action	OHO e.V.	LIZENZ	SCALE	SEITE
		CC-BY-SA 4.0	1:15	2 /21

EXPLOSION (1 : 20)

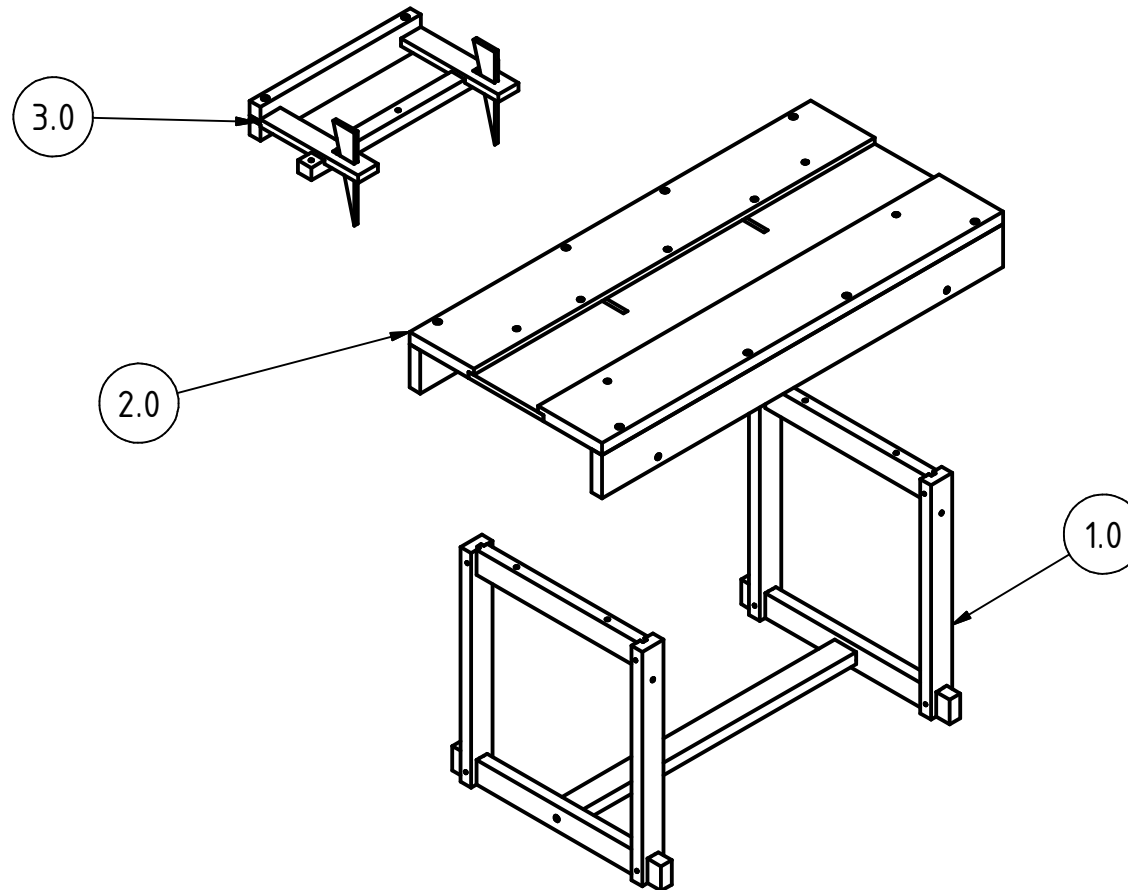

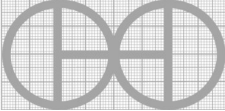
PROJEKT	ERSTELLT VON	GENEHMIGT VON	DATE	VERSION
Holz Werkbank mit Schraubstock	J. Zeron	A. Morillo	24/06/2021	1.0
TEIL-NAME	DATEI-NAME			TEIL-CODE
3d-Explosionszeichnungen	pac_wwb_woodworking-bench.ipn			A2
ENTWICKELT VON	UMGESTALTET VON	DOK. TYP	WERKSTOFF	MENGE
		Assembly		
Practical Action	OHO e.V.	LIZENZ	SCALE	SEITE
		CC-BY-SA 4.0	1:20	3 /21

PARTS LIST

POS	QTY	TEIL NAME	DATEI-NAME	TEIL-TYP	SPEZIFIKATIONEN	SEITE
A1	-	3d-Ansichten	pac_wwb_woodworking-bench.iam			2
A1	-	3d-Ansichten	pac_wwb_woodworking-bench.iam	Assembly	-	2
A2	-	3d-Explosionszeichnungen	pac_wwb_woodworking-bench.ipn	Assembly	-	3
B1	-	Teileliste	pac_wwb_woodworking-bench.csv	-	-	4
C1	-	Technische Hinweise		-	-	5
1.0	-	Rahmen	Frame.ipn	Assembly	-	6
1.1	4	Bein	Leg.ipt	Production	Im Ofen getrocknetes Holz	7
1.2	2	Untere Schiene	Bottom rail.ipt	Production	Im Ofen getrocknetes Holz	8
1.3	2	Obere Schiene	Top rail.ipt	Production	Im Ofen getrocknetes Holz	9
1.4	1	Krankentrage	Stretcher rail.ipt	Production	Im Ofen getrocknetes Holz	10
1.5	2	Schraube	-	Buy	Schraube 4mm x 100mm	-
1.6	16	Nagel	-	Buy	2" Stahl Nagel	-
2.0	-	Top	Top.ipn	Assembly	-	11
2.1	1	Tischplatte 1	Bench top 1.ipt	Production	Im Ofen getrocknetes Holz	12
2.2	1	Tischplatte 1.1	Bench top 1.1.ipt	Production	Im Ofen getrocknetes Holz	13
2.3	1	Bank Top 2	Bench top 2.ipt	Production	Im Ofen getrocknetes Holz	14
2.4	1	Tischplatte 2.1	Bench top 2.1.ipt	Production	Im Ofen getrocknetes Holz	15
2.5	1	Mitteltafel	Center panel.ipt	Production	Im Ofen getrocknetes Holz	16
2.6	8	Schraube 1	-	Buy	Schraube 5mm x 125mm	-
2.7	4	Schraube 2	-	Buy	Schraube 4mm x 125mm	-
2.8	4	Schraube 3	-	Buy	Schraube 4mm x 75mm	-
2.9	3	Schraube	-	Buy	Schraube 4mm x 100mm	-
3.0	-	Kiefer	Jaw.ipn	Assembly	-	17
3.1	1	Kiefer 1	Jaw 1.ipt	Production	Im Ofen getrocknetes Holz	18
3.2	2	Kiefer 2	Jaw 2.ipt	Production	Im Ofen getrocknetes Holz	19
3.3	1	Kieferführer	Jaw guide.ipt	Production	Im Ofen getrocknetes Holz	20
3.4	2	Keil	Wedge.ipt	Production	Im Ofen getrocknetes Holz	21
3.5	2	Schraube 4	-	Buy	Schraube 5mm x 100mm	-

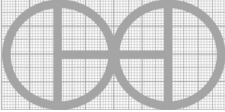
PROJEKT	ERSTELLT VON	GENEHMIGT VON	DATE	VERSION
Holz Werkbank mit Schraubstock	J. Zeron	A. Morillo	24/06/2021	1.0
TEIL-NAME	DATEI-NAME	TEIL-CODE		
Teileliste	pac_wwb_woodworking-bench.csv	B1		
ENTWICKELT VON	UMGESTALTET VON	DOK. TYP	WERKSTOFF	MENGE
		Parts list		
Practical Action	OHO e.V.	LIZENZ	SCALE	SEITE
		CC-BY-SA 4.0		4 /21

TECHNISCHE ANMERKUNGEN

ANMERKUNGEN	INHALT
ALLGEMEINE ANMERKUNGEN	
Behandlung von Holz	<ul style="list-style-type: none"> - Das Holz muss mit Pestiziden behandelt und in der Trockenkammer getrocknet werden, um eine ausreichende Feuchtigkeit zu gewährleisten. - Für die spätere Verwendung sollte ein Holzschutzmittel aufgetragen werden. - Verwenden Sie Weißleim, um die Teile vor dem Verschrauben zu verbinden.

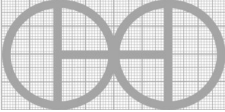
PROJEKT Holz Werkbank mit Schraubstock	ERSTELLT VON J. Zeron	GENEHMIGT VON A. Morillo	DATE 24/06/2021	VERSION 1.0
TEIL-NAME Technische Hinweise	DATEI-NAME			TEIL-CODE C1
ENTWICKELT VON	UMGESTALTET VON 	DOK. TYP Technical notes	WERKSTOFF	MENGE -
Practical Action	OHO e.V.	LIZENZ CC-BY-SA 4.0	SCALE	SEITE 5 /21

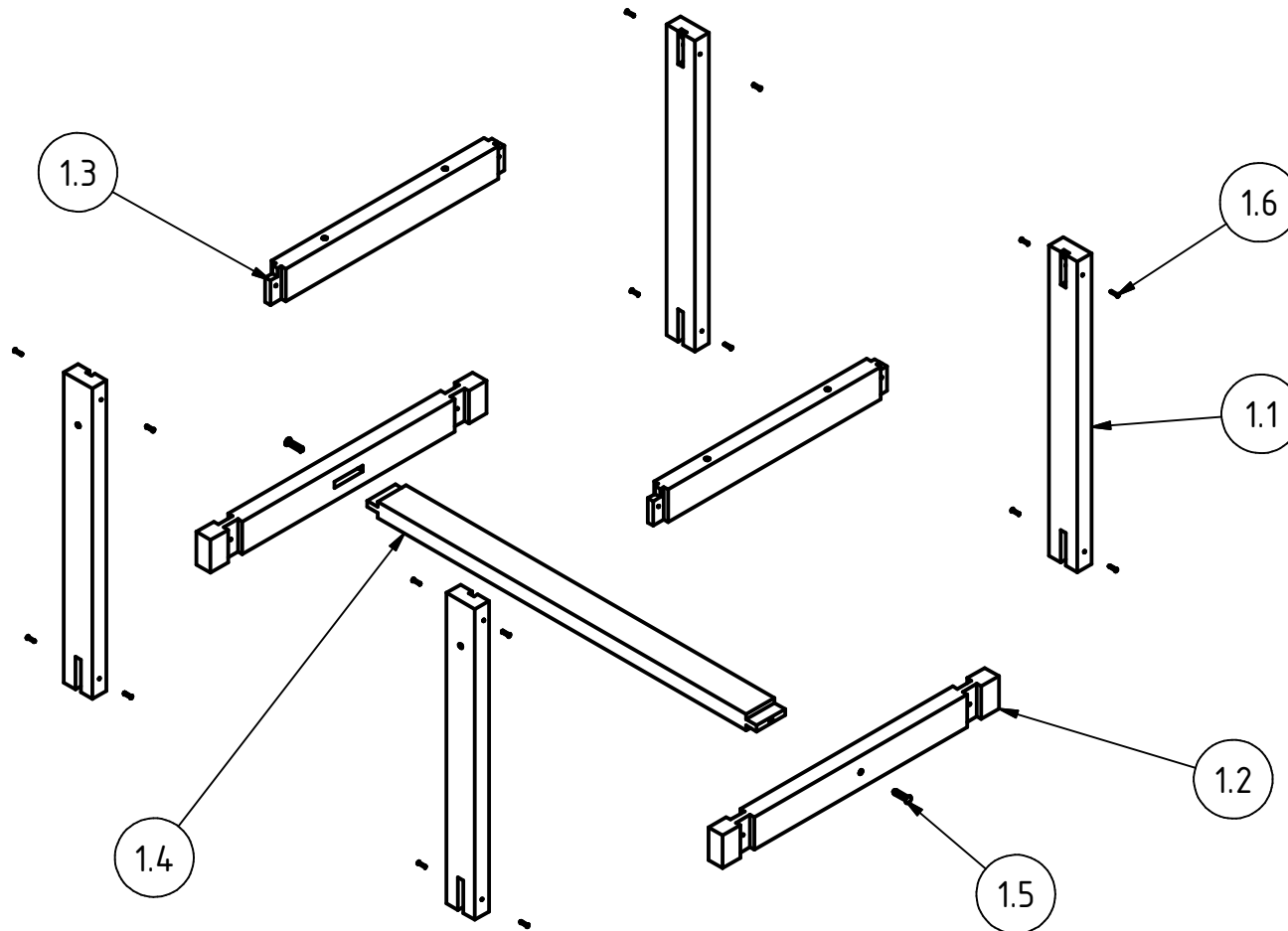

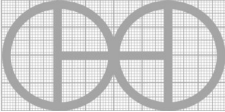
PROJEKT	ERSTELLT VON	GENEHMIGT VON	DATE	VERSION
Holz Werkbank mit Schraubstock	J. Zeron	A. Morillo	24/06/2021	1.0
TEIL-NAME	DATEI-NAME			TEIL-CODE
Rahmen	Frame.ipn			1.0
ENTWICKELT VON	UMGESTALTET VON	DOK. TYP	WERKSTOFF	MENGE
		Assembly		
Practical Action	OHO e.V.	LIZENZ	SCALE	SEITE
		CC-BY-SA 4.0	1:15	6 /21

ELEVATION (1 : 8)

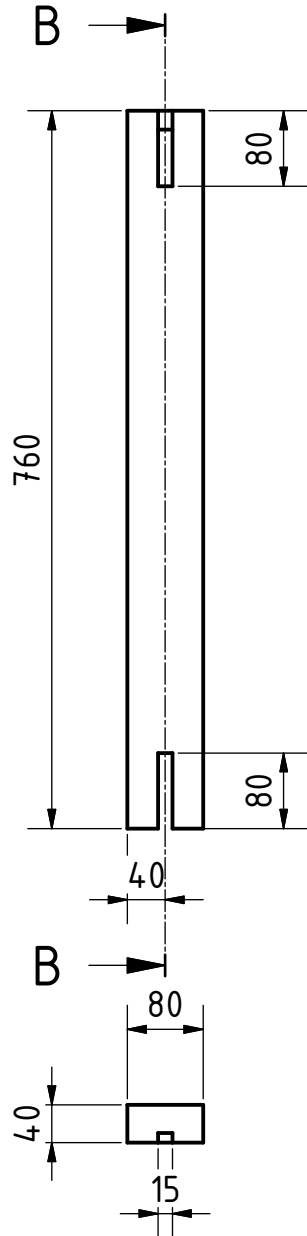

B-B (1 : 8)

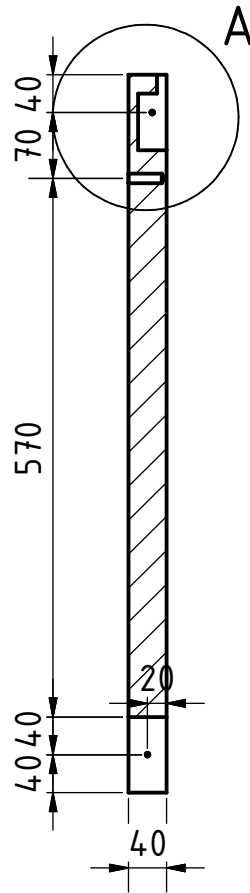

A (1 : 4)

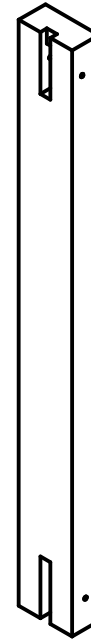
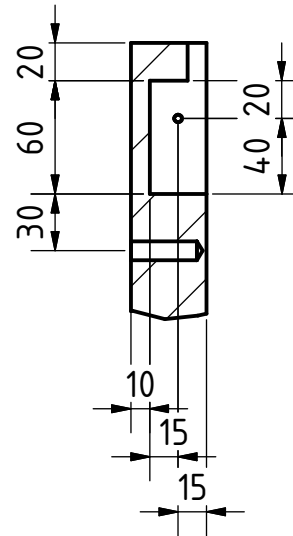

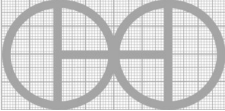
PROJEKT	ERSTELLT VON	GENEHMIGT VON	DATE	VERSION
Holz Werkbank mit Schraubstock	J. Zeron	A. Morillo	24/06/2021	1.0
TEIL-NAME	DATEI-NAME			TEIL-CODE
Bein	Leg.ipt			1.1
ENTWICKELT VON	UMGESTALTET VON	DOK. TYP	WERKSTOFF	MENGE
		Part	Im Ofen getrocknetes Holz	4
Practical Action	OHO e.V.	LIZENZ	SCALE	SEITE
		CC-BY-SA 4.0	1:8	7 /21

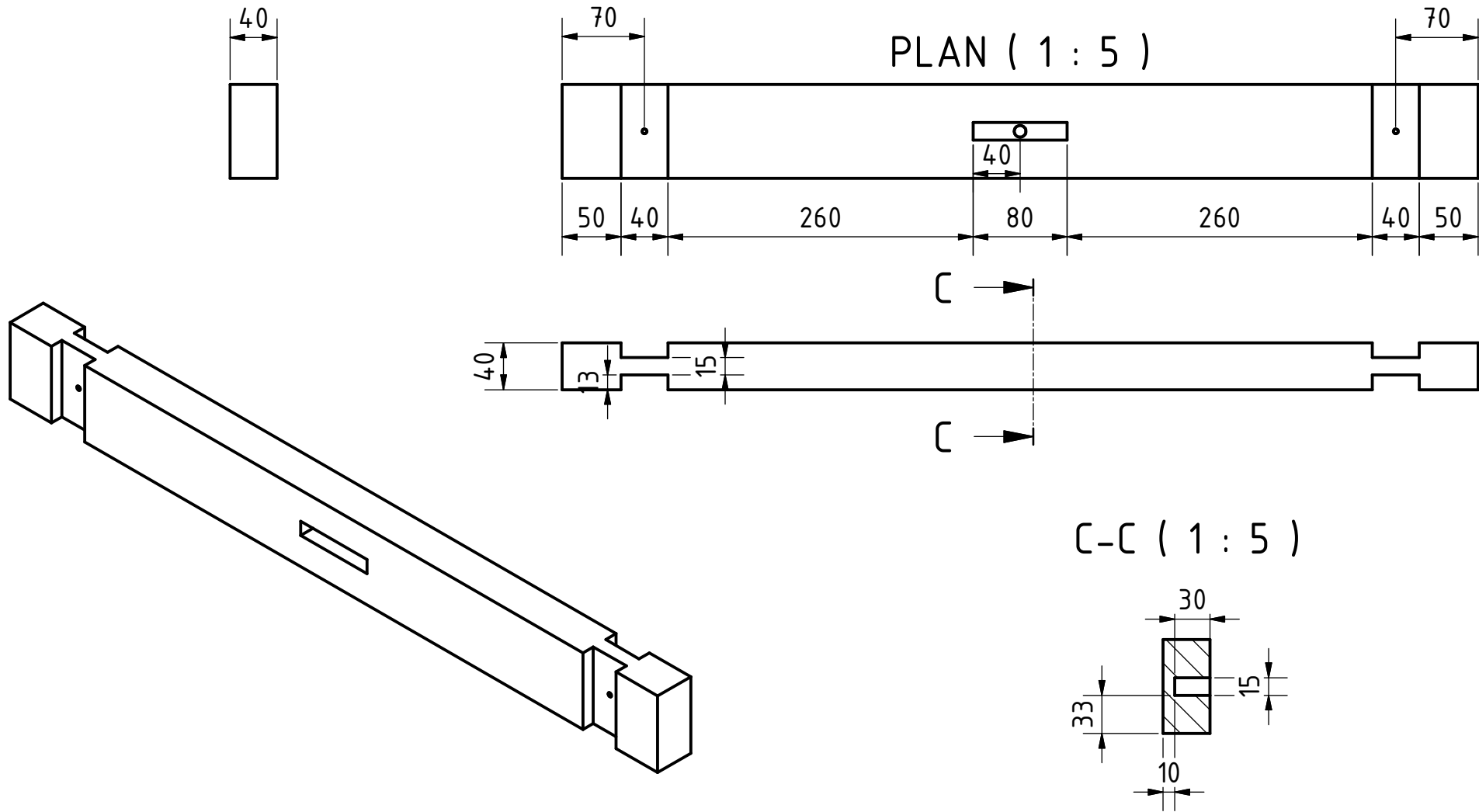

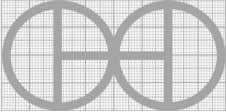
PROJEKT	ERSTELLT VON	GENEHMIGT VON	DATE	VERSION
Holz Werkbank mit Schraubstock	J. Zeron	A. Morillo	24/06/2021	1.0
TEIL-NAME	DATEI-NAME			TEIL-CODE
Untere Schiene	Bottom rail.ipt			1.2
ENTWICKELT VON	UMGESTALTET VON	DOK. TYP	WERKSTOFF	MENGE
		Part	Im Ofen getrocknetes Holz	2
Practical Action	OHO e.V.	LIZENZ	SCALE	SEITE
		CC-BY-SA 4.0	1:5	8 /21

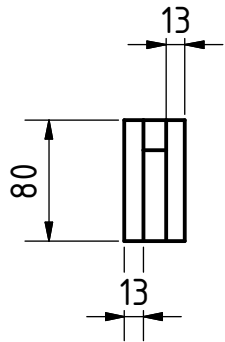

ELEVATION (1 : 5)

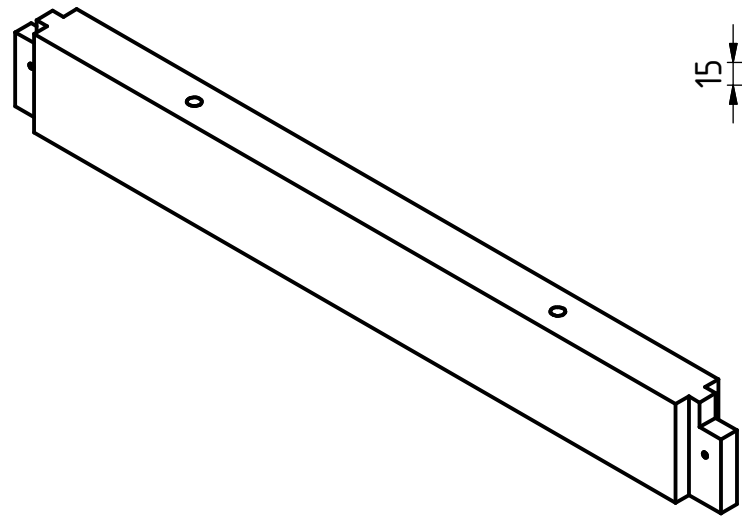
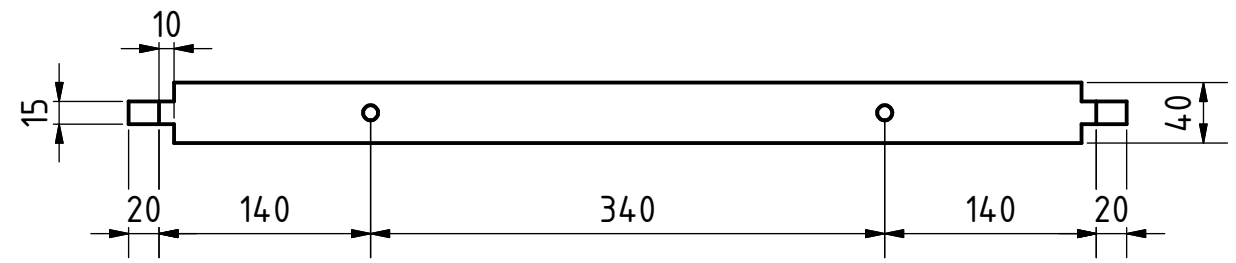
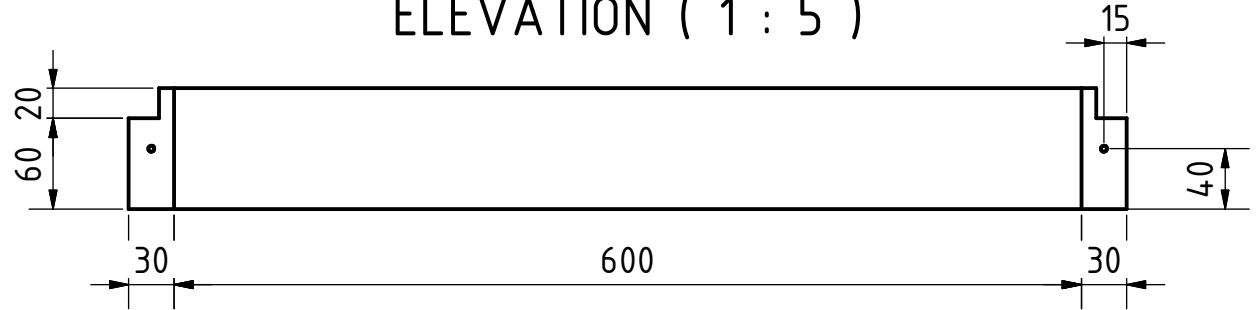

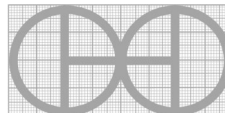
PROJEKT	ERSTELLT VON	GENEHMIGT VON	DATE	VERSION
Holz Werkbank mit Schraubstock	J. Zeron	A. Morillo	24/06/2021	1.0
TEIL-NAME	DATEI-NAME			TEIL-CODE
Obere Schiene	Top rail.ipt			1.3
ENTWICKELT VON	UMGESTALTET VON	DOK. TYP	WERKSTOFF	MENGE
		Part	Im Ofen getrocknetes Holz	2
Practical Action	OHO e.V.	LIZENZ	SCALE	SEITE
		CC-BY-SA 4.0	1:5	9 /21

PLAN (1 : 8)

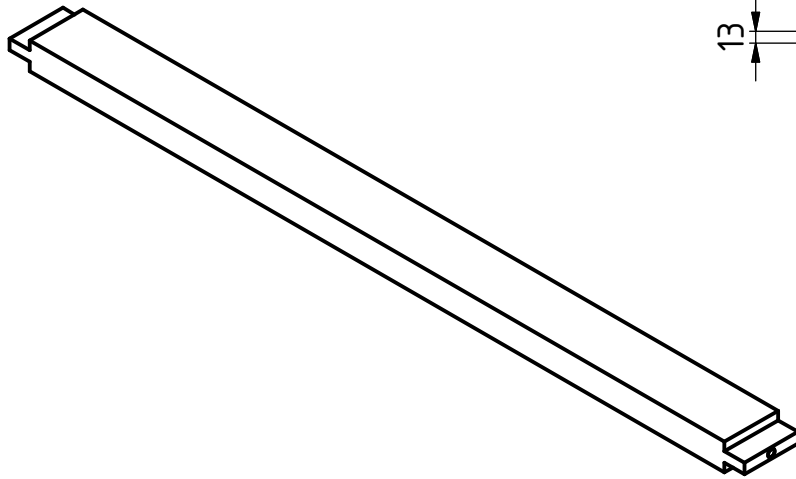
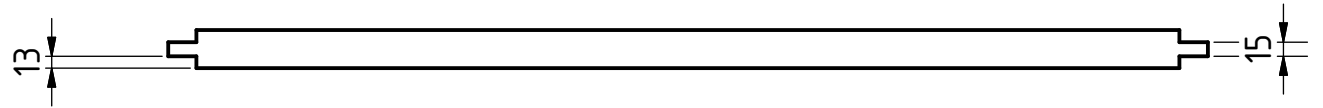
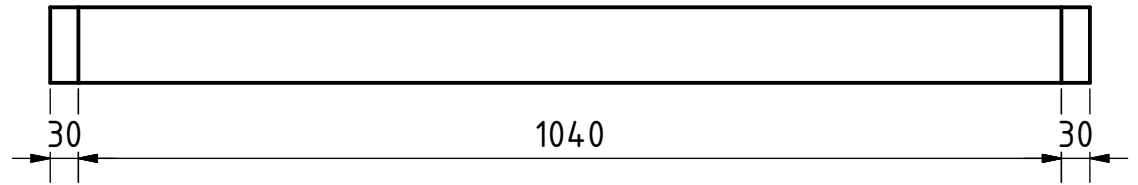
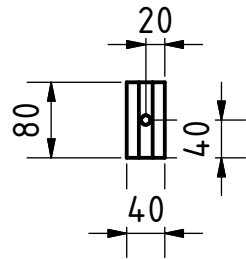

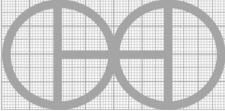
PROJEKT	ERSTELLT VON	GENEHMIGT VON	DATE	VERSION
Holz Werkbank mit Schraubstock	J. Zeron	A. Morillo	24/06/2021	1.0
TEIL-NAME	DATEI-NAME			TEIL-CODE
Krankentrage	Stretcher rail.ipt			1.4
ENTWICKELT VON	UMGESTALTET VON	DOK. TYP	WERKSTOFF	MENGE
		Part	Im Ofen getrocknetes Holz	1
Practical Action	OHO e.V.	LIZENZ	SCALE	SEITE
		CC-BY-SA 4.0	1:8	10 /21

EXPLOSION (1 : 15)

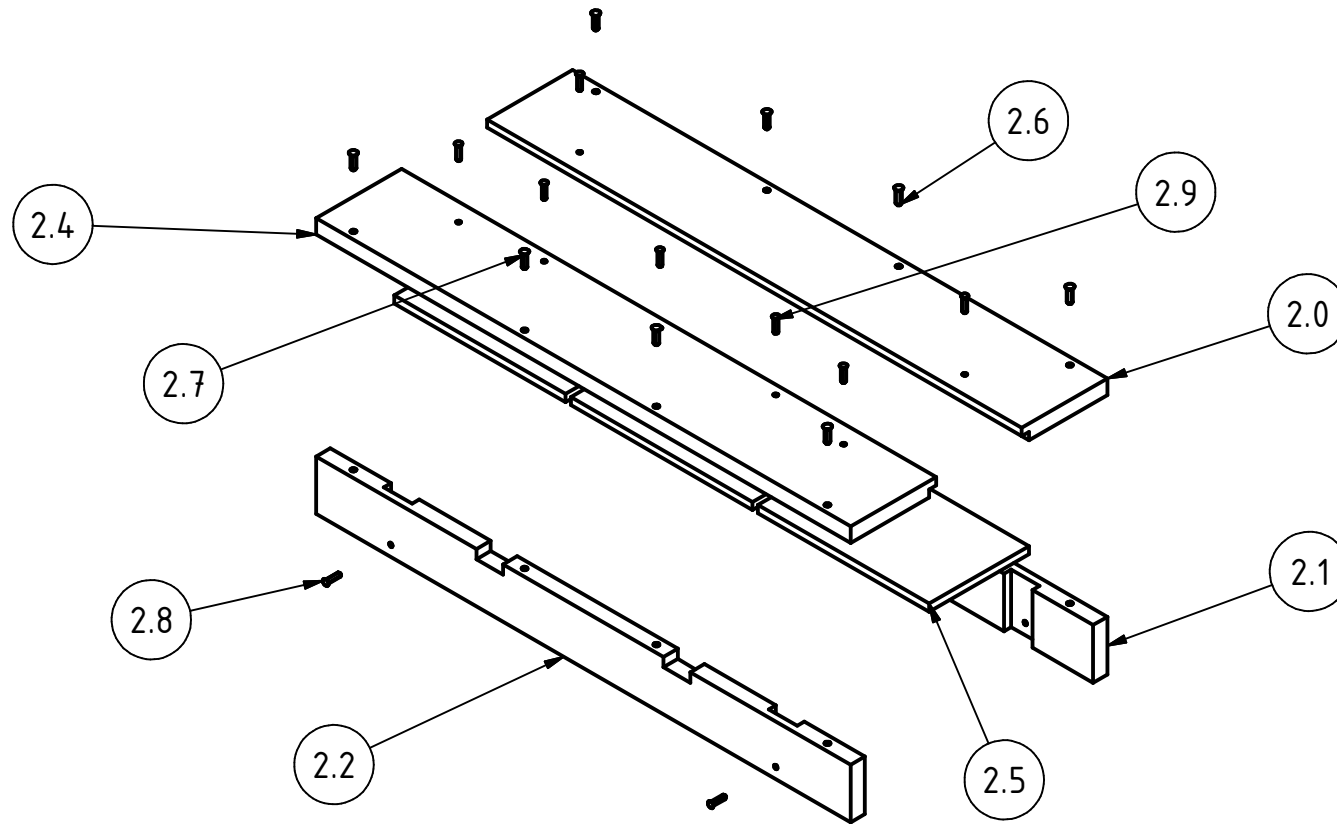

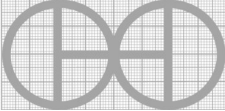
PROJEKT	ERSTELLT VON	GENEHMIGT VON	DATE	VERSION
Holz Werkbank mit Schraubstock	J. Zeron	A. Morillo	24/06/2021	1.0
TEIL-NAME	DATEI-NAME			TEIL-CODE
Top	Top.ipn			2.0
ENTWICKELT VON	UMGESTALTET VON	DOK. TYP	WERKSTOFF	MENGE
		Assembly		
Practical Action	OHO e.V.	LIZENZ	SCALE	SEITE
		CC-BY-SA 4.0	1:15	11 /21

ELEVATION (1 : 10)

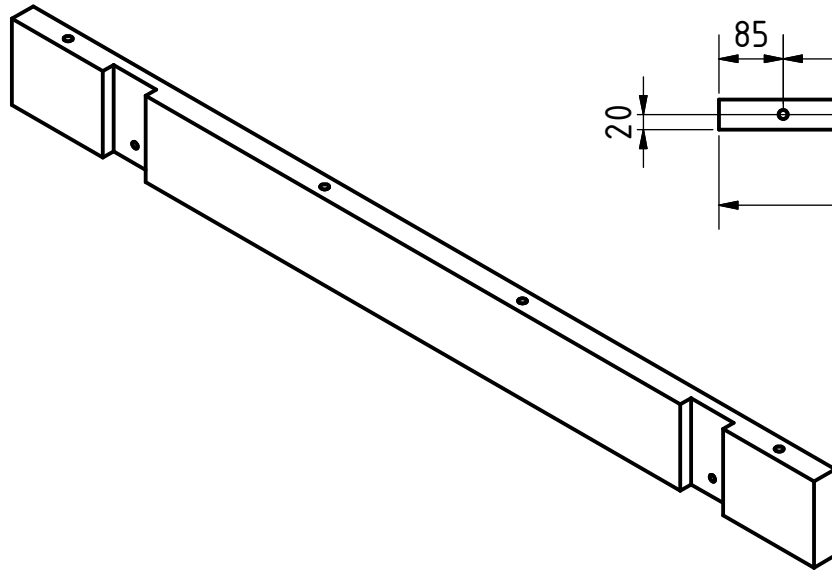
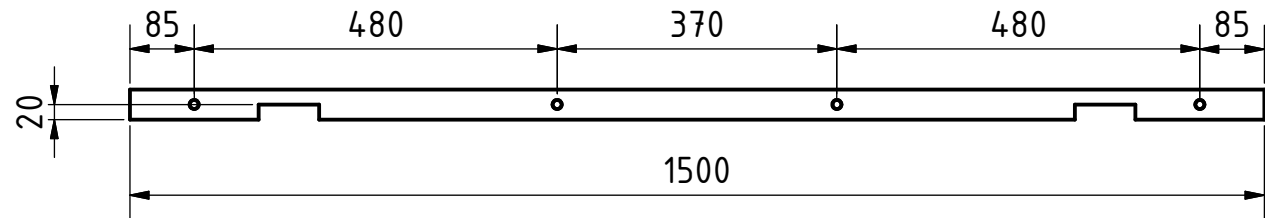
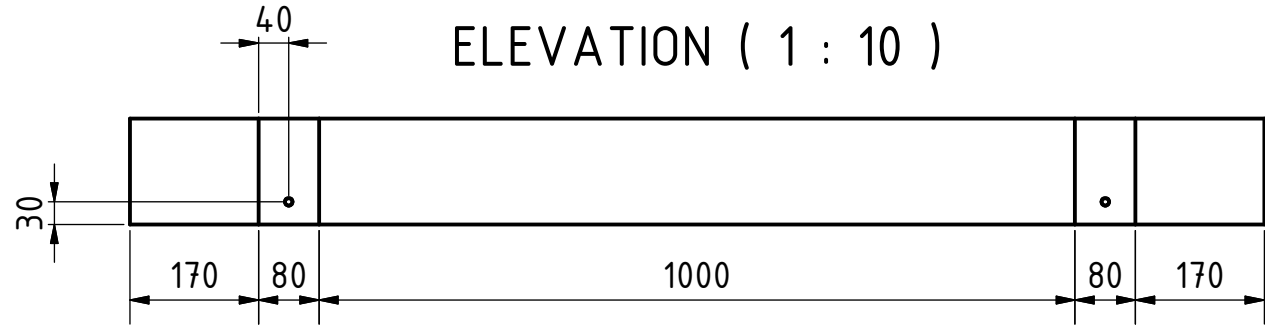
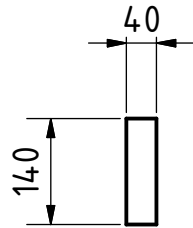

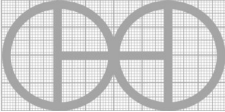
PROJEKT	ERSTELLT VON	GENEHMIGT VON	DATE	VERSION
Holz Werkbank mit Schraubstock	J. Zeron	A. Morillo	24/06/2021	1.0
TEIL-NAME	DATEI-NAME			TEIL-CODE
Tischplatte 1	Bench top 1.ipt			2.1
ENTWICKELT VON	UMGESTALTET VON	DOK. TYP	WERKSTOFF	MENGE
		Part	Im Ofen getrocknetes Holz	1
Practical Action	OHO e.V.	LIZENZ	SCALE	SEITE
		CC-BY-SA 4.0	1:10	12 /21

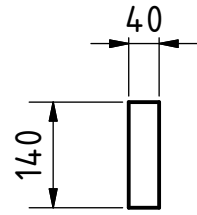

ELEVATION (1 : 10)

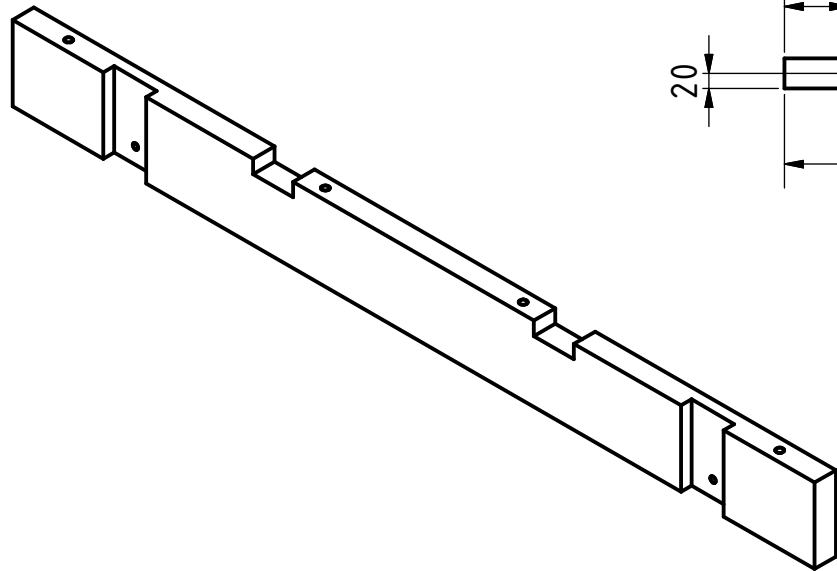
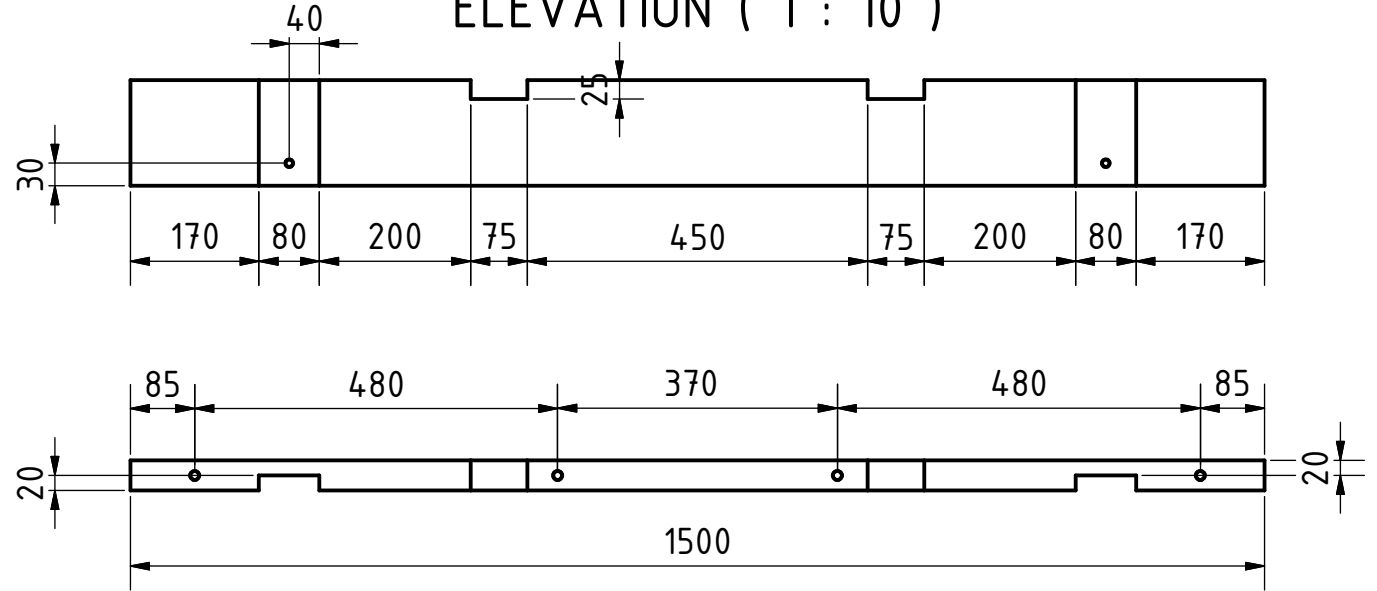

PROJEKT	ERSTELLT VON	GENEHMIGT VON	DATE	VERSION
Holz Werkbank mit Schraubstock	J. Zeron	A. Morillo	24/06/2021	1.0
TEIL-NAME	DATEI-NAME			TEIL-CODE
Tischplatte 1.1	Bench top 1.1.ipt			2.2
ENTWICKELT VON	UMGESTALTET VON	DOK. TYP	WERKSTOFF	MENGE
		Part	Im Ofen getrocknetes Holz	1
Practical Action	OHO e.V.	LIZENZ	SCALE	SEITE
		CC-BY-SA 4.0	1:10	13 /21

PLAN (1 : 10)

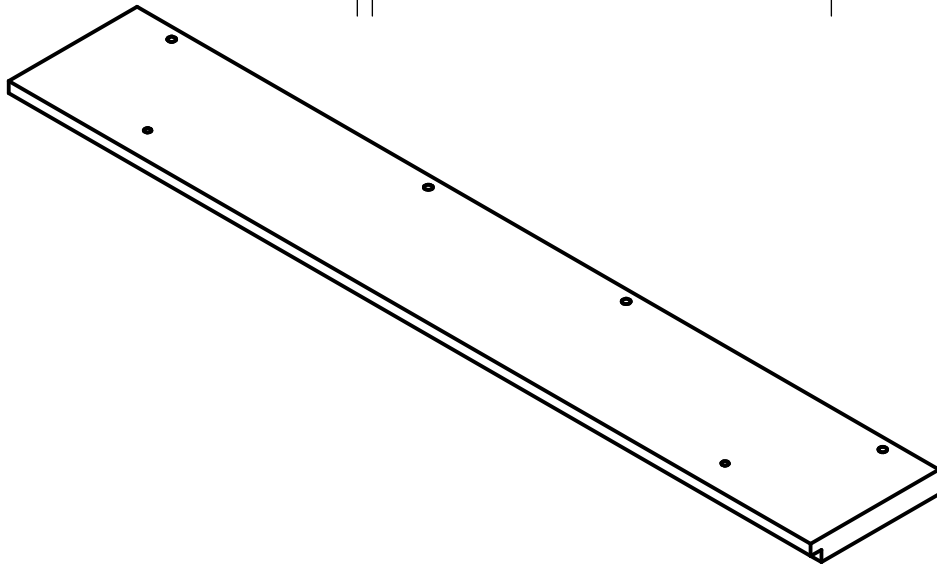
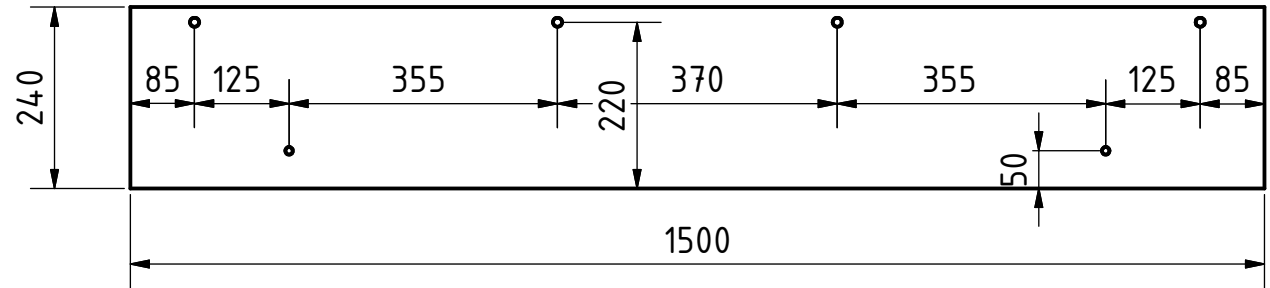
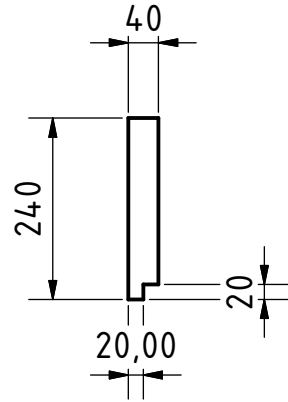

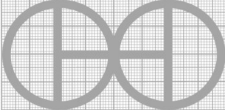
PROJEKT	ERSTELLT VON	GENEHMIGT VON	DATE	VERSION
Holz Werkbank mit Schraubstock	J. Zeron	A. Morillo	24/06/2021	1.0
TEIL-NAME	DATEI-NAME			TEIL-CODE
Bank Top 2	Bench top 2.ipt			2.3
ENTWICKELT VON	UMGESTALTET VON	DOK. TYP	WERKSTOFF	MENGE
		Part	Im Ofen getrocknetes Holz	1
Practical Action	OHO e.V.	LIZENZ	SCALE	SEITE
		CC-BY-SA 4.0	1:10	14 /21

PLAN (1 : 10)

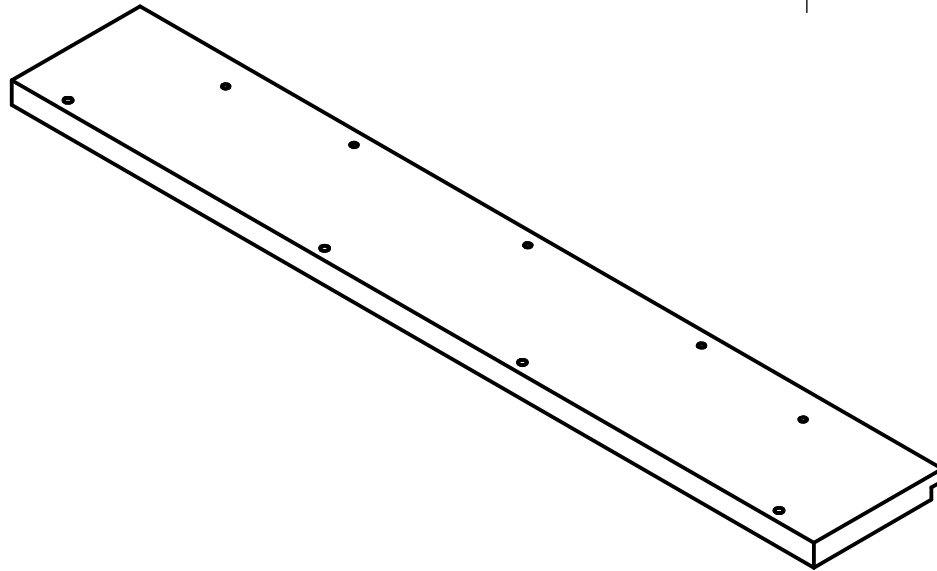
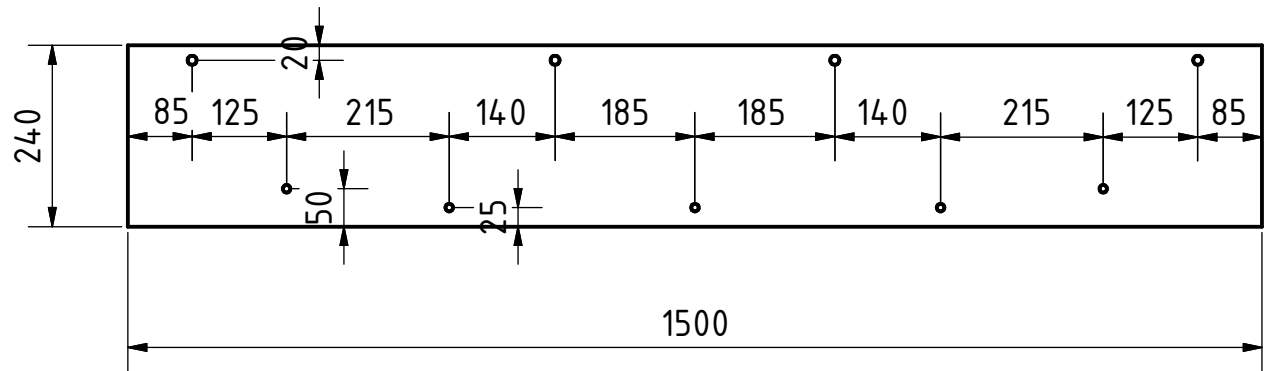
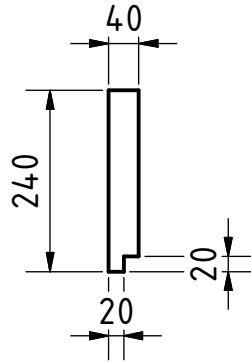

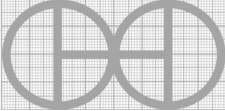
PROJEKT	ERSTELLT VON	GENEHMIGT VON	DATE	VERSION
Holz Werkbank mit Schraubstock	J. Zeron	A. Morillo	24/06/2021	1.0
TEIL-NAME	DATEI-NAME			TEIL-CODE
Tischplatte 2.1	Bench top 2.1.ipt			2.4
ENTWICKELT VON	UMGESTALTET VON	DOK. TYP	WERKSTOFF	MENGE
		Part	Im Ofen getrocknetes Holz	1
Practical Action	OHO e.V.	LIZENZ	SCALE	SEITE
		CC-BY-SA 4.0	1:10	15 /21

PLAN (1 : 10)

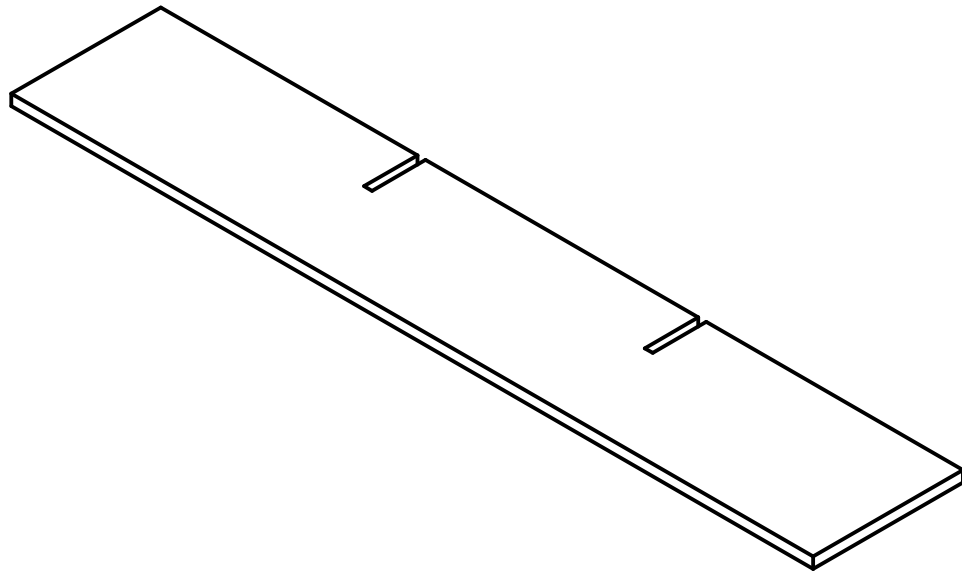
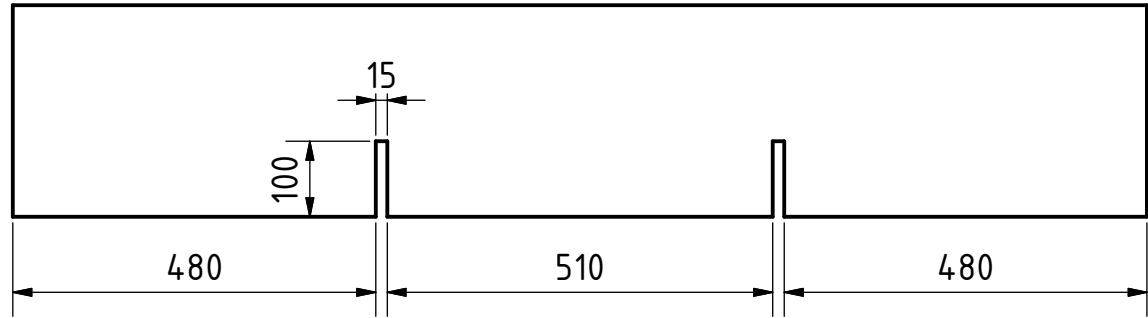
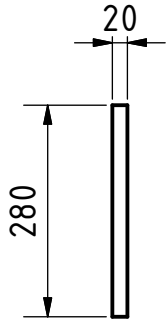

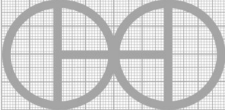
PROJEKT	ERSTELLT VON	GENEHMIGT VON	DATE	VERSION
Holz Werkbank mit Schraubstock	J. Zeron	A. Morillo	24/06/2021	1.0
TEIL-NAME	DATEI-NAME			TEIL-CODE
Mitteltafel	Center panel.ipt			2.5
ENTWICKELT VON	UMGESTALTET VON	DOK. TYP	WERKSTOFF	MENGE
		Part	Im Ofen getrocknetes Holz	1
Practical Action	OHO e.V.	LIZENZ	SCALE	SEITE
		CC-BY-SA 4.0	1:10	16 /21

EXPLOSION (1 : 10)

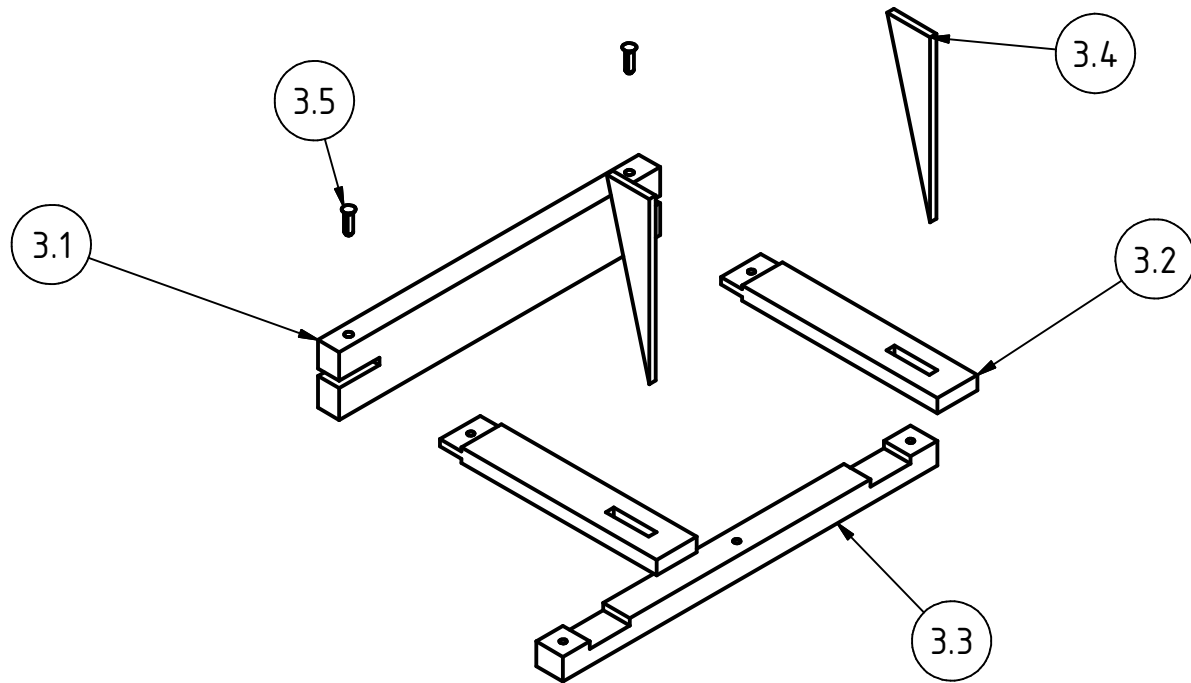

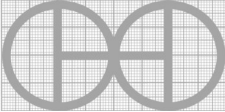
PROJEKT	ERSTELLT VON	GENEHMIGT VON	DATE	VERSION
Holz Werkbank mit Schraubstock	J. Zeron	A. Morillo	24/06/2021	1.0
TEIL-NAME	DATEI-NAME			TEIL-CODE
Kiefer	Jaw.ipn			3.0
ENTWICKELT VON	UMGESTALTET VON	DOK. TYP	WERKSTOFF	MENGE
		Assembly		
Practical Action	OHO e.V.	LIZENZ	SCALE	SEITE
		CC-BY-SA 4.0	1:10	17 /21

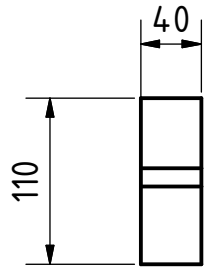

ELEVATION (1 : 5)

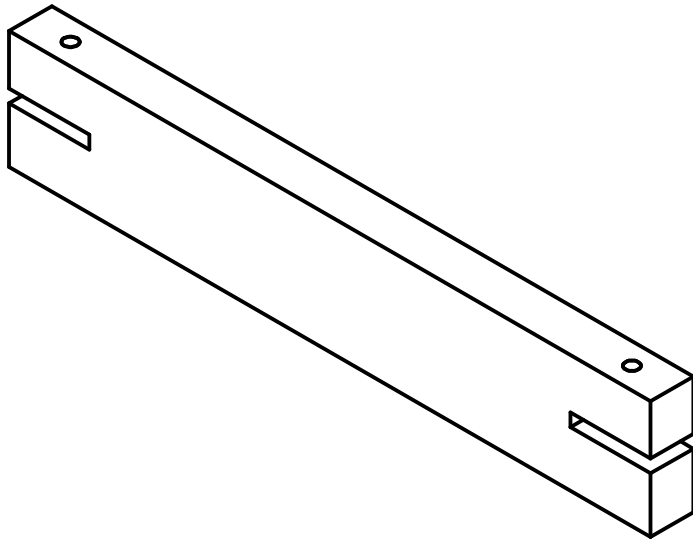
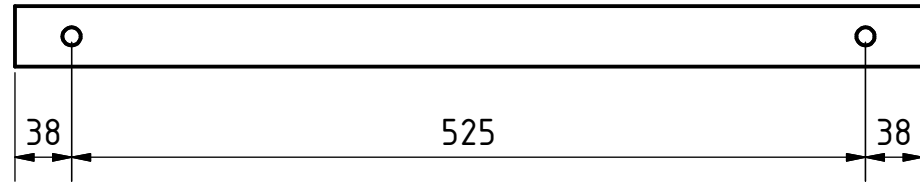
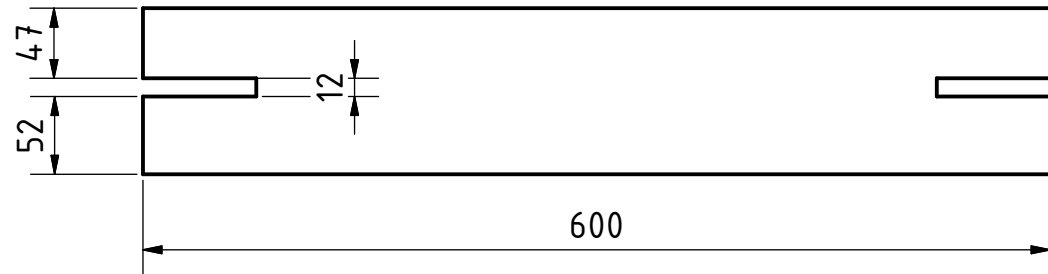

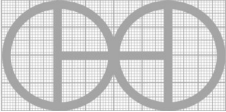
PROJEKT	ERSTELLT VON	GENEHMIGT VON	DATE	VERSION
Holz Werkbank mit Schraubstock	J. Zeron	A. Morillo	24/06/2021	1.0
TEIL-NAME	DATEI-NAME			TEIL-CODE
Kiefer 1	Jaw 1.ipt			3.1
ENTWICKELT VON	UMGESTALTET VON	DOK. TYP	WERKSTOFF	MENGE
		Part	Im Ofen getrocknetes Holz	1
Practical Action	OHO e.V.	LIZENZ	SCALE	SEITE
		CC-BY-SA 4.0	1:5	18 /21

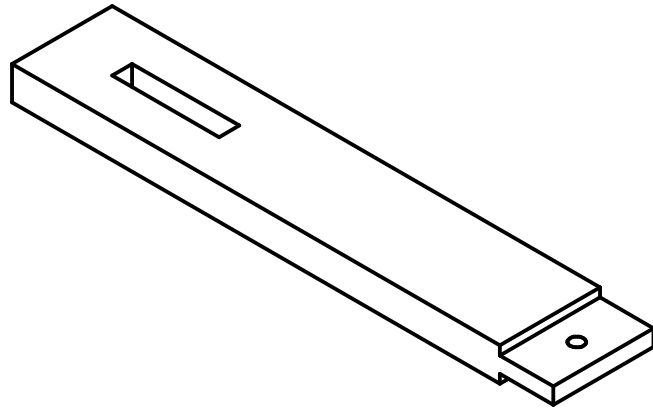
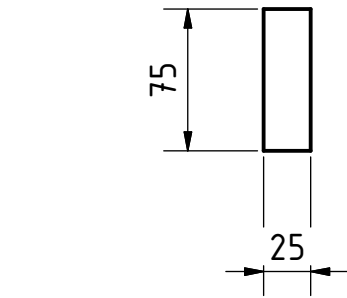

PLAN (1 : 4)

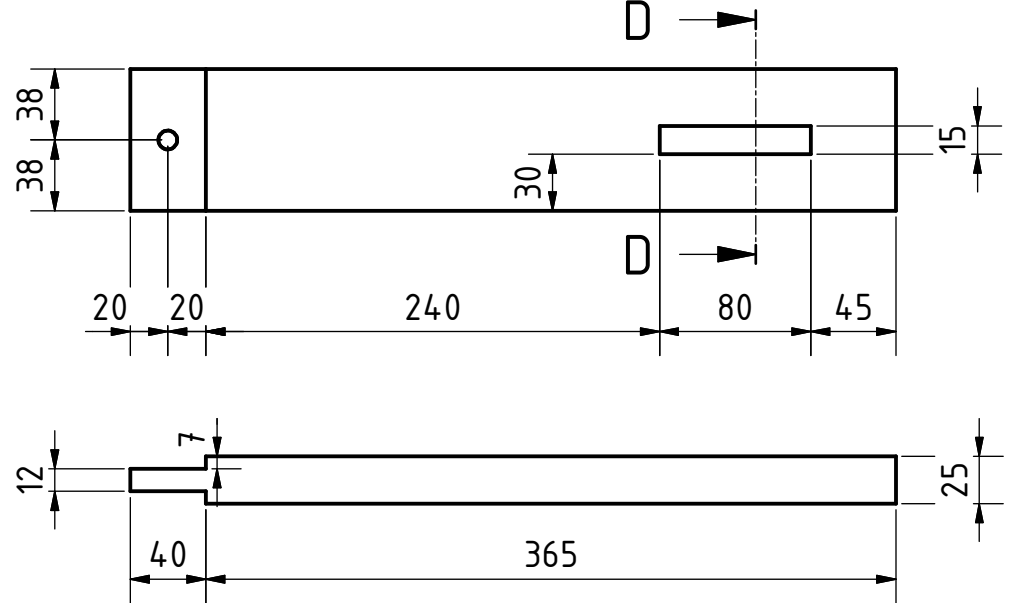

D-D (1 : 4)

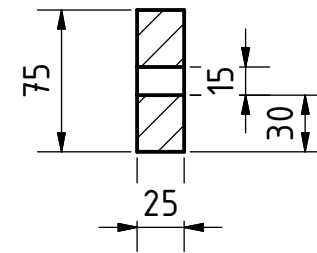

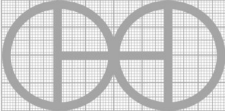
PROJEKT	ERSTELLT VON	GENEHMIGT VON	DATE	VERSION
Holz Werkbank mit Schraubstock	J. Zeron	A. Morillo	24/06/2021	1.0
TEIL-NAME	DATEI-NAME			TEIL-CODE
Kiefer 2	Jaw 2.ipt			3.2
ENTWICKELT VON	UMGESTALTET VON	DOK. TYP	WERKSTOFF	MENGE
		Part	Im Ofen getrocknetes Holz	2
Practical Action	OHO e.V.	LIZENZ	SCALE	SEITE
		CC-BY-SA 4.0	1:4	19 /21

PLAN (1 : 5)

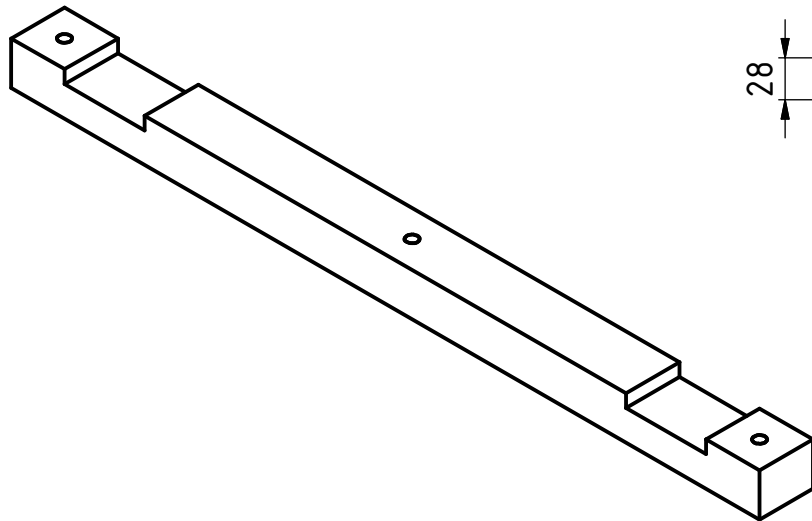
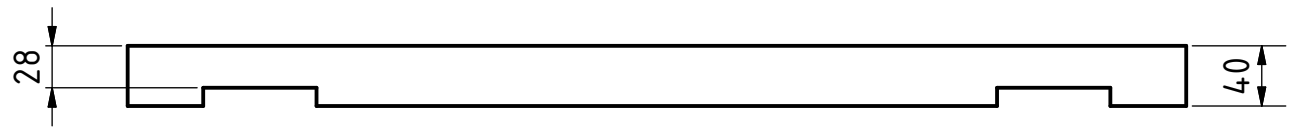
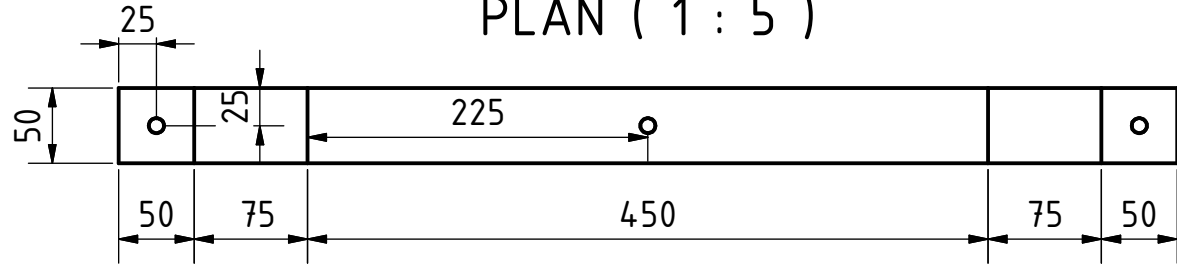
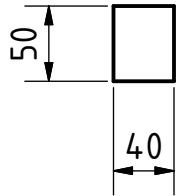

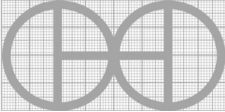
PROJEKT	ERSTELLT VON	GENEHMIGT VON	DATE	VERSION
Holz Werkbank mit Schraubstock	J. Zeron	A. Morillo	24/06/2021	1.0
TEIL-NAME	DATEI-NAME			TEIL-CODE
Kieferführer	Jaw guide.ipt			3.3
ENTWICKELT VON	UMGESTALTET VON	DOK. TYP	WERKSTOFF	MENGE
		Part	Im Ofen getrocknetes Holz	1
Practical Action	OHO e.V.	LIZENZ	SCALE	SEITE
		CC-BY-SA 4.0	1:5	20 /21

ELEVATION (1 : 4)

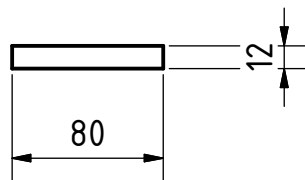
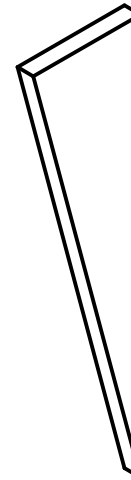
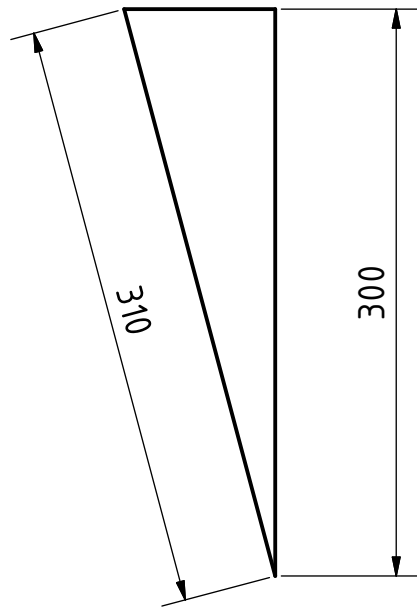

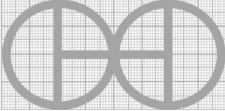
PROJEKT	ERSTELLT VON	GENEHMIGT VON	DATE	VERSION
Holz Werkbank mit Schraubstock	J. Zeron	A. Morillo	24/06/2021	1.0
TEIL-NAME	DATEI-NAME			TEIL-CODE
Keil	Wedge.ipt			3.4
ENTWICKELT VON	UMGESTALTET VON	DOK. TYP	WERKSTOFF	MENGE
		Part	Im Ofen getrocknetes Holz	2
Practical Action	OHO e.V.	LIZENZ	SCALE	SEITE
		CC-BY-SA 4.0	1:4	21 /21