

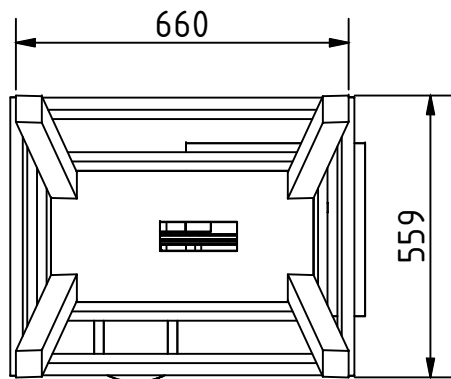

Note: All units in mm.

PROJECT	CREATED BY	APPROVED BY	DATE	VERSION
Bandsaw wheel - Dia 12 inch	E. Araujo	A. Morillo	13/09/2021	1.0
PART NAME	FILE NAME			POS
3D views	jah_bsw_bandsaw_wheel_-_dia_12_inch.dwg			A1
PUBLISHED BY	DOC. TYPE	MATERIAL	QUANTITY	
 OPEN HARDWARE OBSERVATORY Free Blueprints for Sustainable Development	Assembly		1	
	LICENCE	SCALE	SHEET	
OHO e.V.	CC-BY-SA 4.0	1:15	1/55	

Based on drawings of John A. Hoffmann, 1974

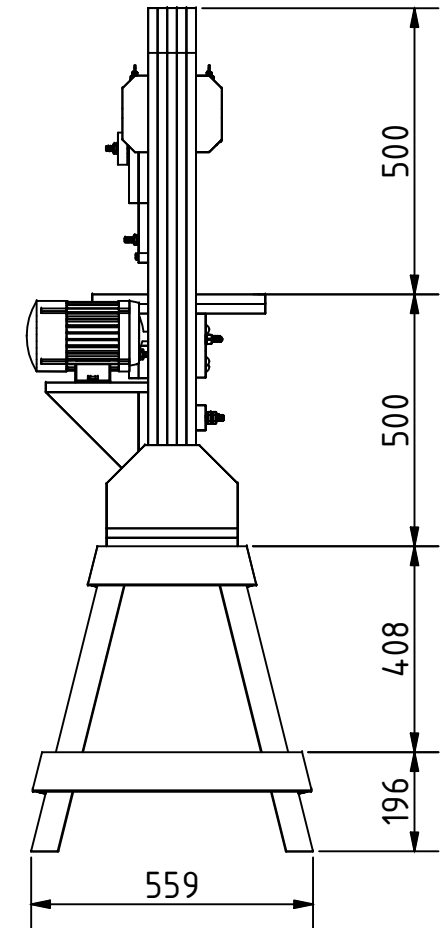
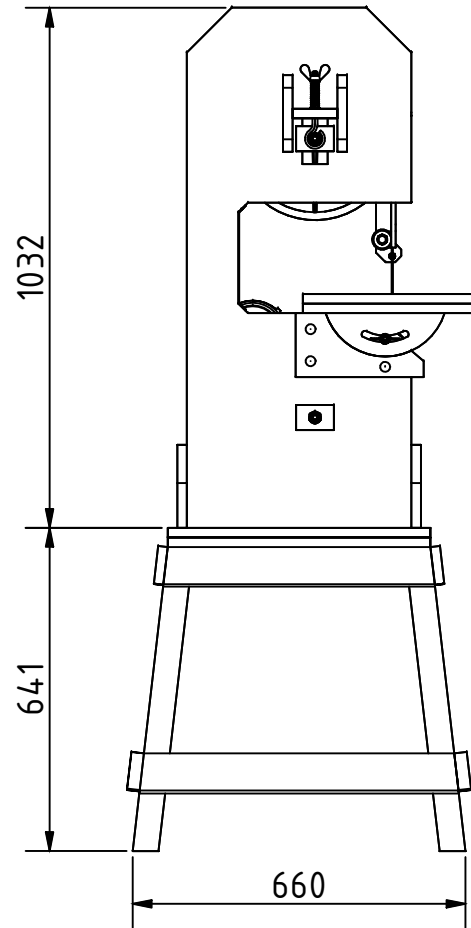
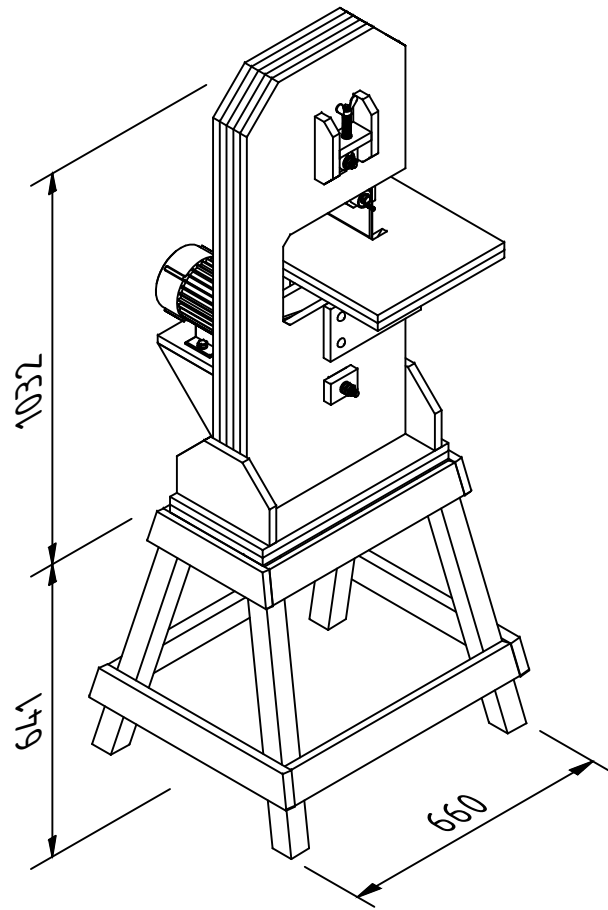

Note: All units in mm.

PROJECT	CREATED BY	APPROVED BY	DATE	VERSION
Bandsaw wheel - Dia 12 inch	E. Araujo	A. Morillo	13/09/2021	1.0
PART NAME	FILE NAME			POS
3D views	jah_bsw_bandsaw_wheel_-_dia_12_inch.dwg			A1
PUBLISHED BY	DOC. TYPE	MATERIAL	QUANTITY	
 OPEN HARDWARE OBSERVATORY Free Blueprints for Sustainable Development	Assembly		1	
	LICENCE	SCALE	SHEET	
OHO e.V.	CC-BY-SA 4.0	1:15	2/55	

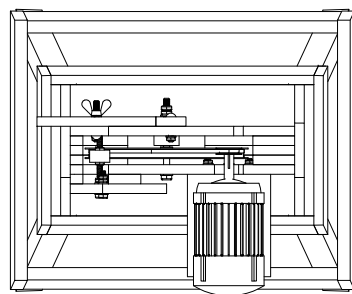
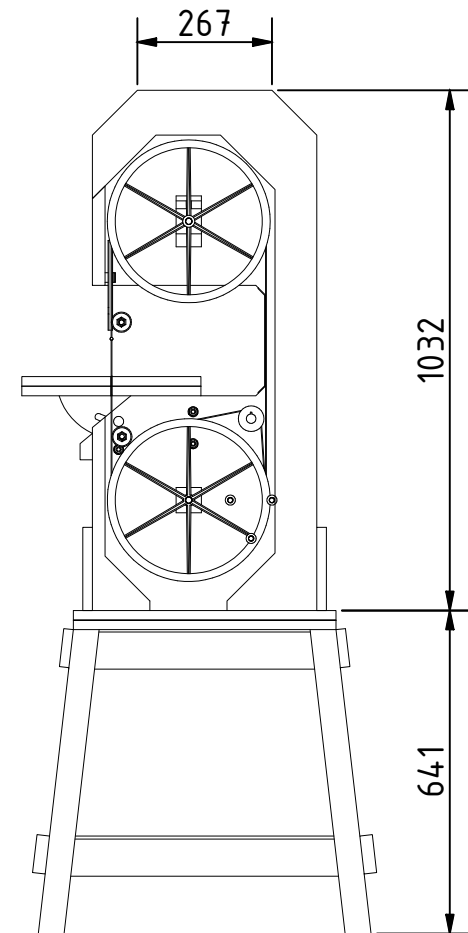
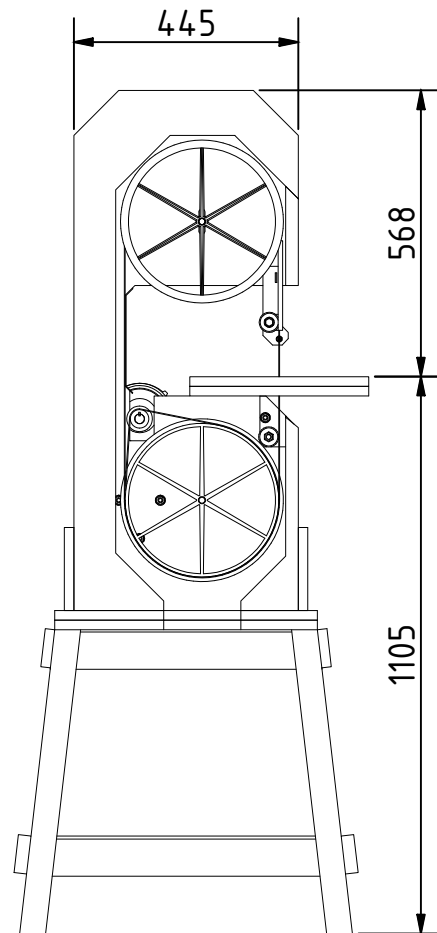
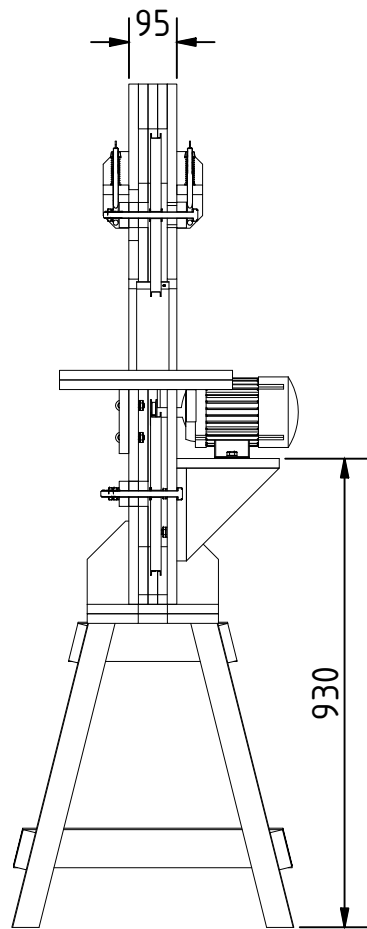

Note: All units in mm.

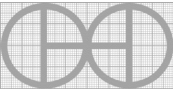
PROJECT	CREATED BY	APPROVED BY	DATE	VERSION
Bandsaw wheel - Dia 12 inch	E. Araujo	A. Morillo	13/09/2021	1.0
PART NAME	FILE NAME			POS
3D views	jah_bsw_bandsaw_wheel_-_dia_12_inch.dwg			1.0
PUBLISHED BY	DOC. TYPE	MATERIAL	QUANTITY	
 OPEN HARDWARE OBSERVATORY Free Blueprints for Sustainable Development	Assembly		1	
	LICENCE	SCALE	SHEET	
OHO e.V.	CC-BY-SA 4.0	Scale	3/55	

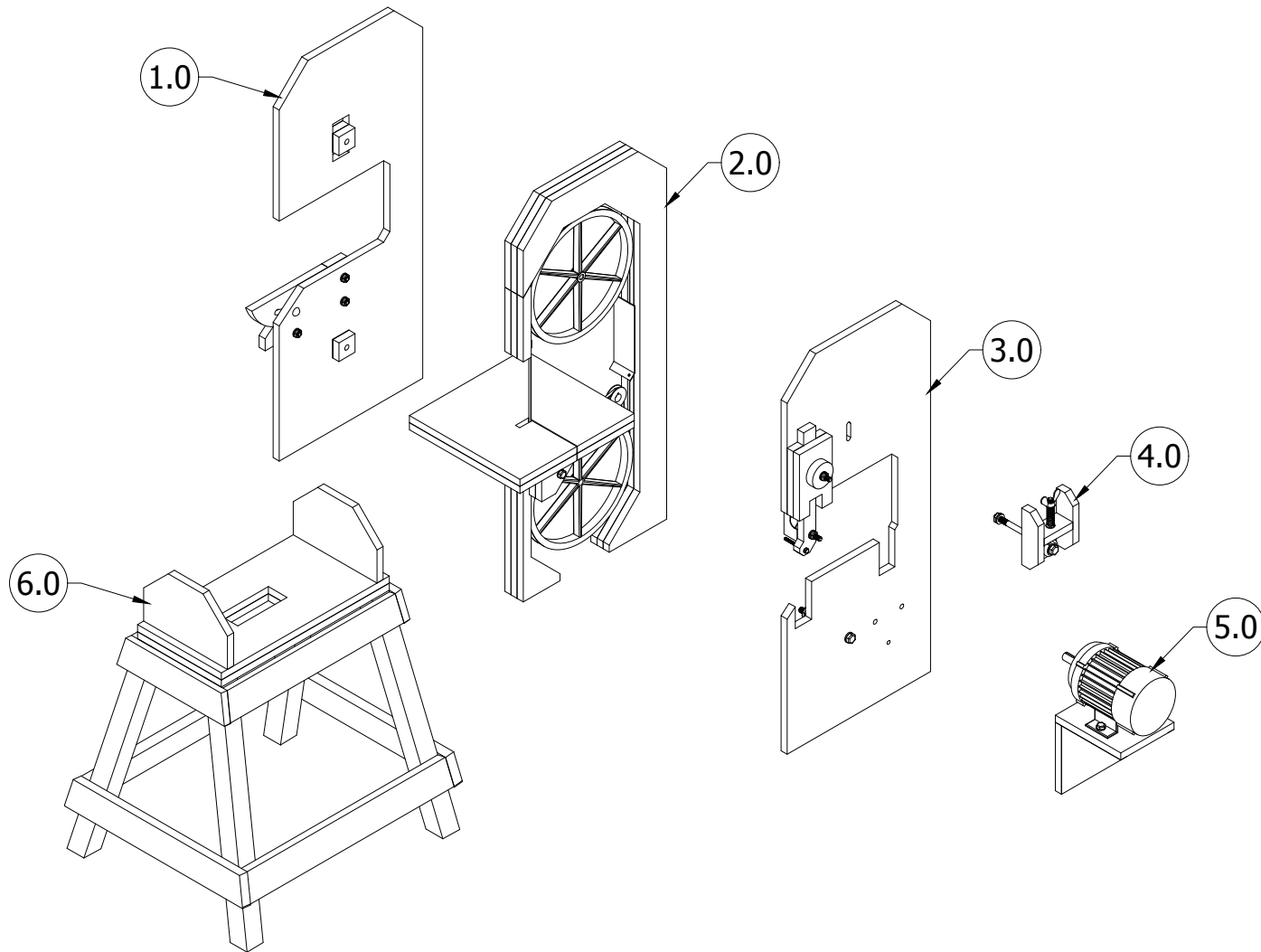

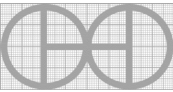
PROJECT	CREATED BY	APPROVED BY	DATE	VERSION
Bandsaw wheel - Dia 12 inch	E. Araujo	A. Morillo	13/09/2021	1.0
PART NAME	FILE NAME			POS
Exploded 3D view	jah_bsw_bandsaw_wheel_-_dia_12_inch.dwg			A2
PUBLISHED BY	DOC. TYPE	MATERIAL	QUANTITY	
 OPEN HARDWARE OBSERVATORY Free Blueprints for Sustainable Development OHO e.V.	Assembly		1	
	LICENCE	SCALE	SHEET	
	CC-BY-SA 4.0	1:15	4/55	

POS	QTY	PART NAME	FILE NAME	PART TYPE	SPECIFICATIONS	SHEET
A1		3d views	jah_bsw_bandsaw_wheel_-_dia_0.1.dwg			1
A1		3d views	jah_bsw_bandsaw_wheel_-_dia_0.1.dwg			2
A1		3d views	jah_bsw_bandsaw_wheel_-_dia_0.1.dwg			3
A2		Exploded 3d view	jah_bsw_bandsaw_wheel_-_dia_0.1.dwg			4
B1		Parts list	jah_bsw_bandsaw_wheel_-_dia_0.1.xlsx			5
B2		Parts list	jah_bsw_bandsaw_wheel_-_dia_0.1.xlsx			6
B3		Parts list	jah_bsw_bandsaw_wheel_-_dia_0.1.xlsx			7
C1		Technical notes	jah_bsw_bandsaw_wheel_-_dia_0.1.dwg			8
1.0	1	Back Side panel	jah_bsw_bandsaw_wheel_-_dia_0.1.dwg			9
1.1	1	Outer panel 1	jah_bsw_bandsaw_wheel_-_dia_0.1.dwg	Production	Plywood 1032 x 445 x 19 mm	10
1.2	2	Panel 1	jah_bsw_bandsaw_wheel_-_dia_0.1.dwg	Production	Plywood 356 x 178 x 19 mm	11
1.3	2	Panel 2	jah_bsw_bandsaw_wheel_-_dia_0.1.dwg	Production	Plywood 356 x 178 x 19 mm	12
1.4	4	Panel 3	jah_bsw_bandsaw_wheel_-_dia_0.1.dwg	Production	Plywood 50 x 50 x 19 mm	13
1.5	2	Panel 4	jah_bsw_bandsaw_wheel_-_dia_0.1.dwg	Production	Plywood 50 x 75 x 19 mm	14
1.6	1	Panel 5	jah_bsw_bandsaw_wheel_-_dia_0.1.dwg	Production	Plywood 51 x 89 x 19 mm	15
1.7	2	Panel 6	jah_bsw_bandsaw_wheel_-_dia_0.1.dwg	Production	Plywood 152 x 51 x 19 mm	16
1.8	1	Eyebolt 1	jah_bsw_bandsaw_wheel_-_dia_0.1.dwg	Production	Steel bar A36 x 175 x 10 mm	17
1.9	2	Eyebolt nut		Standard	M10 nut DIN 315	
1.10	4	Bolt 1		Standard	M10 x 40 mm DIN 603	
1.11	3	Nut 1		Standard	M10 DIN 934	
1.12	5	Washer 1		Standard	M10 DIN 125	
1.13	1	Spring		Standard	Helical Spring 40 x 10 mm	
1.14	1	Washer 2		Standard	M12 DIN 125	
1.15	1	Nut 2		Standard	M12 DIN 934	
1.16	1	Bolt 2		Standard	M10 x 60 mm DIN 603	
2.0	1	Inner side panel	jah_bsw_bandsaw_wheel_-_dia_0.1.dwg			18
2.1	3	Inner panel 1	jah_bsw_bandsaw_wheel_-_dia_0.1.dwg	Production	Plywood 1032 x 445 x 19 mm	19
2.2	3	Inner panel 2	jah_bsw_bandsaw_wheel_-_dia_0.1.dwg	Production	Plywood 384 x 114 x 19 mm	20
2.3	3	Inner panel 3	jah_bsw_bandsaw_wheel_-_dia_0.1.dwg	Production	Plywood 197 x 25 x 19 mm	21
2.4	1	Rear blade guard	jah_bsw_bandsaw_wheel_-_dia_0.1.dwg	Production	Sheet metal Steel C45 220 x 64 x 1,5 mm	22
2.5	2	Panel 4	jah_bsw_bandsaw_wheel_-_dia_0.1.dwg	Production	Plywood 343 x 355 x 19 mm	23

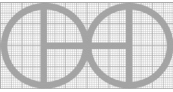
PROJECT		CREATED BY	APPROVED BY	DATE	VERSION
Bandsaw wheel - Dia 12 inch		E. Araujo	A. Morillo	13/09/2021	1.0
PART NAME		FILE NAME			POS
Parts list		jah_bsw_bandsaw_wheel_-_dia_12_inch.xlsx			B1
PUBLISHED BY		DOC. TYPE	MATERIAL		QUANTITY
 OPEN HARDWARE OBSERVATORY Free Blueprints for Sustainable Development		Parts list			
		LICENCE		SCALE	SHEET
OHO e.V.		CC-BY-SA 4.0			5/55

POS	QTY	PART NAME	FILE NAME	PART TYPE	SPECIFICATIONS	SHEET
2.6	1	Panel 5	jah_bsw_bandsaw_wheel_-_dia_0.1.dwg	Production	Plywood 191 x 128 x 19 mm	24
2.7	1	Panel 6	jah_bsw_bandsaw_wheel_-_dia_0.1.dwg	Production	Plywood 89 x 25 x 19mm	25
2.8	1	Panel 7	jah_bsw_bandsaw_wheel_-_dia_0.1.dwg	Production	Plywood 64 x 64 x 19mm	26
2.9	1	Blade	jah_bsw_bandsaw_wheel_-_dia_0.1.dwg	Production	Sheet metal C45 38 x 19 x 1,5 mm	27
2.10	1	Wood block	jah_bsw_bandsaw_wheel_-_dia_0.1.dwg	Production	Plywood 25 x 19 x19 mm	28
2.11	2	Pulley 1		Buy	DIN 2211 x 315mm	
2.12	1	Bolt 1		Standard	M10 X 120 DIN 933	
2.13	1	Bolt 2		Standard	M10 x40 DIN 933	
2.14	5	Nut		Standard	M10 DIN 934	
2.15	4	Washer		Standard	M10 DIN 125	
2.16	1	Pulley 2		Buy	DIN 2211 x 50mm	
2.17	1	Rubber washer	jah_bsw_bandsaw_wheel_-_dia_0.1.dwg	Production	Rubber 13 mm x 2,5 mm	29
2.18	1	Band saw blade		Buy	Bandsaw Blade 2074mm x 6mm 14 tpi carbon	
2.19	1	Scroll		Buy	Steel A36 40 mm	
2.20	1	Leash		Buy	Leash rubber 1030mm x 10mm	
3.0		Front side panel	jah_bsw_bandsaw_wheel_-_dia_0.1.dwg			30
3.1	1	Front panel	jah_bsw_bandsaw_wheel_-_dia_0.1.dwg	Production	Plywood 1032 x 445 x 19 mm	31
3.2	1	Panel 1	jah_bsw_bandsaw_wheel_-_dia_0.1.dwg	Production	Plywood 178 x 32 x 19 mm	32
3.3	1	Panel 2	jah_bsw_bandsaw_wheel_-_dia_0.1.dwg	Production	Plywood 330 x 50 x 19 mm	33
3.4	1	Panel 3	jah_bsw_bandsaw_wheel_-_dia_0.1.dwg	Production	Plywood 178 x 32 x 19 mm	34
3.5	1	Panel 4	jah_bsw_bandsaw_wheel_-_dia_0.1.dwg	Production	Plywood 178 x 102 x 19 mm	35
3.6	1	Wood hand wheel	jah_bsw_bandsaw_wheel_-_dia_0.1.dwg	Production	Plywood 64mm	36
3.7	1	Threaded bar		Buy	Steel bar A36 M10 x 60 mm	
3.8	4	Nut 1		Standard	M10 DIN 934	
3.9	4	Washer		Standard	M10 DIN 125	
3.10	1	Bolt 1	jah_bsw_bandsaw_wheel_-_dia_0.1.dwg	Production	M8 x 70mm DIN 933	37
3.11	2	Washer		Standard	M8 DIN 125	
3.12	1	Bolt 2		Standard	M12 x 140mm DIN 933	
3.13	1	Washer		Standard	M12 DIN 125	
3.14	2	Nut 2		Standard	M12 DIN 934	
3.15	1	Scroll		Buy	Steel A36 40 mm	
3.16	1	Front blade guard	jah_bsw_bandsaw_wheel_-_dia_0.1.dwg	Production	Sheet metal C45 178 x 79,45 x 1,5 mm	38

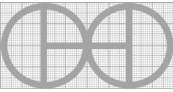
PROJECT		CREATED BY		APPROVED BY		DATE		VERSION	
Bandsaw wheel - Dia 12 inch		E. Araujo		A. Morillo		13/09/2021		1.0	
PART NAME			FILE NAME				POS		
Parts list			jah_bsw_bandsaw_wheel_-_dia_12_inch.xlsx				B2		
PUBLISHED BY				DOC. TYPE		MATERIAL		QUANTITY	
 OPEN HARDWARE OBSERVATORY Free Blueprints for Sustainable Development				Parts list					
				LICENCE		SCALE		SHEET	
OHO e.V.				CC-BY-SA 4.0				6/55	

POS	QTY	PART NAME	FILE NAME	PART TYPE	SPECIFICATIONS	SHEET
3.17	1	Bolt 3		Standard	M10 x 80 mm DIN 933	
3.18	1	Nut 3		Standard	M8 DIN 934	
4.0		Pulley support	jah_bsw_bandsaw_wheel_-_dia_0.1.dwg			39
4.1	1	Eyebolt nut		Standard	M10 nut DIN 315	
4.2	2	Washer 1		Standard	M10 DIN 125	
4.3	1	Spring		Standard	Helical Spring 40 x 10 mm	
4.4	1	Panel 1	jah_bsw_bandsaw_wheel_-_dia_0.1.dwg	Production	Plywood 152 x 51 x 19 mm	40
4.5	1	Panel 2	jah_bsw_bandsaw_wheel_-_dia_0.1.dwg	Production	Plywood 89 x 51 x 19 mm	41
4.6	1	Nut		Standard	M12 DIN 934	
4.7	2	Washer 2		Standard	M12 DIN 125	
4.8	1	Panel 3	jah_bsw_bandsaw_wheel_-_dia_0.1.dwg	Production	Plywood 50 x 50 x 19 mm	42
4.9	1	Eyebolt 2	jah_bsw_bandsaw_wheel_-_dia_0.1.dwg	Production	Steel bar A36 x 175 x 10 mm	43
4.10	?	Bolt		Standard	M12 x 140 DIN 931	
5.0		Motor support	jah_bsw_bandsaw_wheel_-_dia_0.1.dwg			44
5.1	1	Motor base 1	jah_bsw_bandsaw_wheel_-_dia_0.1.dwg	Production	Plywood 184 x 165 x 19 mm	45
5.2	2	Motor base 2	jah_bsw_bandsaw_wheel_-_dia_0.1.dwg	Production	Plywood 184 x 184x 19 mm	46
5.3	1	Motor base 3	jah_bsw_bandsaw_wheel_-_dia_0.1.dwg	Production	Plywood 203 x 165 x 19 mm	47
5.4	2	Bolt		Standard	M10 x 40 mm DIN 933	
5.5	10	Washer		Standard	M10 DIN 125	
5.6	5	Nut		Standard	M10 DIN 934	
5.7	3	Bolt 2		Standard	M10 X 60 mm DIN 931	
5.8	1	Motor		Buy	Motor 1/6 to 1/3 Hp	
6.0		Saw support	jah_bsw_bandsaw_wheel_-_dia_0.1.dwg			48
6.1	2	Saw base 1	jah_bsw_bandsaw_wheel_-_dia_0.1.dwg	Production	Plywood 260 x165 x 19 mm	49
6.2	2	Saw Base 2	jah_bsw_bandsaw_wheel_-_dia_0.1.dwg	Production	Plywood 521 x 260 x 19 mm	50
6.3	2	Strips 1	jah_bsw_bandsaw_wheel_-_dia_0.1.dwg	Production	Plywood 334 x 76 x 25 mm	51
6.4	2	Strips 2	jah_bsw_bandsaw_wheel_-_dia_0.1.dwg	Production	Plywood 540 x 76 x 25 mm	52
6.5	2	Strips 3	jah_bsw_bandsaw_wheel_-_dia_0.1.dwg	Production	Plywood 552 x 76 x 25 mm	53
6.6	2	Strips 4	jah_bsw_bandsaw_wheel_-_dia_0.1.dwg	Production	Plywood 632 x 76 x 25 mm	54
6.7	4	Legs	jah_bsw_bandsaw_wheel_-_dia_0.1.dwg	Production	Plywood 621.50 x 52 x 52 mm	55

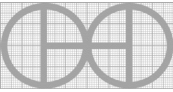
PROJECT		CREATED BY	APPROVED BY	DATE	VERSION
Bandsaw wheel - Dia 12 inch		E. Araujo	A. Morillo	13/09/2021	1.0
PART NAME		FILE NAME			POS
Parts list		jah_bsw_bandsaw_wheel_-_dia_12_inch.xlsx			B3
PUBLISHED BY		DOC. TYPE	MATERIAL		QUANTITY
 OPEN HARDWARE OBSERVATORY Free Blueprints for Sustainable Development		Parts list			
		LICENCE		SCALE	SHEET
OHO e.V.		CC-BY-SA 4.0			7/55

TECHNICAL NOTES

NOTES	CONTENT
GENERAL NOTES	
Metal structure treatment	Iron structures should be painted to prevent rust and improve equipment life. - Remove loose rust with a wire brush, sandpaper or chemical rust remover. - If applicable, sand areas where paint is chipping until surface is smooth. - Remove dust or oil with a degreaser or denatured alcohol. - Prime surface to protect against rust and corrosion
Wood treatment	- The wood must be treated with pesticides and kiln-dried to ensure adequate humidity. - Wood sealer should be applied for later use.

PROJECT	CREATED BY	APPROVED BY	DATE	VERSION
Bandsaw wheel - Dia 12 inch	E. Araujo	A. Morillo	13/09/2021	1.0
PART NAME	FILE NAME			POS
Technical notes	jah_bsw_bandsaw_wheel_-_dia_12_inch.dwg			C1
PUBLISHED BY		DOC. TYPE	MATERIAL	QUANTITY
 OPEN HARDWARE OBSERVATORY Free Blueprints for Sustainable Development OHO e.V.		Technical notes		
		LICENCE	SCALE	SHEET
		CC-BY-SA 4.0		8/55

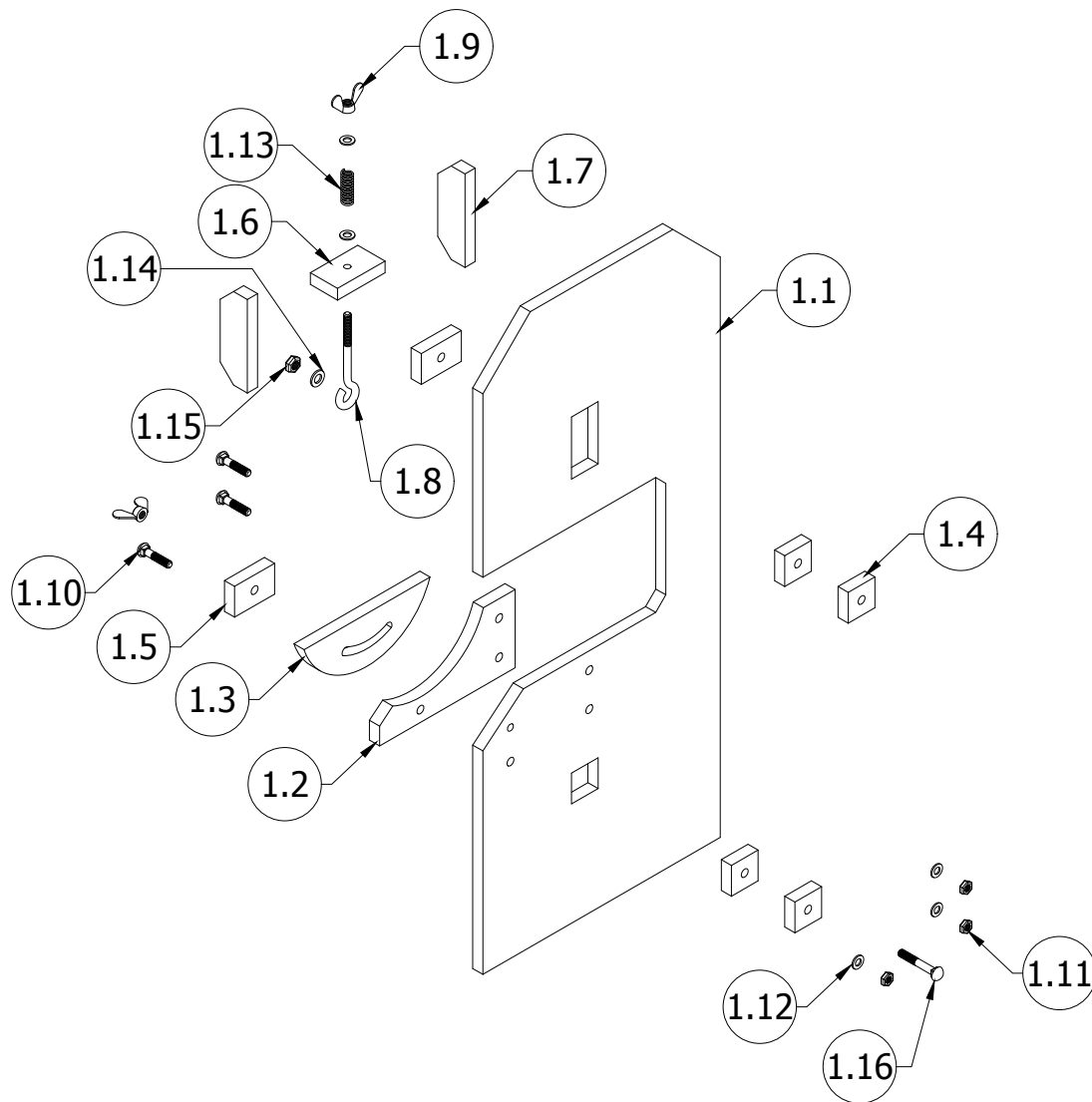

Note: All units in mm.

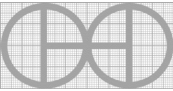
PROJECT	CREATED BY	APPROVED BY	DATE	VERSION
Bandsaw wheel - Dia 12 inch	E. Araujo	A. Morillo	13/09/2021	1.0
PART NAME	FILE NAME			POS
Back side panel	jah_bsw_bandsaw_wheel_-_dia_12_inch.dwg			1.0
PUBLISHED BY	DOC. TYPE	MATERIAL	QUANTITY	
 OPEN HARDWARE OBSERVATORY Free Blueprints for Sustainable Development OHO e.V.	Assembly		1	
	LICENCE	SCALE	SHEET	
	CC-BY-SA 4.0	1:10	9/55	

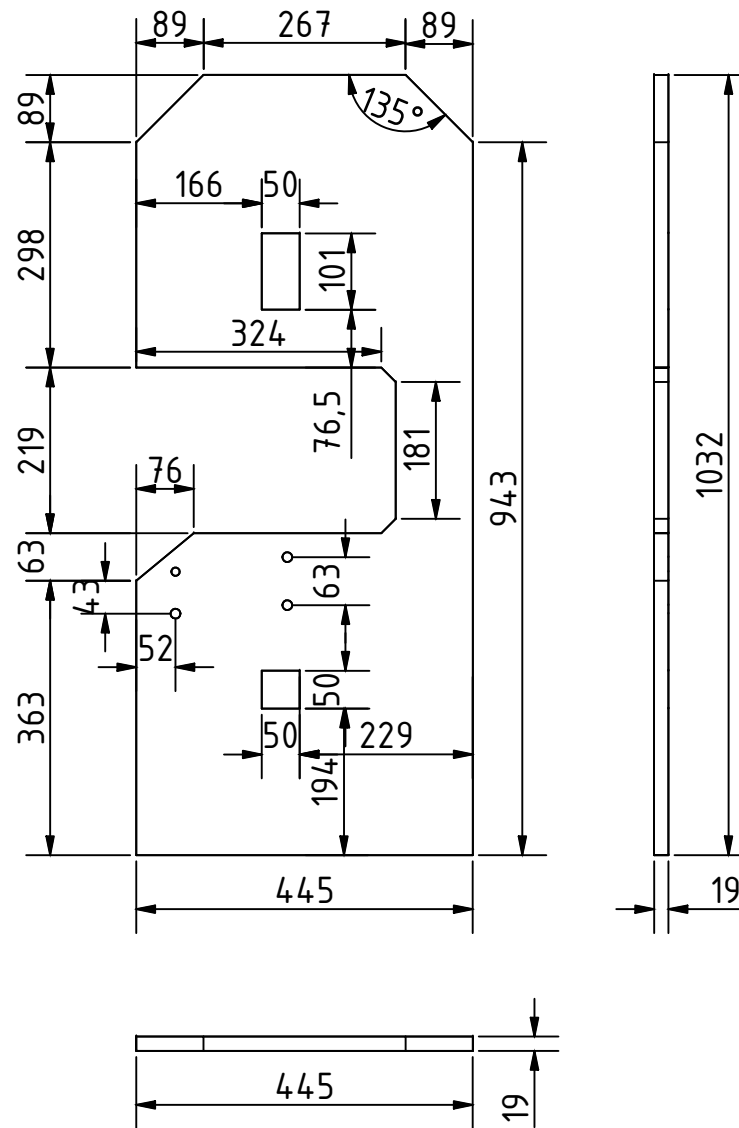
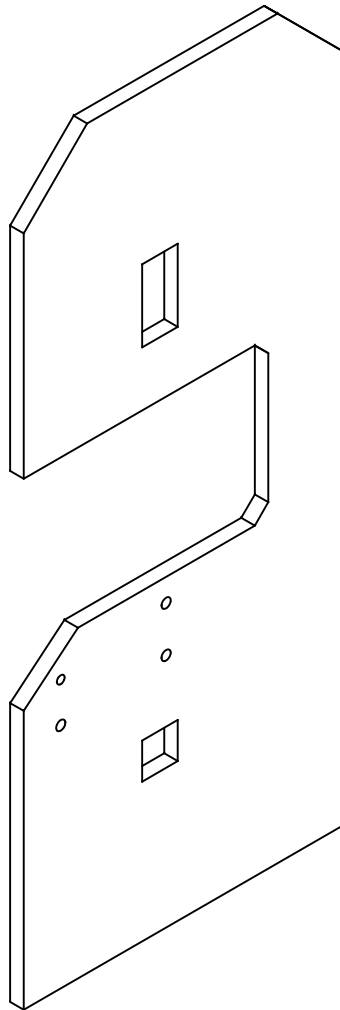

Note: All units in mm.

PROJECT	CREATED BY	APPROVED BY	DATE	VERSION
Bandsaw wheel - Dia 12 inch	E. Araujo	A. Morillo	13/09/2021	1.0
PART NAME	FILE NAME			POS
Outer panel 1	jah_bsw_bandsaw_wheel_-_dia_12_inch.dwg			1.1
PUBLISHED BY	DOC. TYPE	MATERIAL	QUANTITY	
 OPEN HARDWARE OBSERVATORY Free Blueprints for Sustainable Development	Part	Plywood	1	
	LICENCE	SCALE	SHEET	
OHO e.V.	CC-BY-SA 4.0	1:10	10/55	

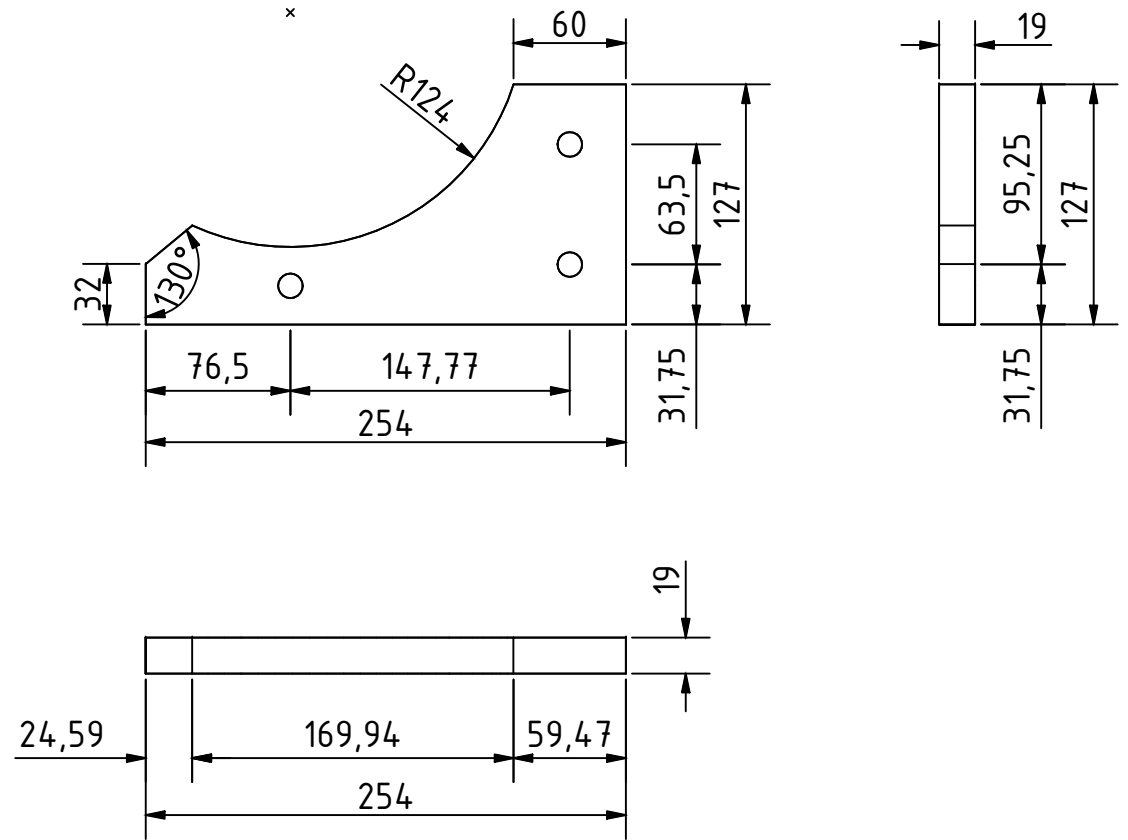
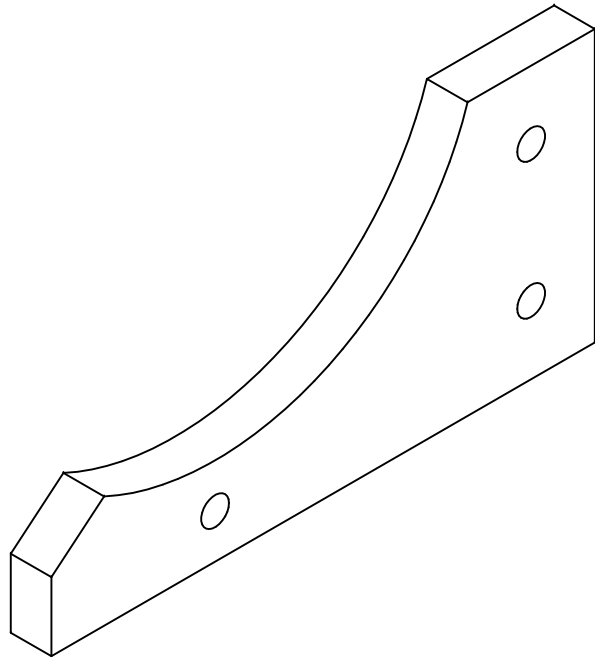

Note: All units in mm.

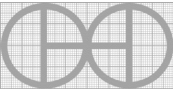
PROJECT	CREATED BY	APPROVED BY	DATE	VERSION
Bandsaw wheel - Dia 12 inch	E. Araujo	A. Morillo	13/09/2021	1.0
PART NAME	FILE NAME			POS
Panel 1	jah_bsw_bandsaw_wheel_-_dia_12_inch.dwg			1.2
PUBLISHED BY	DOC. TYPE	MATERIAL	QUANTITY	
 OPEN HARDWARE OBSERVATORY Free Blueprints for Sustainable Development OHO e.V.	Part	Plywood	1	
	LICENCE	SCALE	SHEET	
	CC-BY-SA 4.0	1:4	11/55	

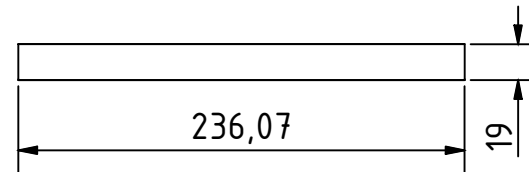
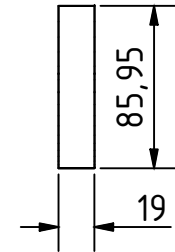
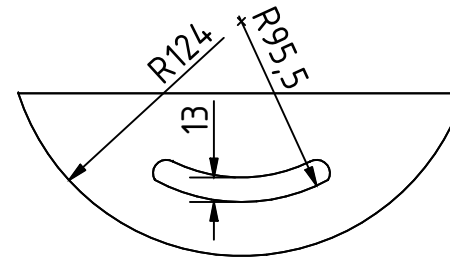
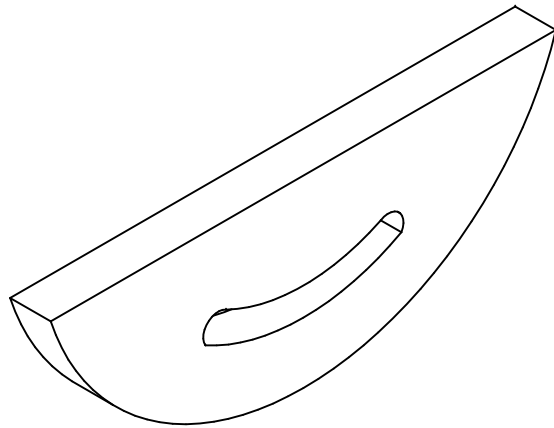

Note: All units in mm.

PROJECT	CREATED BY	APPROVED BY	DATE	VERSION
Bandsaw wheel - Dia 12 inch	E. Araujo	A. Morillo	13/09/2021	1.0
PART NAME	FILE NAME			POS
Panel 2	jah_bsw_bandsaw_wheel_-_dia_12_inch.dwg			1.3
PUBLISHED BY		DOC. TYPE	MATERIAL	QUANTITY
 OPEN HARDWARE OBSERVATORY Free Blueprints for Sustainable Development		Part	Plywood	1
		LICENCE		SHEET
OHO e.V.		CC-BY-SA 4.0	1:4	12/55

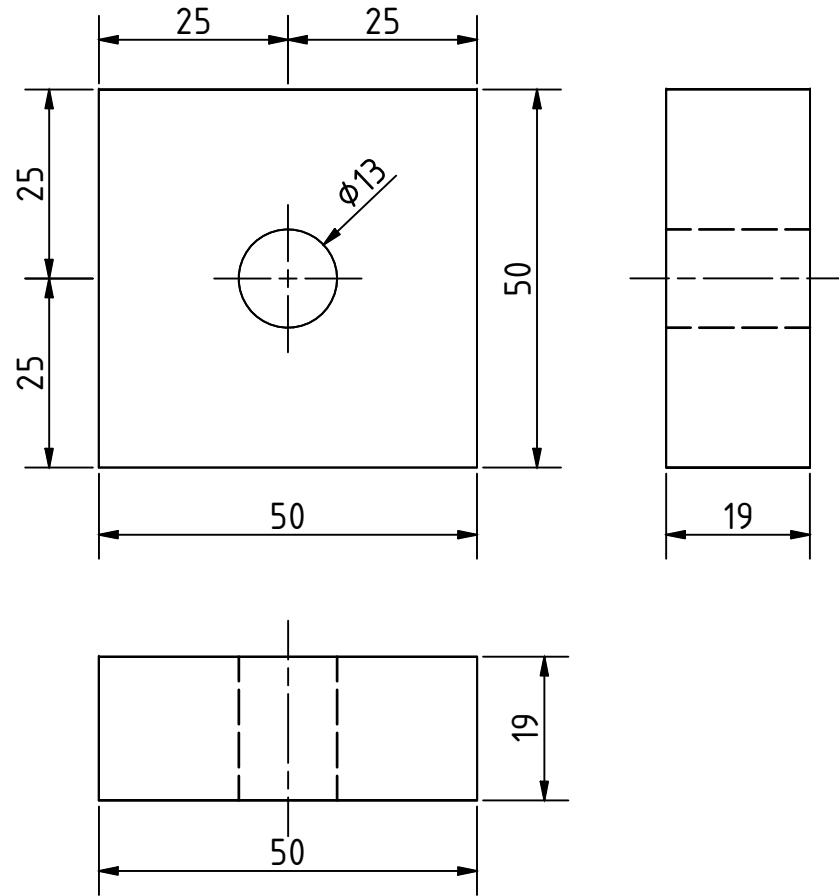
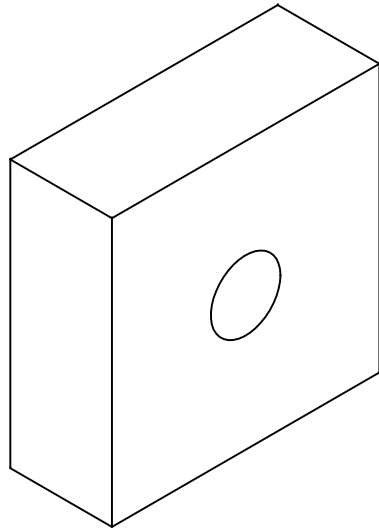

Note: All units in mm.

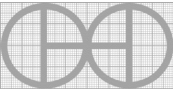
PROJECT	CREATED BY	APPROVED BY	DATE	VERSION
Bandsaw wheel - Dia 12 inch	E. Araujo	A. Morillo	13/09/2021	1.0
PART NAME	FILE NAME			POS
Panel 3	jah_bsw_bandsaw_wheel_-_dia_12_inch.dwg			1.4
PUBLISHED BY	DOC. TYPE	MATERIAL	QUANTITY	
 OPEN HARDWARE OBSERVATORY Free Blueprints for Sustainable Development OHO e.V.	Part	Plywood	4	
	LICENCE	SCALE	SHEET	
	CC-BY-SA 4.0	1:1	13/55	

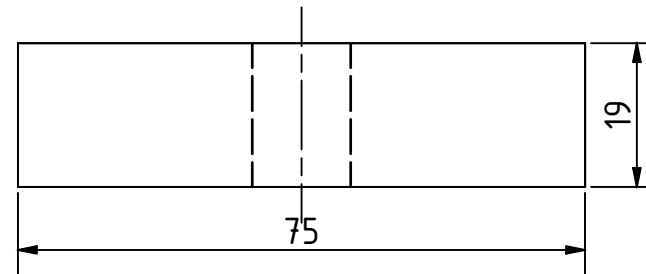
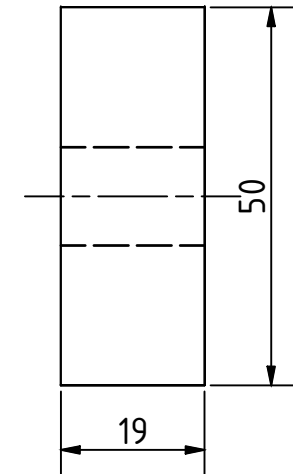
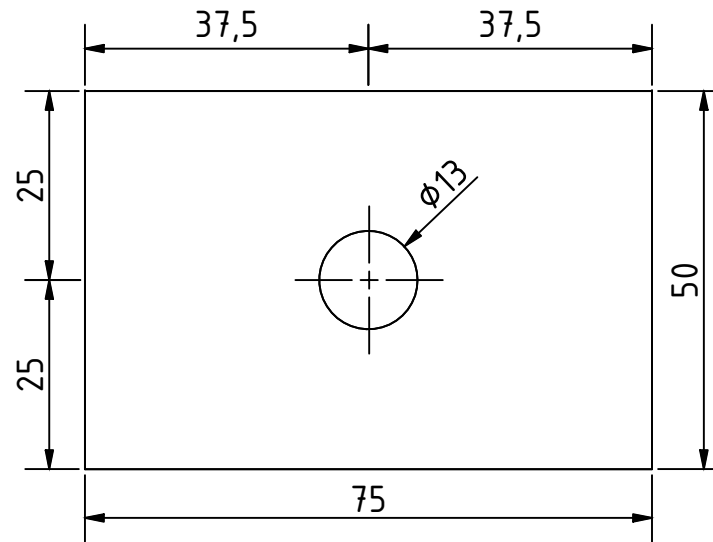
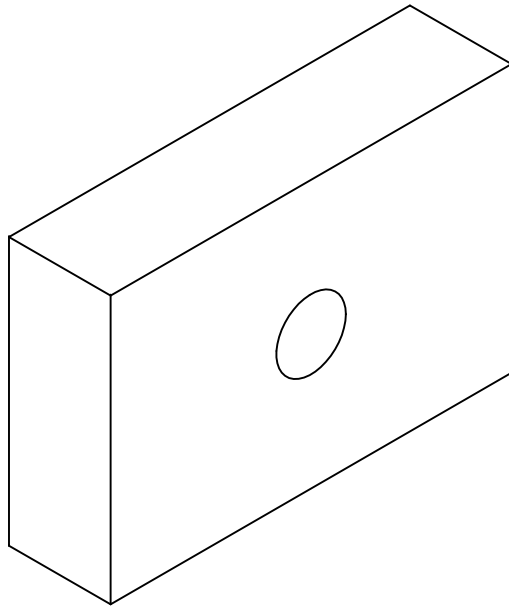

Note: All units in mm.

PROJECT	CREATED BY	APPROVED BY	DATE	VERSION
Bandsaw wheel - Dia 12 inch	E. Araujo	A. Morillo	13/09/2021	1.0
PART NAME	FILE NAME			POS
Panel 4	jah_bsw_bandsaw_wheel_-_dia_12_inch.dwg			1.5
PUBLISHED BY	DOC. TYPE	MATERIAL	QUANTITY	
 OPEN HARDWARE OBSERVATORY Free Blueprints for Sustainable Development	Part	Plywood	2	
	LICENCE	SCALE	SHEET	
OHO e.V.	CC-BY-SA 4.0	1:1	14/55	

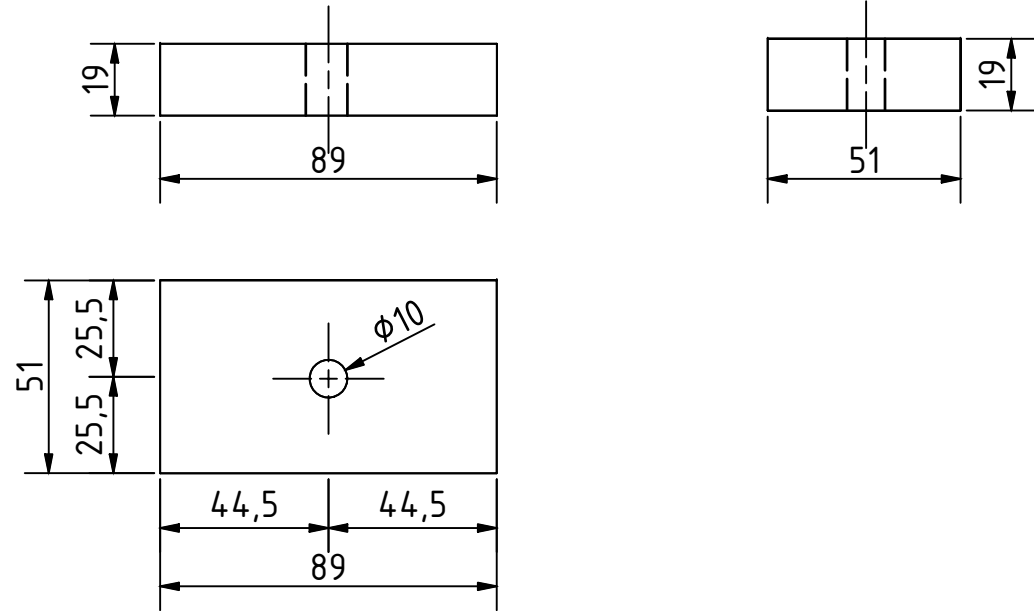
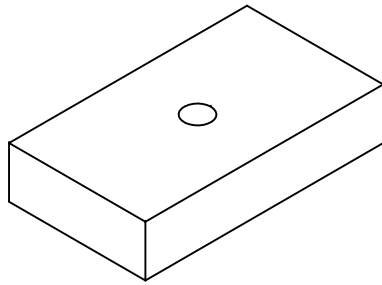

Note: All units in mm.

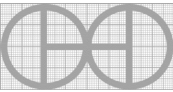
PROJECT	CREATED BY	APPROVED BY	DATE	VERSION
Bandsaw wheel - Dia 12 inch	E. Araujo	A. Morillo	13/09/2021	1.0
PART NAME	FILE NAME			POS
Panel 5	jah_bsw_bandsaw_wheel_-_dia_12_inch.dwg			1.6
PUBLISHED BY	DOC. TYPE	MATERIAL	QUANTITY	
 OPEN HARDWARE OBSERVATORY Free Blueprints for Sustainable Development OHO e.V.	Part	Plywood	1	
	LICENCE	SCALE	SHEET	
	CC-BY-SA 4.0	1:2	15/55	

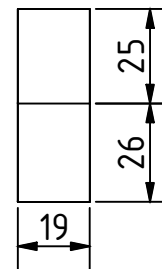
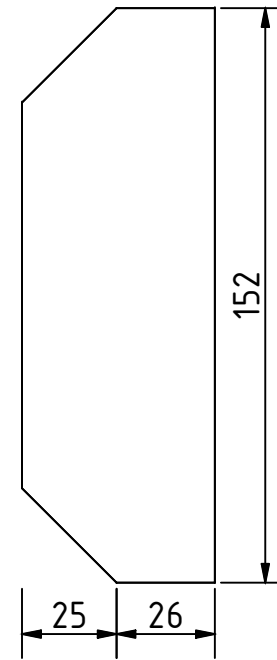
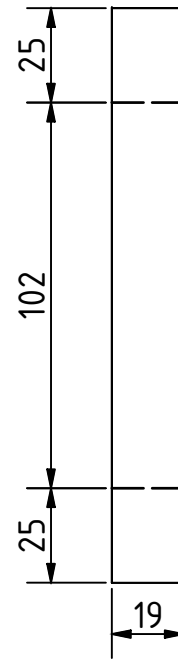
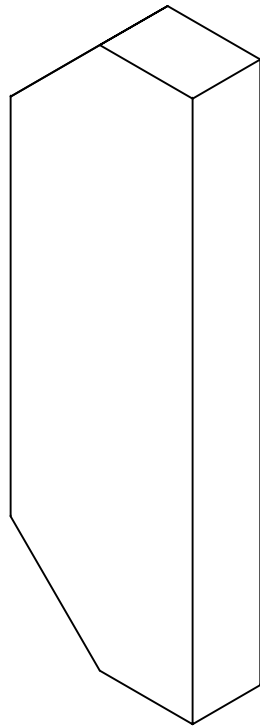

Note: All units in mm.

PROJECT	CREATED BY	APPROVED BY	DATE	VERSION
Bandsaw wheel - Dia 12 inch	E. Araujo	A. Morillo	13/09/2021	1.0
PART NAME	FILE NAME			POS
Panel 6	jah_bsw_bandsaw_wheel_-_dia_12_inch.dwg			1.7
PUBLISHED BY	DOC. TYPE	MATERIAL	QUANTITY	
 OPEN HARDWARE OBSERVATORY Free Blueprints for Sustainable Development OHO e.V.	Part	Plywood	2	
	LICENCE	SCALE	SHEET	
	CC-BY-SA 4.0	1:2	16/55	

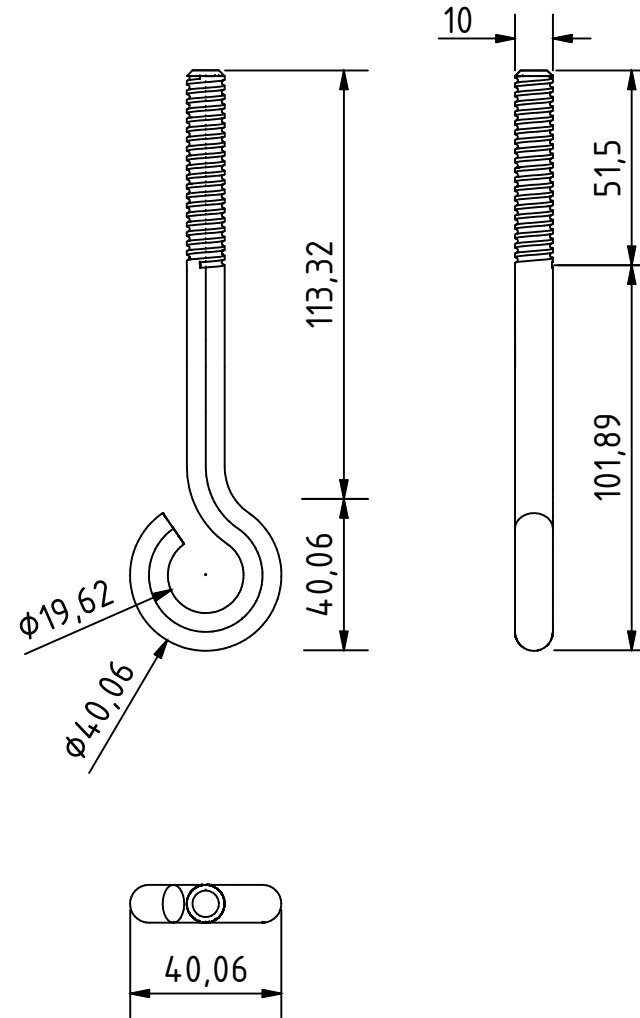
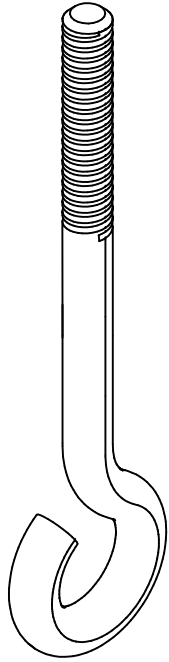

Note: All units in mm.

PROJECT	CREATED BY	APPROVED BY	DATE	VERSION
Bandsaw wheel - Dia 12 inch	E. Araujo	A. Morillo	13/09/2021	1.0
PART NAME	FILE NAME			POS
Eyebolt 1	jah_bsw_bandsaw_wheel_-_dia_12_inch.dwg			1.8
PUBLISHED BY	DOC. TYPE	MATERIAL	QUANTITY	
 OPEN HARDWARE OBSERVATORY Free Blueprints for Sustainable Development OHO e.V.	Part	Steel A36	1	
	LICENCE	SCALE	SHEET	
	CC-BY-SA 4.0	1:2	17/55	

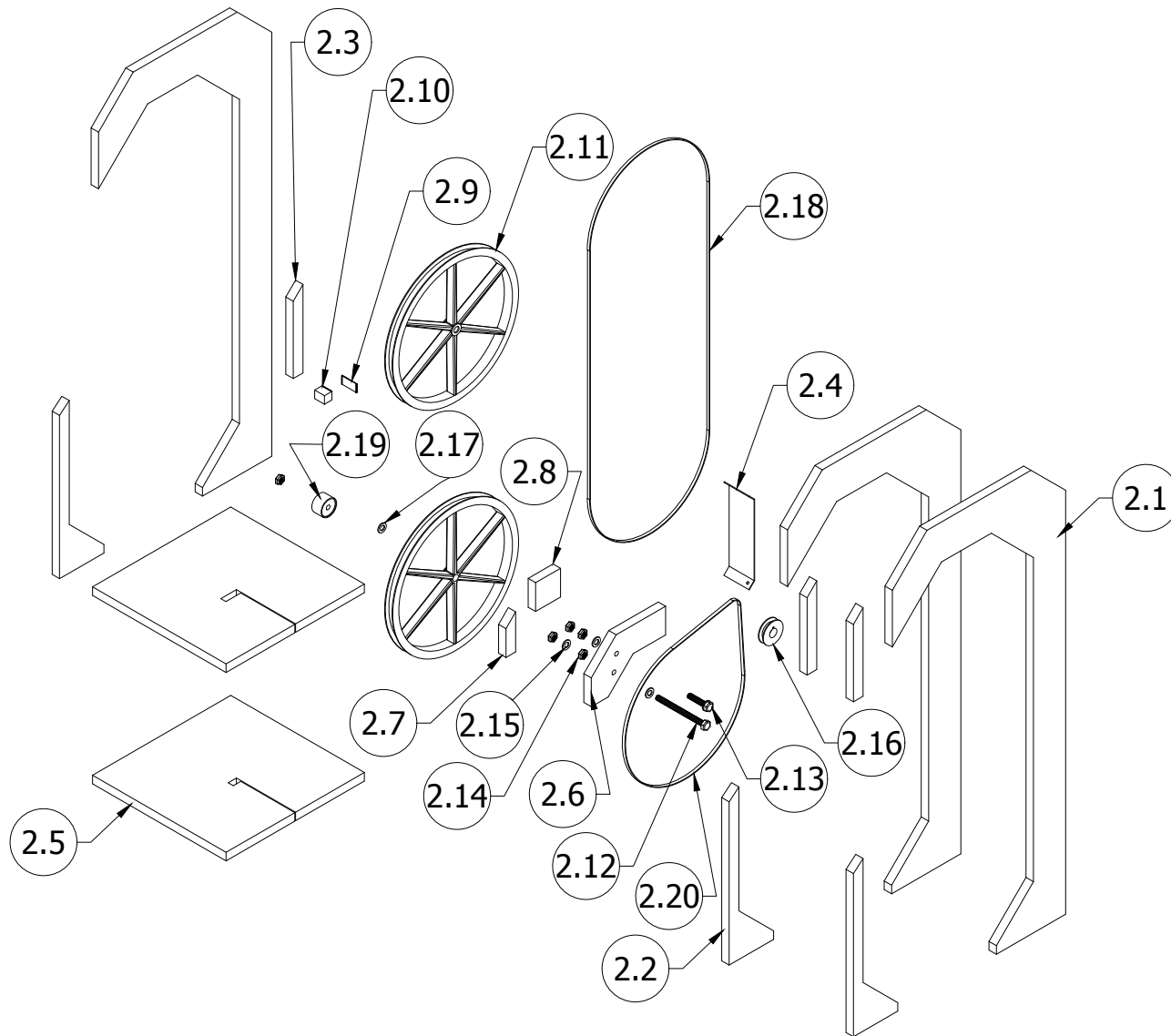

Note: All units in mm.

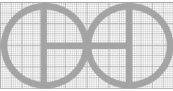
PROJECT	CREATED BY	APPROVED BY	DATE	VERSION
Bandsaw wheel - Dia 12 inch	E. Araujo	A. Morillo	13/09/2021	1.0
PART NAME	FILE NAME			POS
Inner side panel	jah_bsw_bandsaw_wheel_-_dia_12_inch.dwg			2.0
PUBLISHED BY	DOC. TYPE	MATERIAL	QUANTITY	
 OPEN HARDWARE OBSERVATORY Free Blueprints for Sustainable Development OHO e.V.	Assembly		1	
	LICENCE	SCALE	SHEET	
	CC-BY-SA 4.0	1:15	18/55	

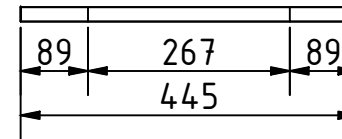
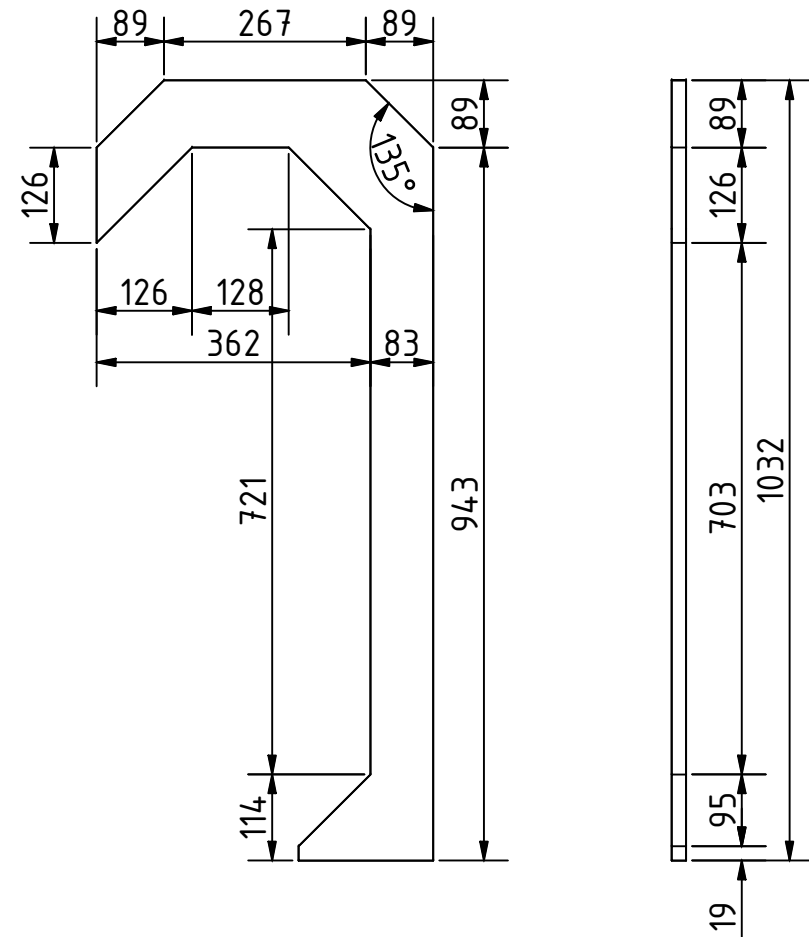
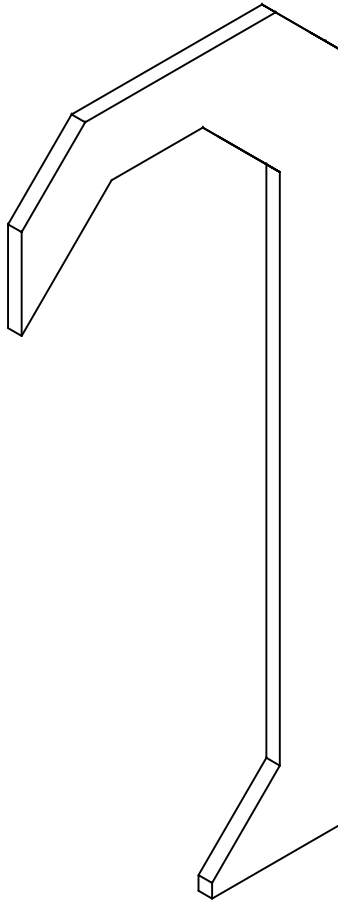

Note: All units in mm.

PROJECT	CREATED BY	APPROVED BY	DATE	VERSION
Bandsaw wheel - Dia 12 inch	E. Araujo	A. Morillo	13/09/2021	1.0
PART NAME	FILE NAME			POS
Inner panel 1	jah_bsw_bandsaw_wheel_-_dia_12_inch.dwg			2.1
PUBLISHED BY	DOC. TYPE	MATERIAL	QUANTITY	
 OPEN HARDWARE OBSERVATORY Free Blueprints for Sustainable Development	Part	Plywood	3	
	LICENCE	SCALE	SHEET	
OHO e.V.	CC-BY-SA 4.0	1:10	19/55	

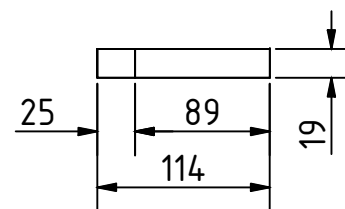
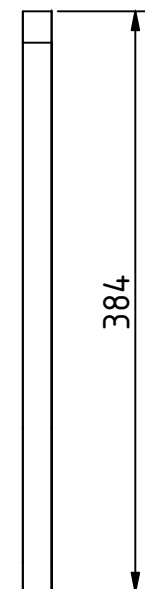
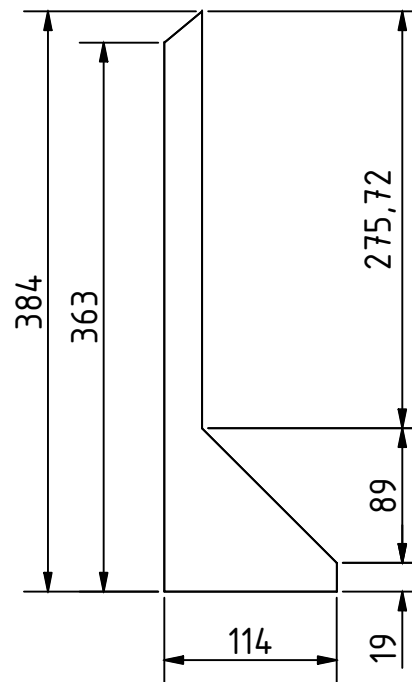
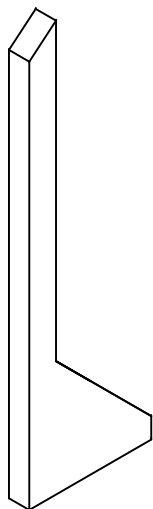

Note: All units in mm.

PROJECT	CREATED BY	APPROVED BY	DATE	VERSION
Bandsaw wheel - Dia 12 inch	E. Araujo	A. Morillo	13/09/2021	1.0
PART NAME	FILE NAME			POS
Inner panel 2	jah_bsw_bandsaw_wheel_-_dia_12_inch.dwg			2.2
PUBLISHED BY	DOC. TYPE	MATERIAL	QUANTITY	
 OPEN HARDWARE OBSERVATORY Free Blueprints for Sustainable Development OHO e.V.	Part	Plywood	3	
	LICENCE	SCALE	SHEET	
	CC-BY-SA 4.0	1:5	20/55	

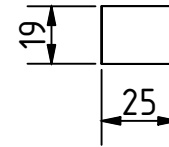
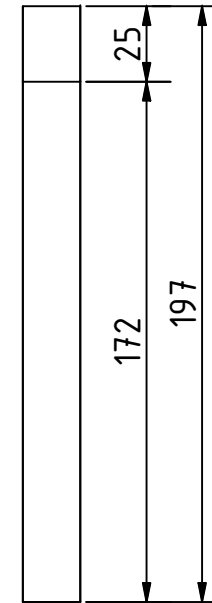
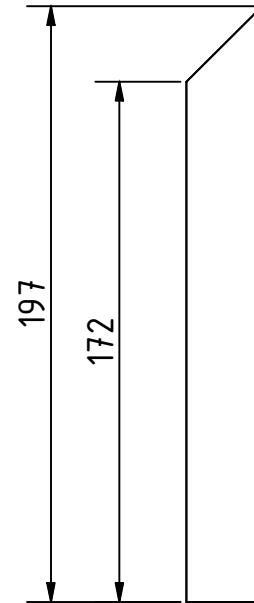
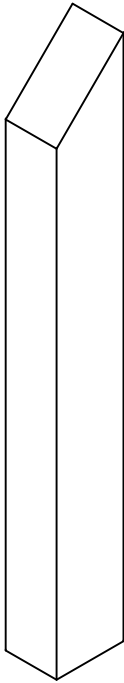

Note: All units in mm.

PROJECT	CREATED BY	APPROVED BY	DATE	VERSION
Bandsaw wheel - Dia 12 inch	E. Araujo	A. Morillo	13/09/2021	1.0
PART NAME	FILE NAME			POS
Inner panel 3	jah_bsw_bandsaw_wheel_-_dia_12_inch.dwg			2.3
PUBLISHED BY	DOC. TYPE	MATERIAL	QUANTITY	
 OPEN HARDWARE OBSERVATORY Free Blueprints for Sustainable Development OHO e.V.	Part	Plywood	3	
	LICENCE	SCALE	SHEET	
	CC-BY-SA 4.0	1:2.5	21/55	

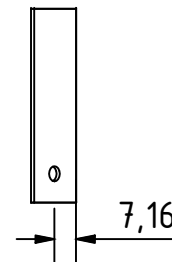
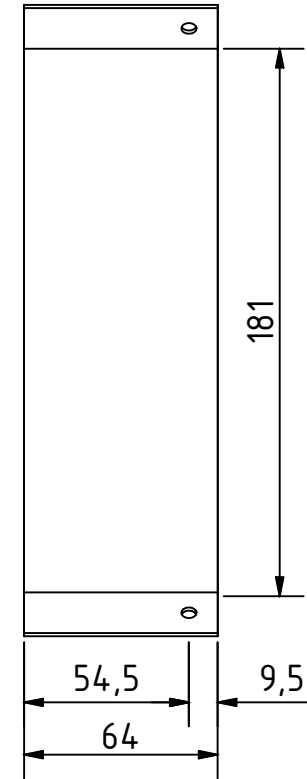
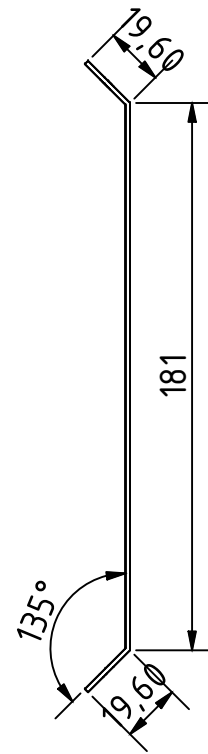
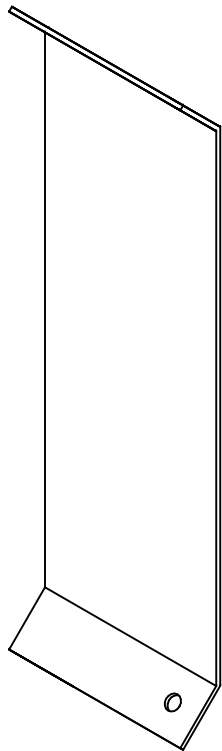

Note: All units in mm.

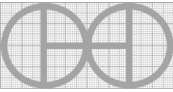
PROJECT	CREATED BY	APPROVED BY	DATE	VERSION
Bandsaw wheel - Dia 12 inch	E. Araujo	A. Morillo	13/09/2021	1.0
PART NAME	FILE NAME			POS
Rear blade guard	jah_bsw_bandsaw_wheel_-_dia_12_inch.dwg			2.4
PUBLISHED BY	DOC. TYPE	MATERIAL	QUANTITY	
 OPEN HARDWARE OBSERVATORY Free Blueprints for Sustainable Development OHO e.V.	Part	Steel C45	1	
	LICENCE	SCALE	SHEET	
	CC-BY-SA 4.0	1:2.5	22/55	

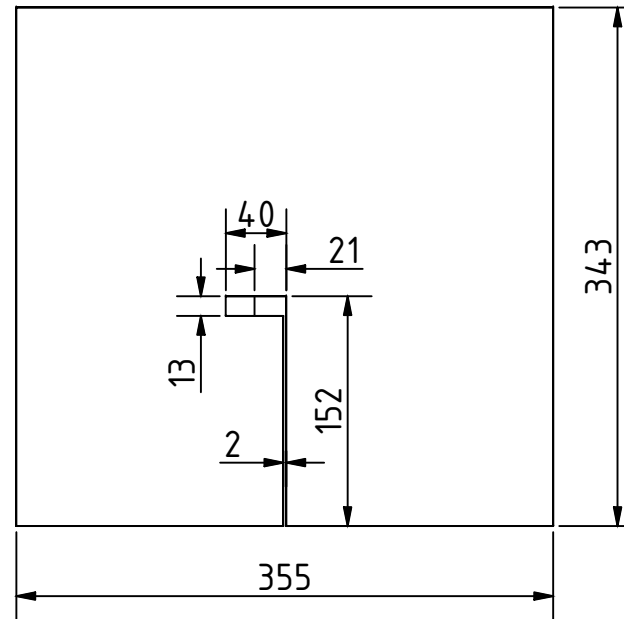
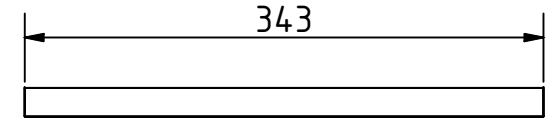
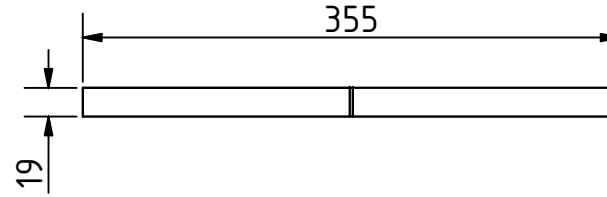
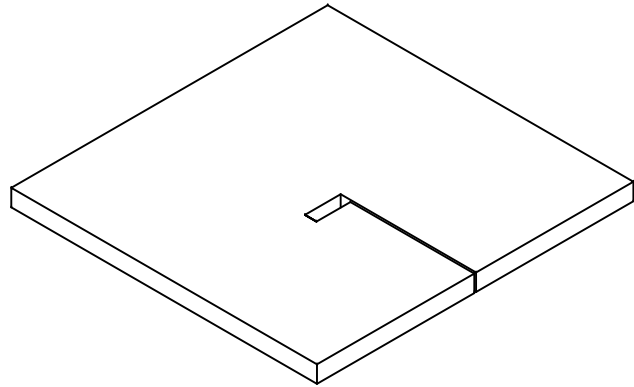

Note: All units in mm.

PROJECT	CREATED BY	APPROVED BY	DATE	VERSION
Bandsaw wheel - Dia 12 inch	E. Araujo	A. Morillo	13/09/2021	1.0
PART NAME	FILE NAME			POS
Panel 4	jah_bsw_bandsaw_wheel_-_dia_12_inch.dwg			2.5
PUBLISHED BY	DOC. TYPE	MATERIAL	QUANTITY	
 OPEN HARDWARE OBSERVATORY Free Blueprints for Sustainable Development OHO e.V.	Part	Plywood	2	
	LICENCE	SCALE	SHEET	
	CC-BY-SA 4.0	1:5	23/55	

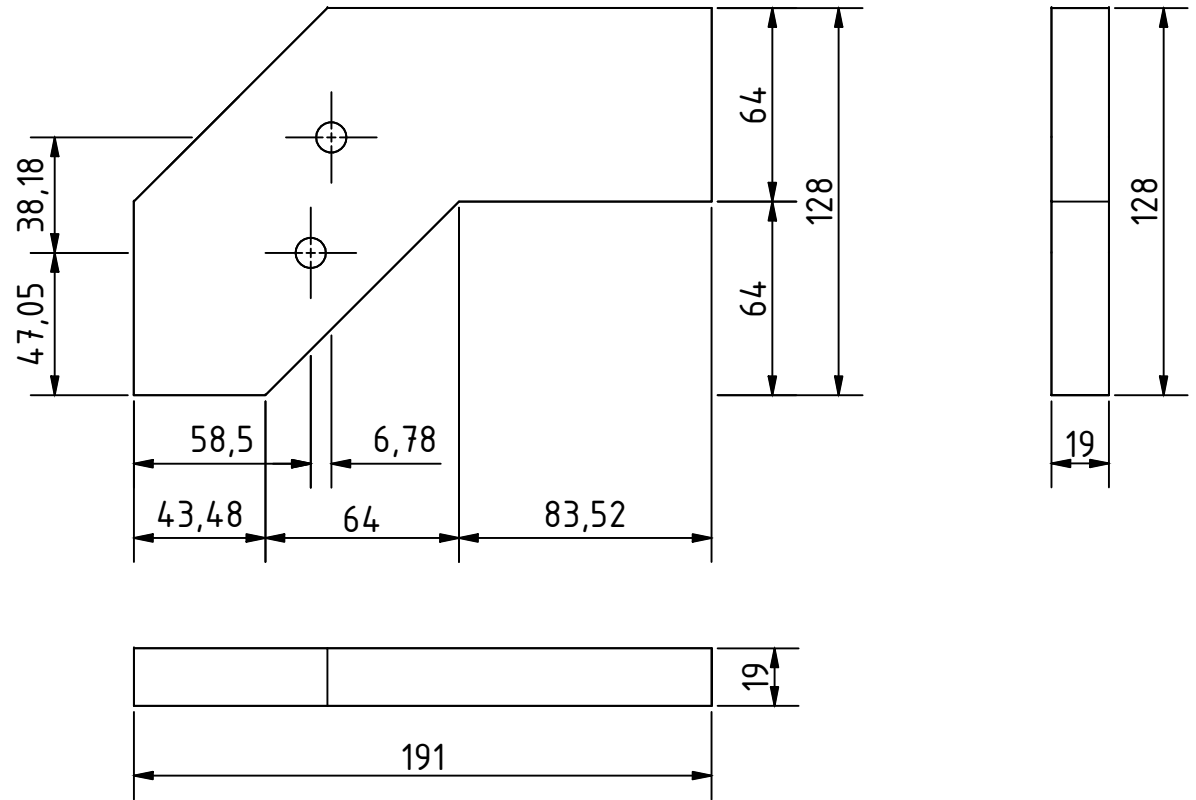
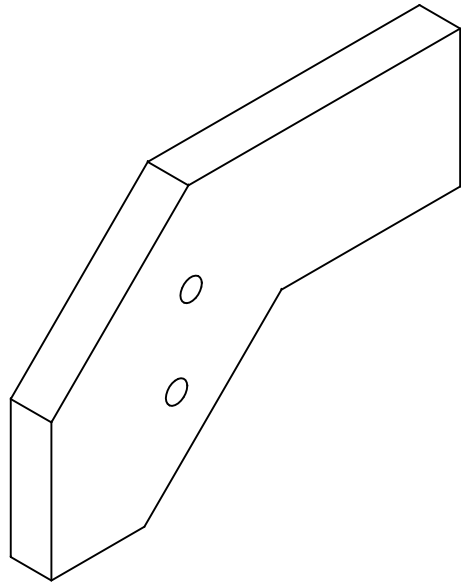

Note: All units in mm.

PROJECT	CREATED BY	APPROVED BY	DATE	VERSION
Bandsaw wheel - Dia 12 inch	E. Araujo	A. Morillo	13/09/2021	1.0
PART NAME	FILE NAME			POS
Panel 5	jah_bsw_bandsaw_wheel_-_dia_12_inch.dwg			2.6
PUBLISHED BY	DOC. TYPE	MATERIAL	QUANTITY	
 OPEN HARDWARE OBSERVATORY Free Blueprints for Sustainable Development	Part	Plywood	1	
	LICENCE	SCALE	SHEET	
OHO e.V.	CC-BY-SA 4.0	1:2.5	24/55	

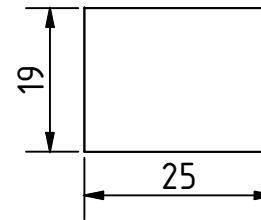
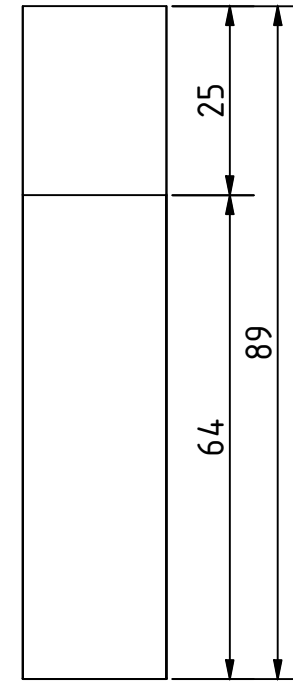
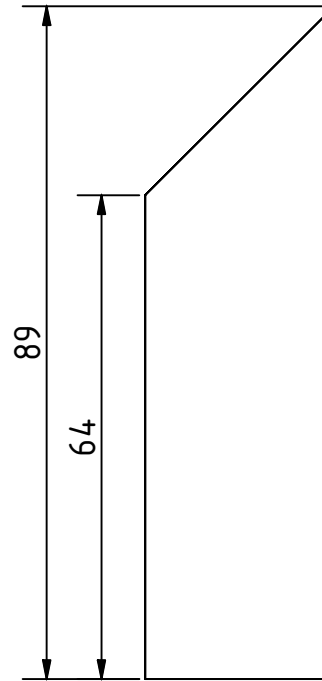
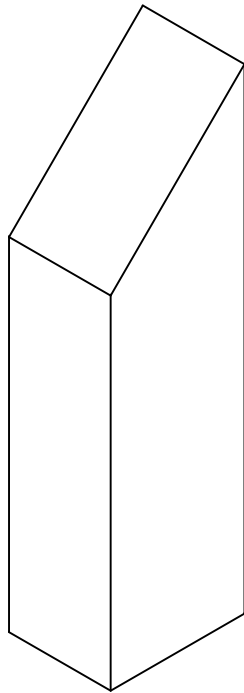

Note: All units in mm.

PROJECT	CREATED BY	APPROVED BY	DATE	VERSION
Bandsaw wheel - Dia 12 inch	E. Araujo	A. Morillo	13/09/2021	1.0
PART NAME	FILE NAME			POS
Panel 6	jah_bsw_bandsaw_wheel_-_dia_12_inch.dwg			2.7
PUBLISHED BY	DOC. TYPE	MATERIAL	QUANTITY	
 OPEN HARDWARE OBSERVATORY Free Blueprints for Sustainable Development OHO e.V.	Part	Plywood	1	
	LICENCE	SCALE	SHEET	
	CC-BY-SA 4.0	1:2.5	25/55	

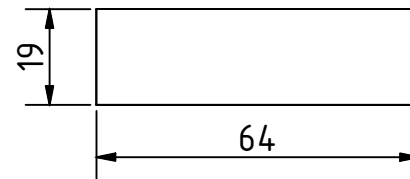
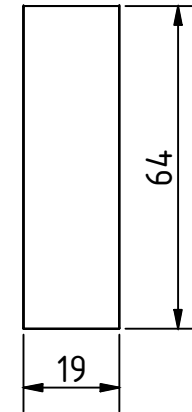
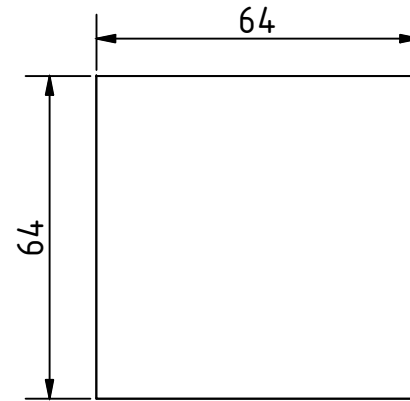
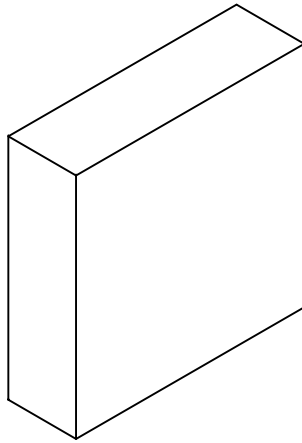

Note: All units in mm.

PROJECT	CREATED BY	APPROVED BY	DATE	VERSION
Bandsaw wheel - Dia 12 inch	E. Araujo	A. Morillo	13/09/2021	1.0
PART NAME	FILE NAME			POS
Panel 7	jah_bsw_bandsaw_wheel_-_dia_12_inch.dwg			2.8
PUBLISHED BY	DOC. TYPE	MATERIAL	QUANTITY	
 OPEN HARDWARE OBSERVATORY Free Blueprints for Sustainable Development OHO e.V.	Part	Plywood	1	
	LICENCE	SCALE	SHEET	
	CC-BY-SA 4.0	1:1.5	26/55	

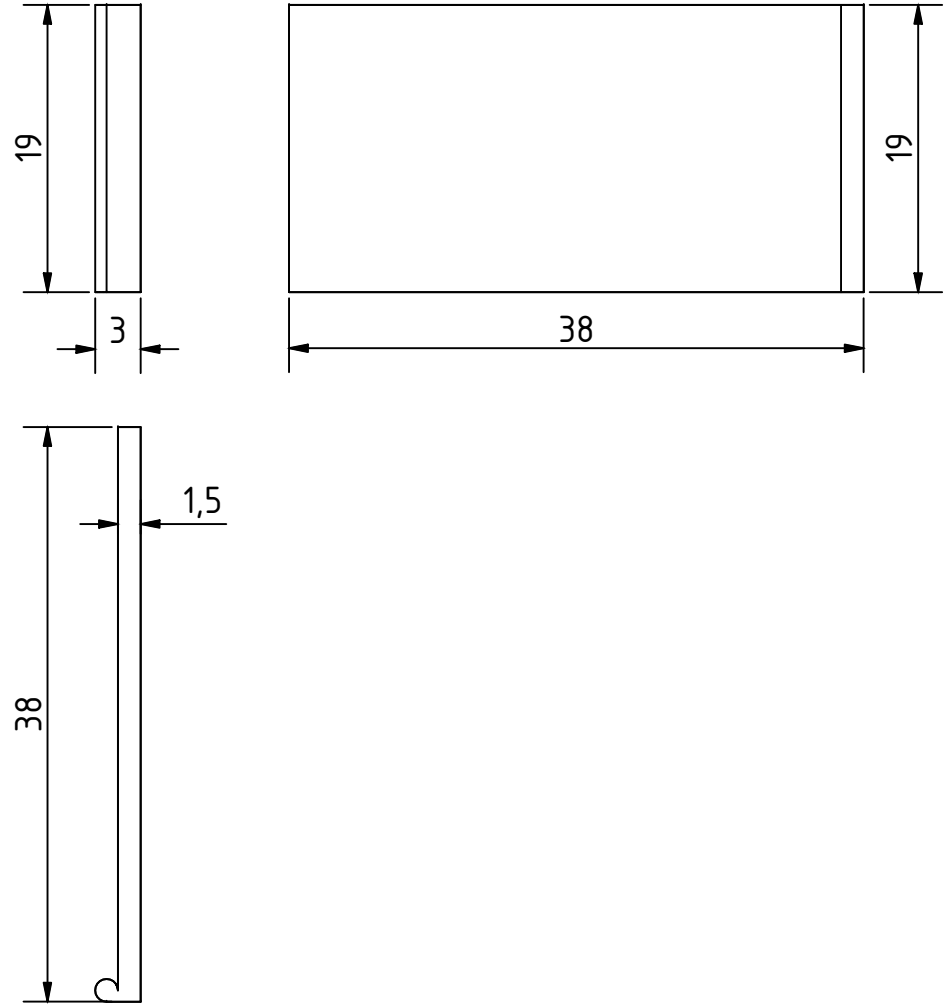
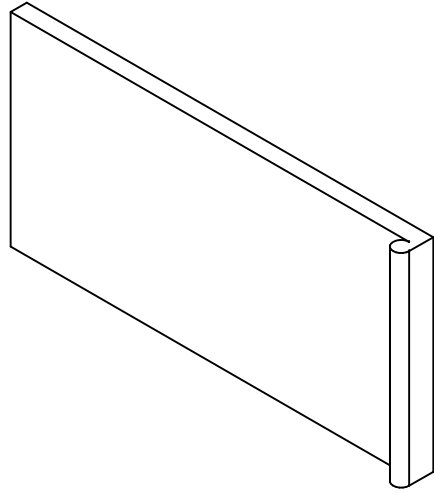

Note: All units in mm.

PROJECT	CREATED BY	APPROVED BY	DATE	VERSION
Bandsaw wheel - Dia 12 inch	E. Araujo	A. Morillo	13/09/2021	1.0
PART NAME	FILE NAME			POS
Blade	jah_bsw_bandsaw_wheel_-_dia_12_inch.dwg			2.9
PUBLISHED BY	DOC. TYPE	MATERIAL	QUANTITY	
 OPEN HARDWARE OBSERVATORY Free Blueprints for Sustainable Development OHO e.V.	Part	Steel C45	1	
	LICENCE	SCALE	SHEET	
	CC-BY-SA 4.0	2:1	27/55	

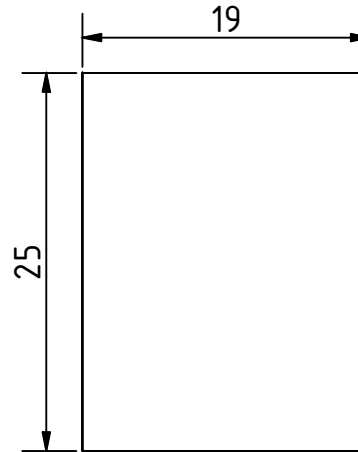
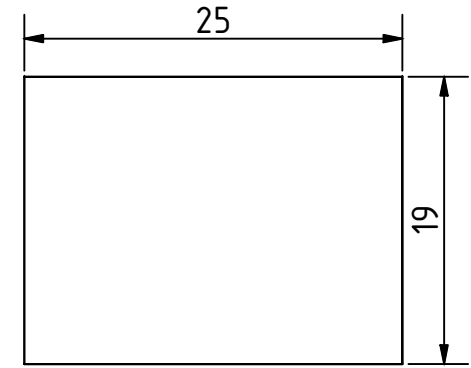
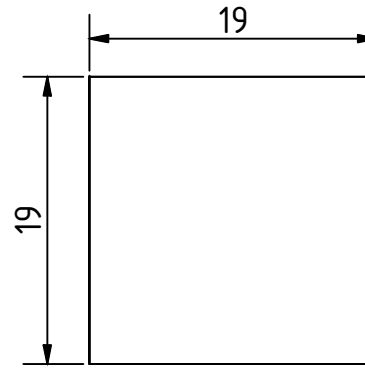
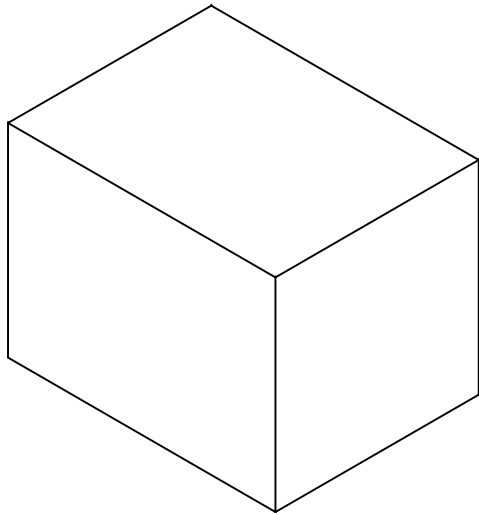

Note: All units in mm.

PROJECT	CREATED BY	APPROVED BY	DATE	VERSION
Bandsaw wheel - Dia 12 inch	E. Araujo	A. Morillo	13/09/2021	1.0
PART NAME	FILE NAME			POS
Wood block	jah_bsw_bandsaw_wheel_-_dia_12_inch.dwg			2.10
PUBLISHED BY	DOC. TYPE	MATERIAL	QUANTITY	
 OPEN HARDWARE OBSERVATORY Free Blueprints for Sustainable Development OHO e.V.	Part	Plywood	1	
	LICENCE	SCALE	SHEET	
	CC-BY-SA 4.0	2:1	28/55	

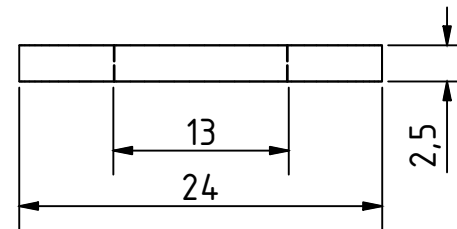
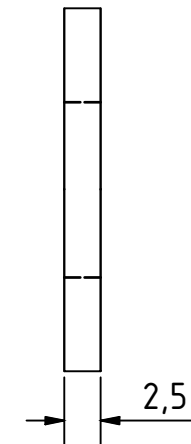
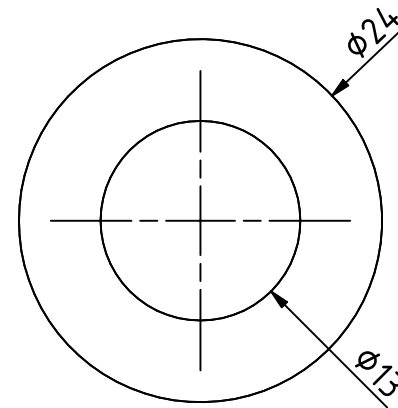
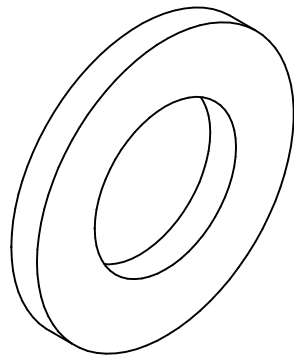

Note: All units in mm.

PROJECT	CREATED BY	APPROVED BY	DATE	VERSION
Bandsaw wheel - Dia 12 inch	E. Araujo	A. Morillo	13/09/2021	1.0
PART NAME	FILE NAME			POS
Rubber washer	jah_bsw_bandsaw_wheel_-_dia_12_inch.dwg			2.17
PUBLISHED BY	DOC. TYPE	MATERIAL	QUANTITY	
 OPEN HARDWARE OBSERVATORY Free Blueprints for Sustainable Development OHO e.V.	Part	Rubber	1	
	LICENCE	SCALE	SHEET	
	CC-BY-SA 4.0	2:1	29/55	

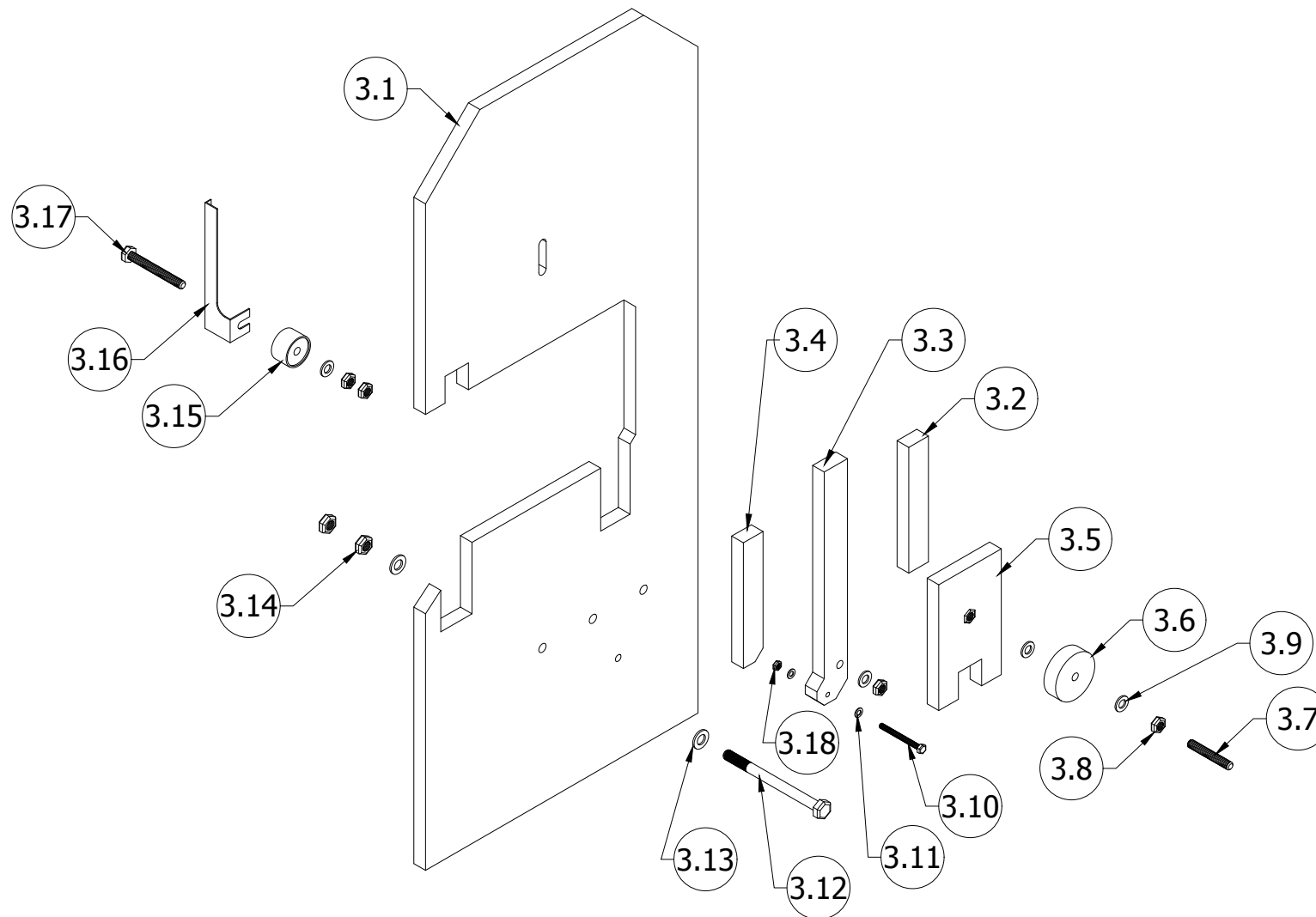

Note: All units in mm.

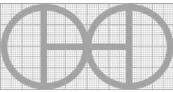
PROJECT	CREATED BY	APPROVED BY	DATE	VERSION
Bandsaw wheel - Dia 12 inch	E. Araujo	A. Morillo	13/09/2021	1.0
PART NAME	FILE NAME			POS
Front side panel	jah_bsw_bandsaw_wheel_-_dia_12_inch.dwg			3.0
PUBLISHED BY	DOC. TYPE	MATERIAL	QUANTITY	
 OPEN HARDWARE OBSERVATORY Free Blueprints for Sustainable Development OHO e.V.	Assembly		1	
	LICENCE	SCALE	SHEET	
	CC-BY-SA 4.0	1:12.5	30/55	

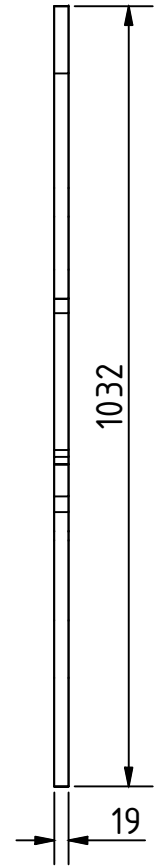
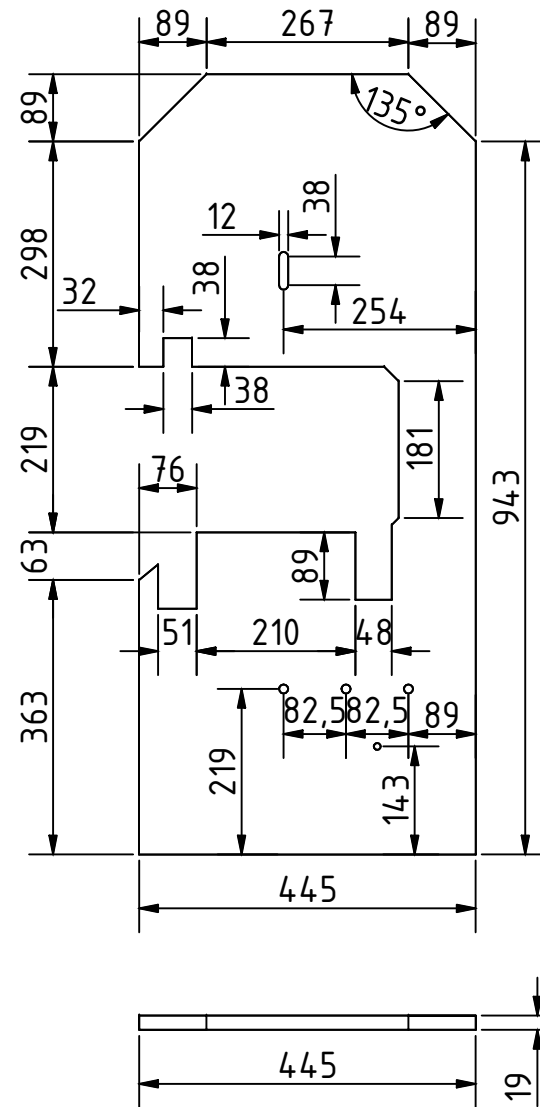
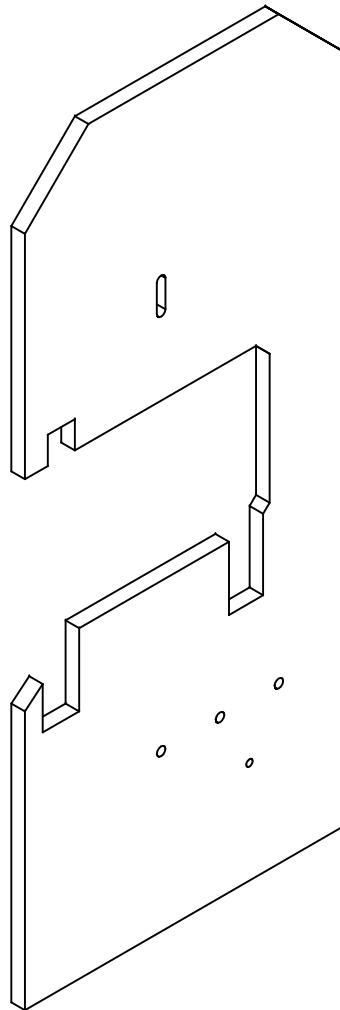

Note: All units in mm.

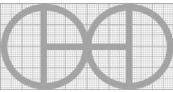
PROJECT	CREATED BY	APPROVED BY	DATE	VERSION
Bandsaw wheel - Dia 12 inch	E. Araujo	A. Morillo	13/09/2021	1.0
PART NAME	FILE NAME			POS
Front panel	jah_bsw_bandsaw_wheel_-_dia_12_inch.dwg			3.1
PUBLISHED BY	DOC. TYPE	MATERIAL	QUANTITY	
 OPEN HARDWARE OBSERVATORY Free Blueprints for Sustainable Development	Part	Plywood	1	
	LICENCE	SCALE	SHEET	
OHO e.V.	CC-BY-SA 4.0	1:10	31/55	

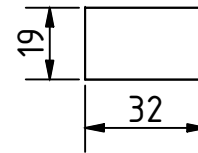
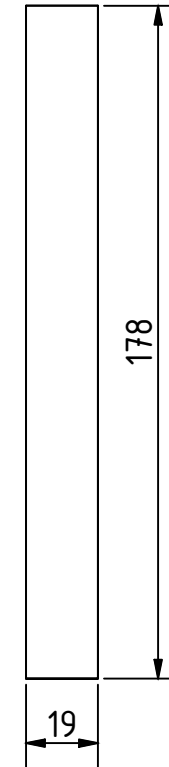
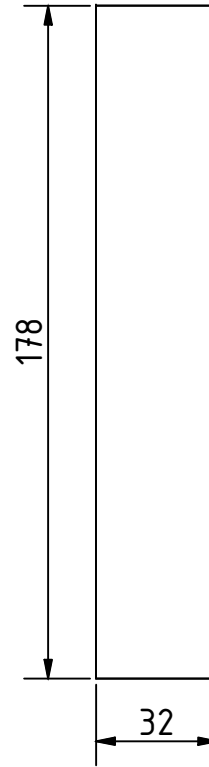
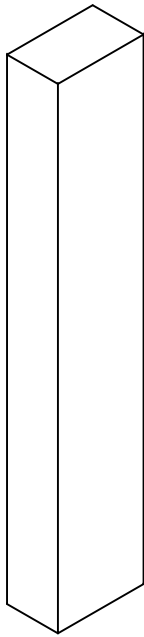

Note: All units in mm.

PROJECT	CREATED BY	APPROVED BY	DATE	VERSION
Bandsaw wheel - Dia 12 inch	E. Araujo	A. Morillo	13/09/2021	1.0
PART NAME	FILE NAME			POS
Panel 1	jah_bsw_bandsaw_wheel_-_dia_12_inch.dwg			3.2
PUBLISHED BY	DOC. TYPE	MATERIAL	QUANTITY	
 OPEN HARDWARE OBSERVATORY Free Blueprints for Sustainable Development OHO e.V.	Part	Plywood	1	
	LICENCE	SCALE	SHEET	
	CC-BY-SA 4.0	1:2	32/55	

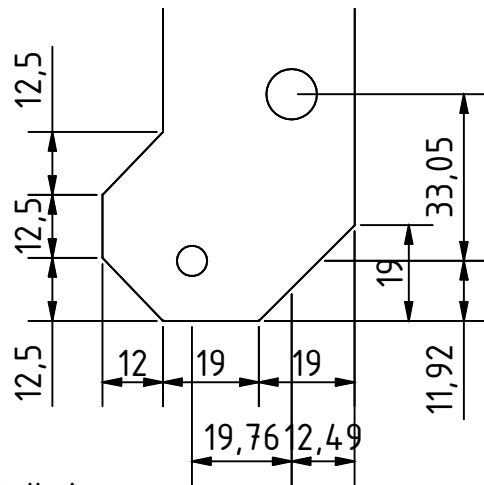
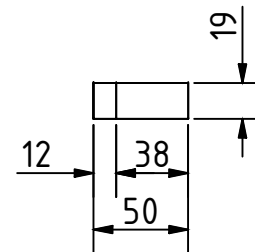
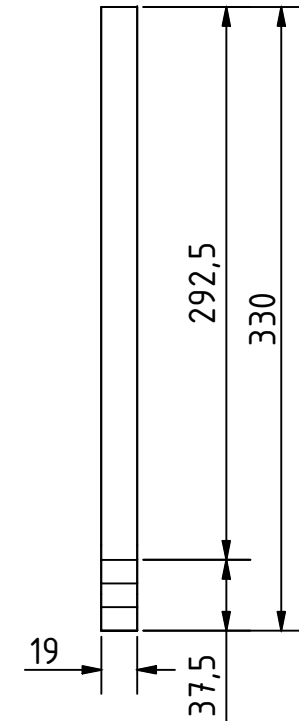
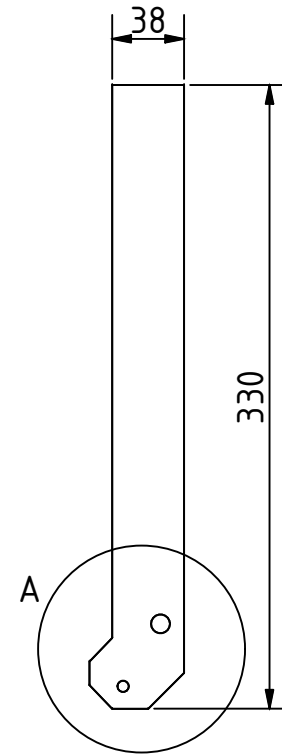
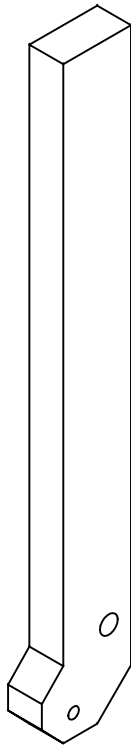

Detail A

Note: All units in mm.

PROJECT	CREATED BY	APPROVED BY	DATE	VERSION
Bandsaw wheel - Dia 12 inch	E. Araujo	A. Morillo	13/09/2021	1.0
PART NAME	FILE NAME			POS
Panel 2	jah_bsw_bandsaw_wheel_-_dia_12_inch.dwg			3.3
PUBLISHED BY	DOC. TYPE	MATERIAL	QUANTITY	
 OPEN HARDWARE OBSERVATORY Free Blueprints for Sustainable Development	Part	Plywood	1	
	LICENCE	SCALE	SHEET	
OHO e.V.	CC-BY-SA 4.0	1:4	33/55	

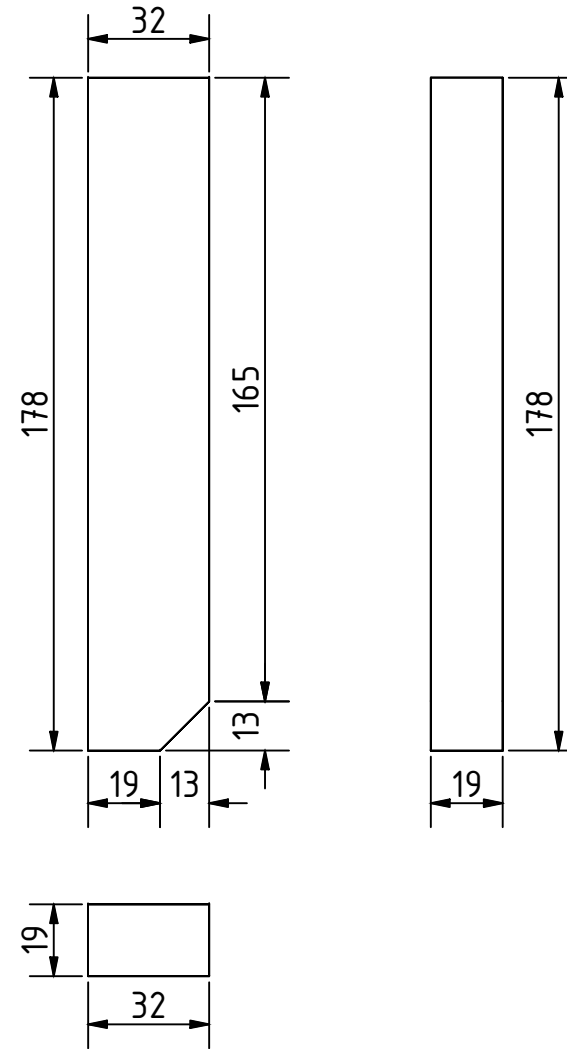
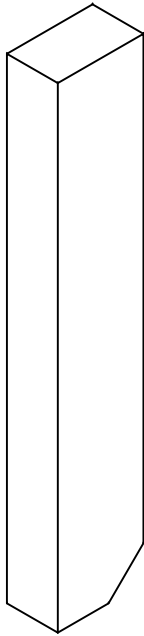

Note: All units in mm.

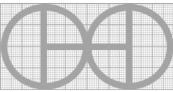
PROJECT	CREATED BY	APPROVED BY	DATE	VERSION
Bandsaw wheel - Dia 12 inch	E. Araujo	A. Morillo	13/09/2021	1.0
PART NAME	FILE NAME			POS
Panel 3	jah_bsw_bandsaw_wheel_-_dia_12_inch.dwg			3.4
PUBLISHED BY	DOC. TYPE	MATERIAL	QUANTITY	
 OPEN HARDWARE OBSERVATORY Free Blueprints for Sustainable Development	Part	Plywood	1	
	LICENCE	SCALE	SHEET	
OHO e.V.	CC-BY-SA 4.0	1:2	34/55	

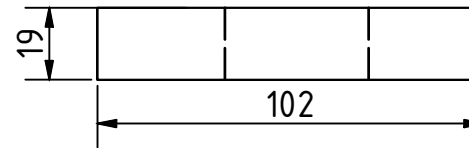
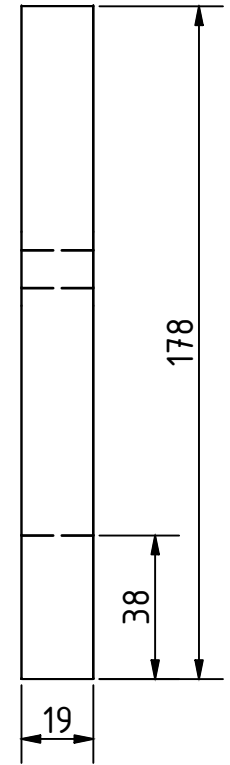
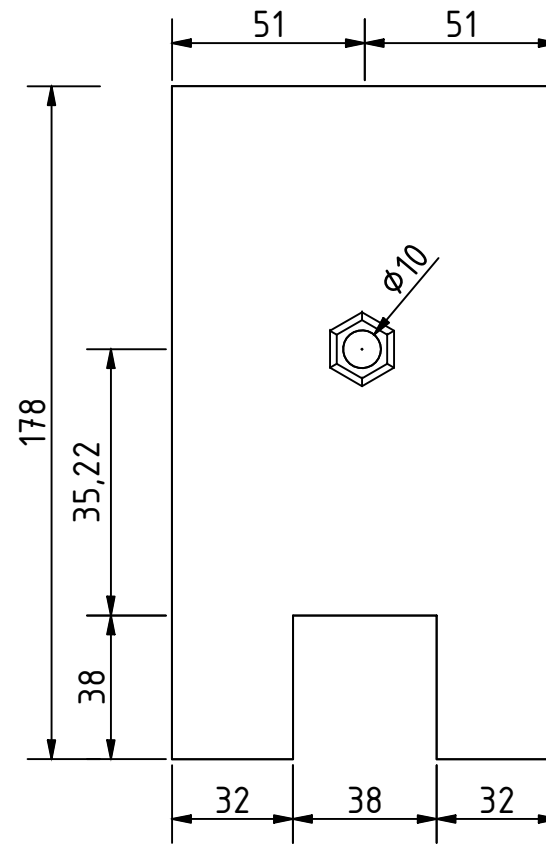
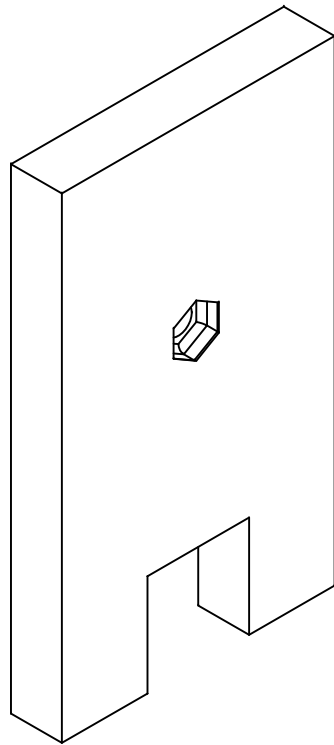

Note: All units in mm.

PROJECT	CREATED BY	APPROVED BY	DATE	VERSION
Bandsaw wheel - Dia 12 inch	E. Araujo	A. Morillo	13/09/2021	1.0
PART NAME	FILE NAME			POS
Panel 4	jah_bsw_bandsaw_wheel_-_dia_12_inch.dwg			3.5
PUBLISHED BY	DOC. TYPE	MATERIAL	QUANTITY	
 OPEN HARDWARE OBSERVATORY Free Blueprints for Sustainable Development OHO e.V.	Part	Plywood	1	
	LICENCE	SCALE	SHEET	
	CC-BY-SA 4.0	1:2	35/55	

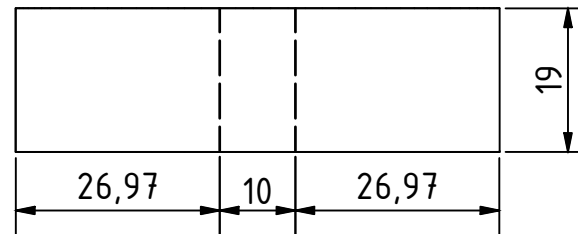
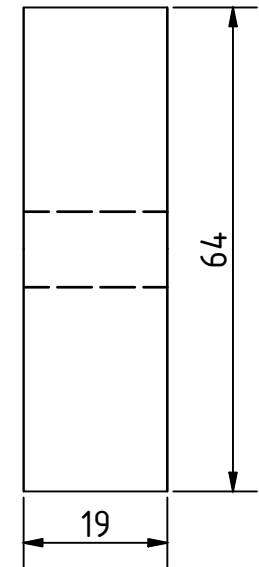
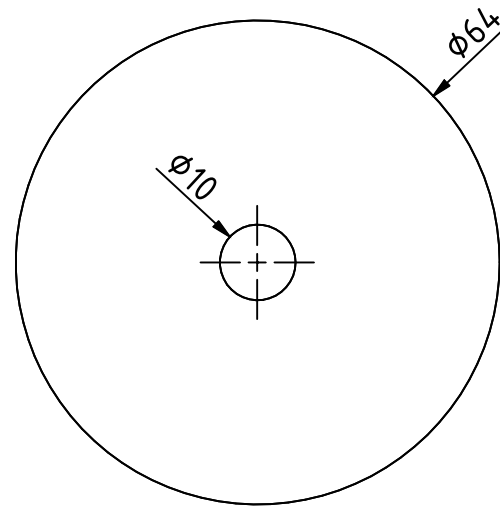
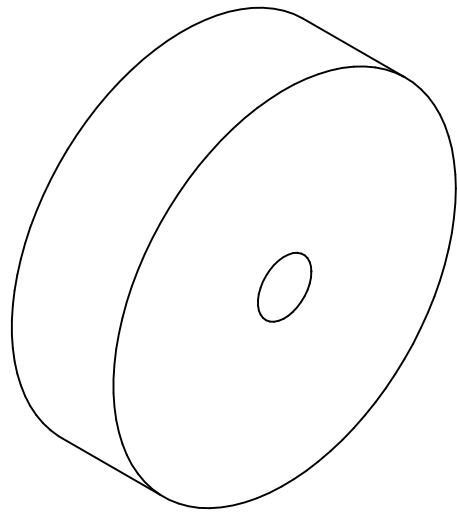

Note: All units in mm.

PROJECT	CREATED BY	APPROVED BY	DATE	VERSION
Bandsaw wheel - Dia 12 inch	E. Araujo	A. Morillo	13/09/2021	1.0
PART NAME	FILE NAME			POS
Wood hand wheel	jah_bsw_bandsaw_wheel_-_dia_12_inch.dwg			3.6
PUBLISHED BY	DOC. TYPE	MATERIAL	QUANTITY	
 OPEN HARDWARE OBSERVATORY Free Blueprints for Sustainable Development OHO e.V.	Part	Plywood	1	
	LICENCE	SCALE	SHEET	
	CC-BY-SA 4.0	1:1	36/55	

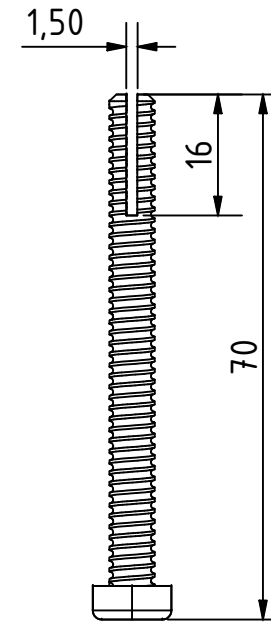
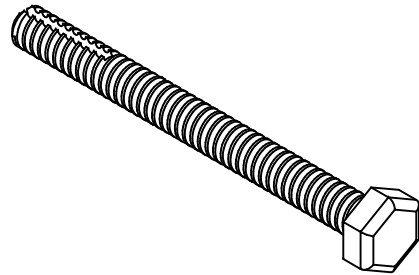

Note: All units in mm.

PROJECT	CREATED BY	APPROVED BY	DATE	VERSION
Bandsaw wheel - Dia 12 inch	E. Araujo	A. Morillo	13/09/2021	1.0
PART NAME	FILE NAME			POS
Bolt 1	jah_bsw_bandsaw_wheel_-_dia_12_inch.dwg			3.10
PUBLISHED BY	DOC. TYPE	MATERIAL	QUANTITY	
 OPEN HARDWARE OBSERVATORY Free Blueprints for Sustainable Development OHO e.V.	Part	DIN 933	1	
	LICENCE	SCALE	SHEET	
	CC-BY-SA 4.0	1:1	37/55	

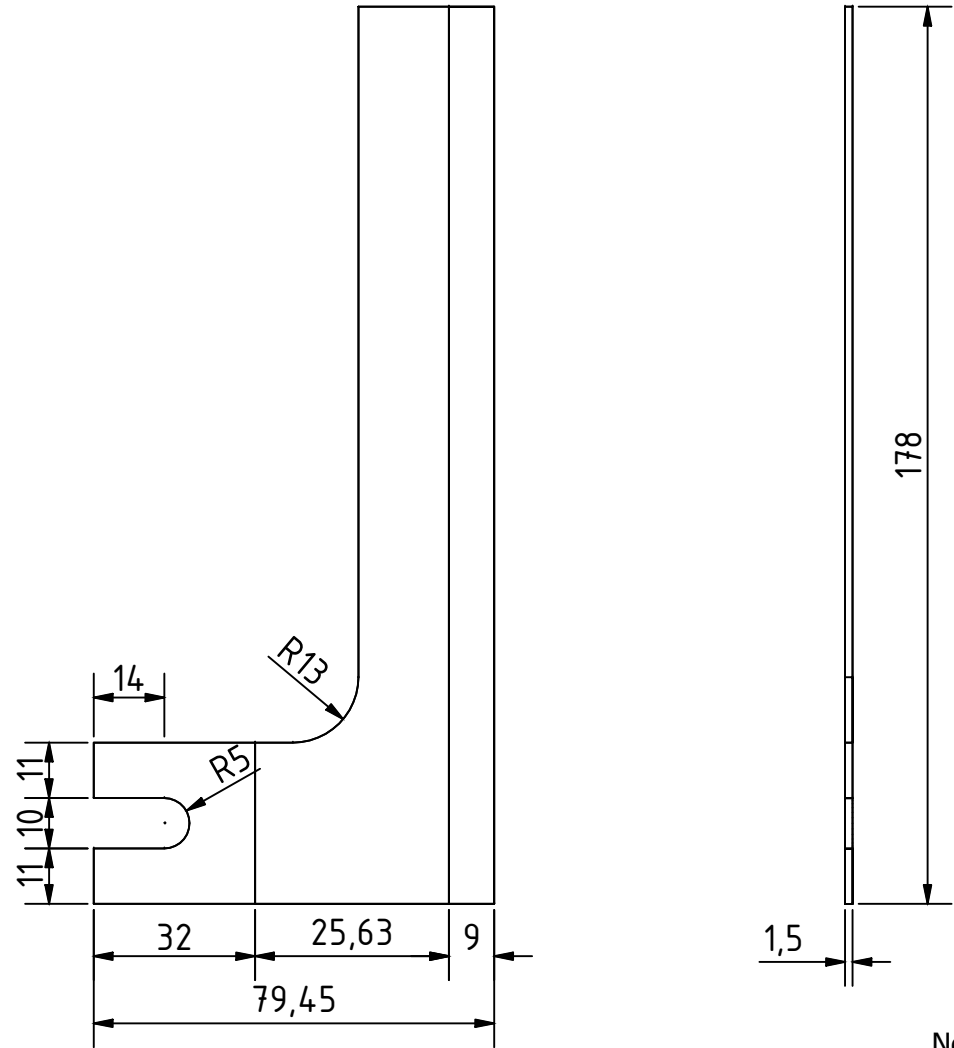
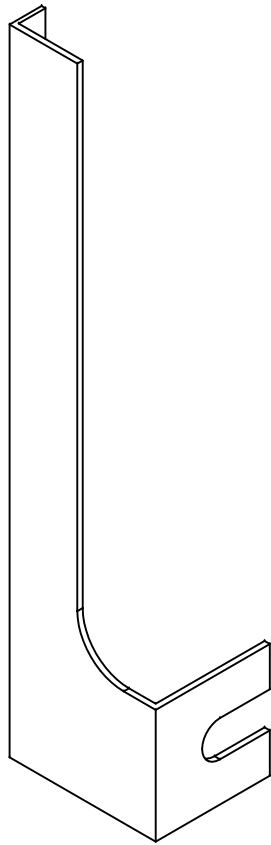

Note: All units in mm.

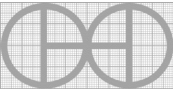
PROJECT	CREATED BY	APPROVED BY	DATE	VERSION
Bandsaw wheel - Dia 12 inch	E. Araujo	A. Morillo	13/09/2021	1.0
PART NAME	FILE NAME			POS
Front blade guard	jah_bsw_bandsaw_wheel_-_dia_12_inch.dwg			3.16
PUBLISHED BY	DOC. TYPE	MATERIAL	QUANTITY	
 OPEN HARDWARE OBSERVATORY Free Blueprints for Sustainable Development OHO e.V.	Part	Steel C45	1	
	LICENCE	SCALE	SHEET	
	CC-BY-SA 4.0	1:1.5	38/55	

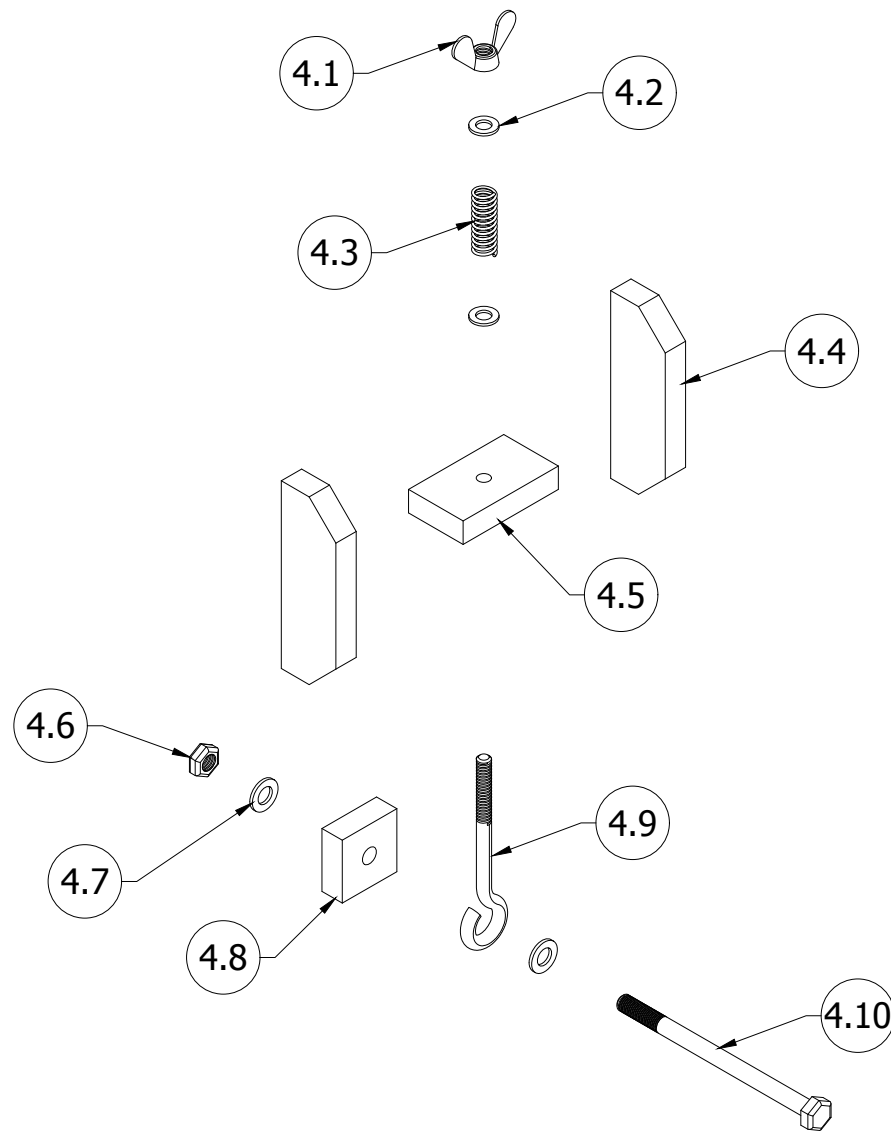

Note: All units in mm.

PROJECT	CREATED BY	APPROVED BY	DATE	VERSION
Bandsaw wheel - Dia 12 inch	E. Araujo	A. Morillo	13/09/2021	1.0
PART NAME	FILE NAME			POS
Pulley support	jah_bsw_bandsaw_wheel_-_dia_12_inch.dwg			4.0
PUBLISHED BY	DOC. TYPE	MATERIAL	QUANTITY	
 OPEN HARDWARE OBSERVATORY Free Blueprints for Sustainable Development OHO e.V.	Assembly		1	
	LICENCE	SCALE	SHEET	
	CC-BY-SA 4.0	1:5	39/55	

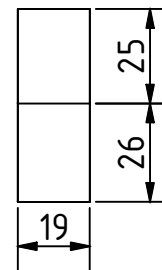
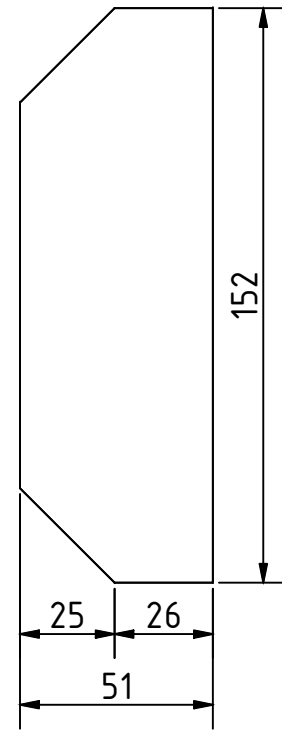
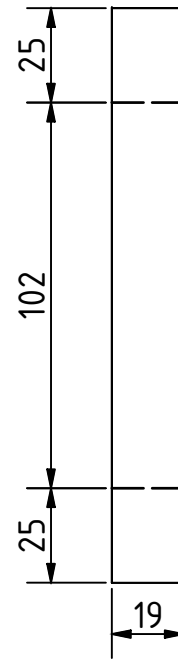
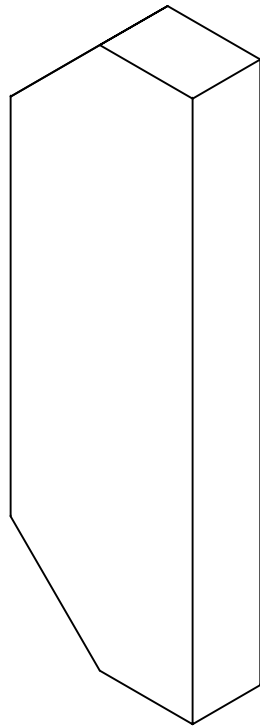

Note: All units in mm.

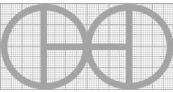
PROJECT	CREATED BY	APPROVED BY	DATE	VERSION
Bandsaw wheel - Dia 12 inch	E. Araujo	A. Morillo	13/09/2021	1.0
PART NAME	FILE NAME			POS
Panel 1	jah_bsw_bandsaw_wheel_-_dia_12_inch.dwg			4.4
PUBLISHED BY	DOC. TYPE	MATERIAL		QUANTITY
 OPEN HARDWARE OBSERVATORY Free Blueprints for Sustainable Development	Part	Plywood		2
	LICENCE	SCALE	SHEET	
OHO e.V.	CC-BY-SA 4.0	1:2	40/55	

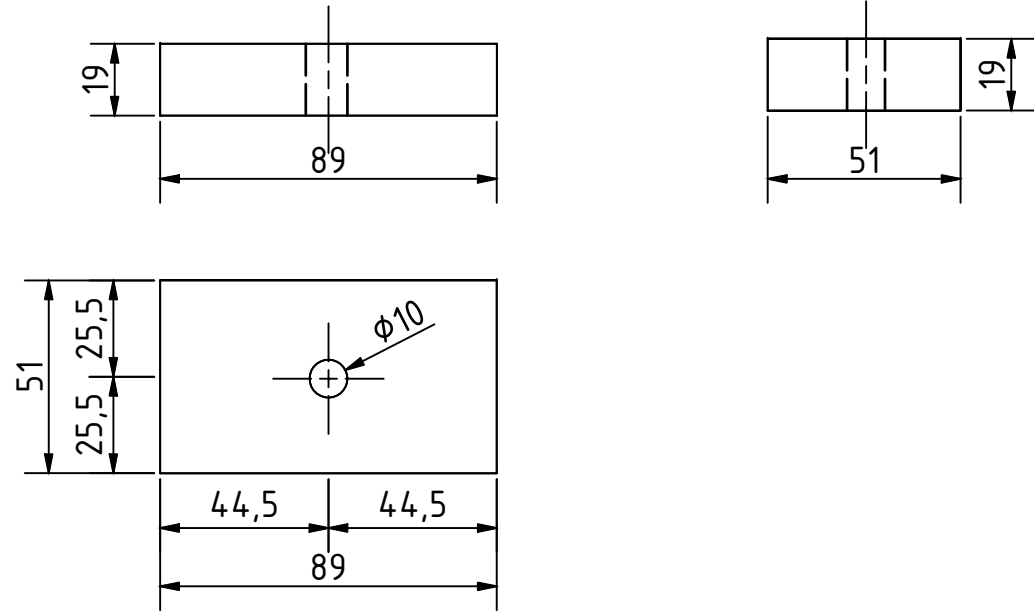
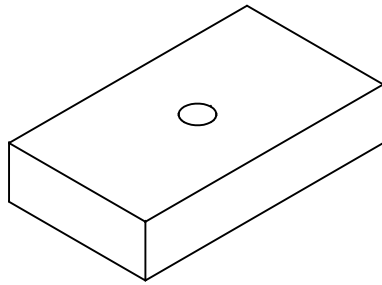

Note: All units in mm.

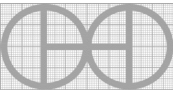
PROJECT	CREATED BY	APPROVED BY	DATE	VERSION
Bandsaw wheel - Dia 12 inch	E. Araujo	A. Morillo	13/09/2021	1.0
PART NAME	FILE NAME			POS
Panel 2	jah_bsw_bandsaw_wheel_-_dia_12_inch.dwg			4.5
PUBLISHED BY	DOC. TYPE	MATERIAL	QUANTITY	
 OPEN HARDWARE OBSERVATORY Free Blueprints for Sustainable Development OHO e.V.	Part	Plywood	1	
	LICENCE	SCALE	SHEET	
	CC-BY-SA 4.0	1:2	41/55	

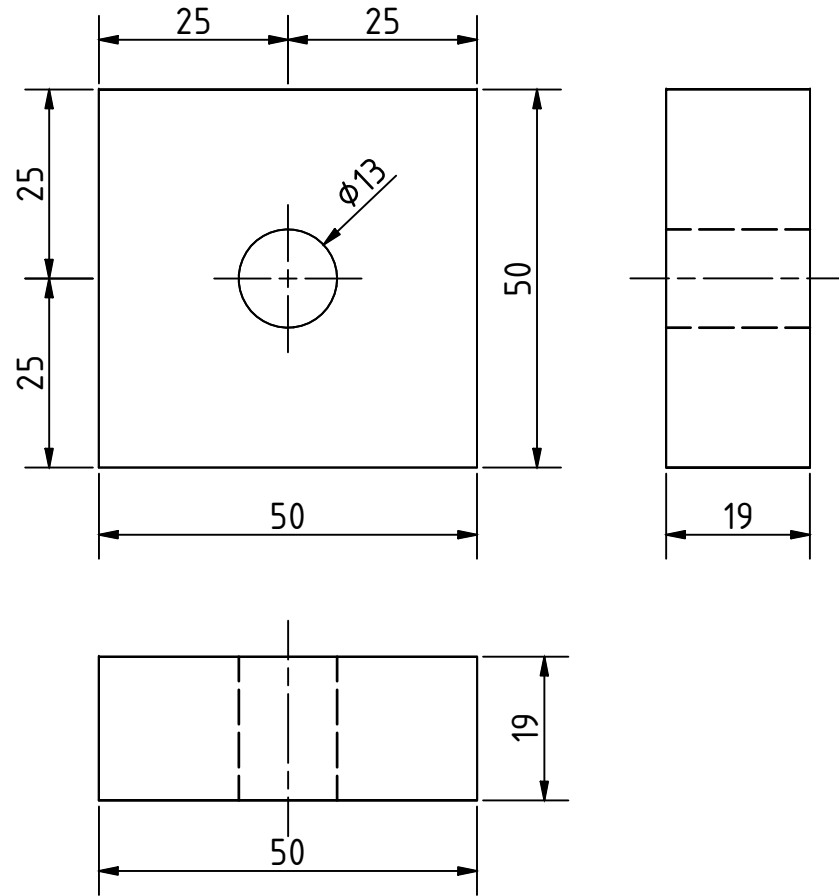
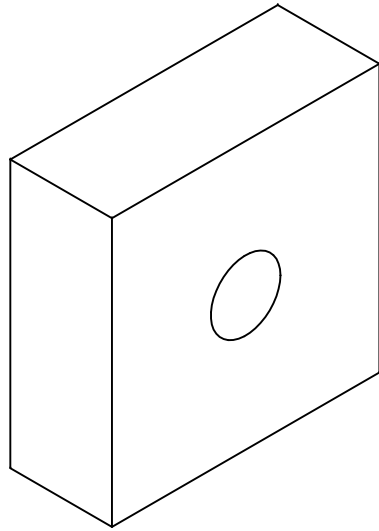

Note: All units in mm.

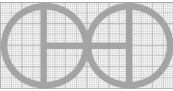
PROJECT	CREATED BY	APPROVED BY	DATE	VERSION
Bandsaw wheel - Dia 12 inch	E. Araujo	A. Morillo	13/09/2021	1.0
PART NAME	FILE NAME			POS
Panel 3	jah_bsw_bandsaw_wheel_-_dia_12_inch.dwg			1.4
PUBLISHED BY	DOC. TYPE	MATERIAL	QUANTITY	
 OPEN HARDWARE OBSERVATORY Free Blueprints for Sustainable Development	Part	Plywood	1	
	LICENCE	SCALE	SHEET	
OHO e.V.	CC-BY-SA 4.0	1:1	42/55	

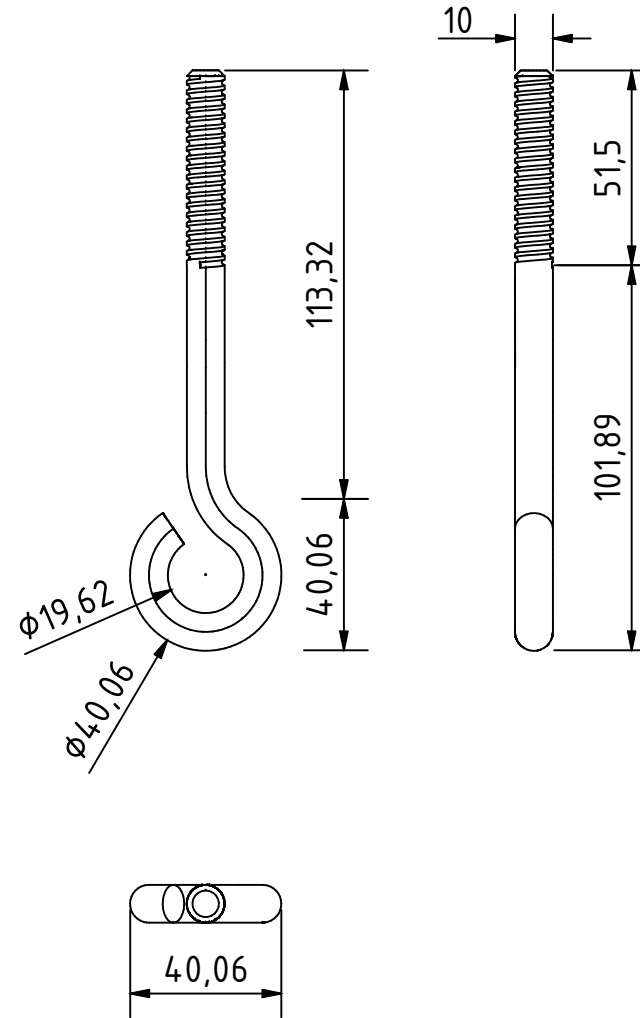
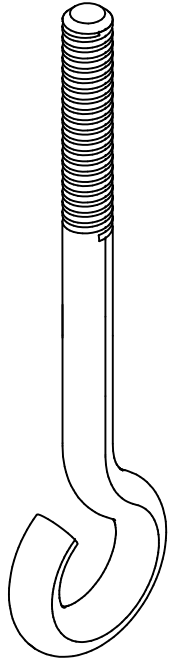

Note: All units in mm.

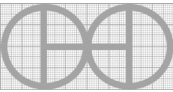
PROJECT	CREATED BY	APPROVED BY	DATE	VERSION
Bandsaw wheel - Dia 12 inch	E. Araujo	A. Morillo	13/09/2021	1.0
PART NAME	FILE NAME			POS
Eyebolt 2	jah_bsw_bandsaw_wheel_-_dia_12_inch.dwg			4.9
PUBLISHED BY	DOC. TYPE	MATERIAL	QUANTITY	
 OPEN HARDWARE OBSERVATORY Free Blueprints for Sustainable Development OHO e.V.	Part	Steel A53	1	
	LICENCE	SCALE	SHEET	
	CC-BY-SA 4.0	1:2	43/55	

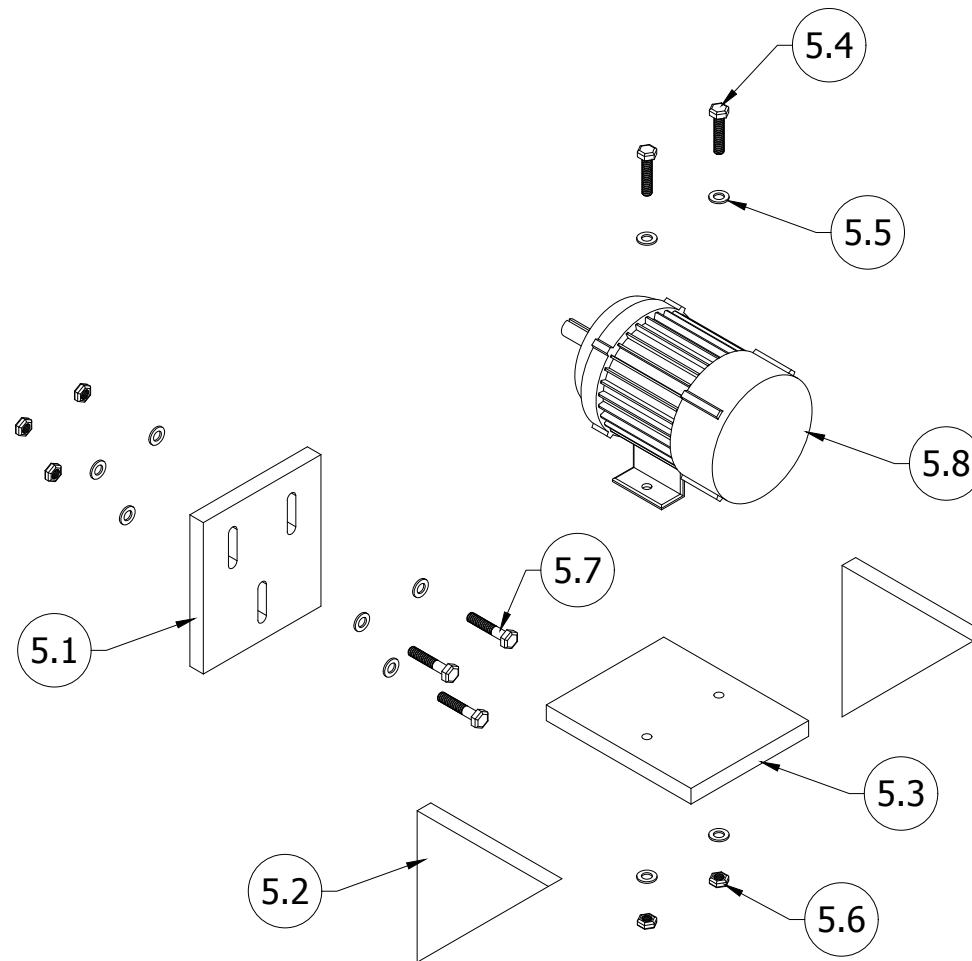

Note: All units in mm.

PROJECT	CREATED BY	APPROVED BY	DATE	VERSION
Bandsaw wheel - Dia 12 inch	E. Araujo	A. Morillo	13/09/2021	1.0
PART NAME	FILE NAME			POS
Motor support	jah_bsw_bandsaw_wheel_-_dia_12_inch.dwg			5.0
PUBLISHED BY	DOC. TYPE	MATERIAL	QUANTITY	
 OPEN HARDWARE OBSERVATORY Free Blueprints for Sustainable Development OHO e.V.	Assembly		1	
	LICENCE	SCALE	SHEET	
	CC-BY-SA 4.0	1:7.5	44/55	

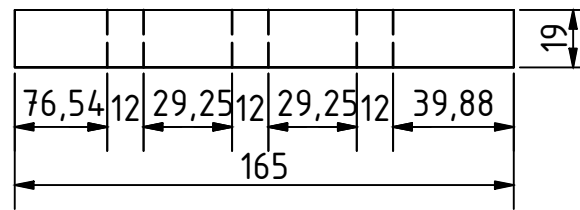
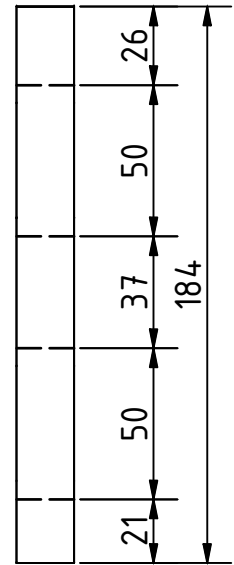
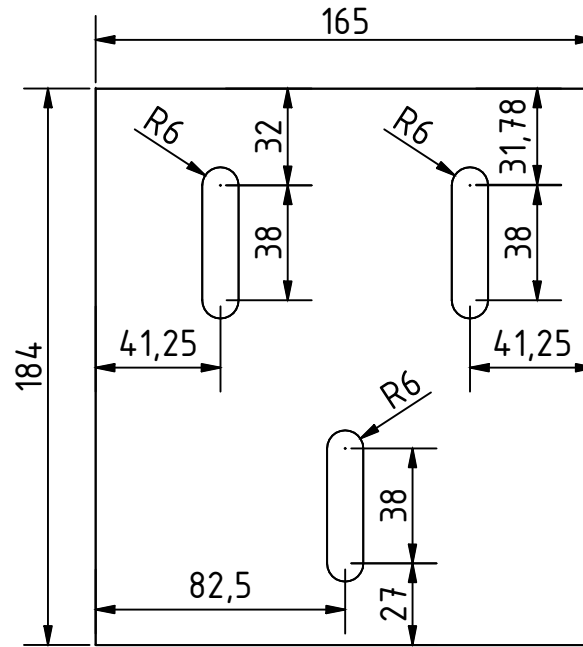
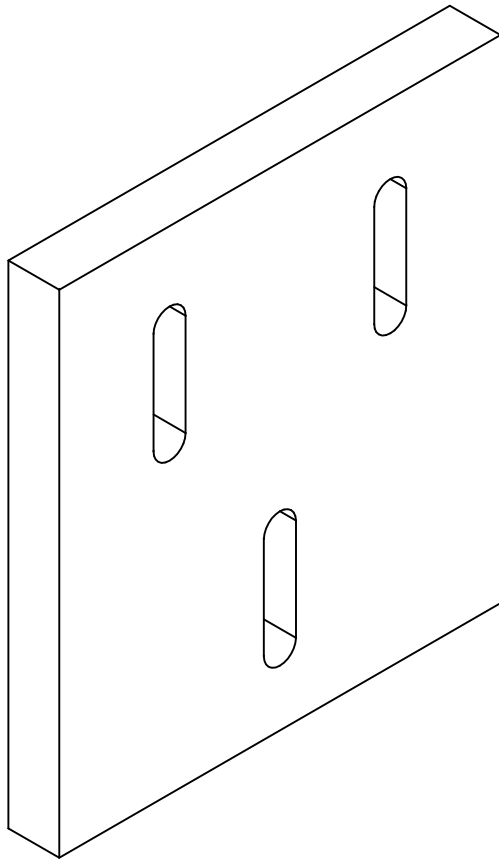

Note: All units in mm.

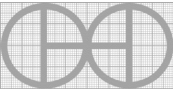
PROJECT	CREATED BY	APPROVED BY	DATE	VERSION
Bandsaw wheel - Dia 12 inch	E. Araujo	A. Morillo	13/09/2021	1.0
PART NAME	FILE NAME			POS
Motor base 1	jah_bsw_bandsaw_wheel_-_dia_12_inch.dwg			5.1
PUBLISHED BY	DOC. TYPE	MATERIAL	QUANTITY	
 OPEN HARDWARE OBSERVATORY Free Blueprints for Sustainable Development	Part	Plywood	1	
	LICENCE	SCALE	SHEET	
OHO e.V.	CC-BY-SA 4.0	1:2.5	45/55	

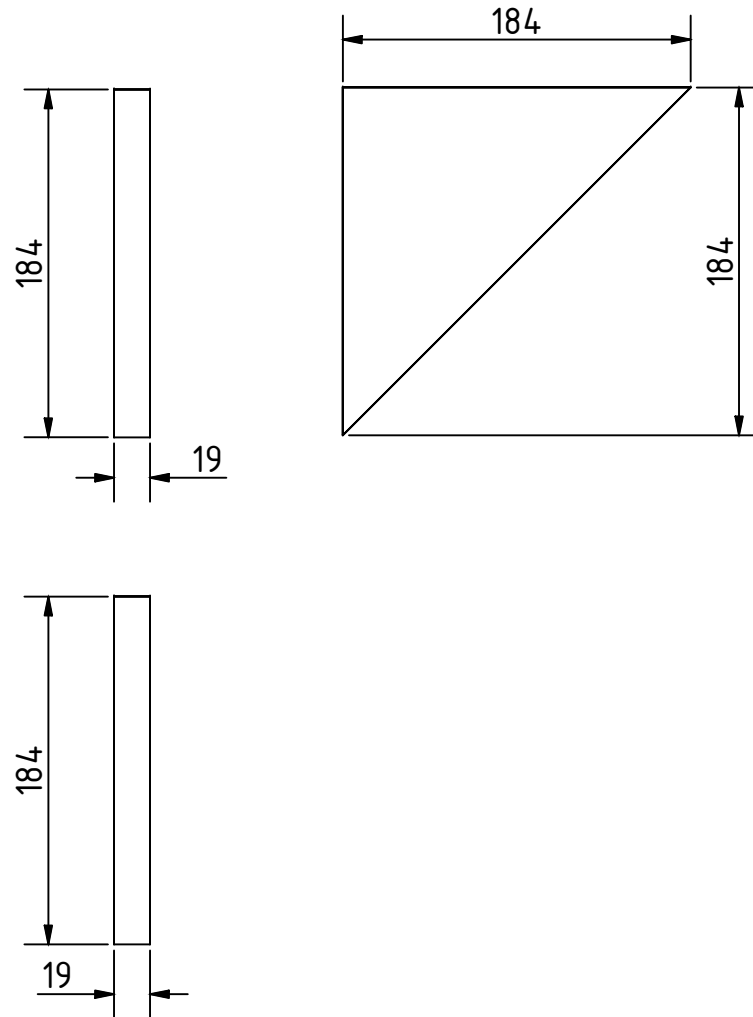
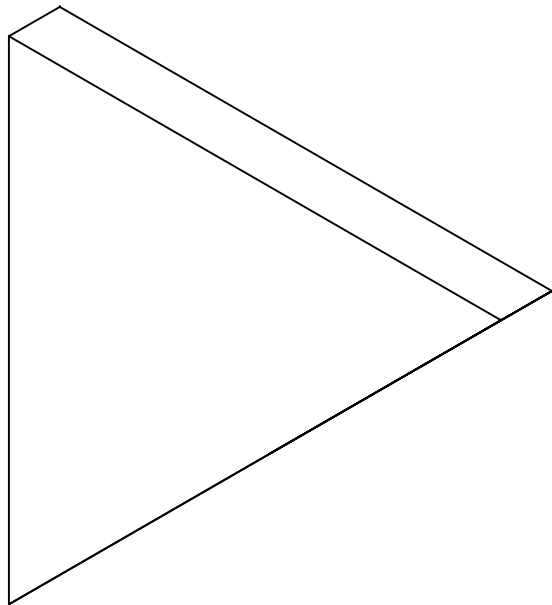

Note: All units in mm.

PROJECT	CREATED BY	APPROVED BY	DATE	VERSION
Bandsaw wheel - Dia 12 inch	E. Araujo	A. Morillo	13/09/2021	1.0
PART NAME	FILE NAME			POS
Motor base 2	jah_bsw_bandsaw_wheel_-_dia_12_inch.dwg			5.2
PUBLISHED BY	DOC. TYPE	MATERIAL	QUANTITY	
 OPEN HARDWARE OBSERVATORY Free Blueprints for Sustainable Development	Part	Plywood	2	
	LICENCE	SCALE	SHEET	
OHO e.V.	CC-BY-SA 4.0	1:4	46/55	

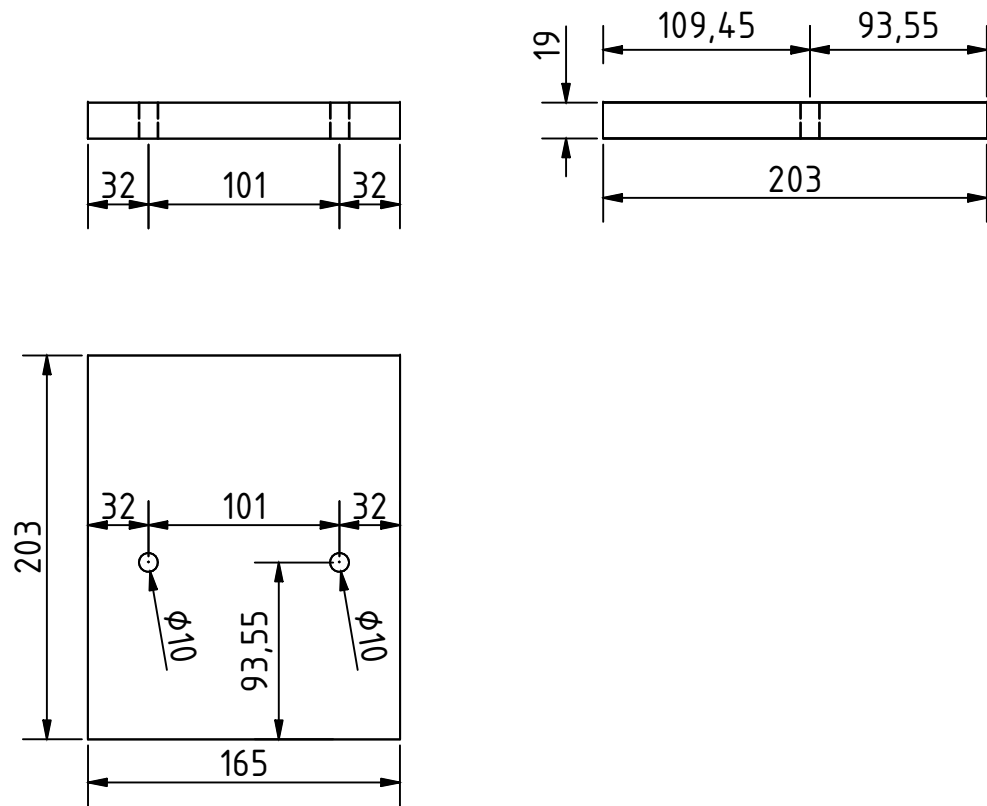
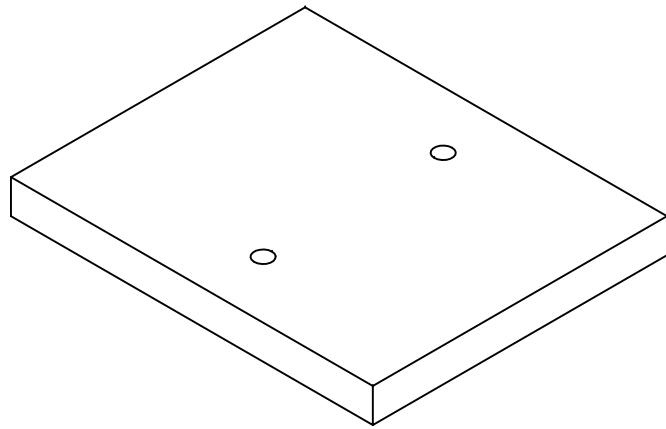

Note: All units in mm.

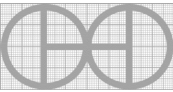
PROJECT	CREATED BY	APPROVED BY	DATE	VERSION
Bandsaw wheel - Dia 12 inch	E. Araujo	A. Morillo	13/09/2021	1.0
PART NAME	FILE NAME			POS
Motor base 3	jah_bsw_bandsaw_wheel_-_dia_12_inch.dwg			5.3
PUBLISHED BY	DOC. TYPE	MATERIAL	QUANTITY	
 OPEN HARDWARE OBSERVATORY Free Blueprints for Sustainable Development	Part	Plywood	1	
	LICENCE	SCALE	SHEET	
OHO e.V.	CC-BY-SA 4.0	1:4	47/55	

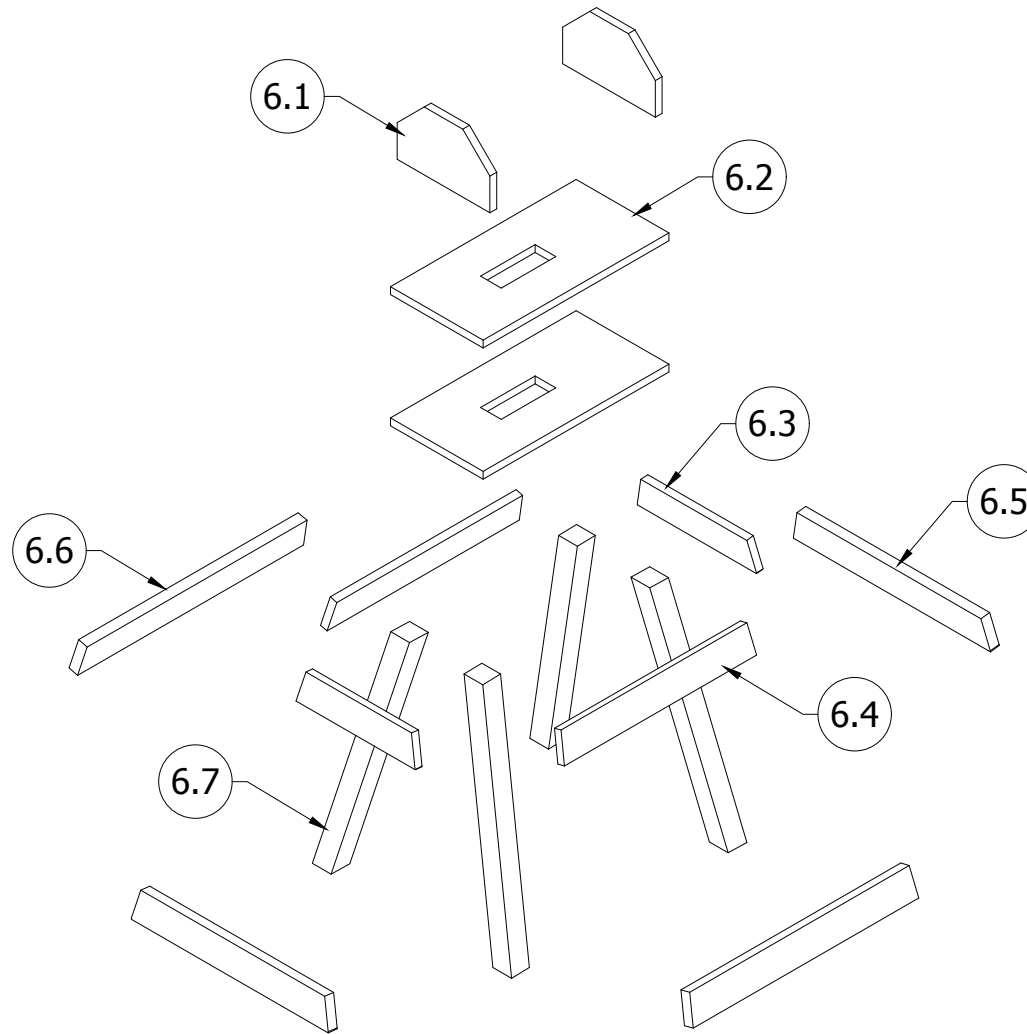

Note: All units in mm.

PROJECT	CREATED BY	APPROVED BY	DATE	VERSION
Bandsaw wheel - Dia 12 inch	E. Araujo	A. Morillo	13/09/2021	1.0
PART NAME	FILE NAME			POS
Saw support	jah_bsw_bandsaw_wheel_-_dia_12_inch.dwg			6.0
PUBLISHED BY	DOC. TYPE	MATERIAL	QUANTITY	
 OPEN HARDWARE OBSERVATORY Free Blueprints for Sustainable Development OHO e.V.	Assembly		1	
	LICENCE	SCALE	SHEET	
	CC-BY-SA 4.0	1:7.5	48/55	

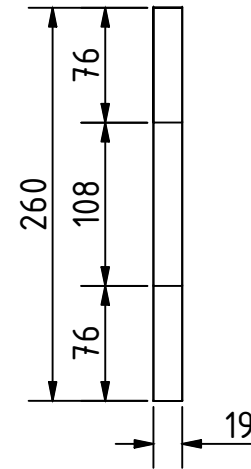
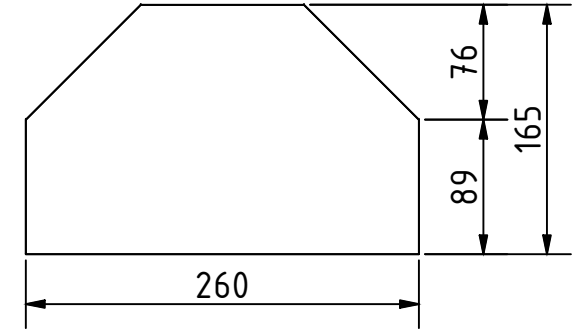
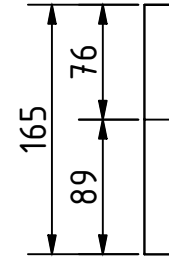
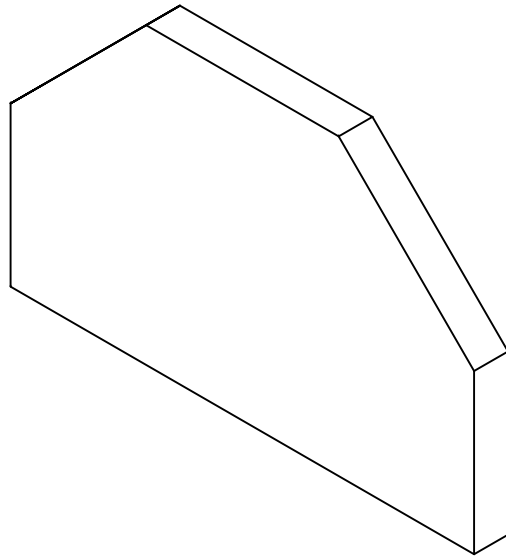

Note: All units in mm.

PROJECT	CREATED BY	APPROVED BY	DATE	VERSION
Bandsaw wheel - Dia 12 inch	E. Araujo	A. Morillo	13/09/2021	1.0
PART NAME	FILE NAME			POS
Saw base 1	jah_bsw_bandsaw_wheel_-_dia_12_inch.dwg			6.1
PUBLISHED BY	DOC. TYPE	MATERIAL	QUANTITY	
 OPEN HARDWARE OBSERVATORY Free Blueprints for Sustainable Development OHO e.V.	Part	Plywood	2	
	LICENCE	SCALE	SHEET	
	CC-BY-SA 4.0	1:5	49/55	

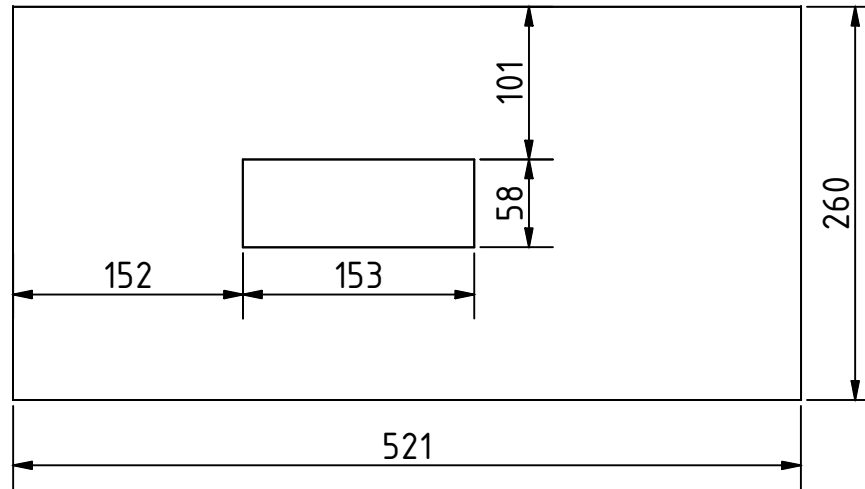
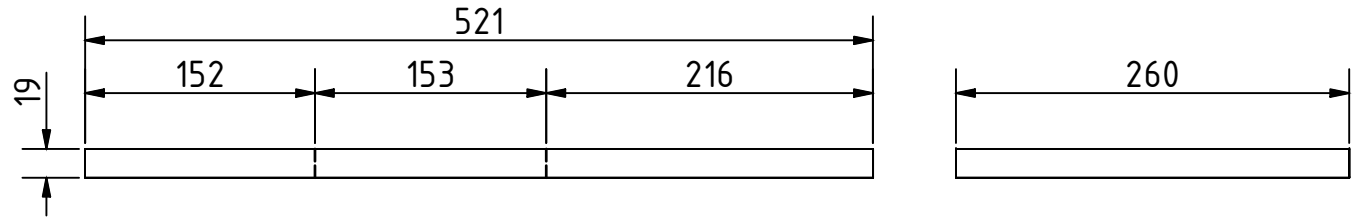
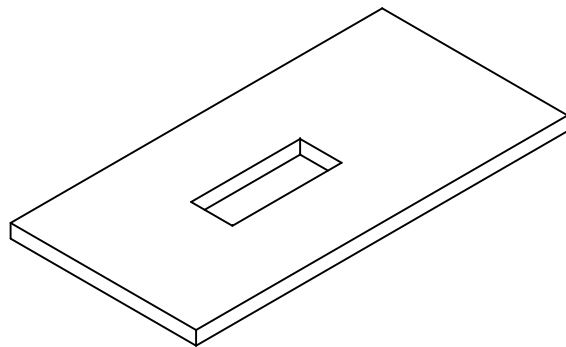

Note: All units in mm.

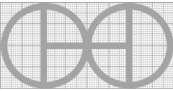
PROJECT	CREATED BY	APPROVED BY	DATE	VERSION
Bandsaw wheel - Dia 12 inch	E. Araujo	A. Morillo	13/09/2021	1.0
PART NAME	FILE NAME			POS
Saw base 2	jah_bsw_bandsaw_wheel_-_dia_12_inch.dwg			6.2
PUBLISHED BY	DOC. TYPE	MATERIAL	QUANTITY	
 OPEN HARDWARE OBSERVATORY Free Blueprints for Sustainable Development OHO e.V.	Part	Plywood	2	
	LICENCE	SCALE	SHEET	
	CC-BY-SA 4.0	1:5	50/55	

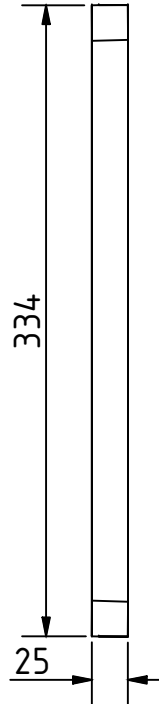
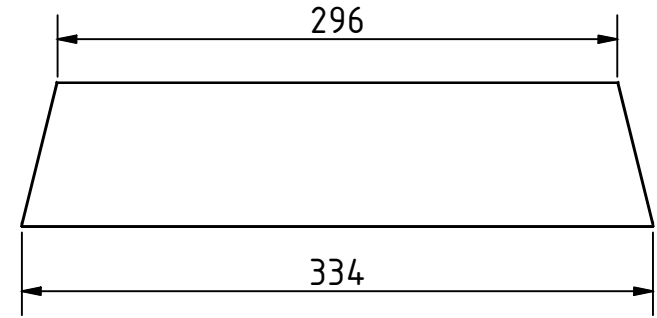
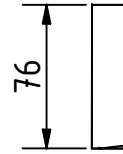
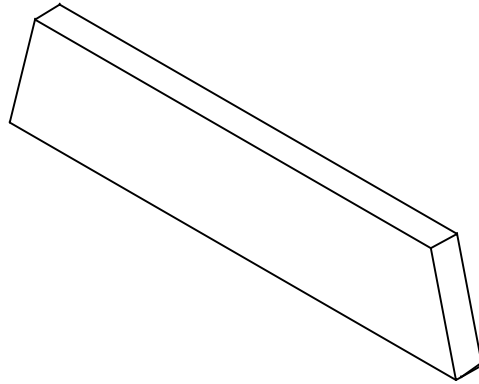

Note: All units in mm.

PROJECT	CREATED BY	APPROVED BY	DATE	VERSION
Bandsaw wheel - Dia 12 inch	E. Araujo	A. Morillo	13/09/2021	1.0
PART NAME	FILE NAME			POS
Strips 1	jah_bsw_bandsaw_wheel_-_dia_12_inch.dwg			6.3
PUBLISHED BY	DOC. TYPE	MATERIAL	QUANTITY	
 OPEN HARDWARE OBSERVATORY Free Blueprints for Sustainable Development OHO e.V.	Part	Plywood	2	
	LICENCE	SCALE	SHEET	
	CC-BY-SA 4.0	1:4	51/55	

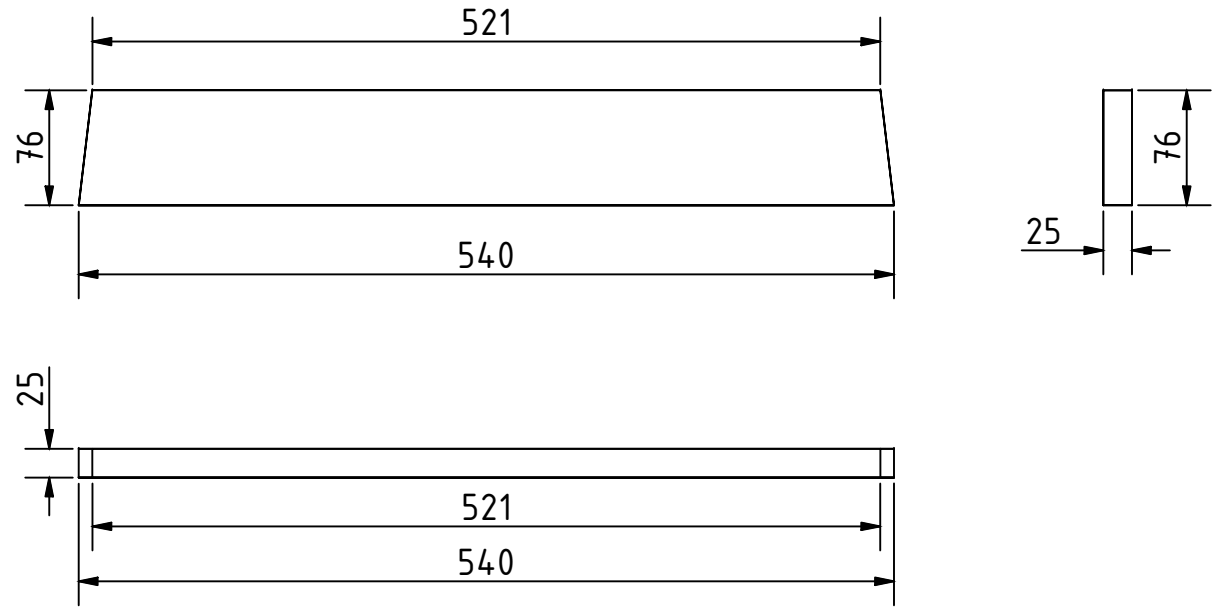
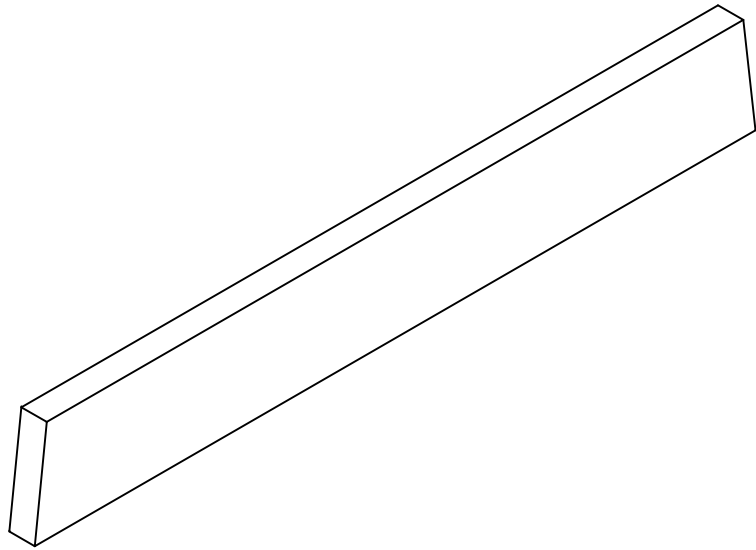

Note: All units in mm.

PROJECT	CREATED BY	APPROVED BY	DATE	VERSION
Bandsaw wheel - Dia 12 inch	E. Araujo	A. Morillo	13/09/2021	1.0
PART NAME	FILE NAME			POS
Strips 2	jah_bsw_bandsaw_wheel_-_dia_12_inch.dwg			6.4
PUBLISHED BY	DOC. TYPE	MATERIAL	QUANTITY	
 OPEN HARDWARE OBSERVATORY Free Blueprints for Sustainable Development	Part	Plywood	2	
	LICENCE	SCALE	SHEET	
OHO e.V.	CC-BY-SA 4.0	1:4	52/55	

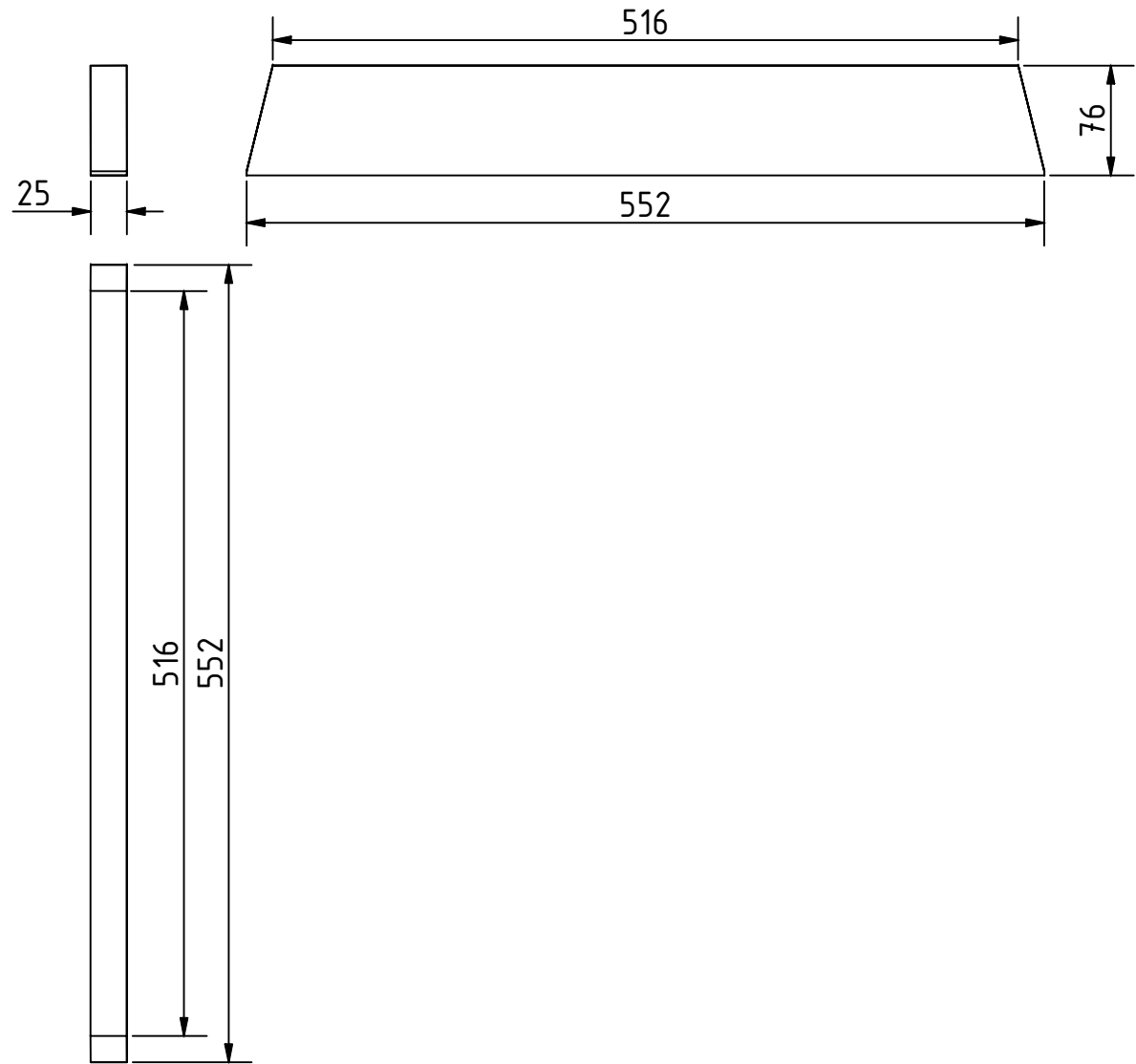
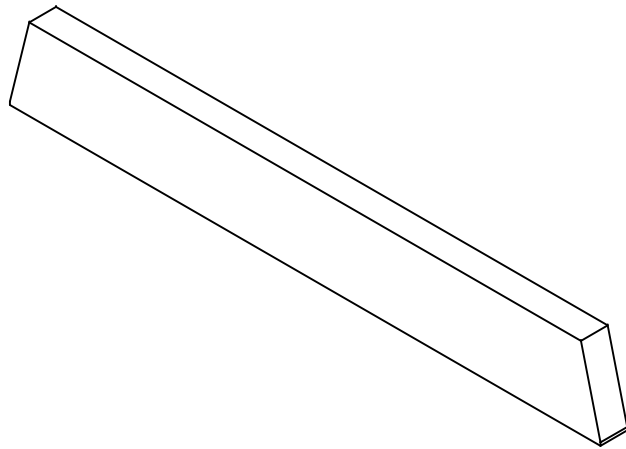

Note: All units in mm.

PROJECT	CREATED BY	APPROVED BY	DATE	VERSION
Bandsaw wheel - Dia 12 inch	E. Araujo	A. Morillo	13/09/2021	1.0
PART NAME	FILE NAME			POS
Strips 3	jah_bsw_bandsaw_wheel_-_dia_12_inch.dwg			6.5
PUBLISHED BY	DOC. TYPE	MATERIAL	QUANTITY	
 OPEN HARDWARE OBSERVATORY Free Blueprints for Sustainable Development OHO e.V.	Part	Plywood	2	
	LICENCE	SCALE	SHEET	
	CC-BY-SA 4.0	1:4	53/55	

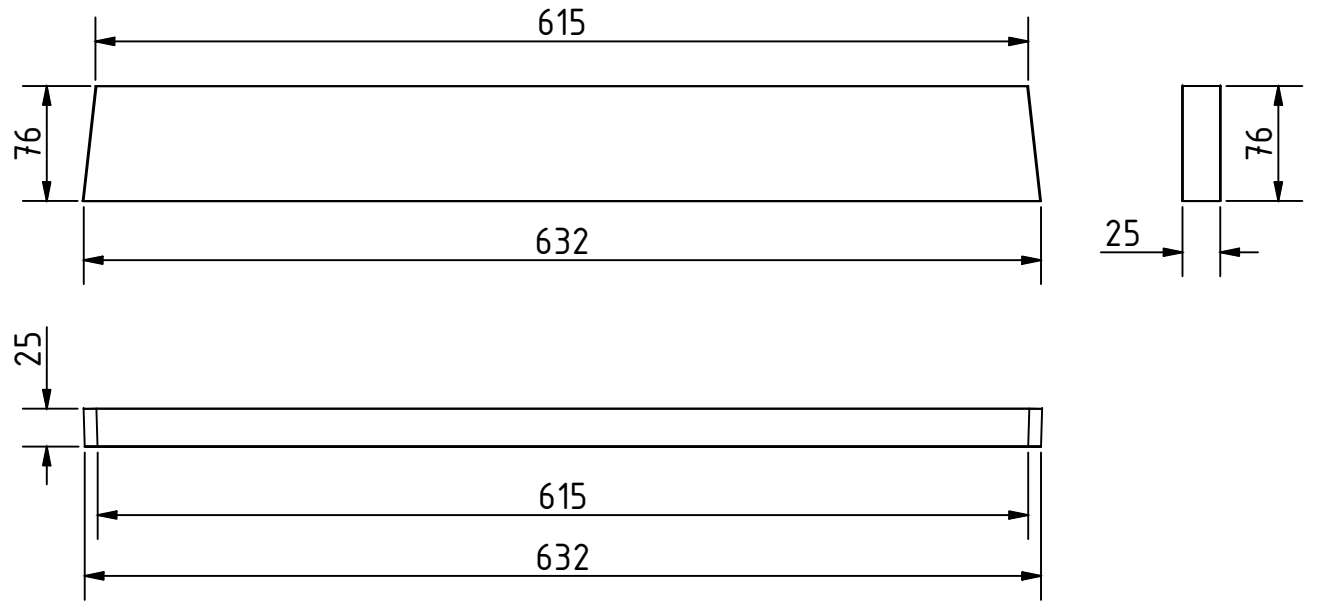
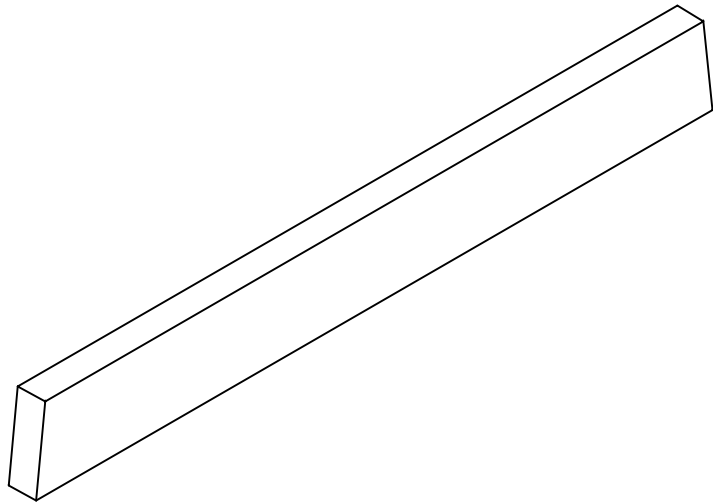

Note: All units in mm.

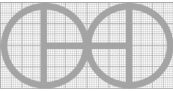
PROJECT	CREATED BY	APPROVED BY	DATE	VERSION
Bandsaw wheel - Dia 12 inch	E. Araujo	A. Morillo	13/09/2021	1.0
PART NAME	FILE NAME			POS
Strips 4	jah_bsw_bandsaw_wheel_-_dia_12_inch.dwg			6.6
PUBLISHED BY	DOC. TYPE	MATERIAL	QUANTITY	
 OPEN HARDWARE OBSERVATORY Free Blueprints for Sustainable Development OHO e.V.	Part	Plywood	2	
	LICENCE	SCALE	SHEET	
	CC-BY-SA 4.0	1:4	54/55	

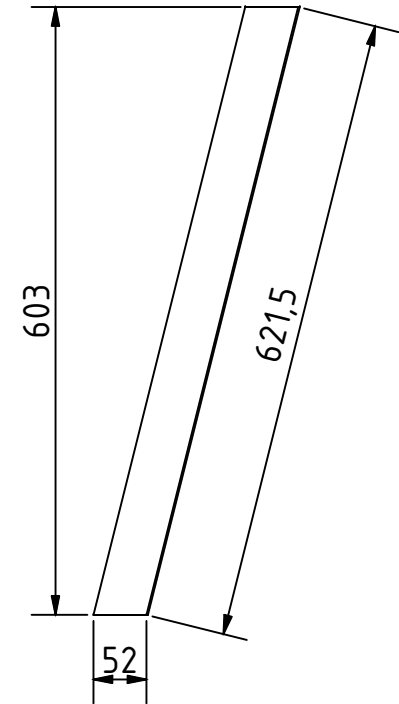
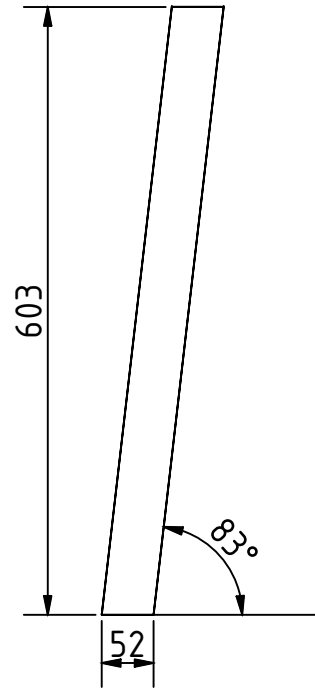
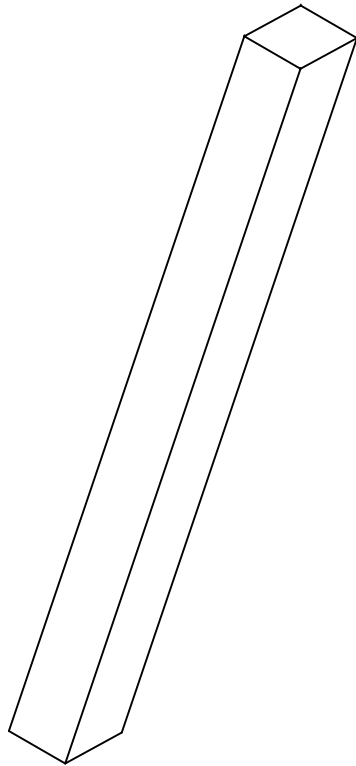

Note: All units in mm.

PROJECT	CREATED BY	APPROVED BY	DATE	VERSION
Bandsaw wheel - Dia 12 inch	E. Araujo	A. Morillo	13/09/2021	1.0
PART NAME	FILE NAME			POS
Legs	jah_bsw_bandsaw_wheel_-_dia_12_inch.dwg			6.7
PUBLISHED BY	DOC. TYPE	MATERIAL		QUANTITY
 OPEN HARDWARE OBSERVATORY Free Blueprints for Sustainable Development OHO e.V.	Part	Plywood		4
	LICENCE		SCALE	SHEET
	CC-BY-SA 4.0		1:7.5	55/55