

ELEVATION (1 : 50)

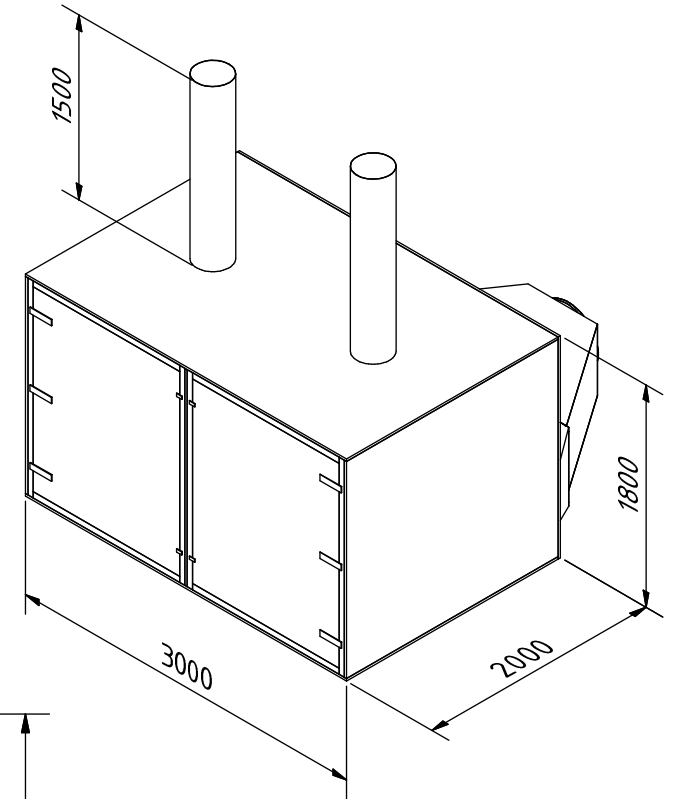

A-A (1 : 50)

B-B (1 : 30)

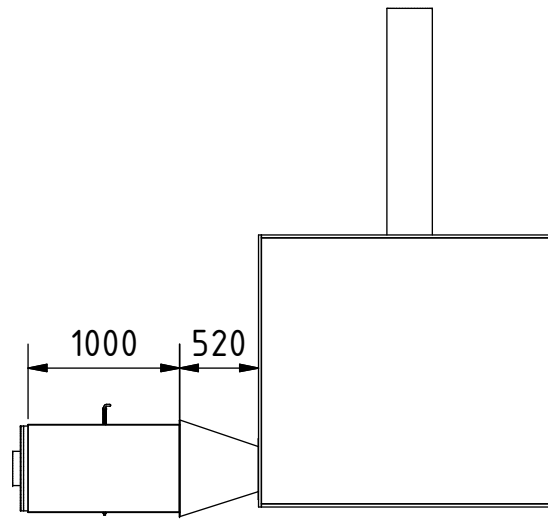
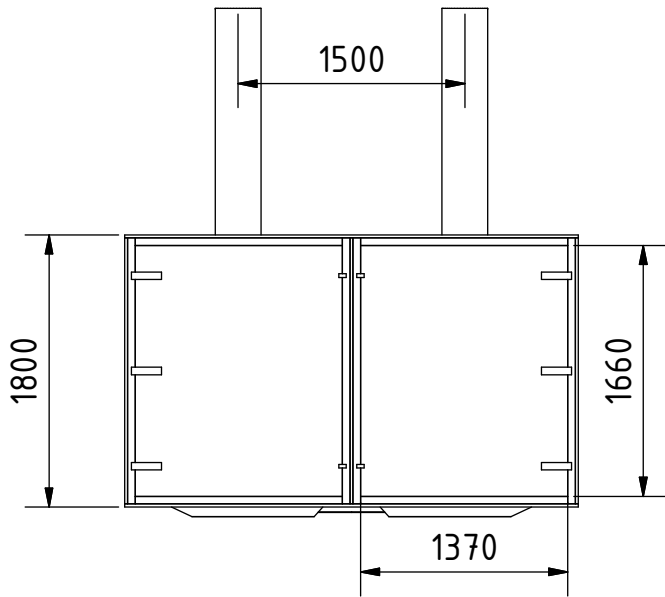
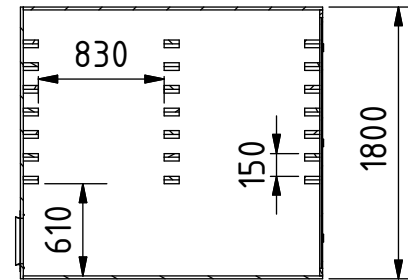
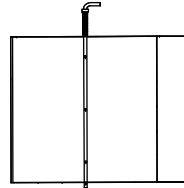
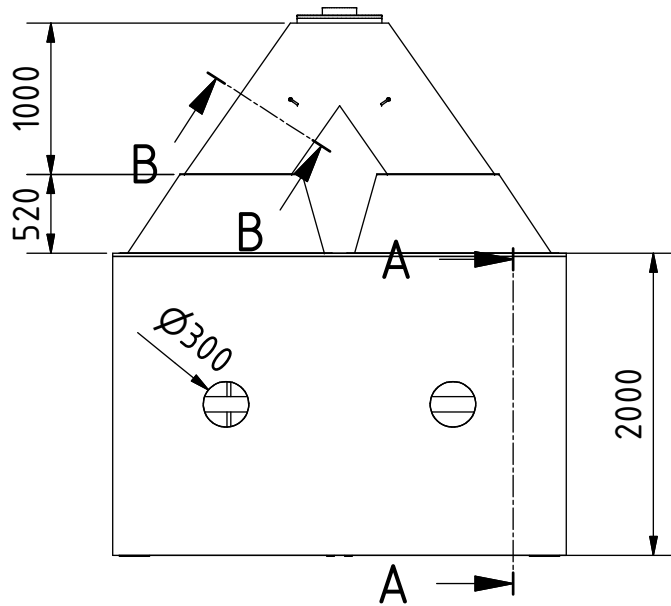

Hinweis: Alle einheiten in mm.

PROJEKT Batch Tray Dryer fuer Lebensmittel	ERSTELLT VON J. Zeron	GENEHMIGT VON A. Morillo	DATE 10/08/2021	VERSION 1.0
TEIL-NAME 3d-Ansichten	DATEI-NAME pac_btd_batch-tray-dryer.iam			TEIL-CODE A1
ENTWICKELT VON Practical Action	UMGESTALTET VON OHO e.V.	DOK. TYP Assembly	WERKSTOFF	MENGE -
		LIZENZ CC-BY-SA 4.0	SCALE 1:50	SEITE 1 / 28

EXPLOSION (1 : 40)

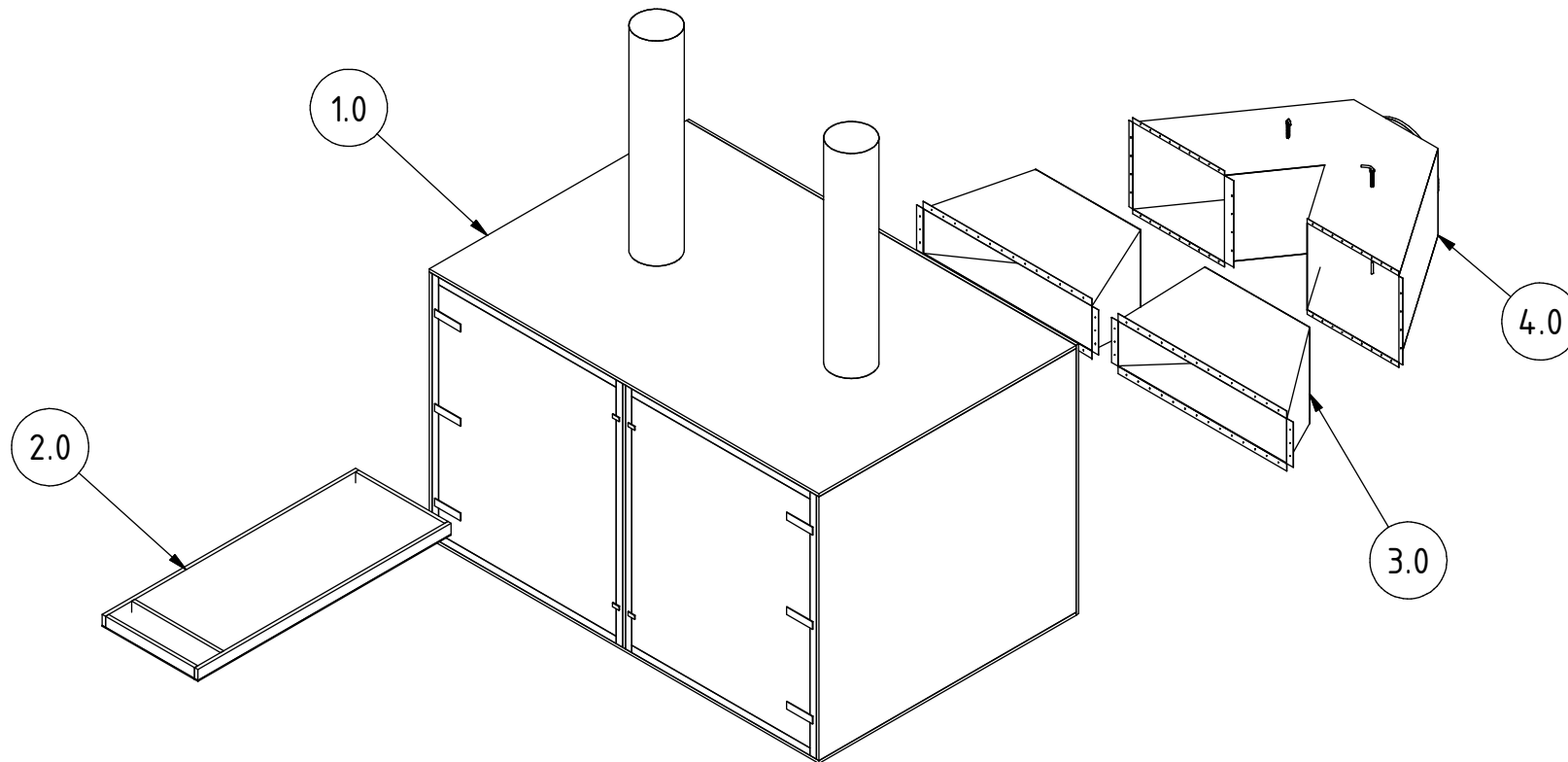

PROJEKT Batch Tray Dryer fuer Lebensmittel		ERSTELLT VON J. Zeron	GENEHMIGT VON A. Morillo	DATE 10/08/2021	VERSION 1.0
TEIL-NAME 3d-Explosionszeichnungen		DATEI-NAME pac_btd_batch-tray-dryer.ipn			TEIL-CODE A2
ENTWICKELT VON Practical Action	UMGESTALTET VON OHO e.V.	DOK. TYP Assembly	WERKSTOFF	MENGE -	SEITE 2 / 28
		LIZENZ CC-BY-SA 4.0	SCALE 1:40		

Parts list

POS	QTY	TEIL NAME	DATEI-NAME	TEIL-TYP	SPEZIFIKATIONEN	SEITE
A1	-	3d-Ansichten	pac_btd_batch-tray-dryer.iam	-	-	1
A2	-	3d-Explosionszeichnungen	pac_btd_batch-tray-dryer.ipn	-	-	2
B1	-	Teileliste	pac_btd_batch-tray-dryer.csv	-	-	3-4
1.0	-	Kabinett	Cabinet.ipn	-	-	5
1.1	1	Schrank unter	Cabinet under.ipt	Production	Hartholz 20mm	6
1.2	1	Schrankruckseite	Cabinet back.ipt	Production	Hartholz 20mm	7
1.3	2	Schrankseite	Cabinet side.ipt	Production	Hartholz 20mm	8
1.4	1	Schrankinnenraum	Cabinet inner.ipt	Production	Hartholz 20mm	9
1.5	1	Schrankoberseite	Cabinet top.ipt	Production	Hartholz 20mm	10
1.6	84	Regaltrager A	-	Production	Hartholz 25x25x100 mm	-
1.7	42	Regaltrager B	-	Production	Hartholz 25x100x1470 mm	-
1.8	4	Schrankfront A	-	Production	Hartholz 20x50x1760 mm	-
1.9	4	Schrankfront B	-	Production	Hartholz 20x50x1370 mm	-
1.10	2	Turplatte	Door plate.ipt	Production	Hartholz 10mm	11
1.11	6	Scharnier	-	Buy	Scharnier edelstahl 72x10mm	-
1.12	4	Verriegeln	-	Buy	Verschluss edelstahl 15mm	-
1.13	2	Luft raus	-	Production	18G 1mm weichstahlplatte D 300mm L=1500 mm	-
1.14	-	Join A	-	Standard	DIN 97 flachkopfschraube 3.5x100mm	-
2.0	-	Tablett	Tray.ipn	-	-	12
2.1	2	Tablettrahmen A	-	Production	Nadeholz 25x80x1950 mm	-
2.2	3	Tablettrahmen B	-	Production	Nadeholz 25x80x685 mm	-
2.3	1	Maschendraht	-	Buy	Huhnerdraht	-
2.4	-	Beitreten B	-	Standard	DIN 97 flachkopfschraube 3.5x50mm	-
3.0	-	Lufteinlass	Air inlet.ipn	-	-	13
3.1	4	Deck-unter platte	Top-under plate.ipt	Production	18G 1mm weichstahlplatte	14
3.2	2	Beilagenteller A	Side plate A.ipt	Production	18G 1mm weichstahlplatte	15
3.3	2	Beilagenteller B	Side plate B.ipt	Production	18G 1mm weichstahlplatte	16
3.4	76	Beitreten C	-	Standard	DIN 97 flachkopfschraube 8.5x16mm	-
3.5	48	Beitreten D	-	Standard	DIN 931 6x8mm - sechskantschraube (mit mutter)	-

PROJEKT Batch Tray Dryer fuer Lebensmittel		ERSTELLT VON J. Zeron		GENEHMIGT VON A. Morillo		DATE 10/08/2021		VERSION 1.0	
TEIL-NAME Teileliste		DATEI-NAME pac_btd_batch-tray-dryer.csv						TEIL-CODE B1	
ENTWICKELT VON Practical Action		UMGESTALTET VON  OHO e.V.		DOK. TYP Parts list		WERKSTOFF		MENGE -	
				LIZENZ CC-BY-SA 4.0		SCALE		SEITE 3 /28	

Parts list

POS	QTY	TEIL NAME	DATEI-NAME	TEIL-TYP	SPEZIFIKATIONEN	SEITE
4.0	-	Luftdampfer	Air damper.ipn	-	-	17
4.1	2	Deckplatte	Top plate.ipt	Production	18G 1mm weichstahlplatte	18
4.2	2	Seitenplatte A	Side plate A.ipt	Production	18G 1mm weichstahlplatte	19
4.3	2	Seitenplatte B	Side plate B.ipt	Production	18G 1mm weichstahlplatte	20
4.4	1	Ruckplatte	Back plate.ipt	Production	18G 1mm weichstahlplatte	21
4.5	1	Anschlussmuffe	Connection sleve.ipt	Production	18G 1mm weichstahlplatte	22
4.6	1	Adapter A.1	Adaptor A.1.ipt	Production	18G 1mm weichstahlplatte	23
4.7	1	Adapter A.2	Adaptor A.2.ipt	Production	18G 1mm weichstahlplatte	24
4.8	1	Adapter B	Adaptor B.ipt	Production	18G 1mm weichstahlplatte	25
4.9	2	Dampferplatte	Damper plate.ipt	Production	18G 1mm weichstahlplatte	26
4.10	2	Dampferstange	Damper bar.ipt	Production	Stahl A36 12mm	27
4.11	2	Dampferstopp	Damper stop.ipt	Production	Stahl A36 25mm	28
4.12	2	Dampferfeder	-	Buy	Federstahl, d20mm, w40N, Lw 100mm, L 120mm	-
4.13	8	Dampferstift	-	Buy	Stahl A36 stift 6mm	-

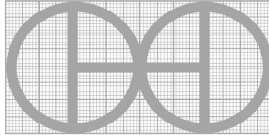
PROJEKT Batch Tray Dryer fuer Lebensmittel		ERSTELLT VON J. Zeron		GENEHMIGT VON A. Morillo		DATE 10/08/2021		VERSION 1.0	
TEIL-NAME Teileliste			DATEI-NAME pac_btd_batch-tray-dryer.csv					TEIL-CODE B1	
ENTWICKELT VON Practical Action		UMGESTALTET VON  OHO e.V.		DOK. TYP Parts list		WERKSTOFF		MENGE -	
				LIZENZ CC-BY-SA 4.0		SCALE		SEITE 4 /28	

EXPLOSION (1 : 50)

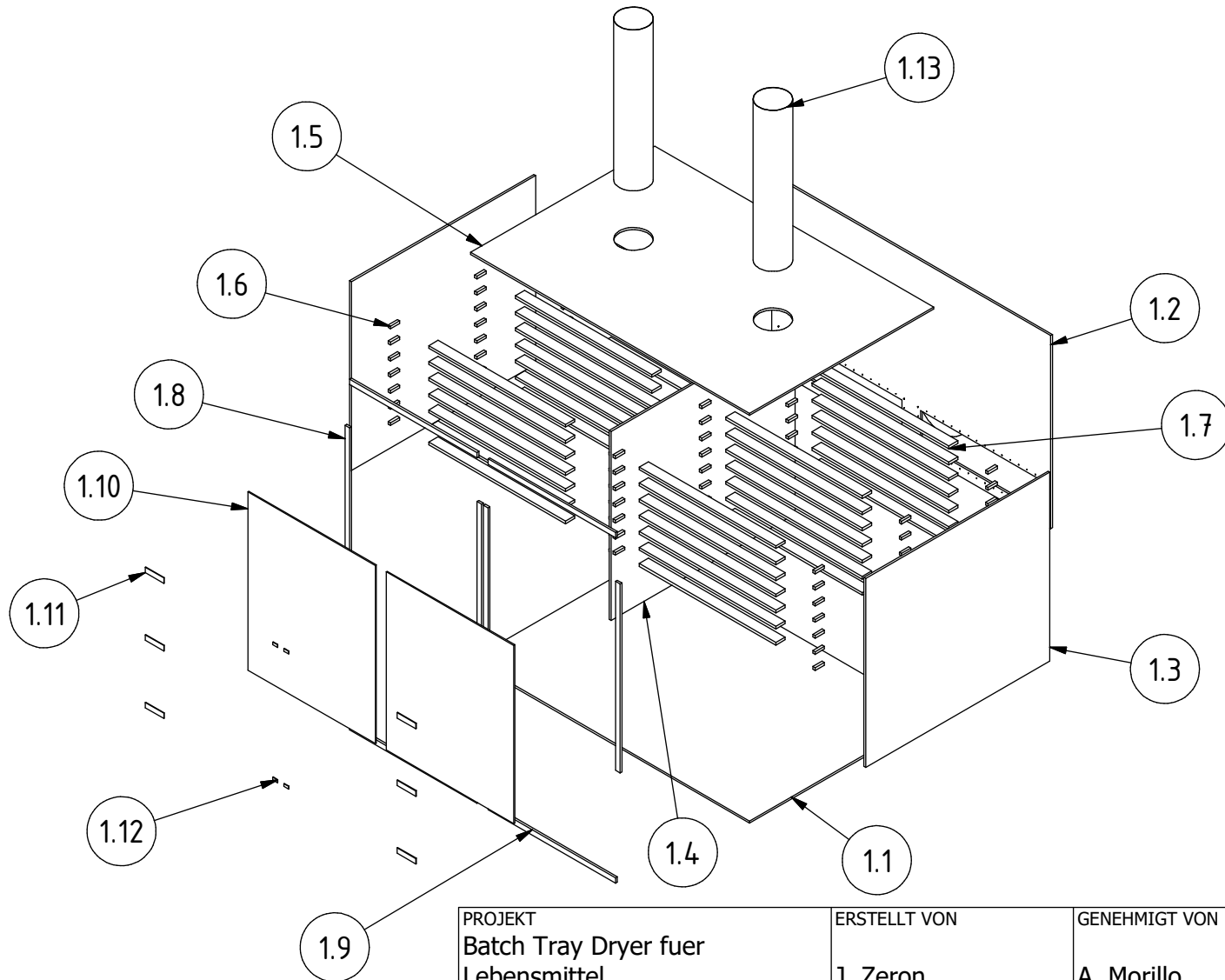

PROJEKT Batch Tray Dryer fuer Lebensmittel		ERSTELLT VON J. Zeron		GENEHMIGT VON A. Morillo		DATE 10/08/2021		VERSION 1.0	
TEIL-NAME Kabinett		DATEI-NAME Cabinet.ipn						TEIL-CODE 1.0	
ENTWICKELT VON Practical Action		UMGESTALTET VON OHO e.V.		DOK. TYP Assembly		WERKSTOFF		MENGE -	
				LIZENZ CC-BY-SA 4.0		SCALE 1:50		SEITE 5 /28	

PLAN (1 : 30)

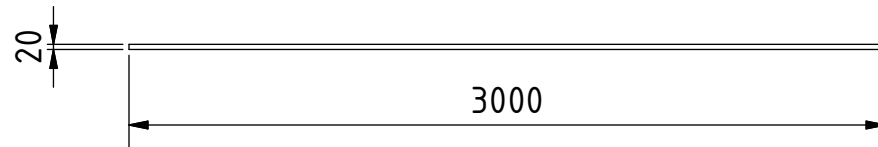
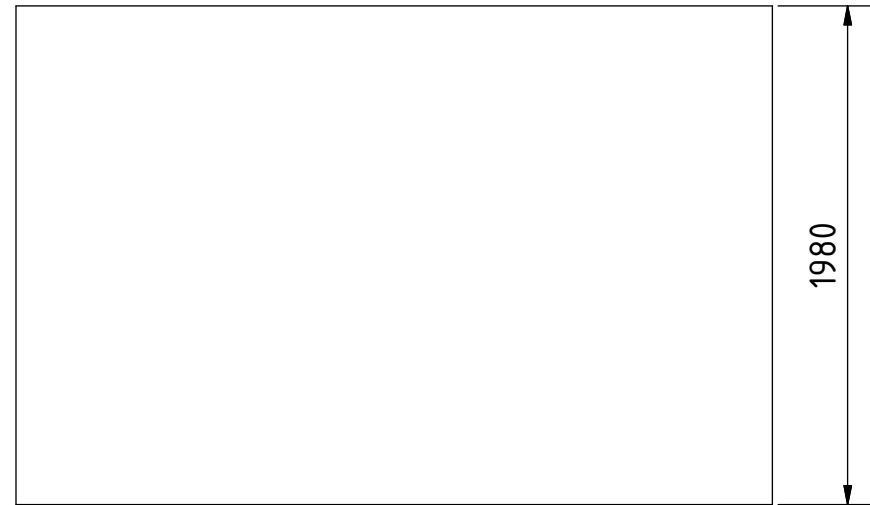
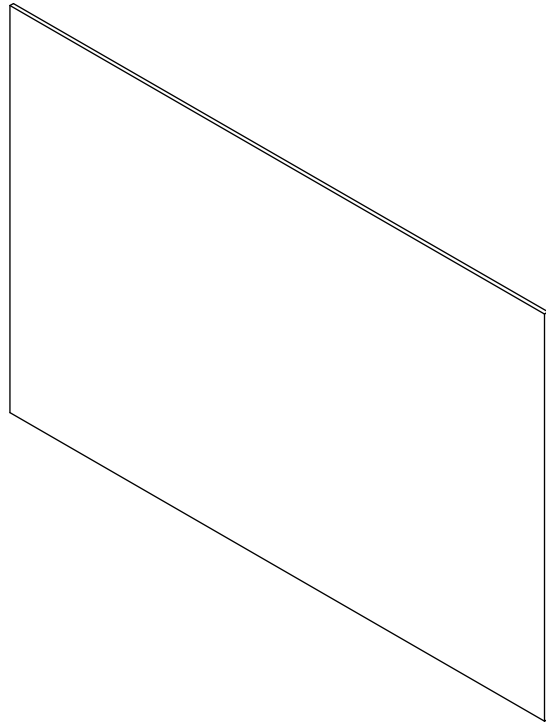

Hinweis: Alle einheiten in mm.

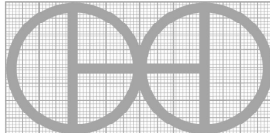
PROJEKT Batch Tray Dryer fuer Lebensmittel	ERSTELLT VON J. Zeron	GENEHMIGT VON A. Morillo	DATE 10/08/2021	VERSION 1.0
TEIL-NAME Schrank unter	DATEI-NAME Cabinet under.ipt			TEIL-CODE 1.1
ENTWICKELT VON	UMGESTALTET VON 	DOK. TYP Part	WERKSTOFF Hartholz	MENGE 1
Practical Action	OHO e.V.	LIZENZ CC-BY-SA 4.0	SCALE 1:30	SEITE 6 /28

ELEVATION (1 : 35)

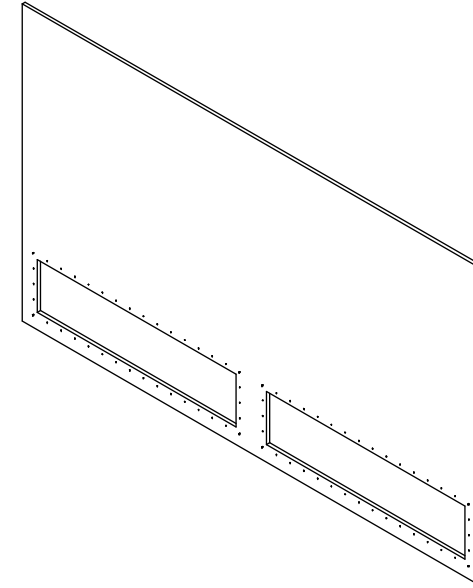
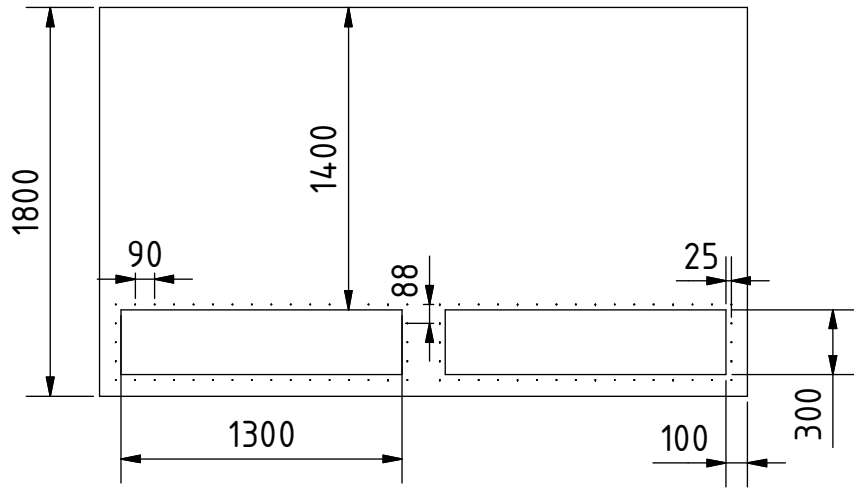

Hinweis: Alle einheiten in mm.

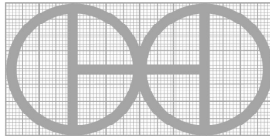
PROJEKT Batch Tray Dryer fuer Lebensmittel	ERSTELLT VON J. Zeron	GENEHMIGT VON A. Morillo	DATE 10/08/2021	VERSION 1.0
TEIL-NAME Schrankruckseite	DATEI-NAME Cabinet back.ipt			TEIL-CODE 1.2
ENTWICKELT VON	UMGESTALTET VON 	DOK. TYP Part	WERKSTOFF Hartholz	MENGE 1
Practical Action	OHO e.V.	LIZENZ CC-BY-SA 4.0	SCALE 1:35	SEITE 7 /28

ELEVATION (1 : 25)

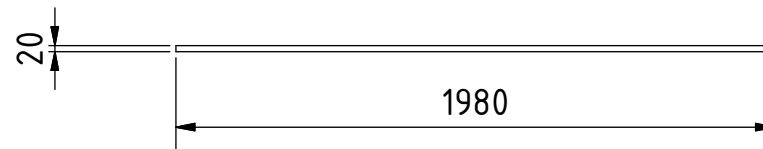
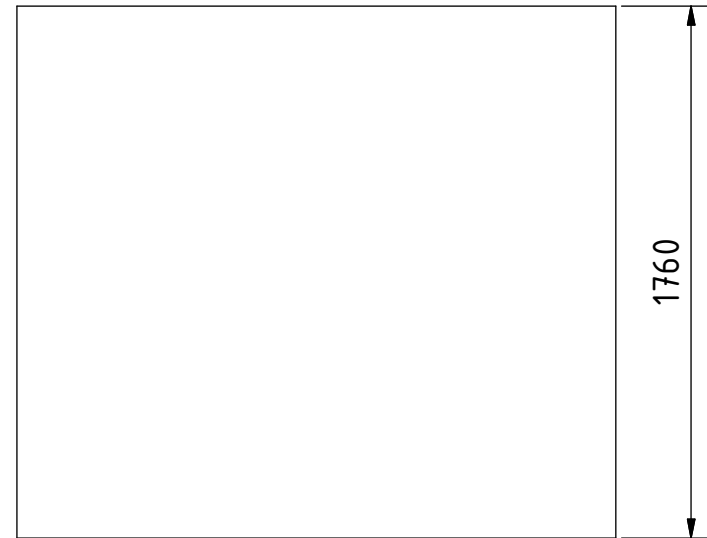
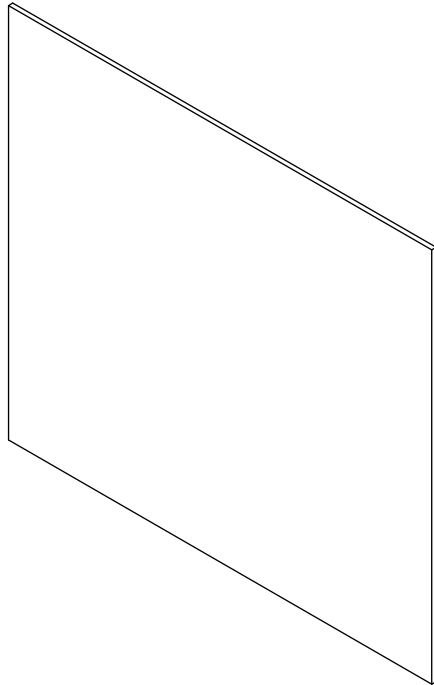

Hinweis: Alle einheiten in mm.

PROJEKT Batch Tray Dryer fuer Lebensmittel		ERSTELLT VON J. Zeron	GENEHMIGT VON A. Morillo	DATE 10/08/2021	VERSION 1.0
TEIL-NAME Schrankseite		DATEI-NAME Cabinet side.ipt			TEIL-CODE 1.3
ENTWICKELT VON	UMGESTALTET VON	DOK. TYP	WERKSTOFF	MENGE	
Practical Action	OHO e.V.	Part	Hartholz	2	
		LIZENZ	SCALE	SEITE	
		CC-BY-SA 4.0	1:25	8 /28	



ELEVATION (1 : 25)

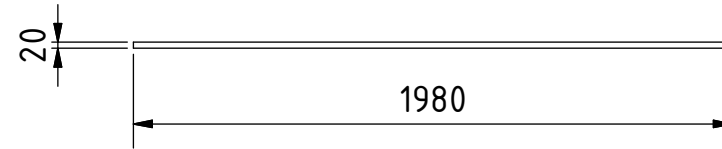
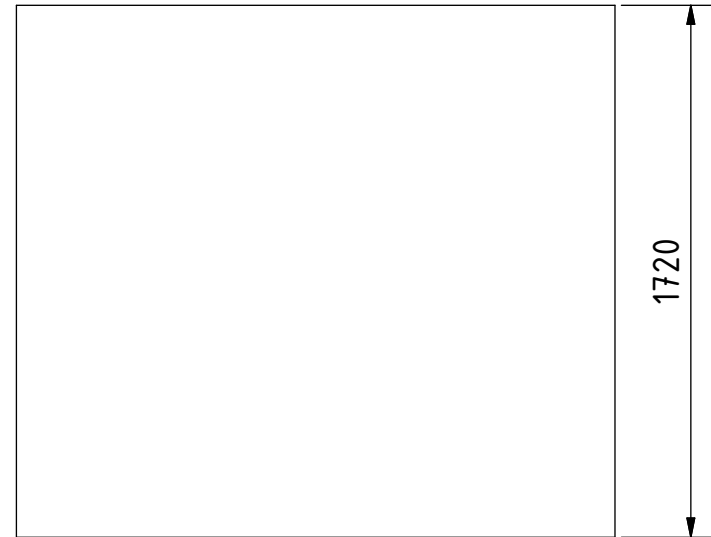
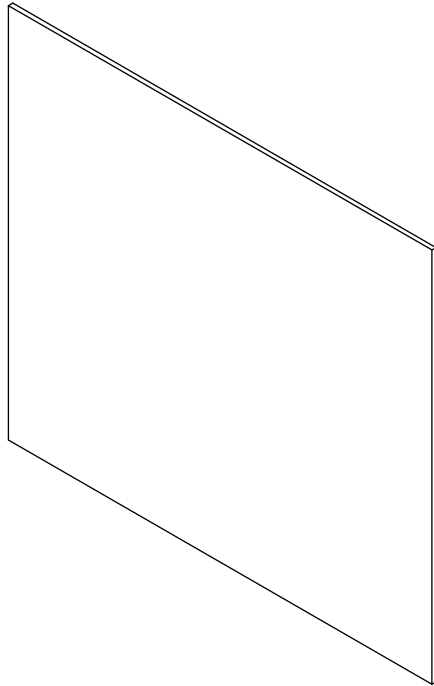

Hinweis: Alle einheiten in mm.

PROJEKT Batch Tray Dryer fuer Lebensmittel	ERSTELLT VON J. Zeron	GENEHMIGT VON A. Morillo	DATE 10/08/2021	VERSION 1.0
TEIL-NAME Schrankinnenraum	DATEI-NAME Cabinet inner.ipt			TEIL-CODE 1.4
ENTWICKELT VON Practical Action	UMGESTALTET VON OHO e.V.	DOK. TYP Part	WERKSTOFF Hartholz	MENGE 1
		LIZENZ CC-BY-SA 4.0	SCALE 1:25	SEITE 9 /28

PLAN (1 : 35)

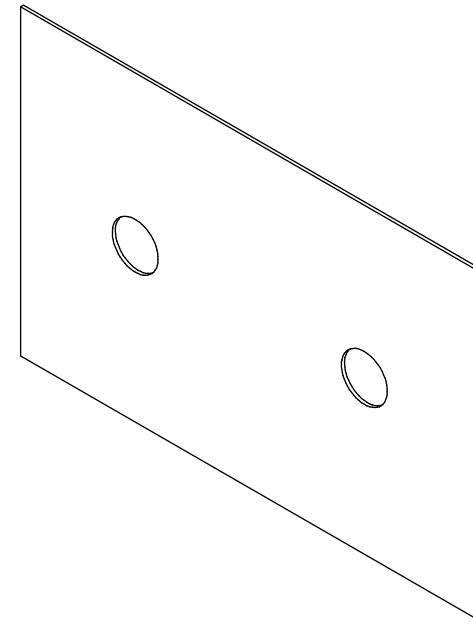
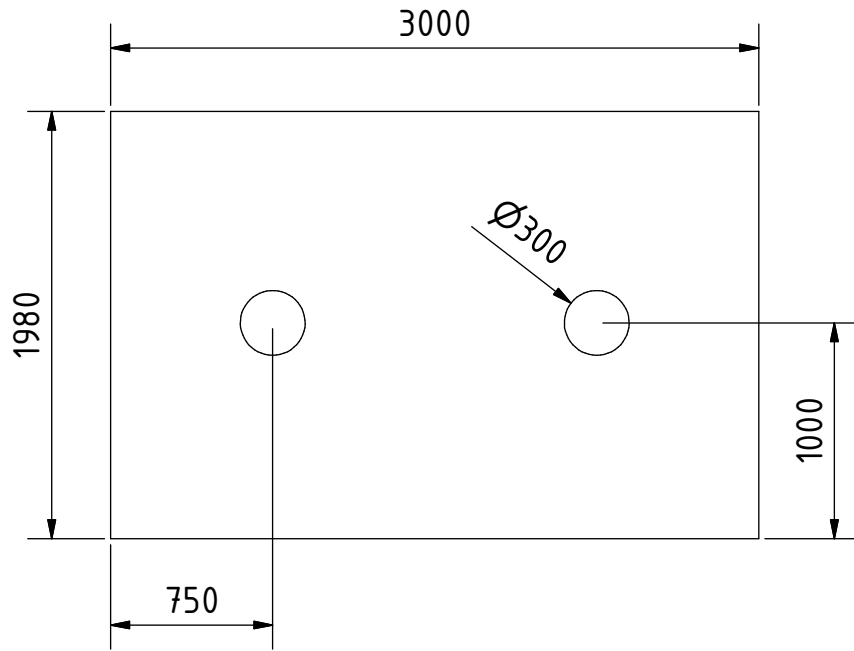

Hinweis: Alle einheiten in mm.

PROJEKT Batch Tray Dryer fuer Lebensmittel	ERSTELLT VON J. Zeron	GENEHMIGT VON A. Morillo	DATE 10/08/2021	VERSION 1.0
TEIL-NAME Schrankoberseite	DATEI-NAME Cabinet top.ipt			TEIL-CODE 1.5
ENTWICKELT VON Practical Action	UMGESTALTET VON OHO e.V.	DOK. TYP Part	WERKSTOFF Hartholz	MENGE 1
		LIZENZ CC-BY-SA 4.0	SCALE 1:35	SEITE 10 /28

ELEVATION (1 : 20)

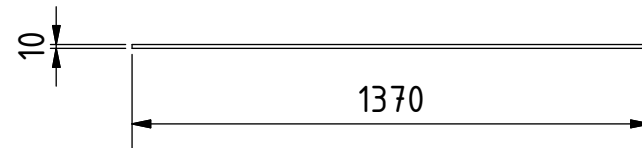
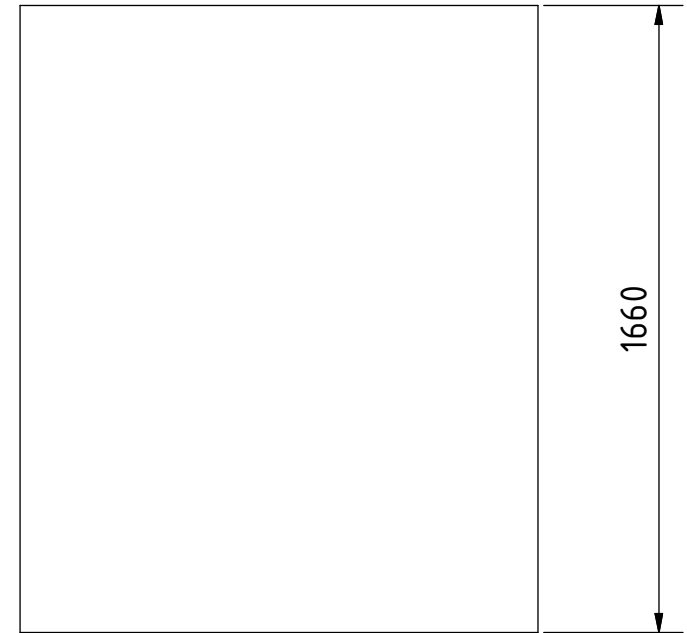
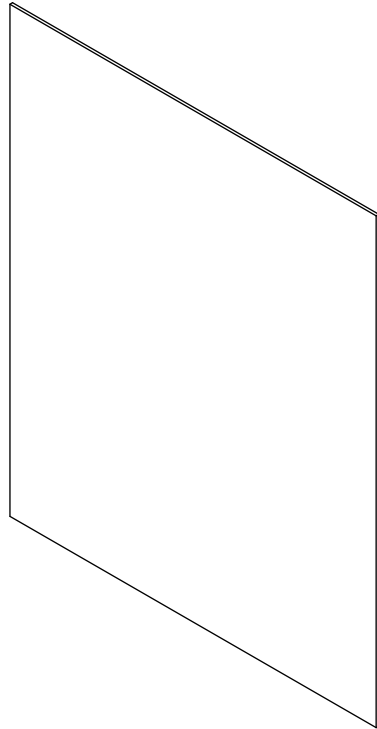

Hinweis: Alle einheiten in mm.

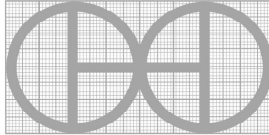
PROJEKT Batch Tray Dryer fuer Lebensmittel	ERSTELLT VON J. Zeron	GENEHMIGT VON A. Morillo	DATE 10/08/2021	VERSION 1.0
TEIL-NAME Turplatte	DATEI-NAME Door plate.ipt			TEIL-CODE 1.10
ENTWICKELT VON	UMGESTALTET VON 	DOK. TYP Part	WERKSTOFF Hartholz	MENGE 2
Practical Action	OHO e.V.	LIZENZ CC-BY-SA 4.0	SCALE 1:20	SEITE 11 /28

EXPLOSION (1 : 20)

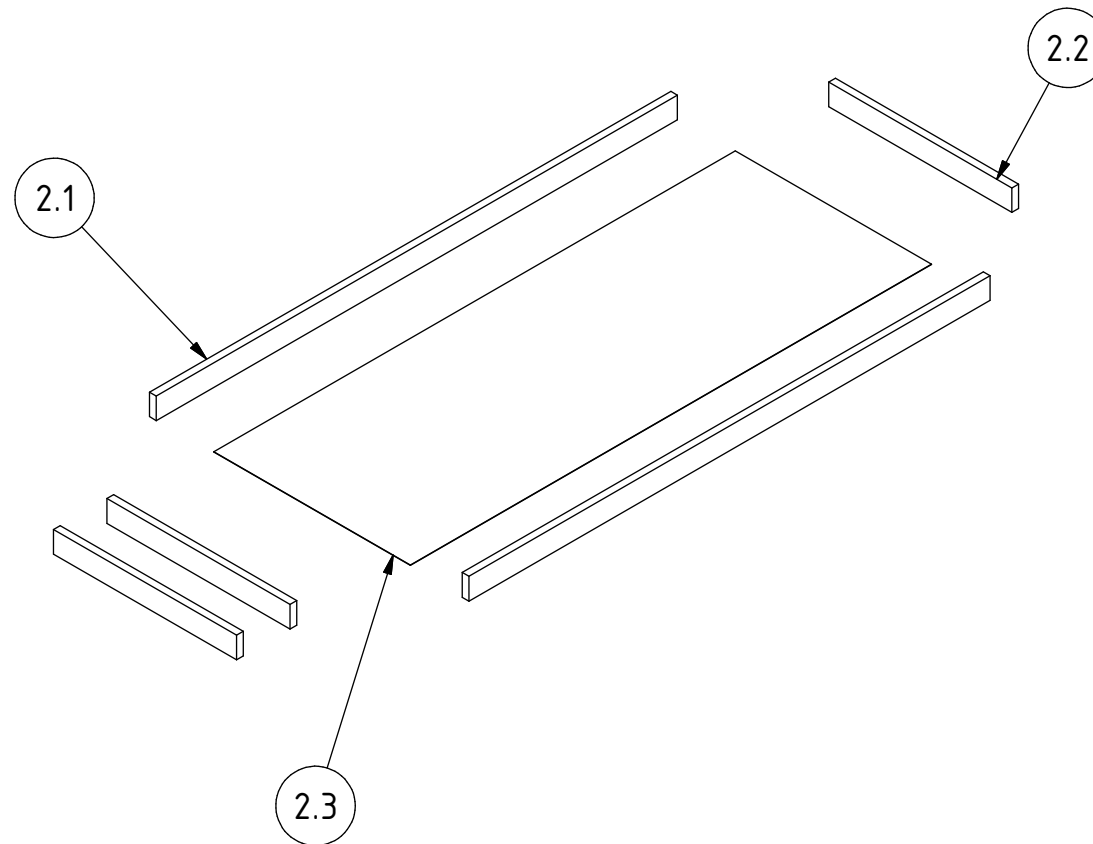

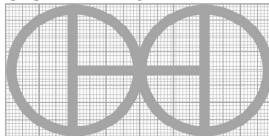
PROJEKT Batch Tray Dryer fuer Lebensmittel	ERSTELLT VON J. Zeron	GENEHMIGT VON A. Morillo	DATE 10/08/2021	VERSION 1.0
TEIL-NAME Tablett	DATEI-NAME Tray.ipn			TEIL-CODE 2.0
ENTWICKELT VON Practical Action	UMGESTALTET VON OHO e.V.	DOK. TYP Assembly	WERKSTOFF	MENGE -
		LIZENZ CC-BY-SA 4.0	SCALE 1:20	SEITE 12 /28

EXPLOSION (1 : 25)

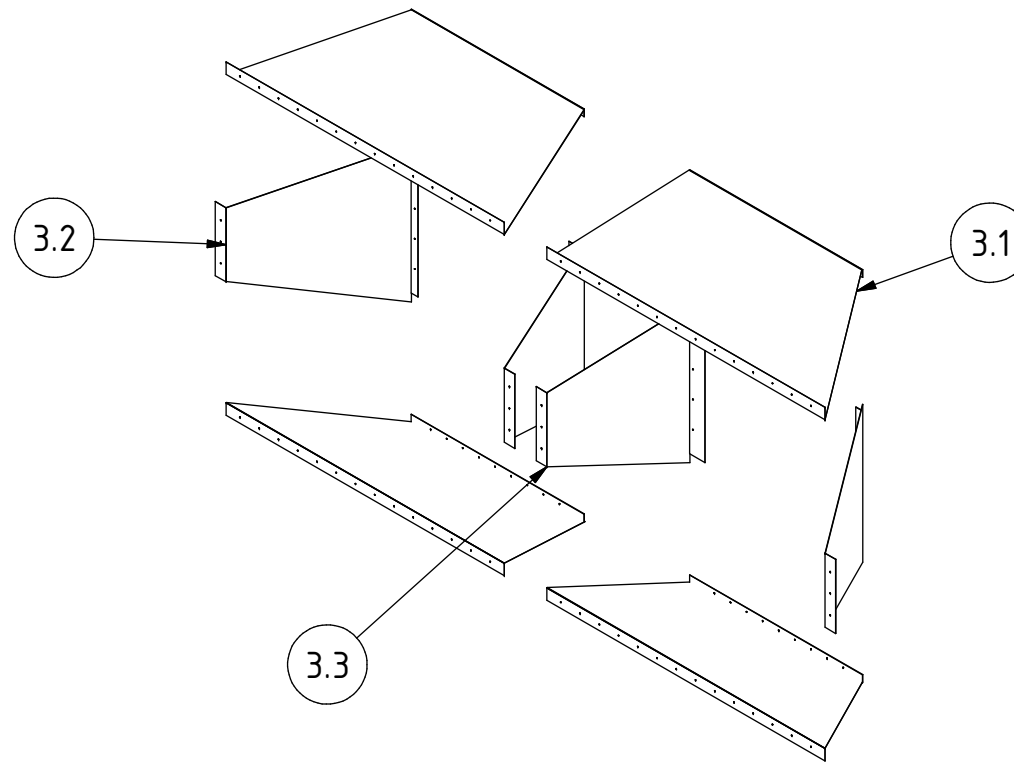

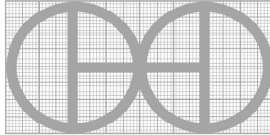
PROJEKT Batch Tray Dryer fuer Lebensmittel		ERSTELLT VON J. Zeron	GENEHMIGT VON A. Morillo	DATE 10/08/2021	VERSION 1.0
TEIL-NAME Lufteinlass		DATEI-NAME Air inlet.ipn			TEIL-CODE 3.0
ENTWICKELT VON	UMGESTALTET VON	DOK. TYP	WERKSTOFF	MENGE	
		Assembly		-	
Practical Action	OHO e.V.	LIZENZ CC-BY-SA 4.0	SCALE 1:25	SEITE 13 /28	

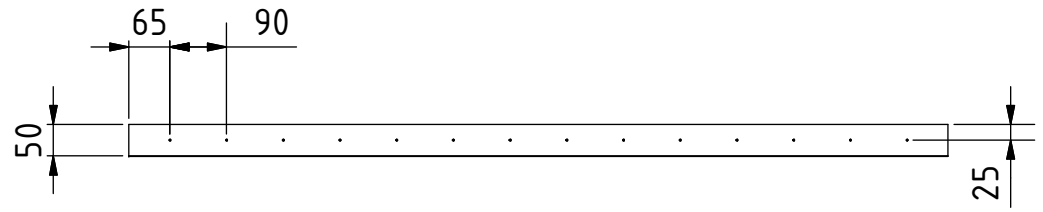

PLAN (1 : 12)

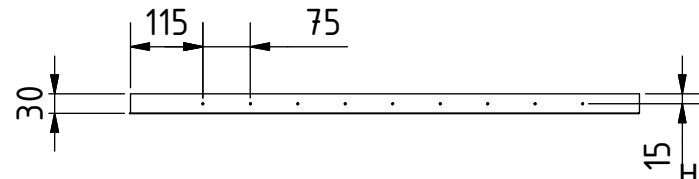
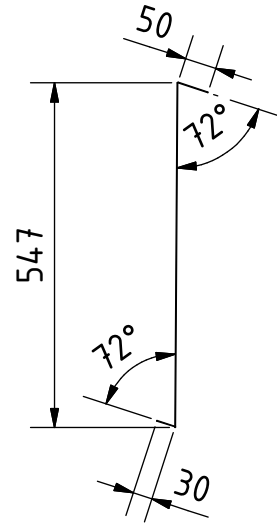
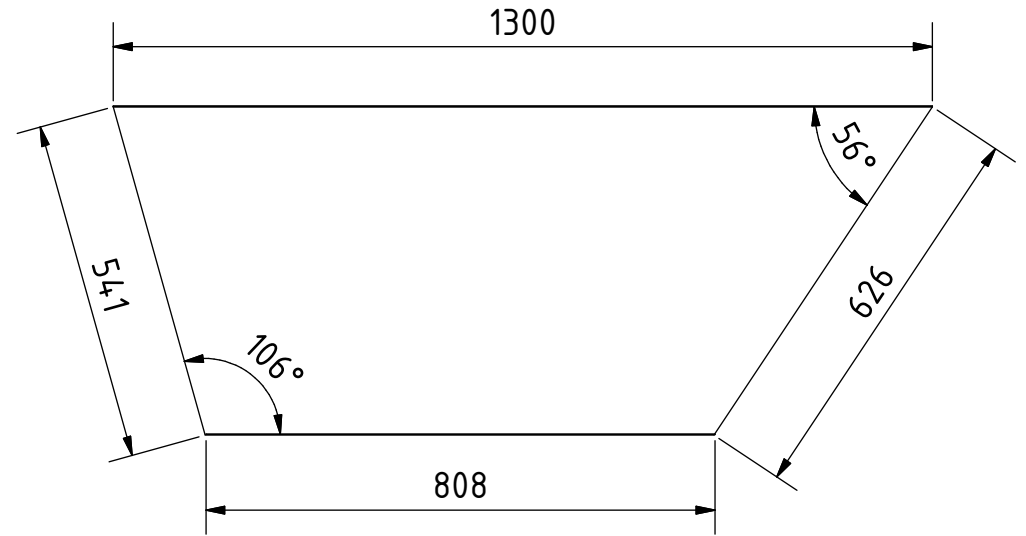

Hinweis: Alle einheiten in mm.

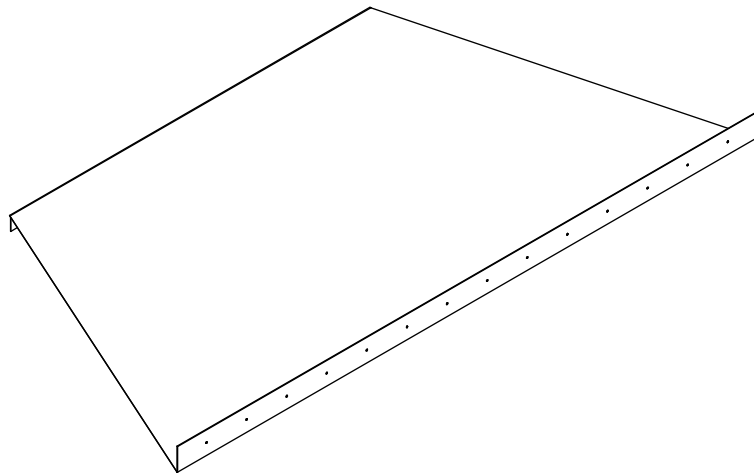

PROJEKT Batch Tray Dryer fuer Lebensmittel	ERSTELLT VON J. Zeron	GENEHMIGT VON A. Morillo	DATE 10/08/2021	VERSION 1.0
TEIL-NAME Deck-unter platte	DATEI-NAME Top-under plate.ipt			TEIL-CODE 3.1
ENTWICKELT VON Practical Action	UMGESTALTET VON OHO e.V.	DOK. TYP Part	WERKSTOFF 18G weichstahlplatte	MENGE 4
		LIZENZ CC-BY-SA 4.0	SCALE 1:12	SEITE 14 /28

ELEVATION (1 : 10)

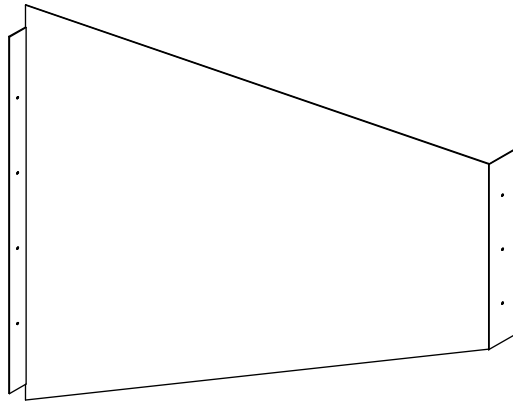
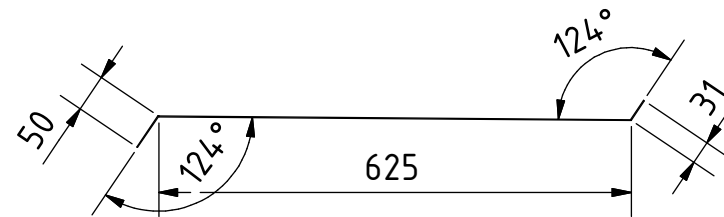
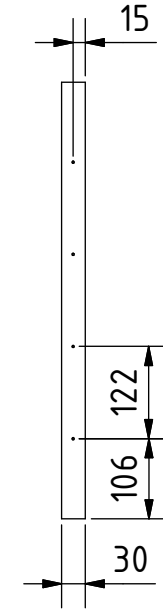
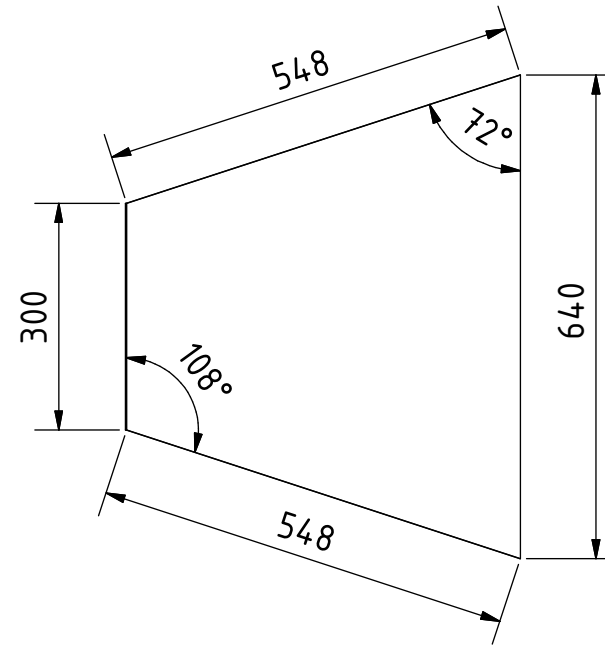
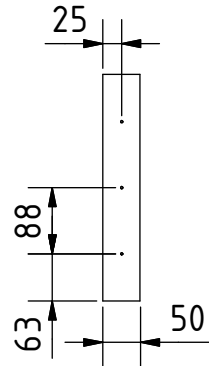

Hinweis: Alle einheiten in mm.

PROJEKT Batch Tray Dryer fuer Lebensmittel	ERSTELLT VON J. Zeron	GENEHMIGT VON A. Morillo	DATE 10/08/2021	VERSION 1.0
TEIL-NAME Beilagenteller A	DATEI-NAME Side plate A.ipt			TEIL-CODE 3.2
ENTWICKELT VON Practical Action	UMGESTALTET VON OHO e.V.	DOK. TYP Part	WERKSTOFF 18G weichstahlplatte	MENGE 2
		LIZENZ CC-BY-SA 4.0	SCALE 1:10	SEITE 15 /28

ELEVATION (1 : 10)

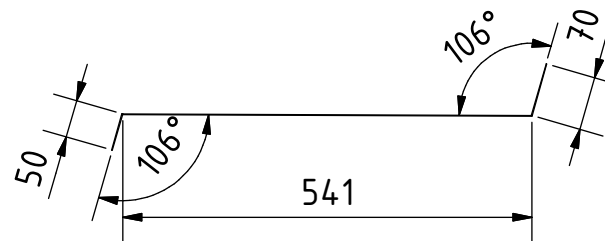
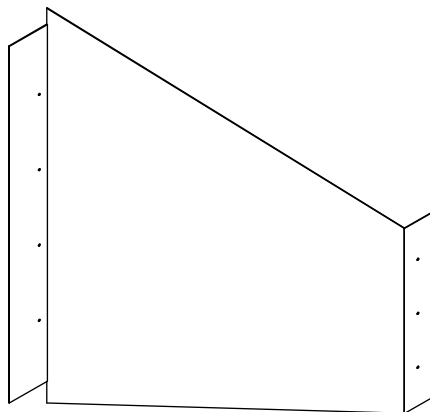
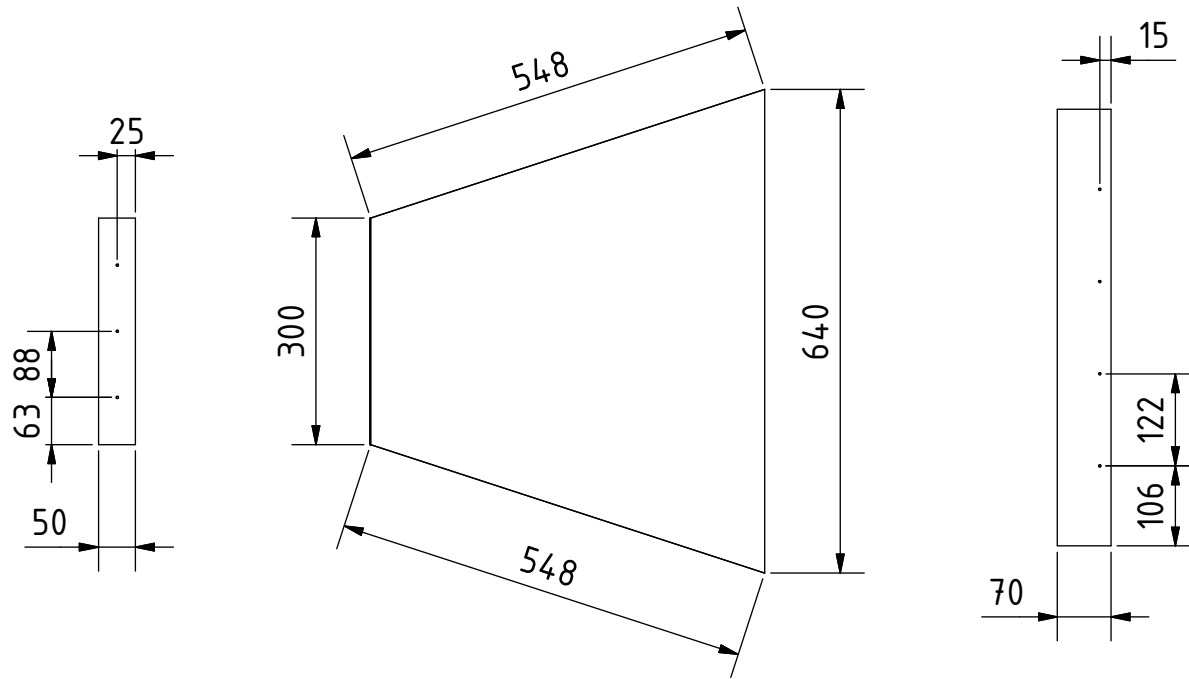

Hinweis: Alle einheiten in mm.

PROJEKT Batch Tray Dryer fuer Lebensmittel	ERSTELLT VON J. Zeron	GENEHMIGT VON A. Morillo	DATE 10/08/2021	VERSION 1.0
TEIL-NAME Beilagenteller B	DATEI-NAME Side plate B.ipt			TEIL-CODE 3.3
ENTWICKELT VON Practical Action	UMGESTALTET VON OHO e.V.	DOK. TYP Part	WERKSTOFF 18G weichstahlplatte	MENGE 2
		LIZENZ CC-BY-SA 4.0	SCALE 1:10	SEITE 16 /28

EXPLOSION (1 : 25)

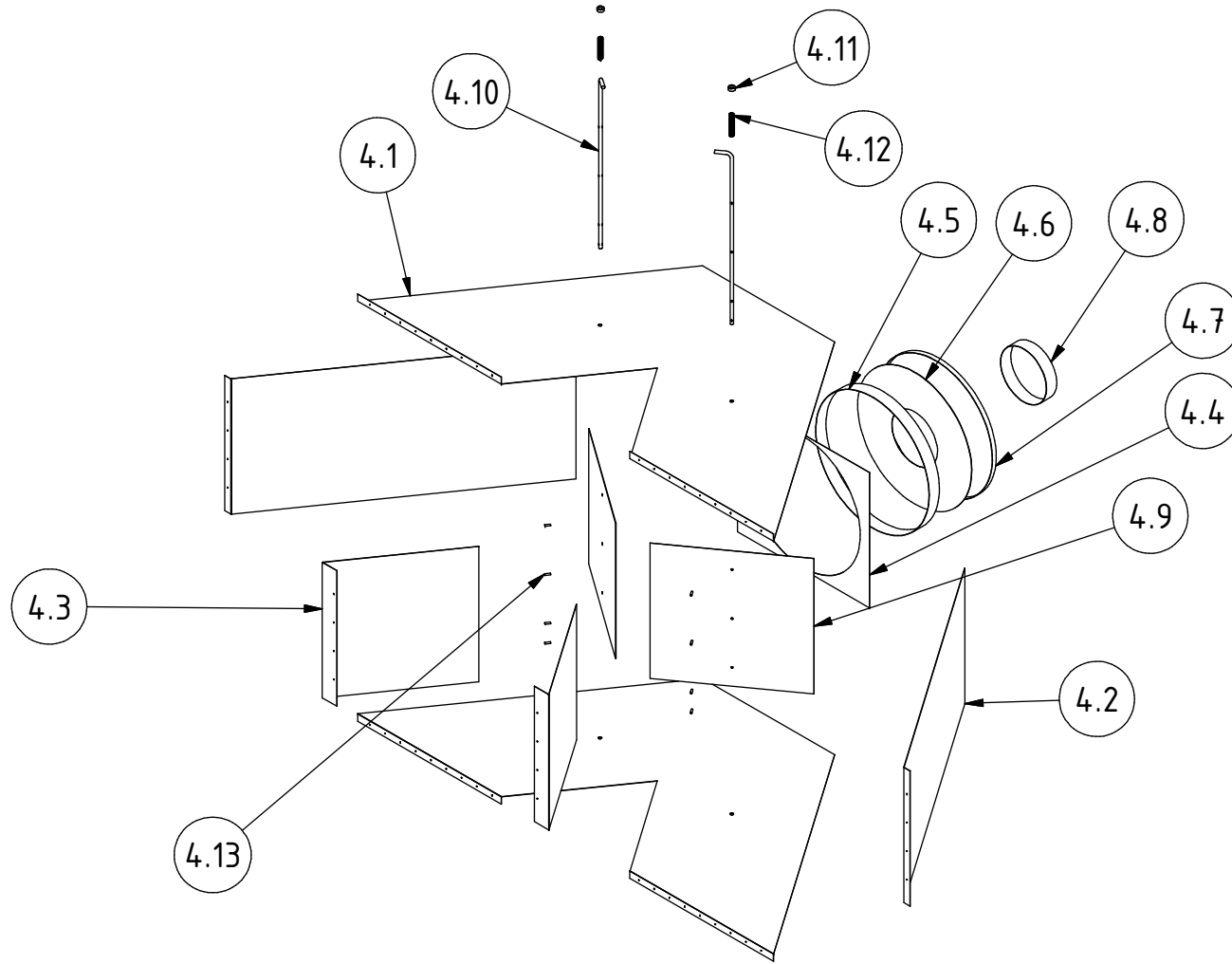

PROJEKT Batch Tray Dryer fuer Lebensmittel		ERSTELLT VON J. Zeron		GENEHMIGT VON A. Morillo		DATE 10/08/2021		VERSION 1.0	
TEIL-NAME Luftdampfer		DATEI-NAME Air damper.ipn						TEIL-CODE 4.0	
ENTWICKELT VON Practical Action		UMGESTALTET VON OHO e.V.		DOK. TYP Assembly		WERKSTOFF		MENGE -	
				LIZENZ CC-BY-SA 4.0		SCALE 1:25		SEITE 17 /28	

PLAN (1 : 20)

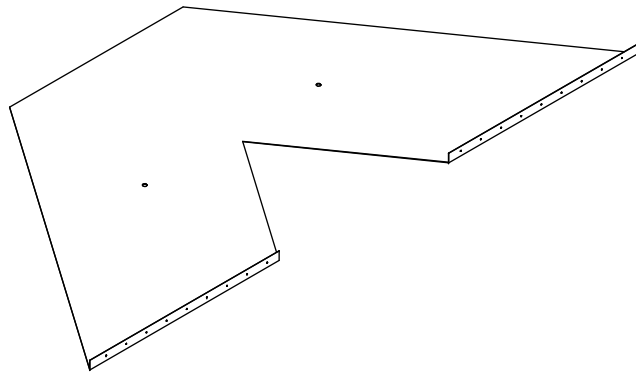
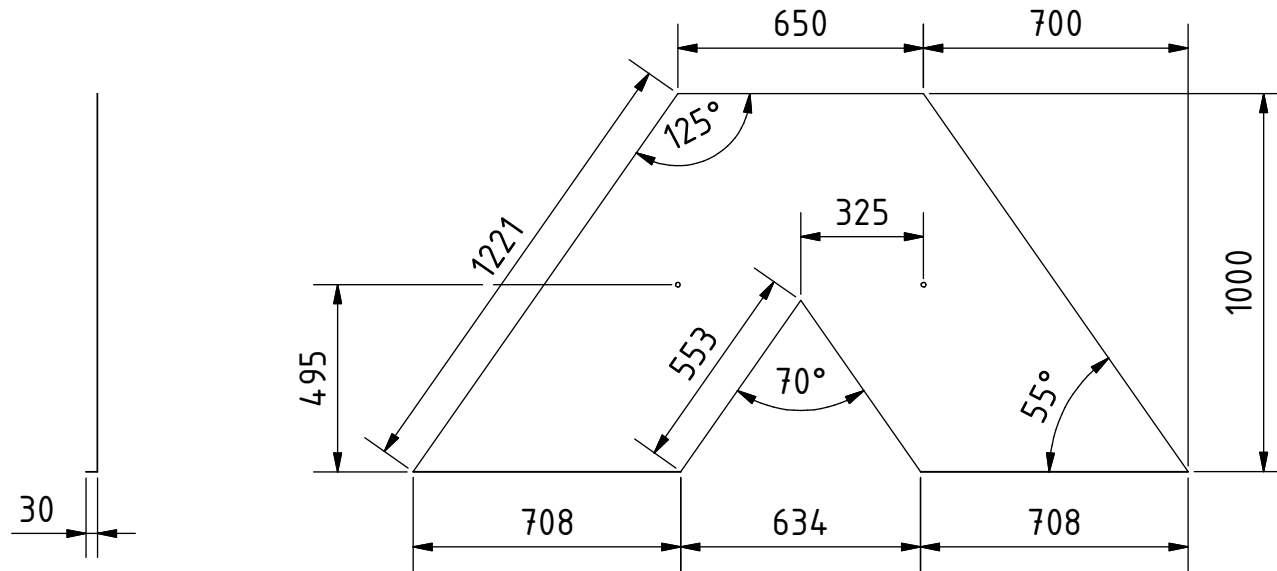

Hinweis: Alle einheiten in mm.

PROJEKT Batch Tray Dryer fuer Lebensmittel	ERSTELLT VON J. Zeron	GENEHMIGT VON A. Morillo	DATE 10/08/2021	VERSION 1.0
TEIL-NAME Deckplatte	DATEI-NAME Top plate.ipt			TEIL-CODE 4.1
ENTWICKELT VON	UMGESTALTET VON 	DOK. TYP Part	WERKSTOFF 18G weichstahlplatte	MENGE 2
Practical Action	OHO e.V.	LIZENZ CC-BY-SA 4.0	SCALE 1:20	SEITE 18 /28

ELEVATION (1 : 12)

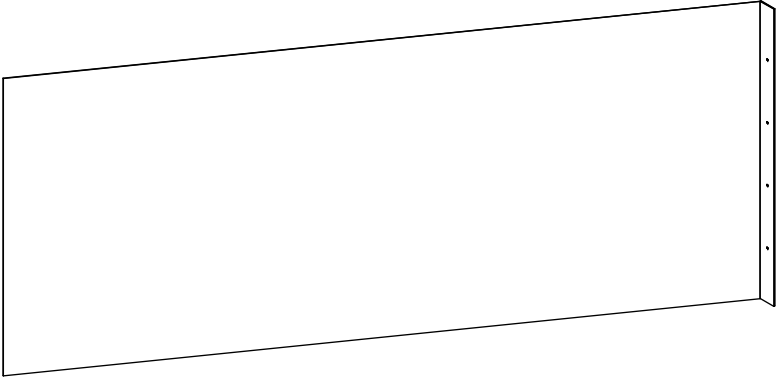
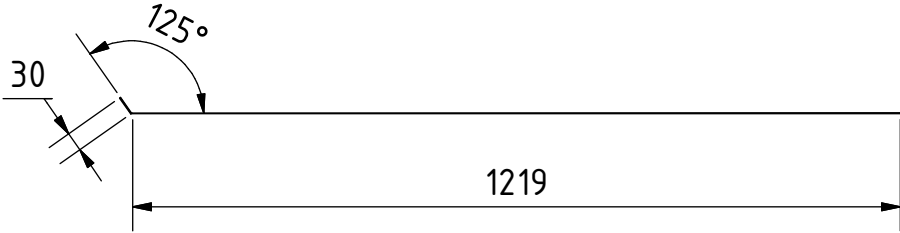
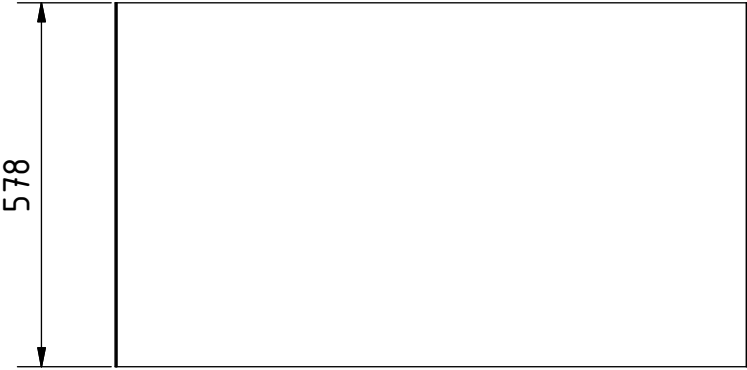
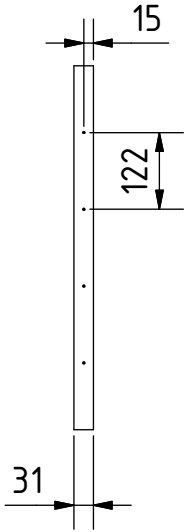

Hinweis: Alle einheiten in mm.

PROJEKT Batch Tray Dryer fuer Lebensmittel	ERSTELLT VON J. Zeron	GENEHMIGT VON A. Morillo	DATE 10/08/2021	VERSION 1.0
TEIL-NAME Seitenplatte A	DATEI-NAME Side plate A.ipt			TEIL-CODE 4.2
ENTWICKELT VON Practical Action	UMGESTALTET VON OHO e.V.	DOK. TYP Part	WERKSTOFF 18G weichstahlplatte	MENGE 2
		LIZENZ CC-BY-SA 4.0	SCALE 1:12	SEITE 19 /28

ELEVATION (1 : 10)

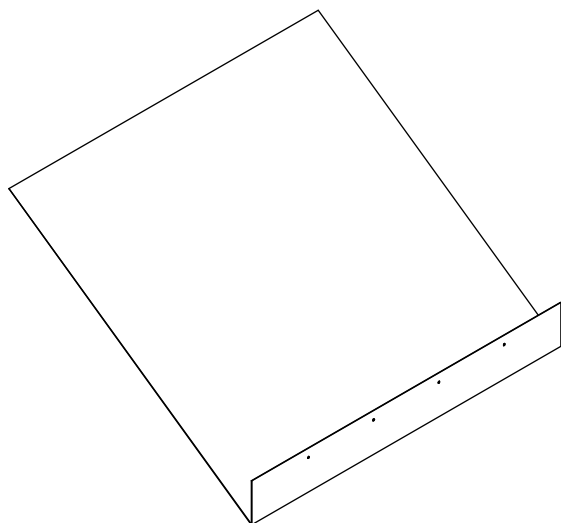
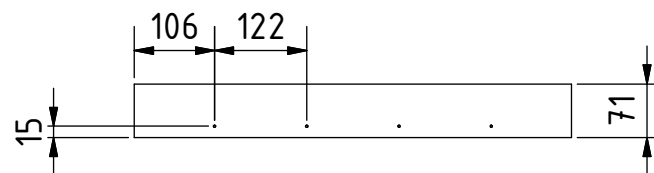
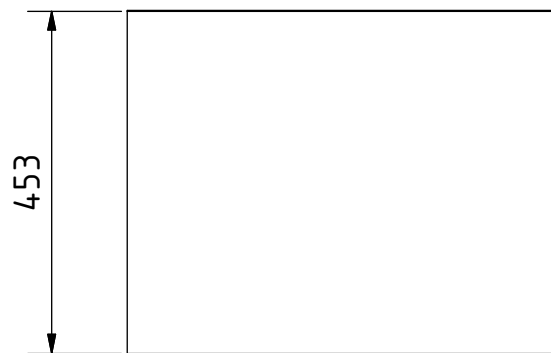
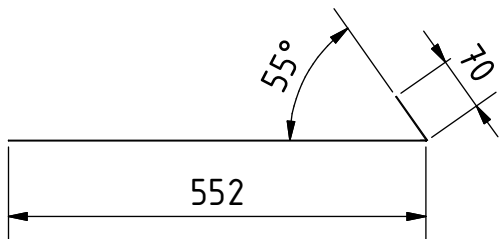

Hinweis: Alle einheiten in mm.

PROJEKT Batch Tray Dryer fuer Lebensmittel	ERSTELLT VON J. Zeron	GENEHMIGT VON A. Morillo	DATE 10/08/2021	VERSION 1.0
TEIL-NAME Seitenplatte B	DATEI-NAME Side plate B.ipt			TEIL-CODE 4.3
ENTWICKELT VON Practical Action	UMGESTALTET VON OHO e.V.	DOK. TYP Part	WERKSTOFF 18G weichstahlplatte	MENGE 2
		LIZENZ CC-BY-SA 4.0	SCALE 1:10	SEITE 20 /28

ELEVATION (1 : 10)

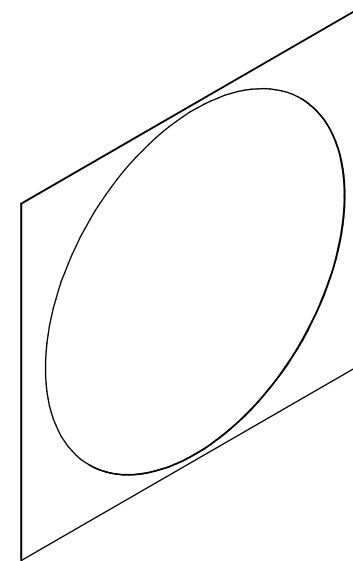
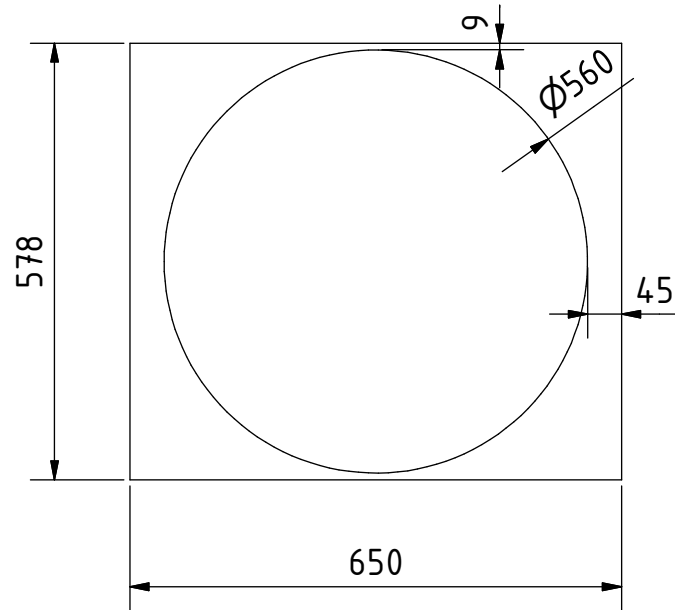

Hinweis: Alle einheiten in mm.

PROJEKT Batch Tray Dryer fuer Lebensmittel		ERSTELLT VON J. Zeron	GENEHMIGT VON A. Morillo	DATE 10/08/2021	VERSION 1.0
TEIL-NAME Ruckplatte		DATEI-NAME Back plate.ipt			TEIL-CODE 4.4
ENTWICKELT VON Practical Action	UMGESTALTET VON OHO e.V.	DOK. TYP Part	WERKSTOFF 18G weichstahlplatte	MENGE 1	
		LIZENZ CC-BY-SA 4.0	SCALE 1:10	SEITE 21 /28	

ELEVATION (1 : 10)

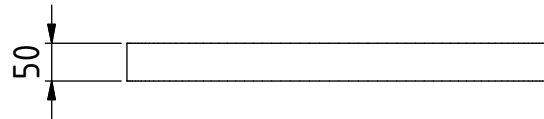
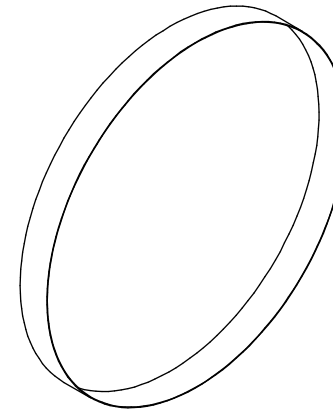
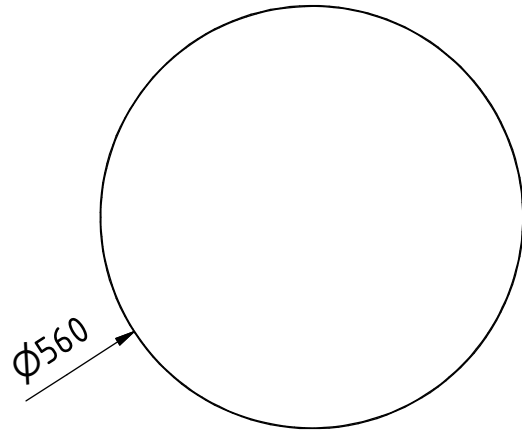

Hinweis: Alle einheiten in mm.

PROJEKT Batch Tray Dryer fuer Lebensmittel	ERSTELLT VON J. Zeron	GENEHMIGT VON A. Morillo	DATE 10/08/2021	VERSION 1.0
TEIL-NAME Anschlussmuffe	DATEI-NAME Connection sleeve.ipt			TEIL-CODE 4.5
ENTWICKELT VON Practical Action	UMGESTALTET VON OHO e.V.	DOK. TYP Part	WERKSTOFF 18G weichstahlplatte	MENGE 1
		LIZENZ CC-BY-SA 4.0	SCALE 1:10	SEITE 22 /28

ELEVATION (1 : 10)

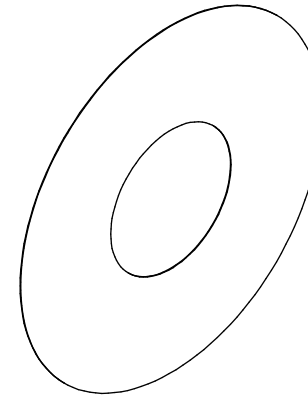
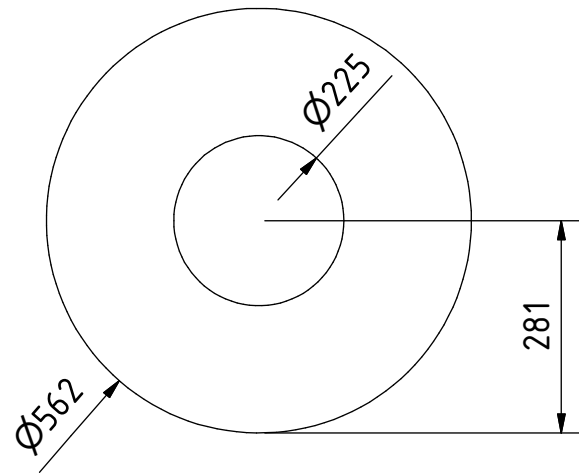

Hinweis: Alle einheiten in mm.

PROJEKT Batch Tray Dryer fuer Lebensmittel	ERSTELLT VON J. Zeron	GENEHMIGT VON A. Morillo	DATE 10/08/2021	VERSION 1.0
TEIL-NAME Adapter A.1	DATEI-NAME Adaptor A.1.ipt			TEIL-CODE 4.6
ENTWICKELT VON Practical Action	UMGESTALTET VON OHO e.V.	DOK. TYP Part	WERKSTOFF 18G weichstahlplatte	MENGE 1
		LIZENZ CC-BY-SA 4.0	SCALE 1:10	SEITE 23 /28

ELEVATION (1 : 10)

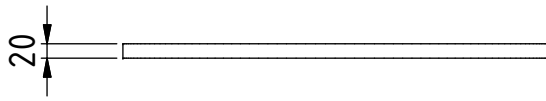
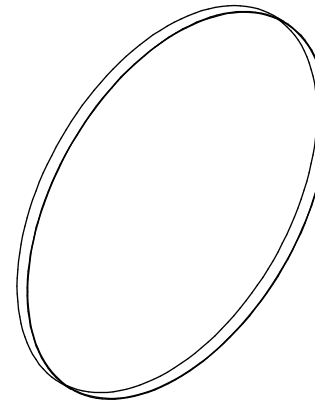
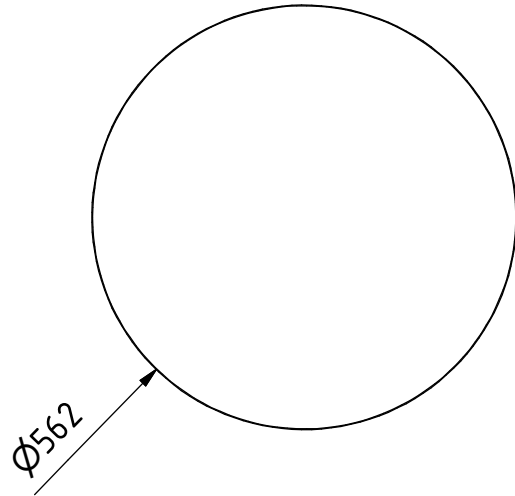

Hinweis: Alle einheiten in mm.

PROJEKT Batch Tray Dryer fuer Lebensmittel	ERSTELLT VON J. Zeron	GENEHMIGT VON A. Morillo	DATE 10/08/2021	VERSION 1.0
TEIL-NAME Adapter A.2	DATEI-NAME Adaptor A.2.ipt			TEIL-CODE 4.7
ENTWICKELT VON Practical Action	UMGESTALTET VON OHO e.V.	DOK. TYP Part	WERKSTOFF 18G weichstahlplatte	MENGE 1
		LIZENZ CC-BY-SA 4.0	SCALE 1:10	SEITE 24 /28

ELEVATION (1 : 5)

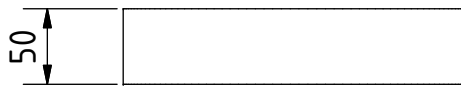
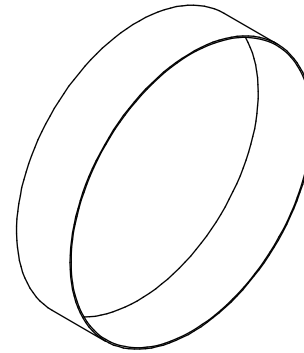
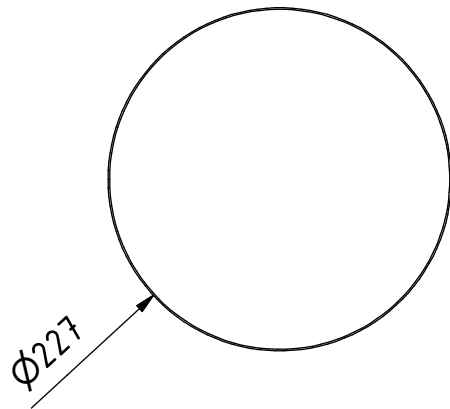

Hinweis: Alle einheiten in mm.

PROJEKT Batch Tray Dryer fuer Lebensmittel	ERSTELLT VON J. Zeron	GENEHMIGT VON A. Morillo	DATE 10/08/2021	VERSION 1.0
TEIL-NAME Adapter B	DATEI-NAME Adaptor B.ipt			TEIL-CODE 4.8
ENTWICKELT VON Practical Action	UMGESTALTET VON OHO e.V.	DOK. TYP Part	WERKSTOFF 18G weichstahlplatte	MENGE 1
		LIZENZ CC-BY-SA 4.0	SCALE 1:5	SEITE 25 /28

ELEVATION (1 : 10)

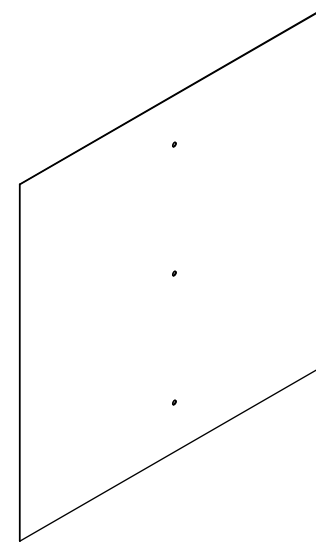
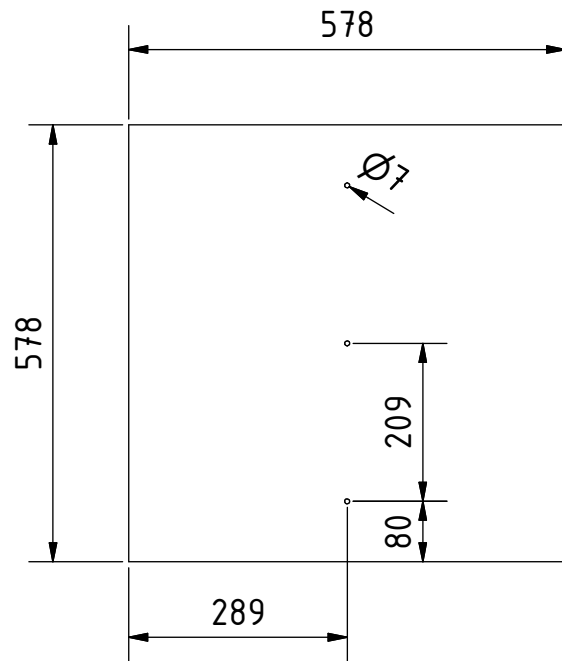

Hinweis: Alle einheiten in mm.

PROJEKT Batch Tray Dryer fuer Lebensmittel		ERSTELLT VON J. Zeron	GENEHMIGT VON A. Morillo	DATE 10/08/2021	VERSION 1.0
TEIL-NAME Dampferplatte		DATEI-NAME Damper plate.ipt			TEIL-CODE 4.9
ENTWICKELT VON Practical Action	UMGESTALTET VON OHO e.V.	DOK. TYP Part	WERKSTOFF 18G weichstahlplatte	MENGE 2	
		LIZENZ CC-BY-SA 4.0	SCALE 1:10	SEITE 26 /28	

ELEVATION (1 : 8)

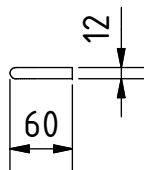
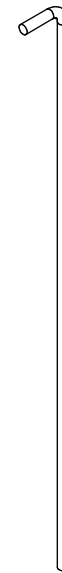
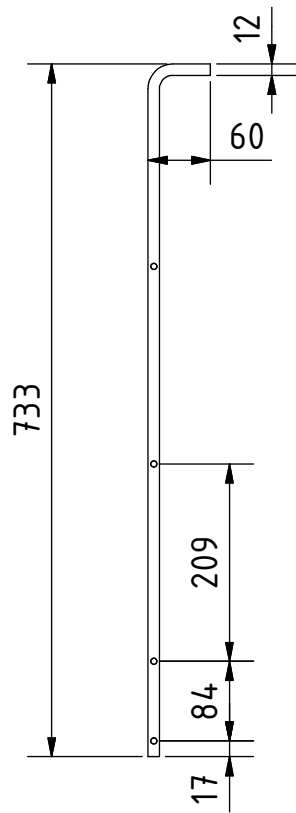

Hinweis: Alle einheiten in mm.

PROJEKT Batch Tray Dryer fuer Lebensmittel	ERSTELLT VON J. Zeron	GENEHMIGT VON A. Morillo	DATE 10/08/2021	VERSION 1.0
TEIL-NAME Dampferstange	DATEI-NAME Damper bar.ipt			TEIL-CODE 4.10
ENTWICKELT VON Practical Action	UMGESTALTET VON OHO e.V.	DOK. TYP Part	WERKSTOFF Stahl A36	MENGE 2
		LIZENZ CC-BY-SA 4.0	SCALE 1:8	SEITE 27 /28

PLAN (2 : 1)

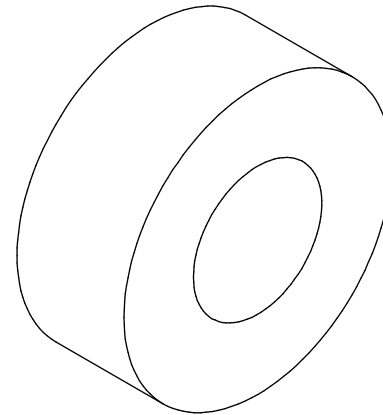
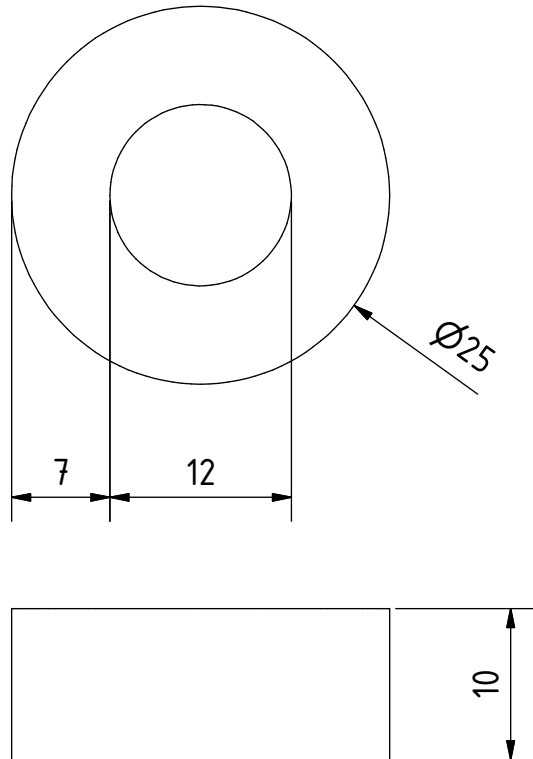

Hinweis: Alle einheiten in mm.

PROJEKT Batch Tray Dryer fuer Lebensmittel	ERSTELLT VON J. Zeron	GENEHMIGT VON A. Morillo	DATE 10/08/2021	VERSION 1.0
TEIL-NAME Dampferstopp	DATEI-NAME Damper stop.ipt			TEIL-CODE 4.11
ENTWICKELT VON Practical Action	UMGESTALTET VON OHO e.V.	DOK. TYP Part	WERKSTOFF Stahl A36	MENGE 2
		LIZENZ CC-BY-SA 4.0	SCALE 2:1	SEITE 28 /28