

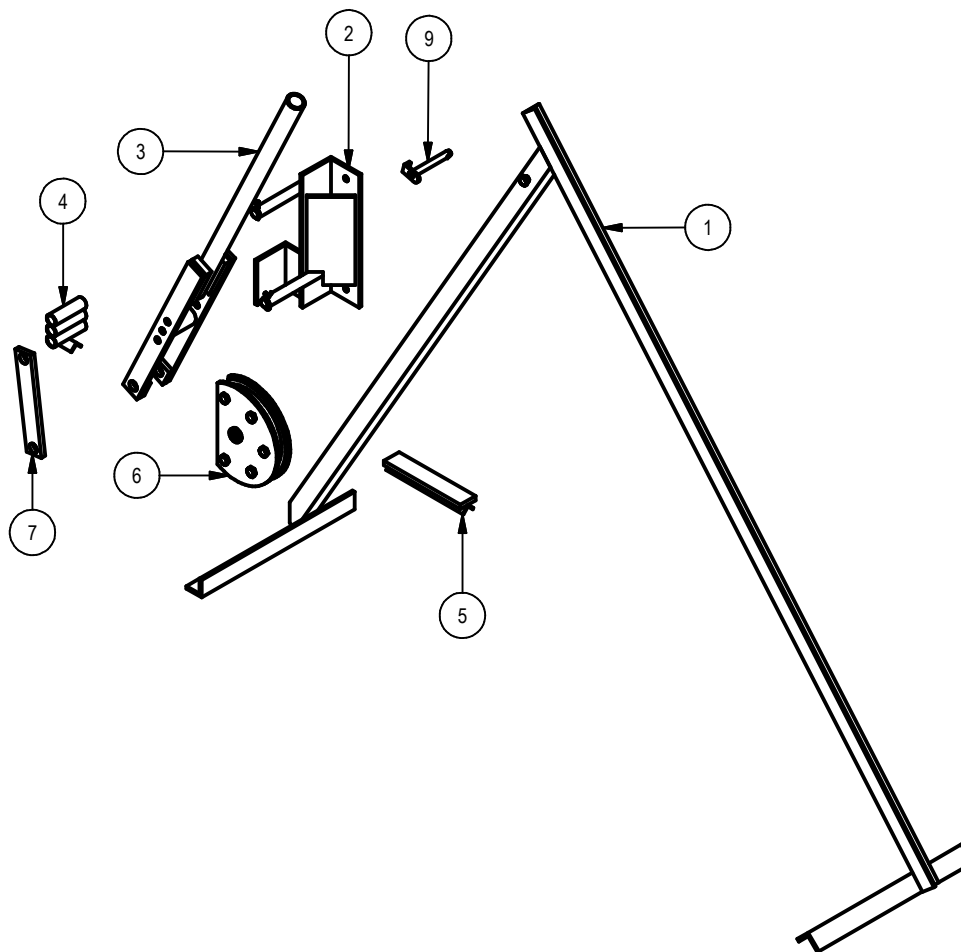

PROYECTO Dobladora de Tubos	CREADO POR A. PARDO	APROBADO POR D. Jaeger		
NOMBRE DE PIEZA PIPE BENDING MACHINE	CÓDIGO A1	TIPO DE DOCUMENTO ASSEMBLY	MATERIAL	
 OPEN SOURCE ECOLOGY GERMANY	LICENCIA CERN-OHL	NOMBRE DE ARCHIVO PIPE BENDING MACHINE.iam	VERSIÓN 1.0	CANTIDAD
	Open Source Ecology e.V Knobelsdorffstr. 22 14059 Berlin www.ose-germany.de +49 (0) 30 / 92282426		ESCALA 1 / 16	HOJA 1



PROYECTO Dobladora de Tubos	CREADO POR A. PARDO	APROBADO POR D. Jaeger		
NOMBRE DE PIEZA PIPE BENDING MACHINE	CÓDIGO A2	TIPO DE DOCUMENTO ASSEMBLY	MATERIAL	
 Open Source Ecology e.V. Knobelsdorffstr. 22 14059 Berlin www.ose-germany.de +49 (0) 30 / 92282426	LICENCIA CERN-OHL	NOMBRE DE ARCHIVO PIPE BENDING MACHINE.iam	VERSIÓN 1.0	CANTIDAD
		ESCALA 1 / 14	HOJA 2	FECHA 28-11-2020

PARTS LIST							
POS.	POS. OLD	CANT	NOMBRE DE PIEZA	NOMBRE DE ARCHIVO	TIPO PZA	ESPECIFICACIONES	HOJA
A1		1	PIPE BENDING MACHINE	PIPE BENDING MACHINE.iam	Production	Steel C45	1
A2		1	PIPE BENDING MACHINE	PIPE BENDING MACHINE.iam	Production	Steel C45	2
B1		1	PARTS LITS	PARTS LITS PIPE.iam	Production	Steel C45	3
1		1	SUB-PIPE BENDING MACHINE 1	SUB-PIPE BENDING MACHINE 1.iam	Production	Steel C45	4
1.1	1	1	FRAME	FRAME.ipt	Production	FRAME	5
1.2	4	1	MAIN PIN	MAIN PIN.ipt	Production	MAIN PIN	6
1.3	2	1	STIFFENER	STIFFENER.ipt	Production	STIFFENER	7
1.4	3	1	FORMER STOP	FORMER STOP.ipt	Production	FORMER STOP	8
1.5		2	SAE J487a - 3/32 x 1 Extended Prong Square Cut Type		Standard	Pin - Cotter	
2		1	SUB-PIPE BENDING MACHINE 2	SUB-PIPE BENDING MACHINE 2.iam	Production	Steel C45	9
2.1	9	1	FOOT	FOOT.ipt	Production	FOOT	10
2.2	6	1	SUPPORT LEG	SUPPORT LEG.ipt	Production	SUPPORT LEG	11
2.3	5	1	MAIN LEG	MAIN LEG.ipt	Production	MAIN LEG	12
3		1	SUB-PIPE BENDING MACHINE 3	SUB-PIPE BENDING MACHINE 3.iam	Production	Steel C45	13
3.1	18	1	HANDLE	HANDLE.ipt	Production	HANDLE	14
3.2	21	1	FORMER SPACER	FORMER SPACER.ipt	Production	FORMER SPACER	15
3.3	19	1	HANDLE ARM	HANDLE ARM.ipt	Production	HANDLE ARM	16
3.4	20	1	HANDLE SPACER	HANDLE SPACER.ipt	Production	HANDLE SPACER	17
3.5	17	1	ROLLER	ROLLER.ipt	Production	ROLLER	18
4		1	SUB-PIPE BENDING MACHINE 4	SUB-PIPE BENDING MACHINE 4.iam	Production	Steel C45	19
4.1	14	1	ROLLER PIN	ROLLER PIN.ipt	Production	ROLLER PIN	20
4.2	15	1	PIN HANDLE	PIN HANDLE.ipt	Production	PIN HANDLE	21
5		1	SUB-PIPE BENDING MACHINE 5	SUB-PIPE BENDING MACHINE 5.iam	Production	Steel C45	22
5.1	10	1	STOP TUBE	STOP TUBE.ipt	Production	STOP TUBE	23
5.2	11	1	STOP ANGLE	STOP ANGLE.ipt	Production	STOP ANGLE	24
6		1	SUB-PIPE BENDING MACHINE 6	SUB-PIPE BENDING MACHINE 6.iam	Production	Steel C45	25
6.1	12	1	GUIDE ANGLE	GUIDE ANGLE.ipt	Production	GUIDE ANGLE	26
6.2	13	1	GUIDE BASE	GUIDE BASE.ipt	Production	GUIDE BASE	27
7		1	SUB-PIPE BENDING MACHINE 7	SUB-PIPE BENDING MACHINE 7.iam	Production	Steel C45	28
7.1	23	1	FORMER BASE	FORMER BASE.ipt	Production	FORMER SIDE	29
7.2	24	1	FORMER SIDE	FORMER SIDE.ipt	Production	FORMER SIDE	30
7.3	25	1	SPACER TUBE	SPACER TUBE.ipt	Production	SPACER TUBE	31
7.4	22	1	PIN LINK	PIN LINK.ipt	Production	PIN LINK	32

PROYECTO Dobladora de Tubos		CREADO POR A. PARDO		APROBADO POR D. Jaeger	
NOMBRE DE PIEZA ASSEMBLY		CÓDIGO B1		TIPO DE DOCUMENTO PARTS LIST	
 Open Source Ecology e.V Knobelsdorffstr. 22 14059 Berlin www.ose-germany.de +49 (0) 30 / 92282426		LICENCIA CERN-OHL		MATERIAL STEEL C45	
		NOMBRE DE ARCHIVO parts list pipe.iam		VERSIÓN 1.0	
		ESCALA 1 / 20		CANTIDAD 1	
				HOJA 3	
				FECHA 29-10-2020	

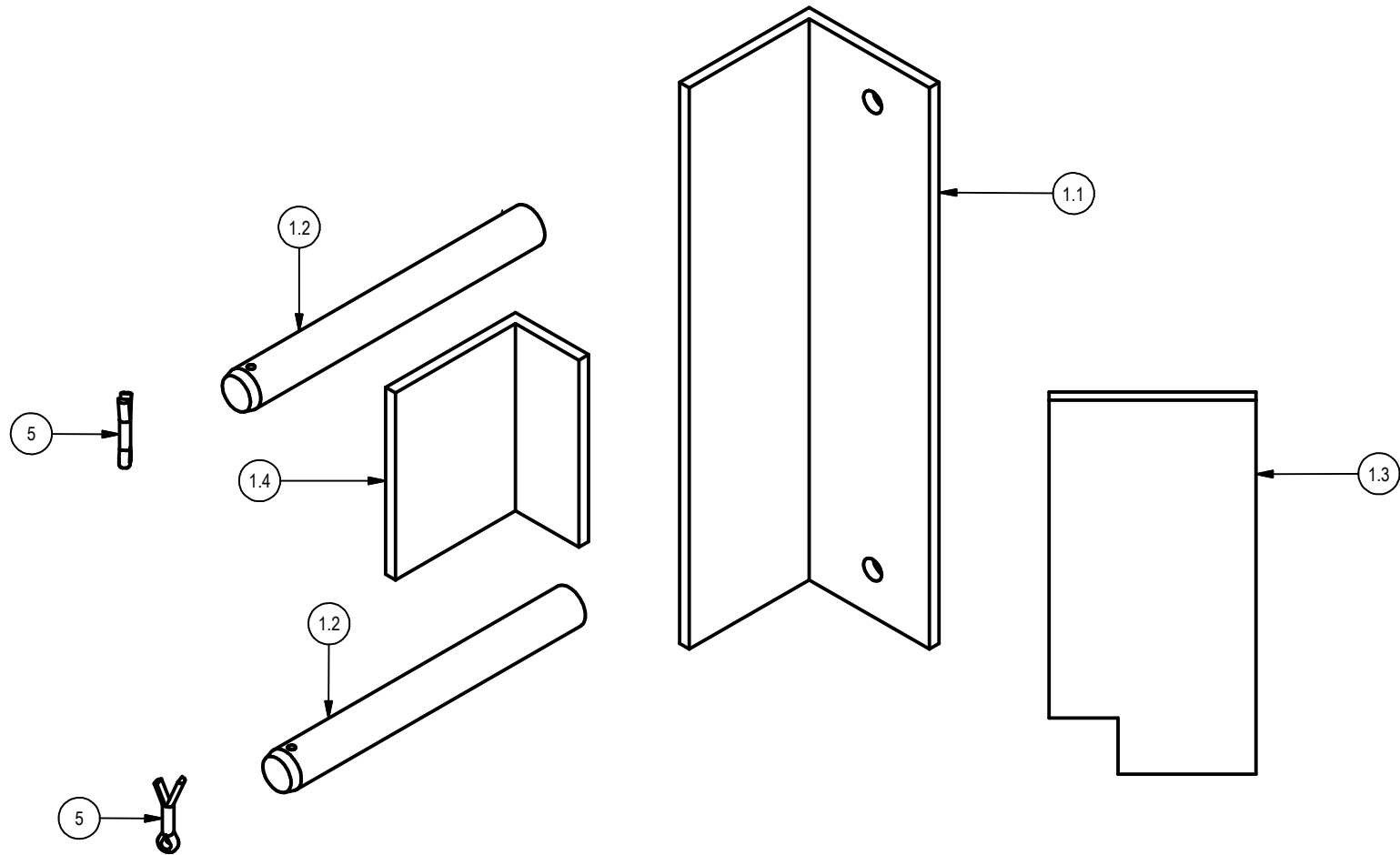

PROYECTO Dobladora de Tubos	CREADO POR A. PARDO	APROBADO POR D. Jaeger		
NOMBRE DE PIEZA ASSEMBLY	CÓDIGO 1	TIPO DE DOCUMENTO ASSEMBLY	MATERIAL Steel C45	
 Open Source Ecology e.V. Knobelsdorffstr. 22 14059 Berlin www.ose-germany.de +49 (0) 30 / 92282426	LICENCIA CERN-OHL	NOMBRE DE ARCHIVO SUB-PIPE BENDING MACHINE 1.iam	VERSIÓN 1.0	CANTIDAD
		ESCALA 1 / 3	HOJA 1	FECHA 26-11-2020

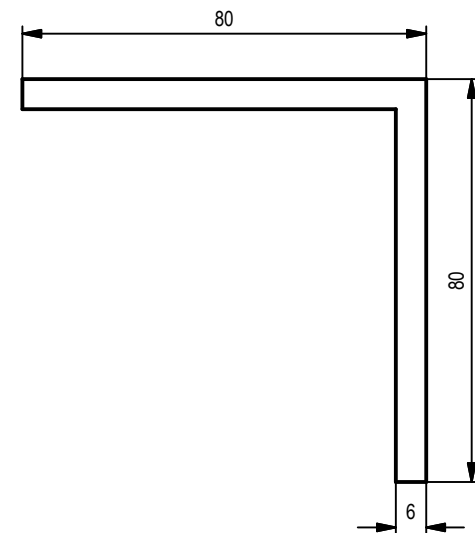
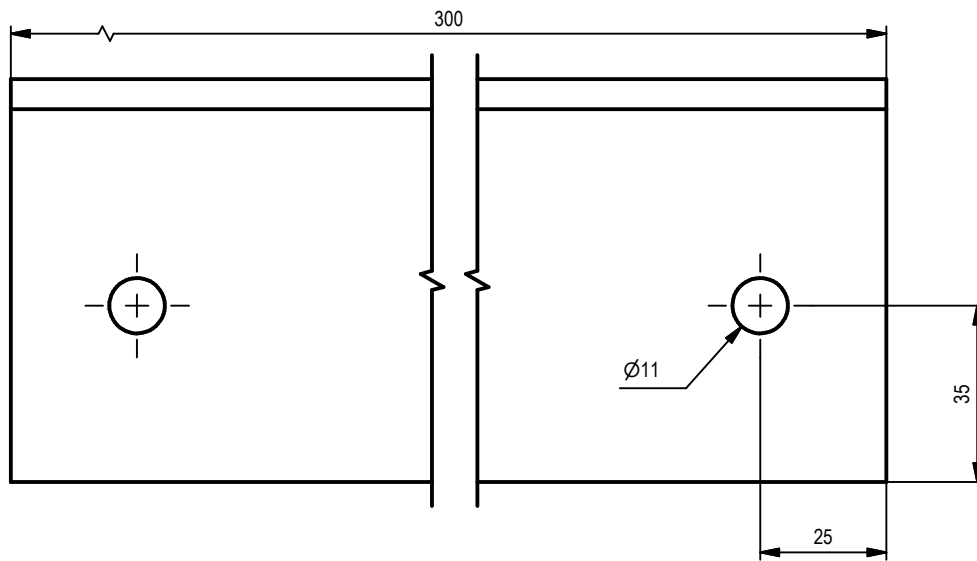
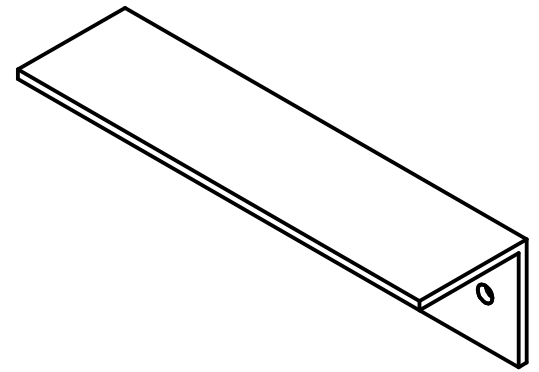

PROYECTO Dobladora de Tubos		CREADO POR A. PARDO		APROBADO POR D. Jaeger	
NOMBRE DE PIEZA FRAME		CÓDIGO 1.1		TIPO DE DOCUMENTO Production	
 Open Source Ecology e.V. Knobelsdorffstr. 22 14059 Berlin www.ose-germany.de +49 (0) 30 / 92282426		LICENCIA CERN-OHL		NOMBRE DE ARCHIVO FRAME.ipt	
		ESCALA 1 : 1.5		MATERIAL Steel C45	
		VERSIÓN 1.0		CANTIDAD 1	
		HOJA 5		FECHA 26-10-2020	

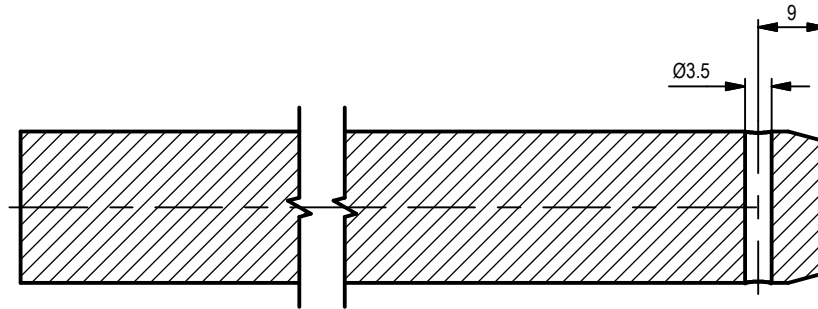
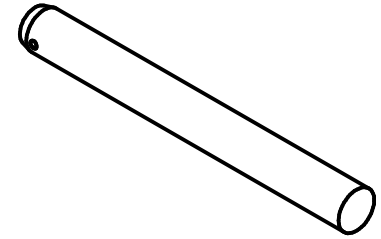

SECTION B-B
SCALE 1 : 1

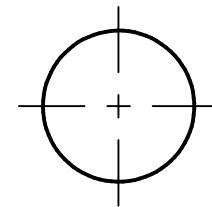
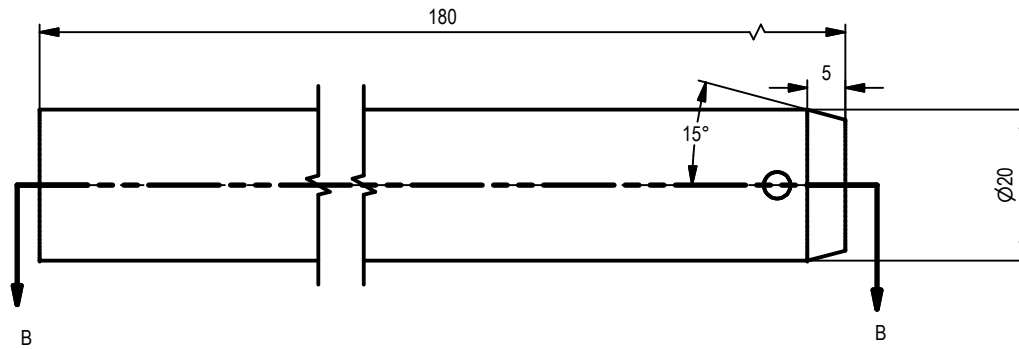

PROYECTO Dobladora de Tubos		CREADO POR A. PARDO		APROBADO POR D. Jaeger	
NOMBRE DE PIEZA MAIN PIN		CÓDIGO 1.2		TIPO DE DOCUMENTO Production	
 Open Source Ecology e.V. Knobelsdorffstr. 22 14059 Berlin www.ose-germany.de +49 (0) 30 / 92282426		LICENCIA CERN-OHL		NOMBRE DE ARCHIVO MAIN PIN.ipt	
		MATERIAL Steel C45		VERSIÓN 1.0	
		CANTIDAD 1		ESCALA 1 : 1	
		HOJA 6		FECHA 26-10-2020	

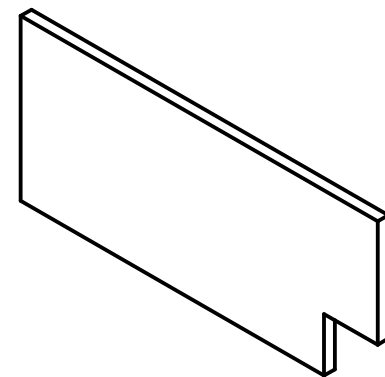
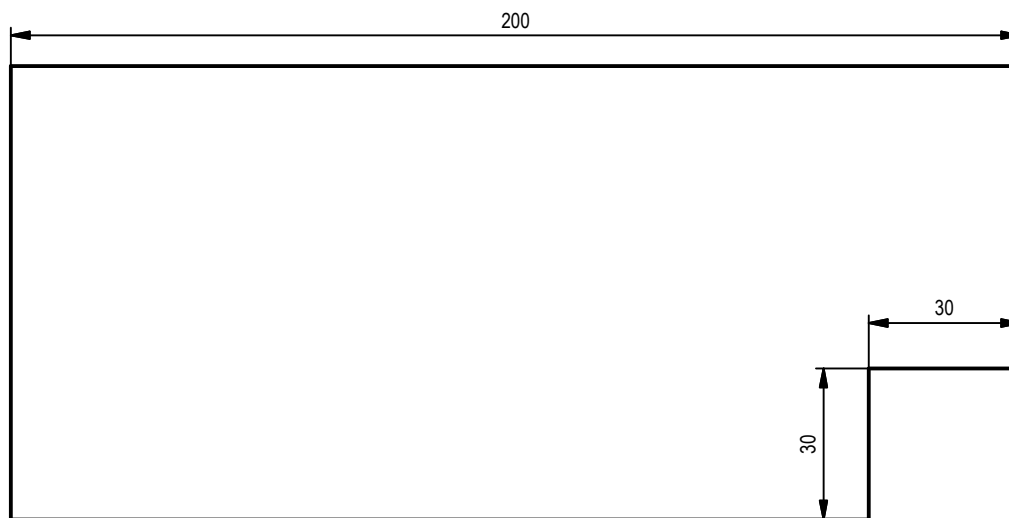
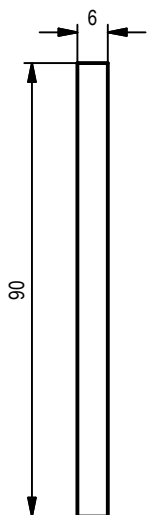

PROYECTO Dobladora de Tubos	CREADO POR A. PARDO	APROBADO POR D. Jaeger		
NOMBRE DE PIEZA STIFFENER	CÓDIGO 1.3	TIPO DE DOCUMENTO Production	MATERIAL Steel C45	
 <p>Open Source Ecology e.V. Knobelsdorffstr. 22 14059 Berlin www.ose-germany.de +49 (0) 30 / 92282426</p>	LICENCIA CERN-OHL	NOMBRE DE ARCHIVO STIFFENER.ipt	VERSIÓN 1.0	CANTIDAD 1
		ESCALA 1 : 1.5	HOJA 7	FECHA 26-10-2020

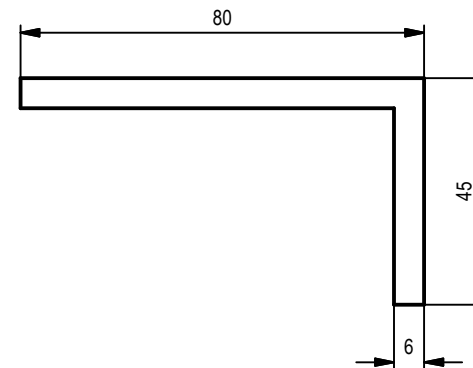
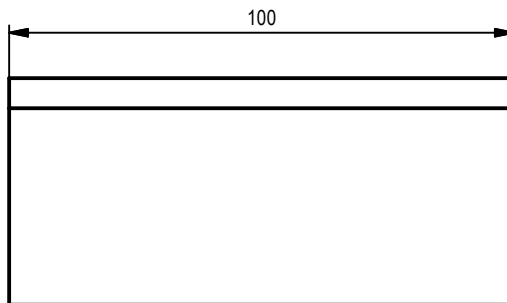
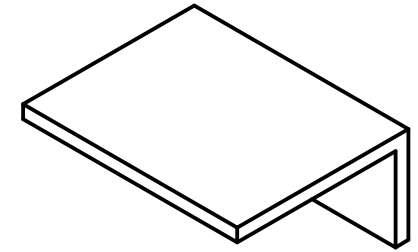

PROYECTO Dobladora de Tubos	CREADO POR A. PARDO	APROBADO POR D. Jaeger		
NOMBRE DE PIEZA FORMER STOP	CÓDIGO 1.4	TIPO DE DOCUMENTO Production	MATERIAL Steel C45	
 <p>Open Source Ecology e.V. Knobelsdorffstr. 22 14059 Berlin www.ose-germany.de +49 (0) 30 / 92282426</p>	LICENCIA CERN-OHL	NOMBRE DE ARCHIVO FORMER STOP.ipt	VERSIÓN 1.0	CANTIDAD 1
		ESCALA 1 : 1.5	HOJA 8	FECHA 26-10-2020

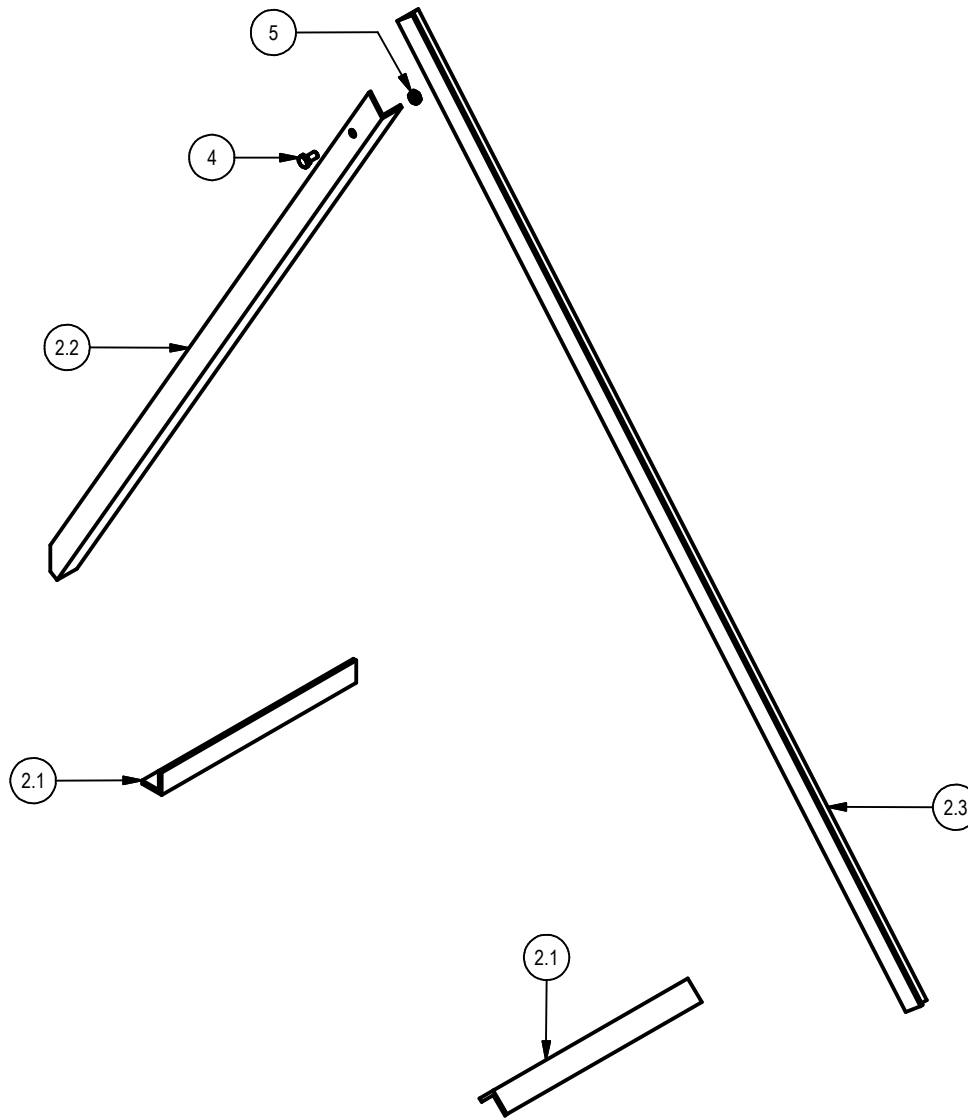

PROYECTO Dobladora de Tubos	CREADO POR A. PARDO	APROBADO POR D. Jaeger		
NOMBRE DE PIEZA ASSEMBLY	CÓDIGO 2	TIPO DE DOCUMENTO ASSEMBLY	MATERIAL Steel C45	
 Open Source Ecology e.V. Knobelsdorffstr. 22 14059 Berlin www.ose-germany.de +49 (0) 30 / 92282426	LICENCIA CERN-OHL	NOMBRE DE ARCHIVO SUB-PIPE BENDING MACHINE 2.iam	VERSIÓN 1.0	CANTIDAD 1
		ESCALA 1 / 11	HOJA 9	FECHA 26-11-2020

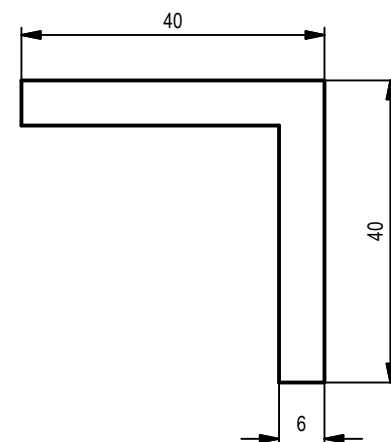
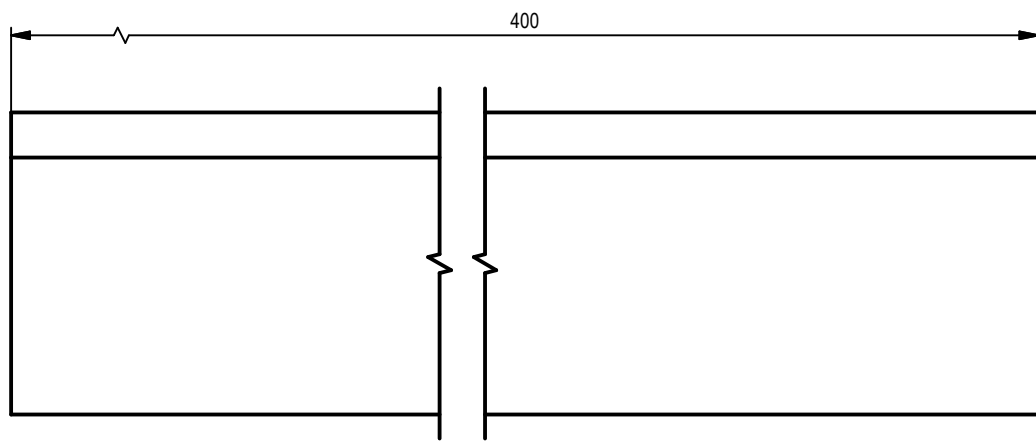
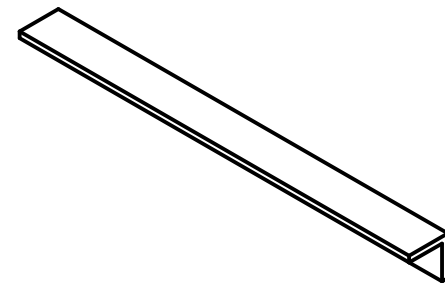

PROYECTO Dobladora de Tubos		CREADO POR A. PARDO		APROBADO POR D. Jaeger		
NOMBRE DE PIEZA FOOT		CÓDIGO 2.1	TIPO DE DOCUMENTO Production		MATERIAL Steel C45	
 Open Source Ecology e.V. Knobelsdorffstr. 22 14059 Berlin www.ose-germany.de +49 (0) 30 / 92282426		LICENCIA CERN-OHL	NOMBRE DE ARCHIVO FOOT.ipt		VERSIÓN 1.0	CANTIDAD 1
			ESCALA 1 : 1	HOJA 10	FECHA 26-10-2020	

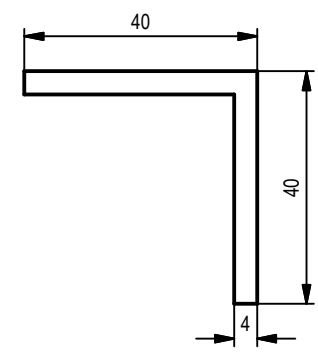
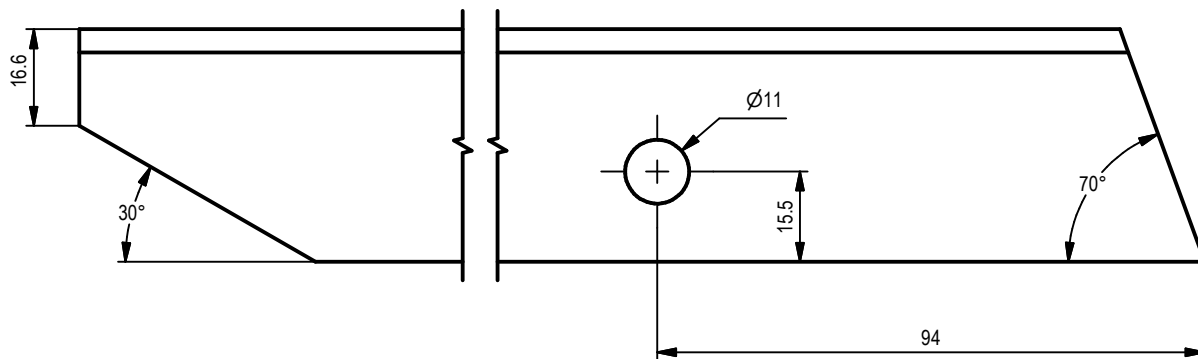
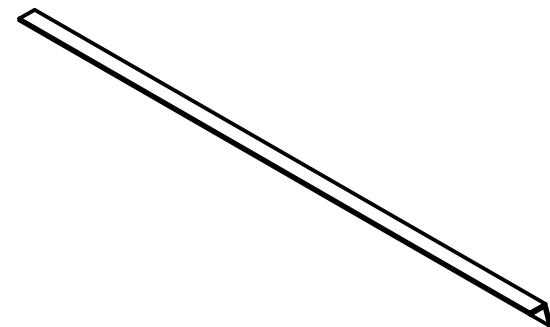

PROYECTO Dobladora de Tubos		CREADO POR A. PARDO		APROBADO POR D. Jaeger	
NOMBRE DE PIEZA SUPPORT LEG		CÓDIGO 2.2		TIPO DE DOCUMENTO Production	MATERIAL Steel C45
 Open Source Ecology e.V. Knobelsdorffstr. 22 14059 Berlin www.ose-germany.de +49 (0) 30 / 92282426		LICENCIA CERN-OHL		NOMBRE DE ARCHIVO SUPPORT LEG.ipt	VERSIÓN 1.0
			ESCALA 1 : 1.3	HOJA 11	CANTIDAD 1
					FECHA 26-10-2020

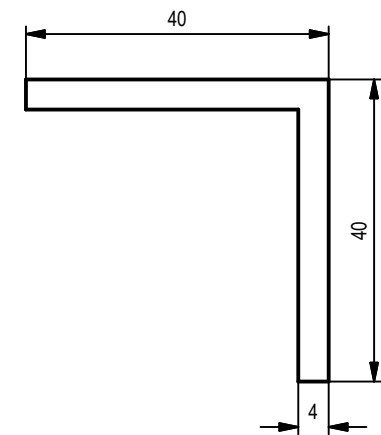
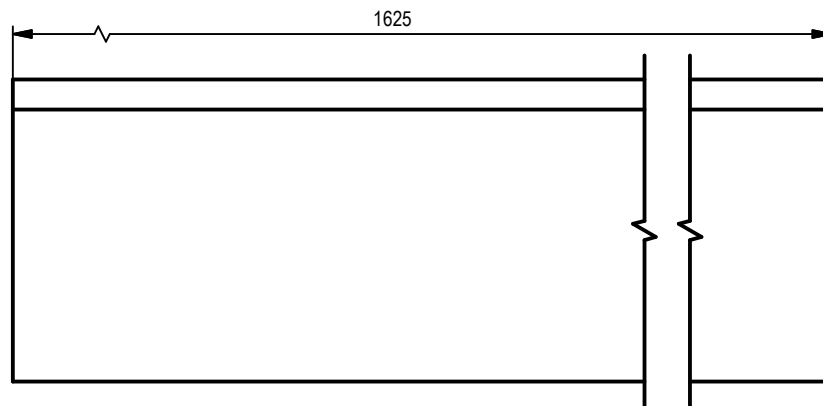
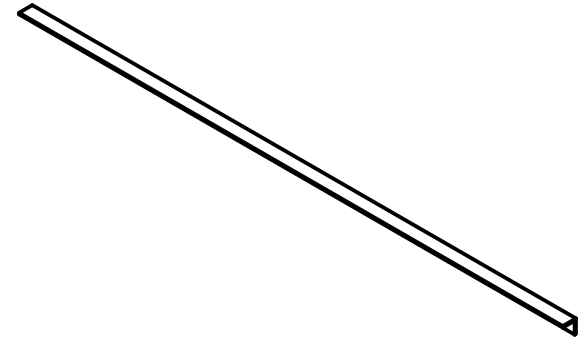

PROYECTO Dobladora de Tubos		CREADO POR A. PARDO		APROBADO POR D. Jaeger		
NOMBRE DE PIEZA MAIN LEG		CÓDIGO 2.3	TIPO DE DOCUMENTO Production		MATERIAL Steel C45	
 Open Source Ecology e.V. Knobelsdorffstr. 22 14059 Berlin www.ose-germany.de +49 (0) 30 / 92282426		LICENCIA CERN-OHL	NOMBRE DE ARCHIVO MAIN LEG.ipt		VERSIÓN 1.0	CANTIDAD 1
			ESCALA 1 : 1	HOJA 12	FECHA 26-10-2020	

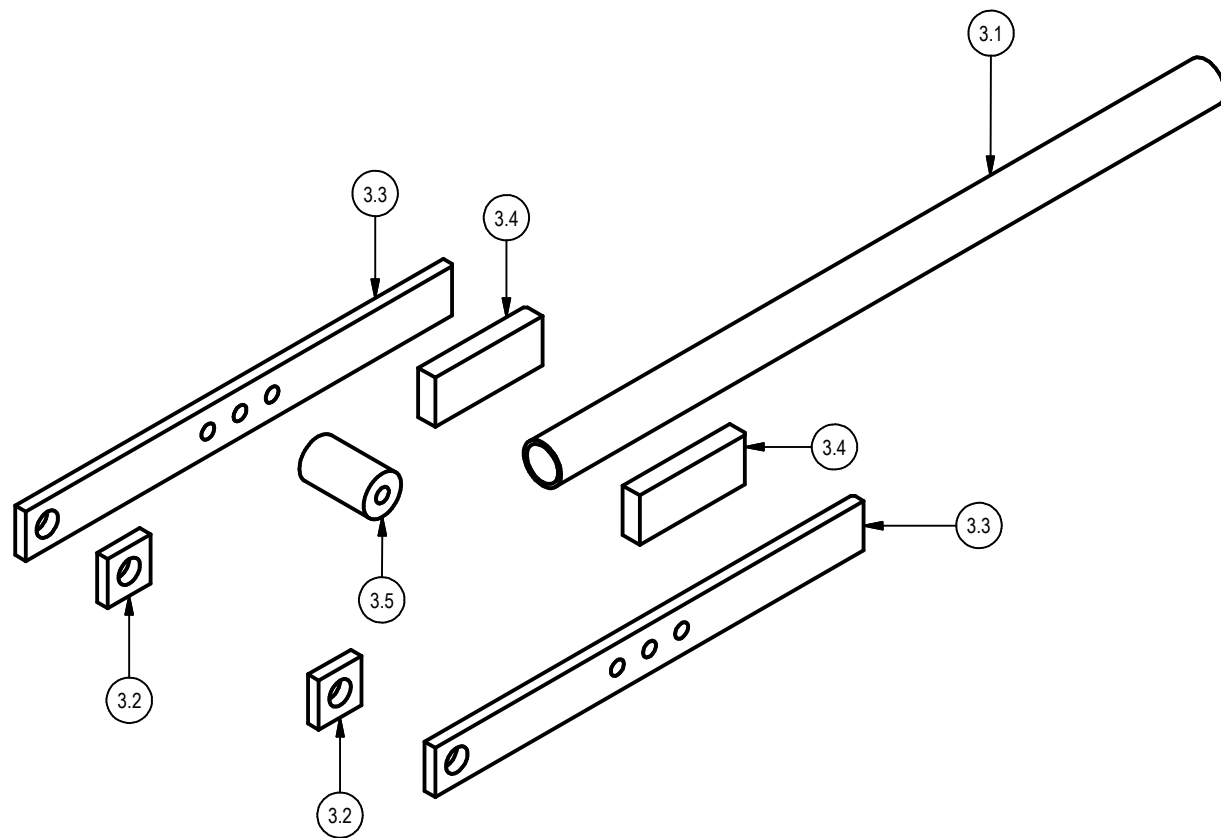

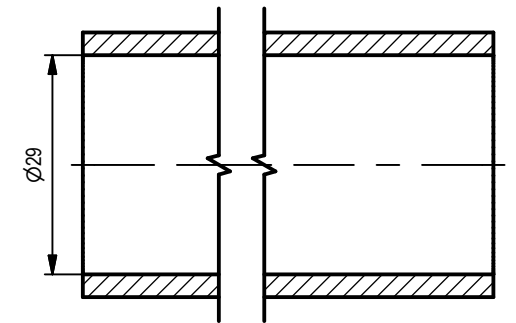
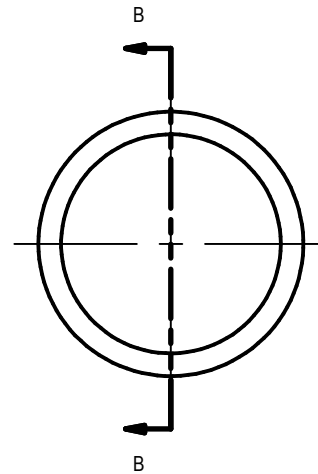
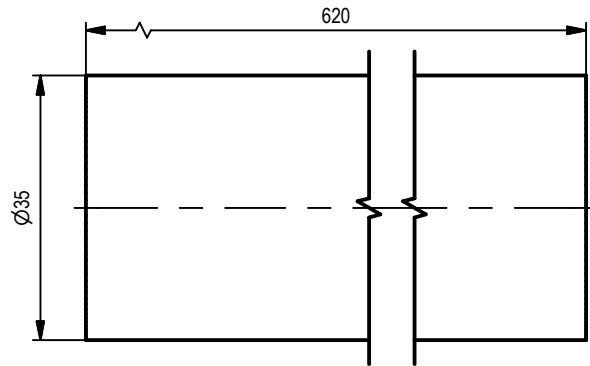
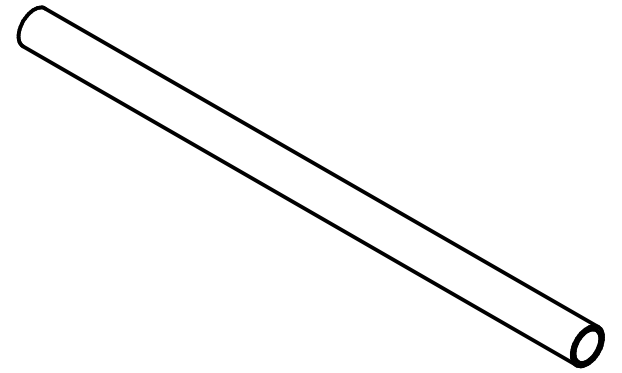

PROYECTO Dobladora de Tubos	CREADO POR A. PARDO	APROBADO POR D. Jaeger		
NOMBRE DE PIEZA ASSEMBLY	CÓDIGO 3	TIPO DE DOCUMENTO ASSEMBLY	MATERIAL Steel C45	
 Open Source Ecology e.V. Knobelsdorffstr. 22 14059 Berlin www.ose-germany.de +49 (0) 30 / 92282426	LICENCIA CERN-OHL	NOMBRE DE ARCHIVO SUB-PIPE BENDING MACHINE 3.iam	VERSIÓN 1.0	CANTIDAD 1
		ESCALA 1 / 5	HOJA 13	FECHA 26-11-2020



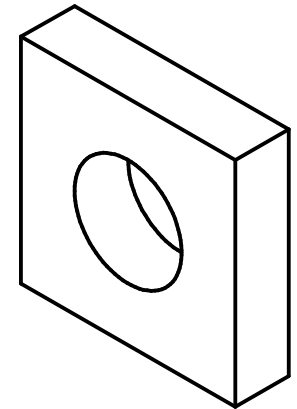
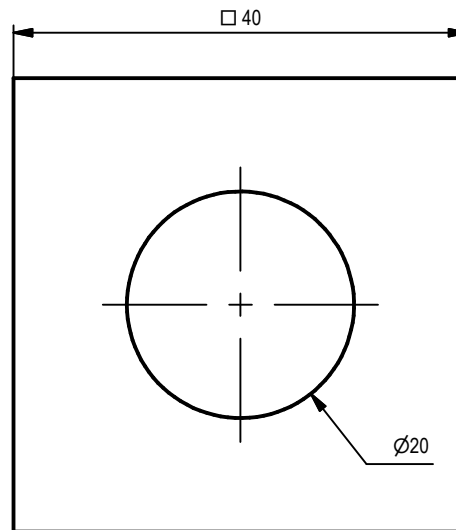
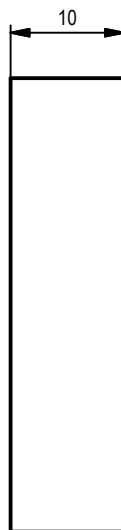

SECTION B-B
SCALE 1 : 1

PROYECTO Dobladora de Tubos		CREADO POR A. PARDO		APROBADO POR D. Jaeger	
NOMBRE DE PIEZA HANDLE		CÓDIGO 3.1		TIPO DE DOCUMENTO Production	
 Open Source Ecology e.V. Knobelsdorffstr. 22 14059 Berlin www.ose-germany.de +49 (0) 30 / 92282426		LICENCIA CERN-OHL		NOMBRE DE ARCHIVO HANDLE.ipt	
		ESCALA 1 : 1		MATERIAL Steel C45	
		VERSIÓN 1.0		CANTIDAD 1	
		HOJA 14		FECHA 26-10-2020	

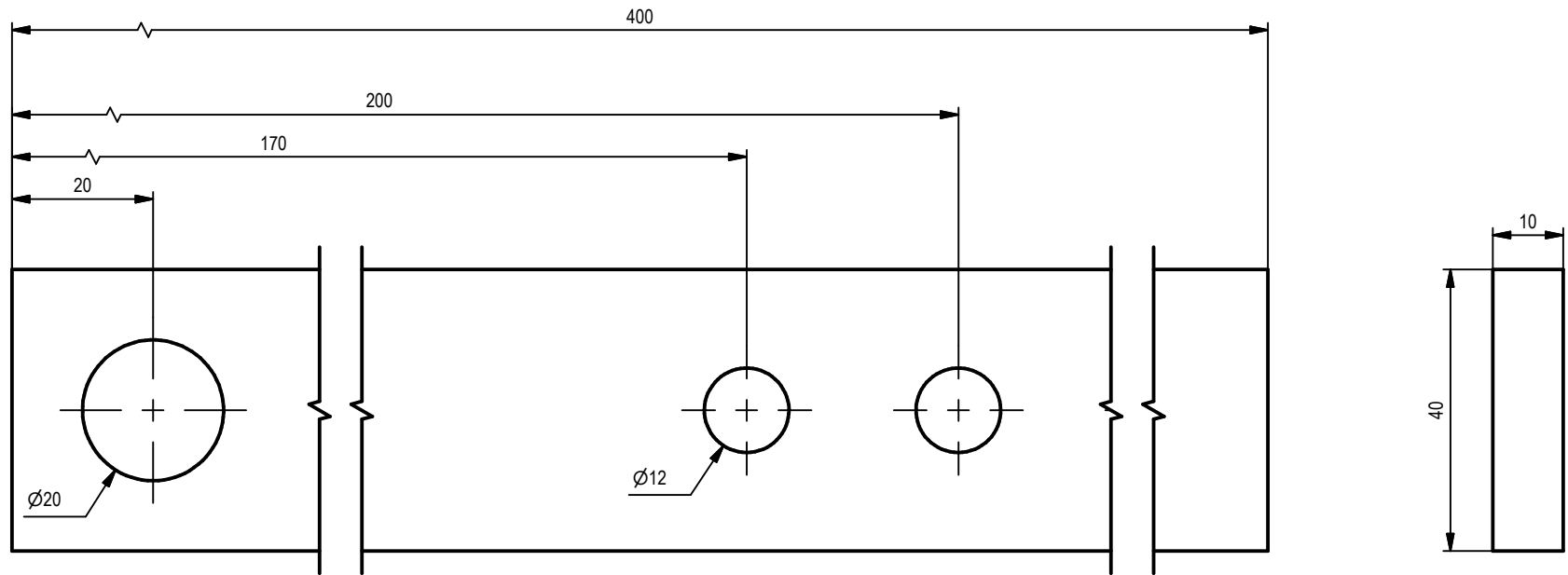
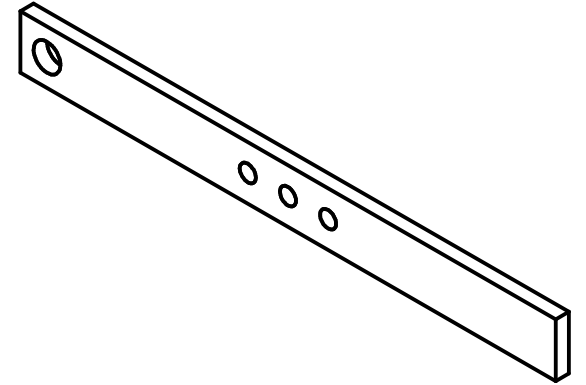

PROYECTO Dobladora de Tubos	CREADO POR A. PARDO	APROBADO POR D. Jaeger		
NOMBRE DE PIEZA FORMER SPACER	CÓDIGO 3.2	TIPO DE DOCUMENTO Production	MATERIAL Steel C45	
 Open Source Ecology e.V. Knobelsdorffstr. 22 14059 Berlin www.ose-germany.de +49 (0) 30 / 92282426	LICENCIA CERN-OHL	NOMBRE DE ARCHIVO FORMER SPACER.ipt	VERSIÓN 1.0	CANTIDAD 1
		ESCALA 1.5 : 1	HOJA 15	FECHA 26-10-2020



PROYECTO Dobladora de Tubos	CREADO POR A. PARDO	APROBADO POR D. Jaeger		
NOMBRE DE PIEZA HANDLE ARM	CÓDIGO 3.3	TIPO DE DOCUMENTO Production	MATERIAL Steel C45	
 Open Source Ecology e.V. Knobelsdorffstr. 22 14059 Berlin www.ose-germany.de +49 (0) 30 / 92282426	LICENCIA CERN-OHL	NOMBRE DE ARCHIVO HANDLE ARM.ipt	VERSIÓN 1.0	CANTIDAD 1
		ESCALA 1 : 1	HOJA 16	FECHA 26-10-2020

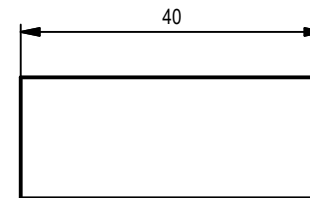
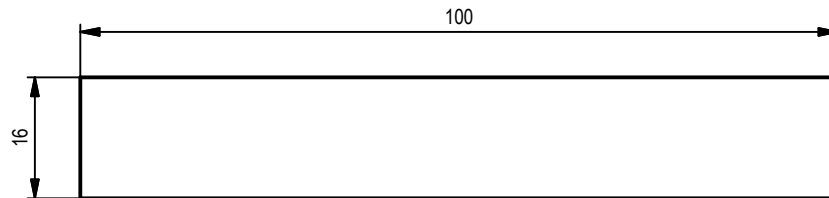
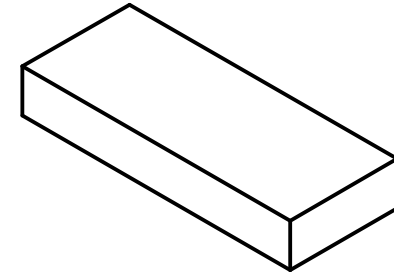

PROYECTO Dobladora de Tubos	CREADO POR A. PARDO	APROBADO POR D. Jaeger		
NOMBRE DE PIEZA HANDLE SPACER	CÓDIGO 3.4	TIPO DE DOCUMENTO Production	MATERIAL Steek C45	
 <p>Open Source Ecology e.V Knobelsdorffstr. 22 14059 Berlin www.ose-germany.de +49 (0) 30 / 92282426</p>	LICENCIA CERN-OHL	NOMBRE DE ARCHIVO HANDLE SPACER.ipt	VERSIÓN 1.0	CANTIDAD 1
		ESCALA 1 : 1	HOJA 17	FECHA 26-10-2020

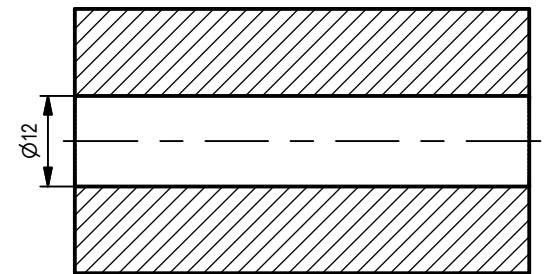
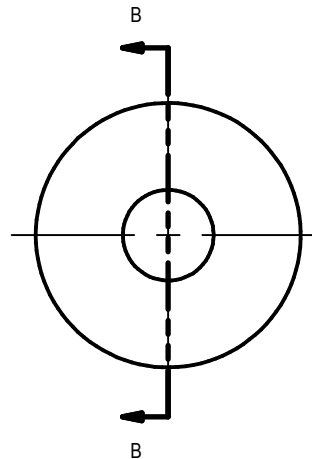
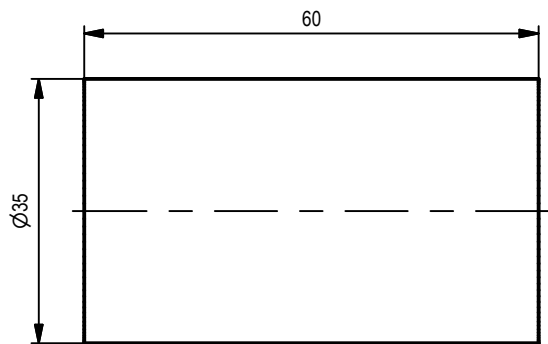

SECTION B-B
SCALE 1 : 1

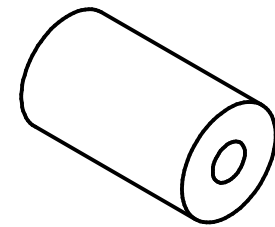

PROYECTO Dobladora de Tubos		CREADO POR A. PARDO		APROBADO POR D. Jaeger	
NOMBRE DE PIEZA ROLLER		CÓDIGO 3.5		TIPO DE DOCUMENTO Production	
 Open Source Ecology e.V. Knobelsdorffstr. 22 14059 Berlin www.ose-germany.de +49 (0) 30 / 92282426		LICENCIA CERN-OHL		NOMBRE DE ARCHIVO ROLLER.ipt	
		MATERIAL Steel C45		VERSIÓN 1.0	
		ESCALA 1 : 1		CANTIDAD 1	
		HOJA 18		FECHA 26-10-2020	

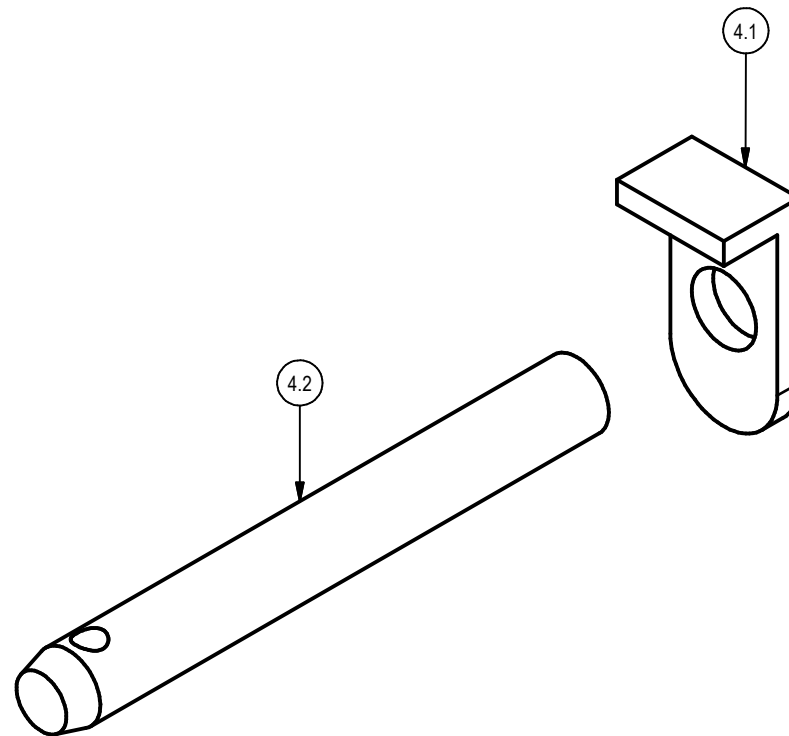

PROYECTO Dobladora de Tubos	CREADO POR A. PARDO	APROBADO POR D. Jaeger		
NOMBRE DE PIEZA ASSEMBLY	CÓDIGO 4	TIPO DE DOCUMENTO ASSEMBLY	MATERIAL Steel C45	
 <p>Open Source Ecology e.V Knobelsdorffstr. 22 14059 Berlin www.ose-germany.de +49 (0) 30 / 92282426</p>	LICENCIA CERN-OHL	NOMBRE DE ARCHIVO SUB-PIPE BENDING MACHINE 4.iam	VERSIÓN 1.0	CANTIDAD 1
		ESCALA 1 : 1	HOJA 19	FECHA 26-11-2020

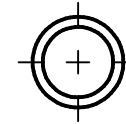
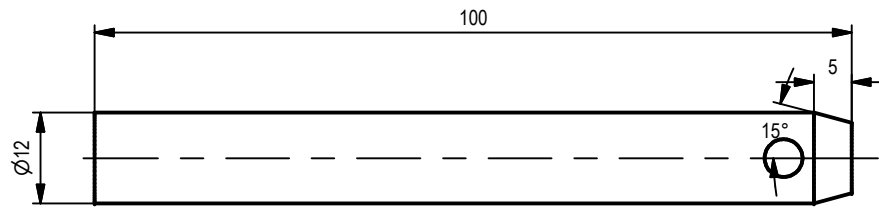
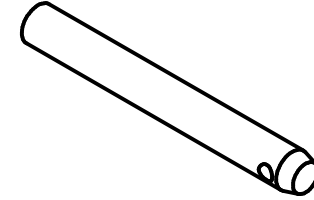

PROYECTO Dobladora de Tubos	CREADO POR A. PARDO	APROBADO POR D. Jaeger		
NOMBRE DE PIEZA ROLLER PIN	CÓDIGO 4.1	TIPO DE DOCUMENTO Production	MATERIAL Steel C45	
 <p>Open Source Ecology e.V Knobelsdorffstr. 22 14059 Berlin www.ose-germany.de +49 (0) 30 / 92282426</p>	LICENCIA CERN-OHL	NOMBRE DE ARCHIVO ROLLER PIN.ipt	VERSIÓN 1.0	CANTIDAD 1
		ESCALA 1 : 1	HOJA 20	FECHA 26-10-2020

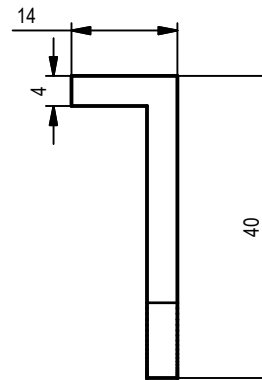
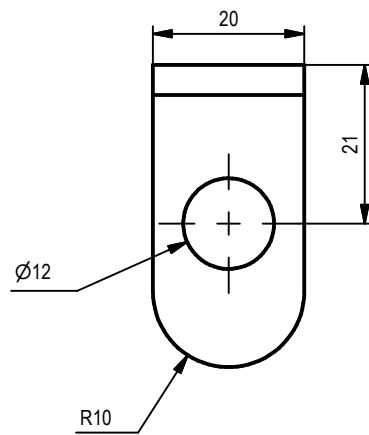
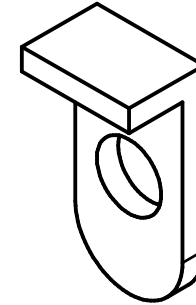

PROYECTO Dobladora de Tubos		CREADO POR A. PARDO		APROBADO POR D. Jaeger	
NOMBRE DE PIEZA PIN HANDLE		CÓDIGO 4.2		TIPO DE DOCUMENTO Production	
 Open Source Ecology e.V. Knobelsdorffstr. 22 14059 Berlin www.ose-germany.de +49 (0) 30 / 92282426		LICENCIA CERN-OHL		MATERIAL Steel C45	
		NOMBRE DE ARCHIVO PIN HANDLE.ipt		CANTIDAD 1	
		ESCALA 1 : 1		VERSIÓN 1.0	
				HOJA 21	
				FECHA 26-10-2020	

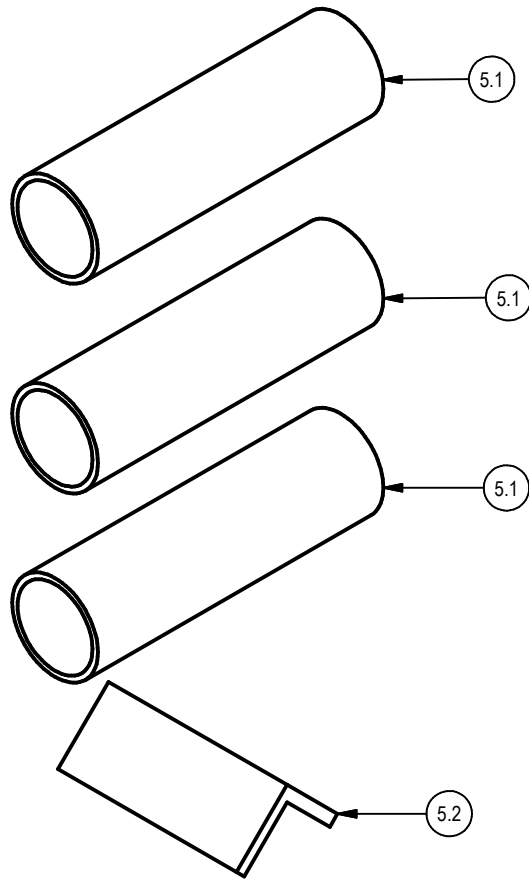

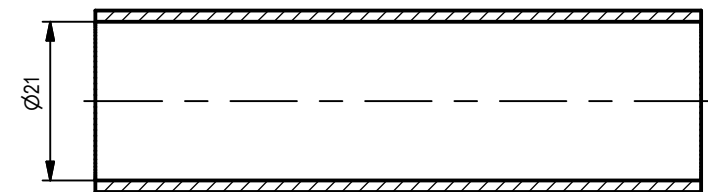
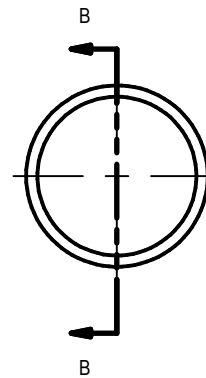
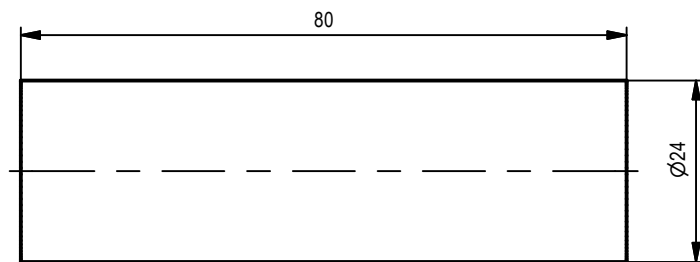
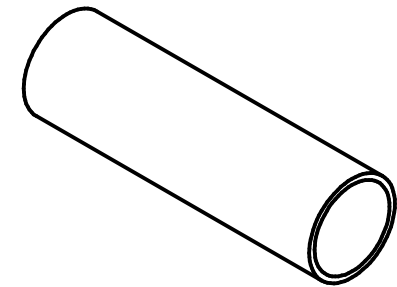

PROYECTO Dobladora de Tubos	CREADO POR A. PARDO	APROBADO POR D. Jaeger			
NOMBRE DE PIEZA ASSEMBLY	CÓDIGO 5	TIPO DE DOCUMENTO ASSEMBLY	MATERIAL Steel C45		
 <p>Open Source Ecology e.V Knobelsdorffstr. 22 14059 Berlin www.ose-germany.de +49 (0) 30 / 92282426</p>	LICENCIA CERN-OHL	NOMBRE DE ARCHIVO SUB-PIPE BENDING MACHINE 5.iam	VERSIÓN 1.0	CANTIDAD 1	
		ESCALA 1 / 1.5	HOJA 22	FECHA 26-11-2020	



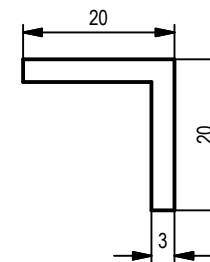
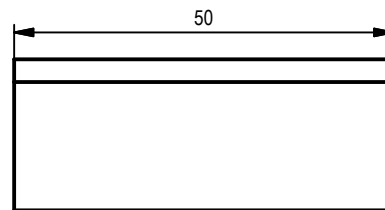
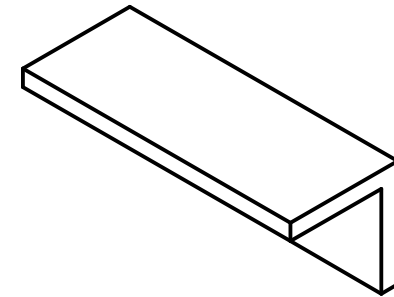

SECTION B-B
SCALE 1 : 1

PROYECTO Dobladora de Tubos	CREADO POR A. PARDO	APROBADO POR D. Jaeger		
NOMBRE DE PIEZA STOP TUBE	CÓDIGO 5.1	TIPO DE DOCUMENTO Production	MATERIAL Steel C45	
 <p>Open Source Ecology e.V Knobelsdorffstr. 22 14059 Berlin www.ose-germany.de +49 (0) 30 / 92282426</p>	LICENCIA CERN-OHL	NOMBRE DE ARCHIVO STOP TUBE.ipt	VERSIÓN 1.0	CANTIDAD 1
		ESCALA 1 : 1	HOJA 23	FECHA 26-10-2020

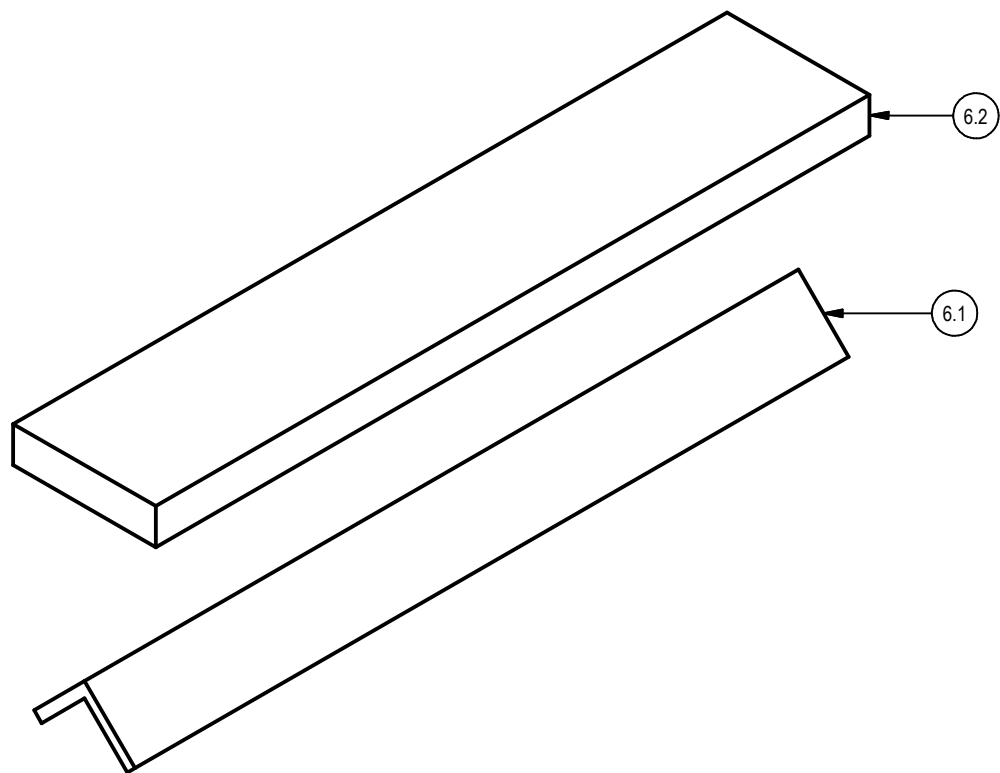

PROYECTO Dobladora de Tubos	CREADO POR A. PARDO	APROBADO POR D. Jaeger		
NOMBRE DE PIEZA STOP ANGLE	CÓDIGO 5.2	TIPO DE DOCUMENTO Production	MATERIAL Steel C45	
 <p>Open Source Ecology e.V Knobelsdorffstr. 22 14059 Berlin www.ose-germany.de +49 (0) 30 / 92282426</p>	LICENCIA CERN-OHL	NOMBRE DE ARCHIVO STOP ANGLE.ipt	VERSIÓN 1.0	CANTIDAD 1
		ESCALA 1 : 1	HOJA 24	FECHA 26-10-2020



PROYECTO Dobladora de Tubos	CREADO POR A. PARDO	APROBADO POR D. Jaeger			
NOMBRE DE PIEZA ASSEMBLY	CÓDIGO 6	TIPO DE DOCUMENTO ASSEMBLY	MATERIAL Steel C45		
 Open Source Ecology e.V. Knobelsdorffstr. 22 14059 Berlin www.ose-germany.de +49 (0) 30 / 92282426	LICENCIA CERN-OHL	NOMBRE DE ARCHIVO SUB-PIPE BENDING MACHINE 6.iam	VERSIÓN 1.0	CANTIDAD 1	
		ESCALA 1 / 1.5	HOJA 25	FECHA 26-11-2020	

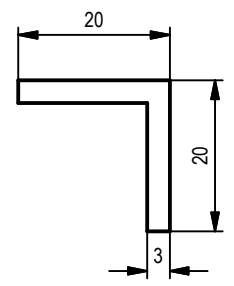
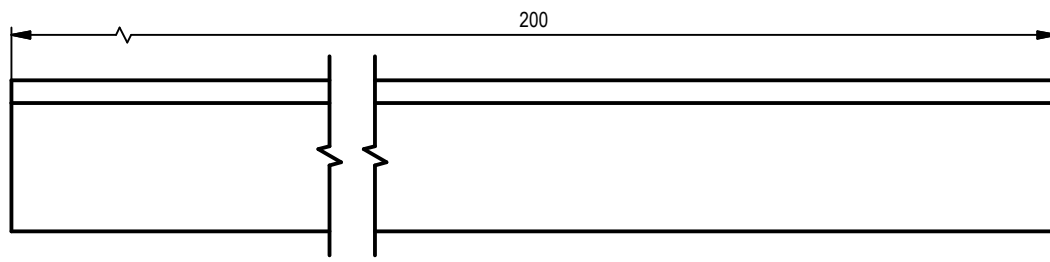
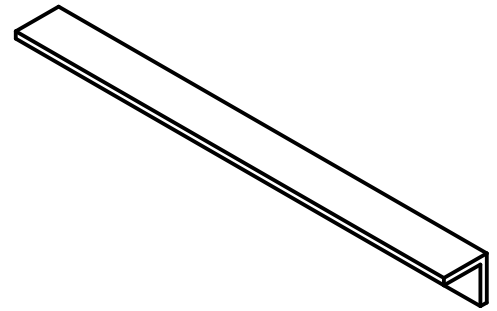

PROYECTO Dobladora de Tubos	CREADO POR A. PARDO	APROBADO POR D. Jaeger		
NOMBRE DE PIEZA GUIDE ANGLE	CÓDIGO 6.1	TIPO DE DOCUMENTO Production	MATERIAL Steel C45	
 <p>Open Source Ecology e.V Knobelsdorffstr. 22 14059 Berlin www.ose-germany.de +49 (0) 30 / 92282426</p>	LICENCIA CERN-OHL	NOMBRE DE ARCHIVO GUIDE ANGLE.ipt	VERSIÓN 1.0	CANTIDAD 1
		ESCALA 1 : 1	HOJA 26	FECHA 26-10-2020

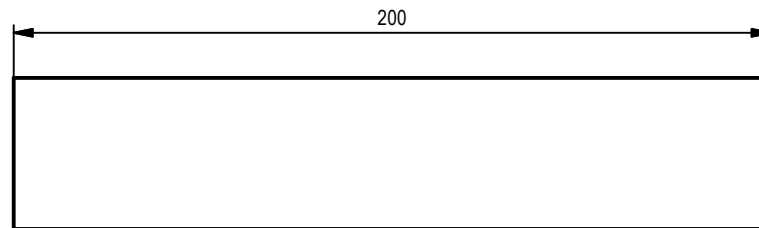
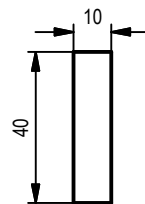
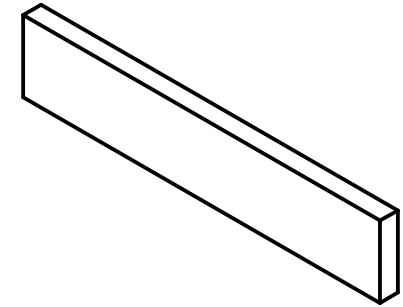

PROYECTO Dobladora de Tubos	CREADO POR A. PARDO	APROBADO POR D. Jaeger		
NOMBRE DE PIEZA GUIDE BASE	CÓDIGO 6.2	TIPO DE DOCUMENTO Production	MATERIAL Steel C45	
 Open Source Ecology e.V. Knobelsdorffstr. 22 14059 Berlin www.ose-germany.de +49 (0) 30 / 92282426	LICENCIA CERN-OHL	NOMBRE DE ARCHIVO GUIDE BASE.ipt	VERSIÓN 1.0	CANTIDAD 1
		ESCALA 1 / 2	HOJA 27	FECHA 26-10-2020

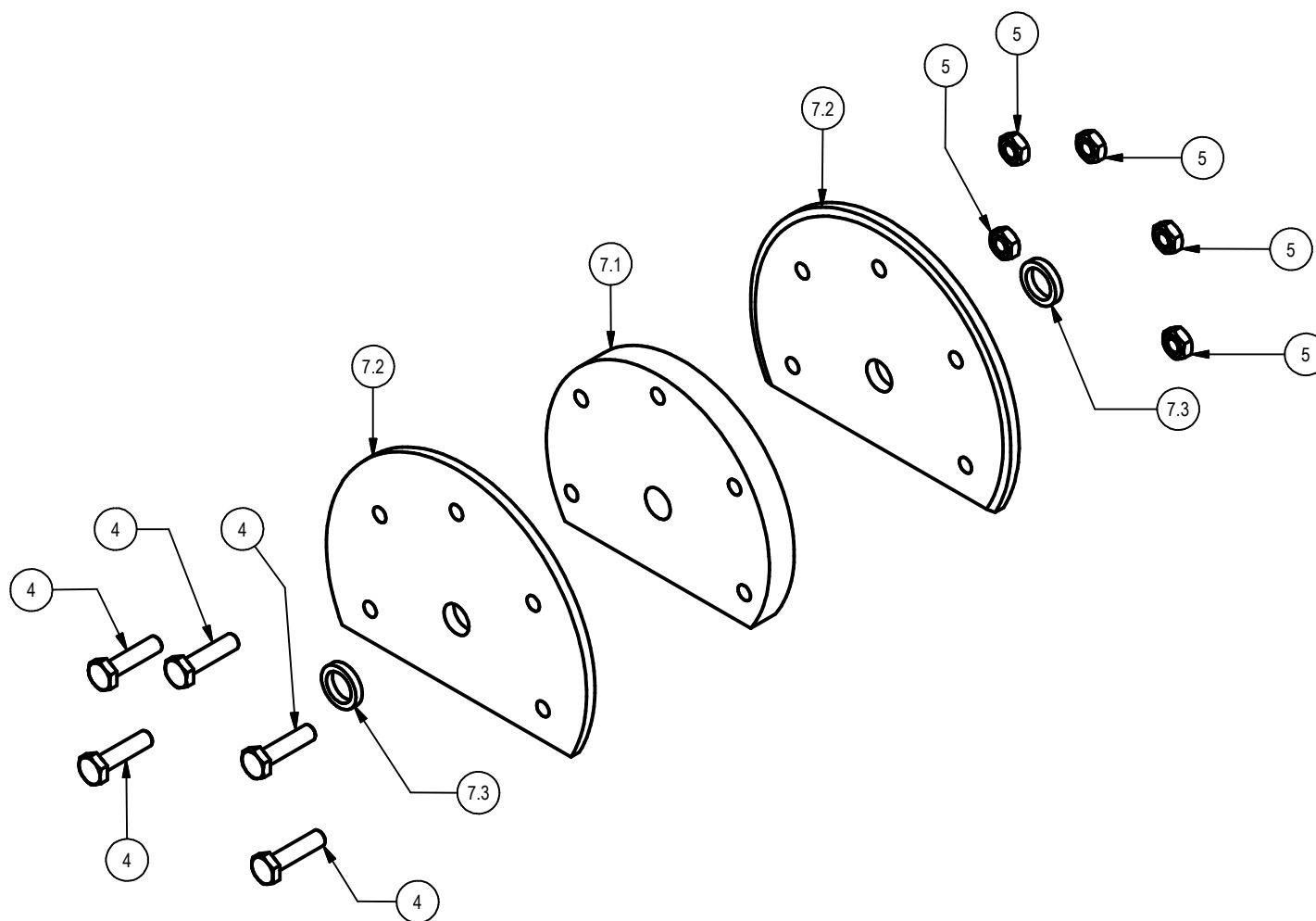

PROYECTO Dobladora de Tubos	CREADO POR A. PARDO	APROBADO POR D. Jaeger		
NOMBRE DE PIEZA ASSEMBLY	CÓDIGO 7	TIPO DE DOCUMENTO ASSEMBLY	MATERIAL Steel C45	
 Open Source Ecology e.V. Knobelsdorffstr. 22 14059 Berlin www.ose-germany.de +49 (0) 30 / 92282426	LICENCIA CERN-OHL	NOMBRE DE ARCHIVO SUB-PIPE BENDING MACHINE 7.iam	VERSIÓN 1.0	CANTIDAD 1
		ESCALA 1 / 4	HOJA 28	FECHA 26-11-2020

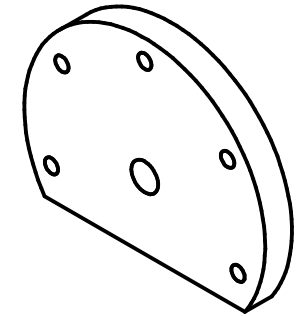
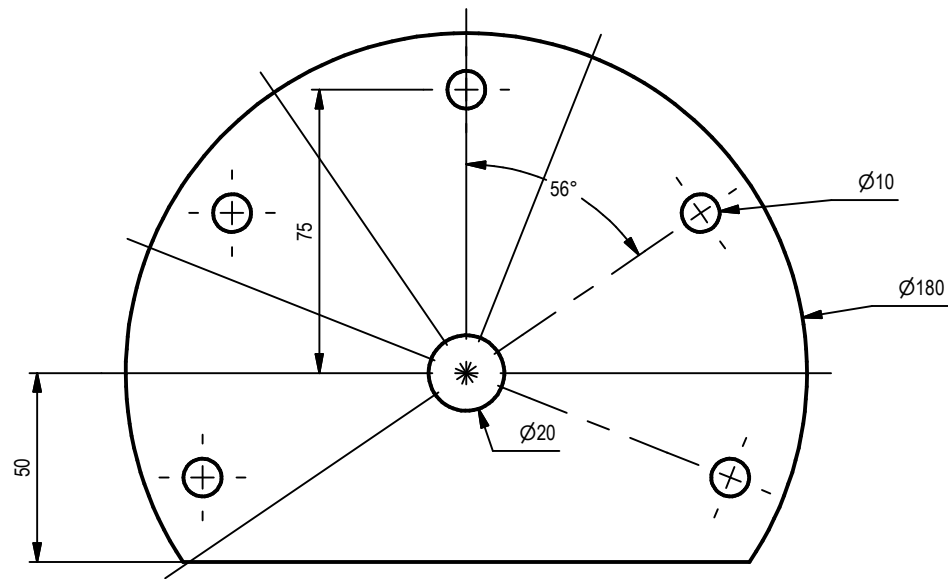

PROYECTO Dobladora de Tubos	CREADO POR A. PARDO	APROBADO POR D. Jaeger		
NOMBRE DE PIEZA FORMER SIDE	CÓDIGO 7.1	TIPO DE DOCUMENTO Production	MATERIAL Steel C45	
 <p>Open Source Ecology e.V Knobelsdorffstr. 22 14059 Berlin www.ose-germany.de +49 (0) 30 / 92282426</p>	LICENCIA CERN-OHL	NOMBRE DE ARCHIVO FORMER BASE.ipt	VERSIÓN 1.0	CANTIDAD 1
		ESCALA 1 / 2	HOJA 29	FECHA 26-10-2020

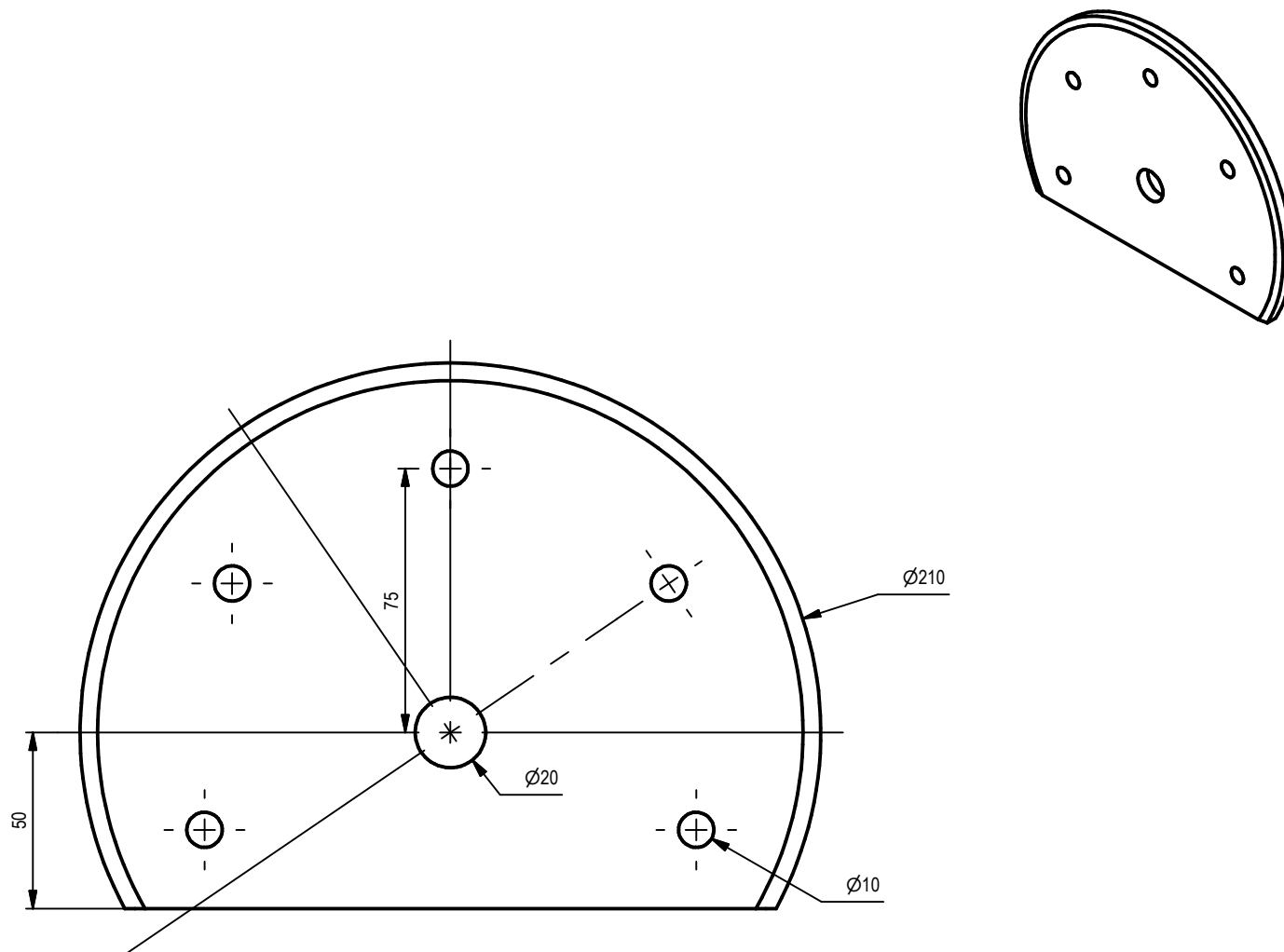
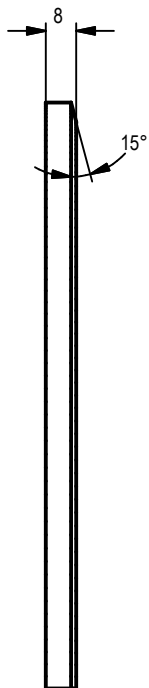

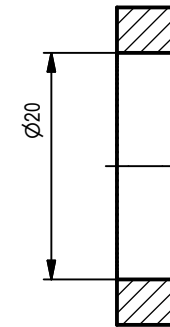
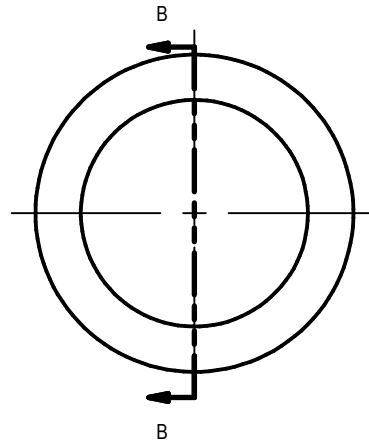
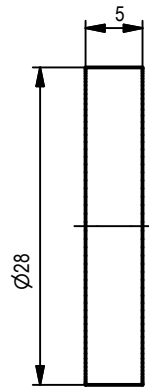
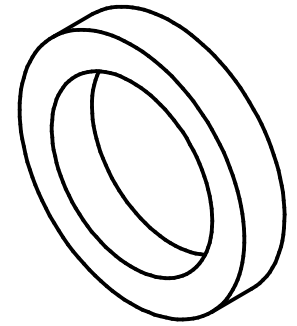

PROYECTO Dobladora de Tubos	CREADO POR A. PARDO	APROBADO POR D. Jaeger		
NOMBRE DE PIEZA FORMER SIDE	CÓDIGO 7.2	TIPO DE DOCUMENTO Production	MATERIAL Steel C45	
 Open Source Ecology e.V. Knobelsdorffstr. 22 14059 Berlin www.ose-germany.de +49 (0) 30 / 92282426	LICENCIA CERN-OHL	NOMBRE DE ARCHIVO FORMER SIDE.ipt	VERSIÓN 1.0	CANTIDAD 1
		ESCALA 1 / 2	HOJA 30	FECHA 26-10-2020

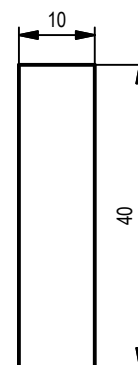
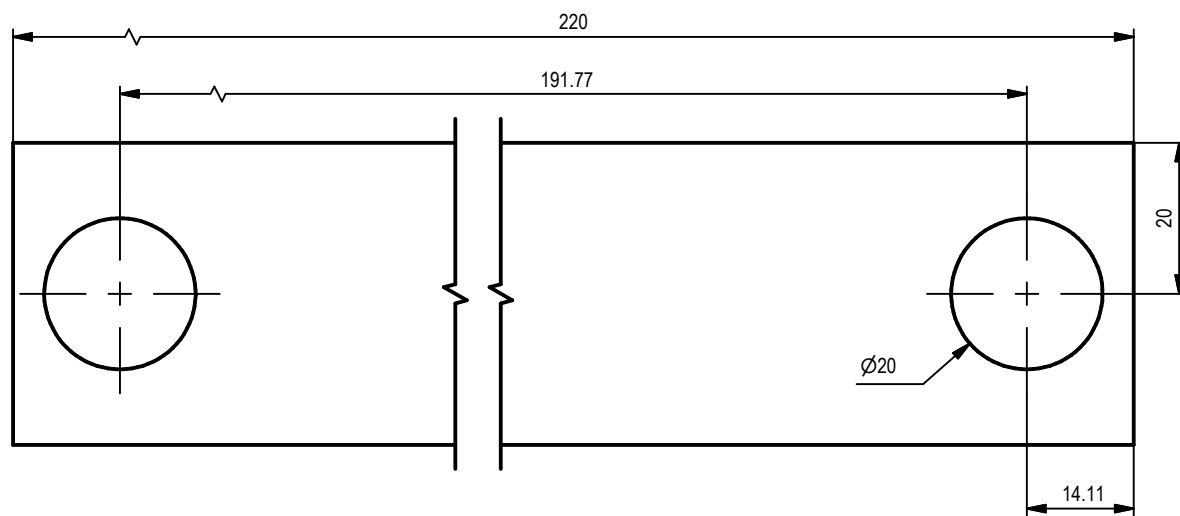
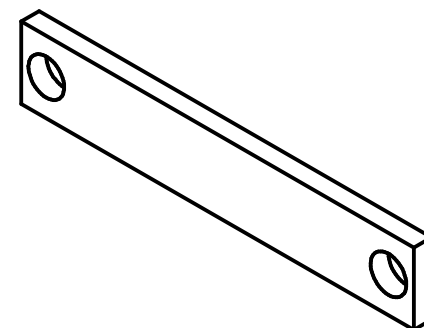

SECTION B-B
SCALE 1.5: 1

PROYECTO Dobladora de Tubos	CREADO POR A. PARDO	APROBADO POR D. Jaeger		
NOMBRE DE PIEZA SPACER TUBE	CÓDIGO 7.3	TIPO DE DOCUMENTO Production	MATERIAL Steel C45	
 Open Source Ecology e.V. Knobelsdorffstr. 22 14059 Berlin www.ose-germany.de +49 (0) 30 / 92282426	LICENCIA CERN-OHL	NOMBRE DE ARCHIVO SPACER TUBE.ipt	VERSIÓN 1.0	CANTIDAD 1
		ESCALA 1.5: 1	HOJA 31	FECHA 26-10-2020



PROYECTO Dobladora de Tubos		CREADO POR A. PARDO		APROBADO POR D. Jaeger	
NOMBRE DE PIEZA PIN LINK		CÓDIGO 7.4		TIPO DE DOCUMENTO Production	
 Open Source Ecology e.V. Knobelsdorffstr. 22 14059 Berlin www.ose-germany.de +49 (0) 30 / 92282426		LICENCIA CERN-OHL		NOMBRE DE ARCHIVO PIN LINK.ipt	
		VERSIÓN 1.0		CANTIDAD 1	
		ESCALA 1 : 1		HOJA 32	
				FECHA 26-10-2020	