

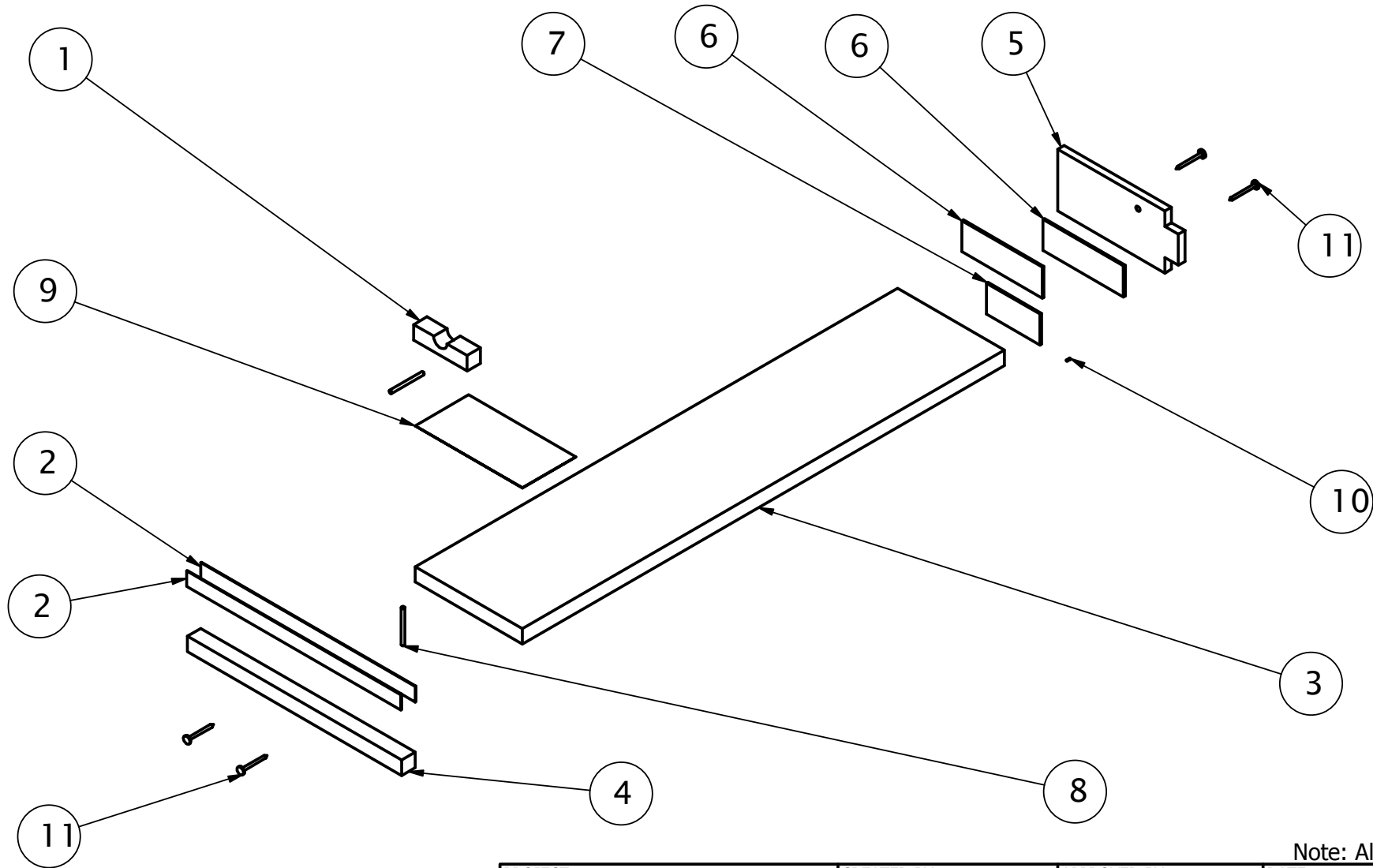

Note: All units in mm.

PROJECT	CREATED BY	APPROVED BY	DATE	VERSION
Optical Micrometer	E. Ceballos	A. Morillo	11-06-2021	1.0
PART NAME	FILE NAME			POS
3d views	optical micrometer.iam			A1
DEVELOPED BY	REDESIGNED BY	DOC. TYPE	MATERIAL	QUANTITY
		Assembly		1
AMERICAN PEACE CORPS	OHO e.V.	LICENCE	SCALE	SHEET
		CC-BY-SA 4.0	1:5	1 / 7



Note: All units in mm.

PROJECT	CREATED BY	APPROVED BY	DATE	VERSION
Optical Micrometer	E. Ceballos	A. Morillo	11-06-2021	1.0
PART NAME	FILE NAME	POS		
Exploded 3d view	optical micromter.ipn	A2		
DEVELOPED BY	REDESIGNED BY	DOC. TYPE	MATERIAL	QUANTITY
		Assembly		1
AMERICAN PEACE CORPS	OHO e.V.	LICENCE	SCALE	SHEET
		CC-BY-SA 4.0	1:4	2 / 7

Parts list

POS	QTY	PART NAME	FILE NAME	PART TYPE	SPECIFICATIONS	SHEET
A1	1	3d views	optical micrometer.iam			1
A2		Exploded 3d view	optical micrometer.ipn			2
B1		Parts list	part list.csv			3
1	1	sliding block	sliding block.ipt	Production	wood, kiln-dried pine	4
2	2	strapping	strapping.ipt	Buy	steel, ASTM 1045 / DIN C45, 0,75 x 12,7 x 203 mmm	
3	1	18 in board	18 in block.ipt	Production	wood, kiln-dried pine	5
4	1	8 in board	8 in block.ipt	Production	wood, kiln-dried pine	6
5	1	1/4" in board	1_4 in block.ipt	Production	wood, kiln-dried pine	7
6	2	object carrier	object carrier.ipt	Buy	glass, 1" x 3"	
7	1	mirror	mirror.ipt	Buy	mirror, 1" x 2"	
8	2	1 1/4 " nail	1_25 in nail.ipt	Buy	steel, ASTM F-1667	
9	1	crumpled paper	crumpled paper.ipt	Buy	paper	
10	1	elastic	elastic.ipt	Buy	rupper	
11	4	1" nail	nail.ipt	Buy	steel, ASTM F.1667	

PROJECT		CREATED BY		APPROVED BY		DATE		VERSION	
Optical Micrometer		E. Ceballos		A. Morillo		11-06-2021		1.0	
PART NAME			FILE NAME					POS	
Parts list			part list.csv					B1	
DEVELOPED BY			REDESIGNED BY		DOC. TYPE		MATERIAL		QUANTITY
					Parts list				
AMERICAN PEACE CORPS			OHO e.V.		LICENCE		SCALE		SHEET
					CC-BY-SA 4.0				3 /7

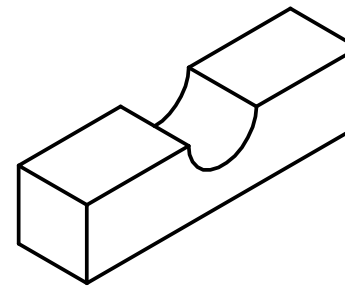
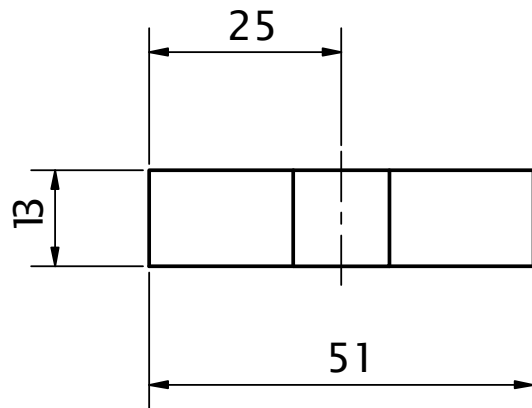
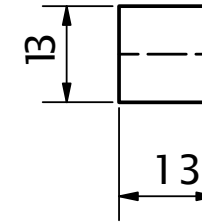
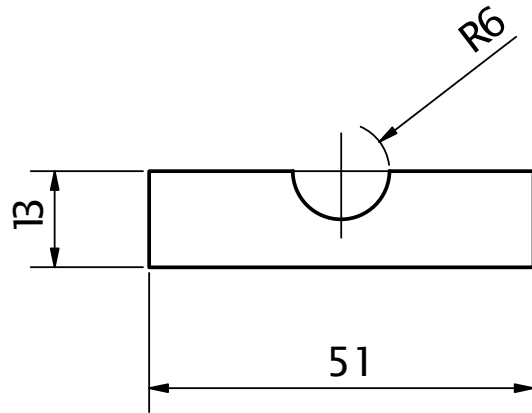

Note: All units in mm.

PROJECT	CREATED BY	APPROVED BY	DATE	VERSION
Optical Micrometer	E. Ceballos	A. Morillo	11-06-2021	1.0
PART NAME	FILE NAME	POS		
sliding block	sliding block.ipt	1		
DEVELOPED BY	REDESIGNED BY	DOC. TYPE	MATERIAL	QUANTITY
		Assembly	kiln-dired pine	1
AMERICAN PEACE CORPS	OHO e.V.	LICENCE	SCALE	SHEET
		CC-BY-SA 4.0	1:1	4 / 7

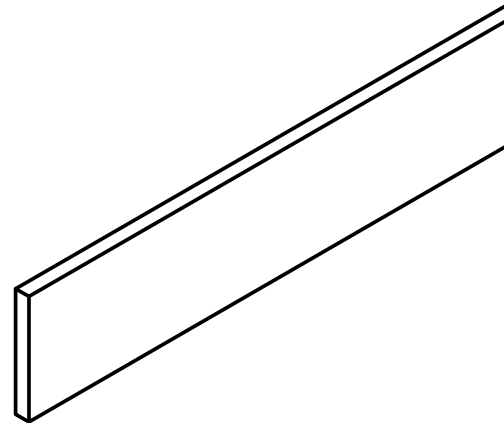
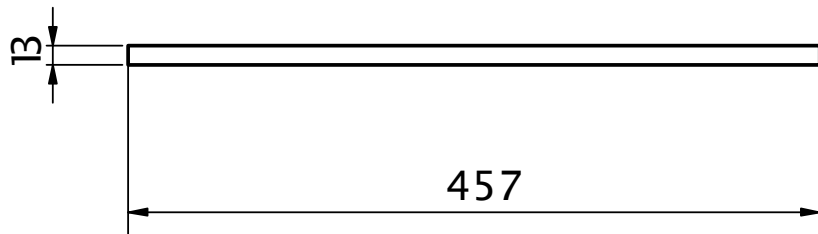
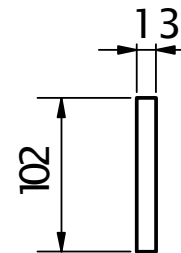
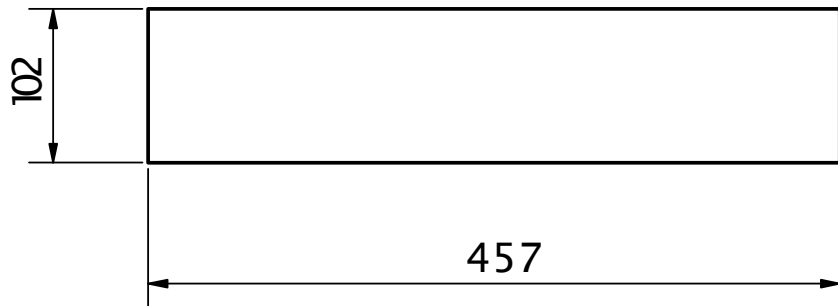

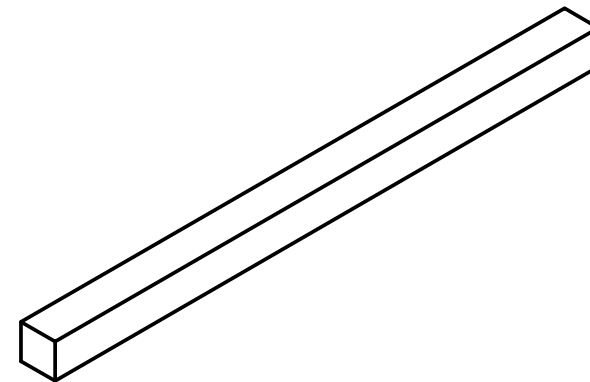
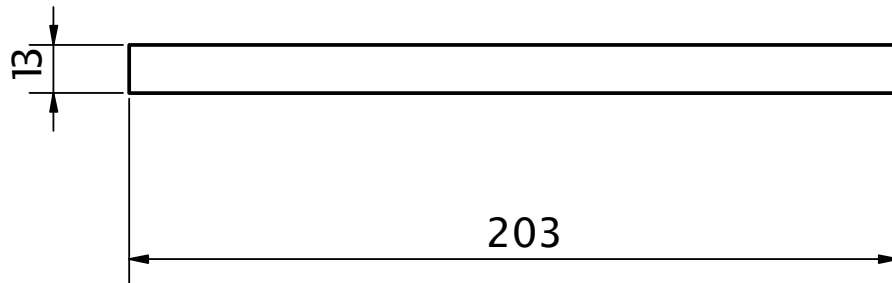
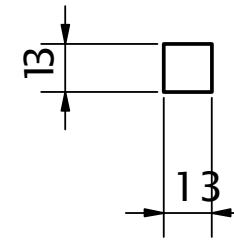
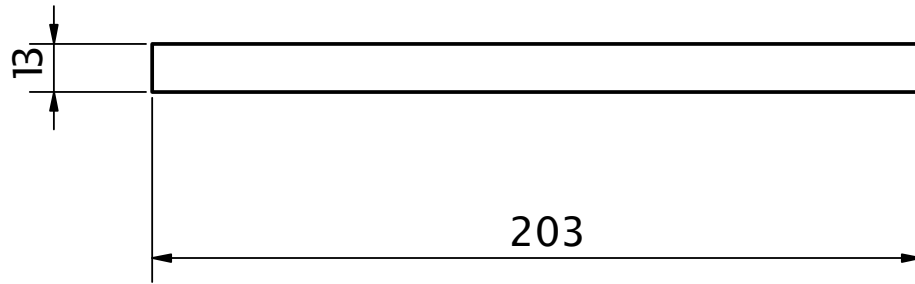

Note: All units in mm.

PROJECT	CREATED BY	APPROVED BY	DATE	VERSION
Optical Micrometer	E. Ceballos	A. Morillo	11-06-2021	1.0
PART NAME	FILE NAME			POS
18 " board	18 in block.ipt			3
DEVELOPED BY	REDESIGNED BY	DOC. TYPE	MATERIAL	QUANTITY
		Part	wood, kiln-dried pine	1
AMERICAN PEACE CORPS	OHO e.V.	LICENCE	SCALE	SHEET
		CC-BY-SA 4.0	1:1	5 / 7

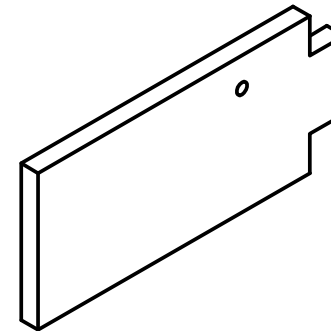
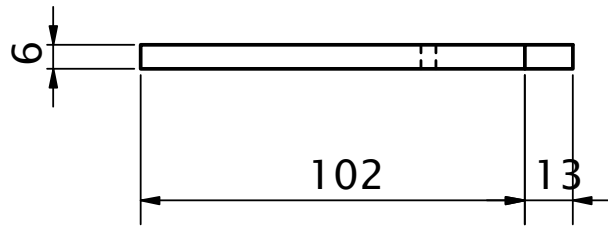
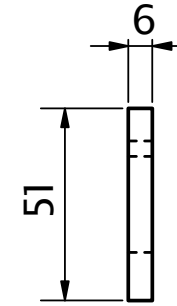
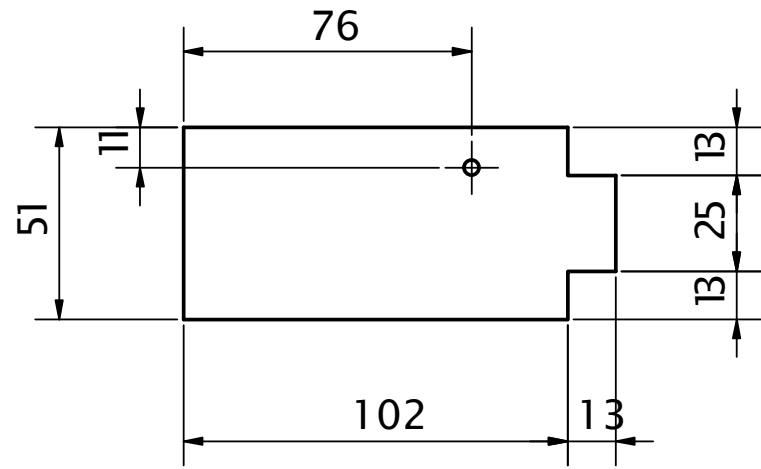

PROJECT	CREATED BY	APPROVED BY	DATE	VERSION
Optical Micrometer	E. Ceballos	A. Morillo	11-06-2021	1.0
PART NAME	FILE NAME			POS
8" board	8 in block.ipt			4
DEVELOPED BY	REDESIGNED BY	DOC. TYPE	MATERIAL	QUANTITY
		PART	wood, kin-dried pine	1
AMERICAN PEACE CORPS	OHO e.V.	LICENCE	SCALE	SHEET
		CC-BY-SA 4.0	1:2	6 / 7



PROJECT	CREATED BY	APPROVED BY	DATE	VERSION
Optical Micrometer	E. Ceballos	A. Morillo	11-06-2021	1.0
PART NAME	FILE NAME			POS
1/4" board	1_4 in block.ipt			5
DEVELOPED BY	REDESIGNED BY	DOC. TYPE	MATERIAL	QUANTITY
		PART	wood, kiln-dried pine	1
AMERICAN PEACE CORPS	OHO e.V.	LICENCE	SCALE	SHEET
		CC-BY-SA 4.0	1:2	7 / 7