

2



1

D

D



C

C

B

B



<b>PROJEKT</b> Windmuehlen-Pumpe		ERSTELLT VON D. Mosquera	GENEHMIGT VON D. Jaeger		
<b>TEIL-NAME</b> Wind Mill Pump		TEIL-CODE A1	DOKUMENTTYP ASSEMBLY	WERKSTOFF	
UMGESTALTET VON  OPEN SOURCE ECOLOGY GERMANY	UNTERSTÜTZT VON  STIFTUNG	LIZENZ CC BY-SA 4.0	DATEI-NAME oseg_wmp_A1_wind-mill-pump..iam	VERSION 1.0	MENGE
			SCALE 1 / 22	SEITE 1	DATE 28.02.21

A

A

2



1

2

1

D

D

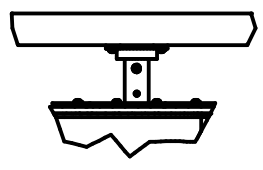

DETAIL 1

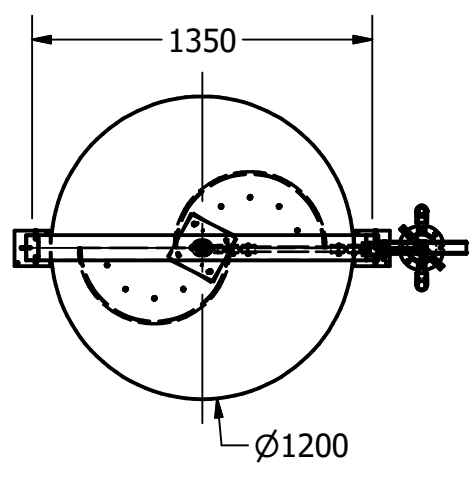

C

C

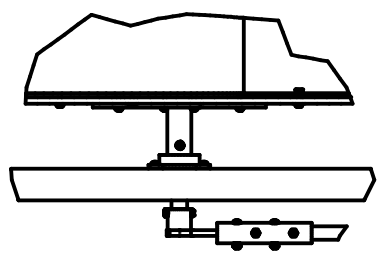

DETAIL 2

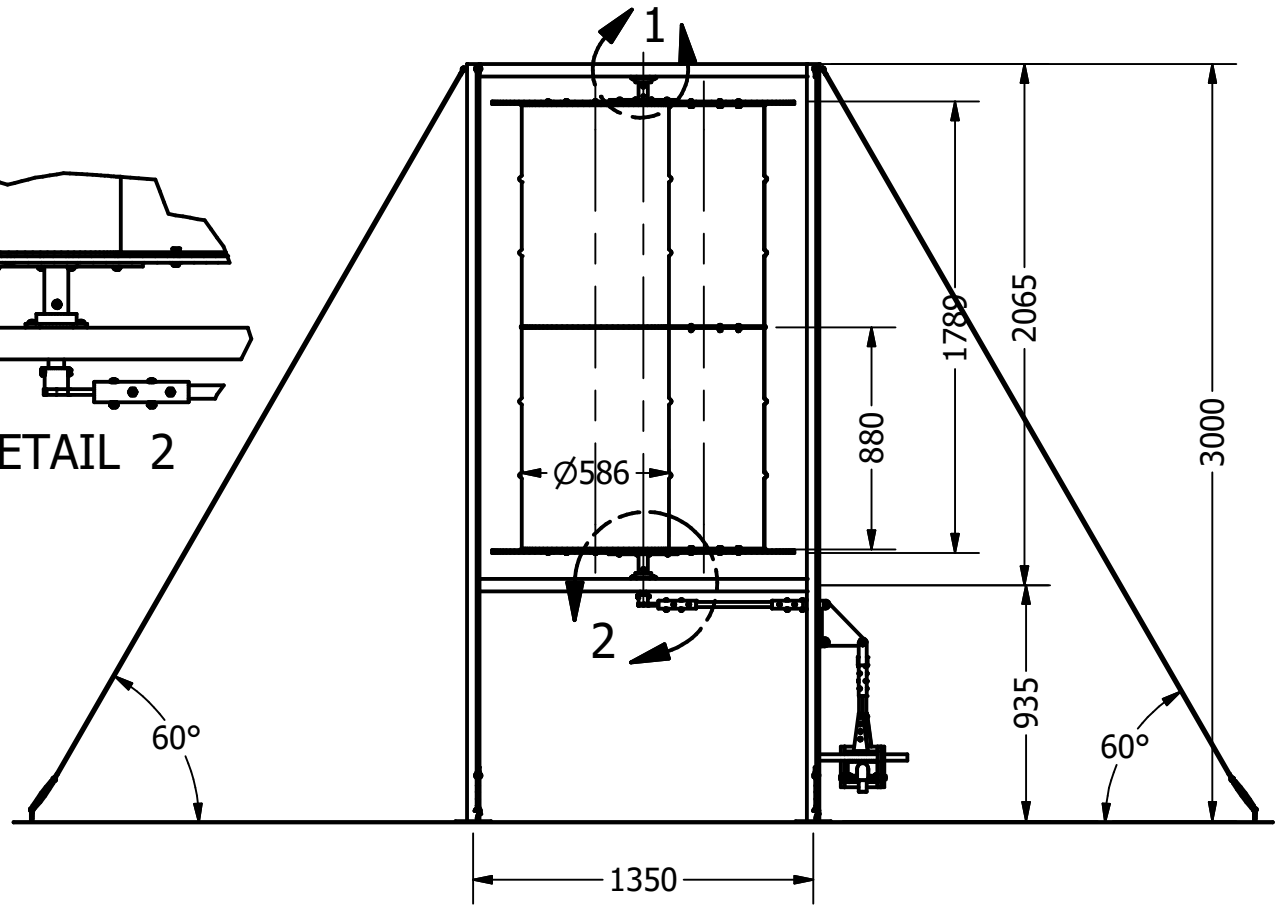



B

B

A

A



<b>PROJEKT</b> Windmuehlen-Pumpe		<b>ERSTELLT VON</b> D. Mosquera		<b>GENEHMIGT VON</b> D. Jaeger	
<b>TEIL-NAME</b> Wind Mill Pump		<b>TEIL-CODE</b> A1		<b>DOKUMENTTYP</b> ASSEMBLY	
<b>UMGESTALTET VON</b> 		<b>UNTERSTÜTZT VON</b> 		<b>VERSION</b> 1.0	
<b>LIZENZ</b> CC BY-SA 4.0		<b>DATEI-NAME</b> oseg_wmp_A1_wind-mill-pump..iam		<b>MENGE</b>	
		<b>SCALE</b> 1 / 30		<b>SEITE</b> 2	
				<b>DATE</b> 28.02.21	

2

1

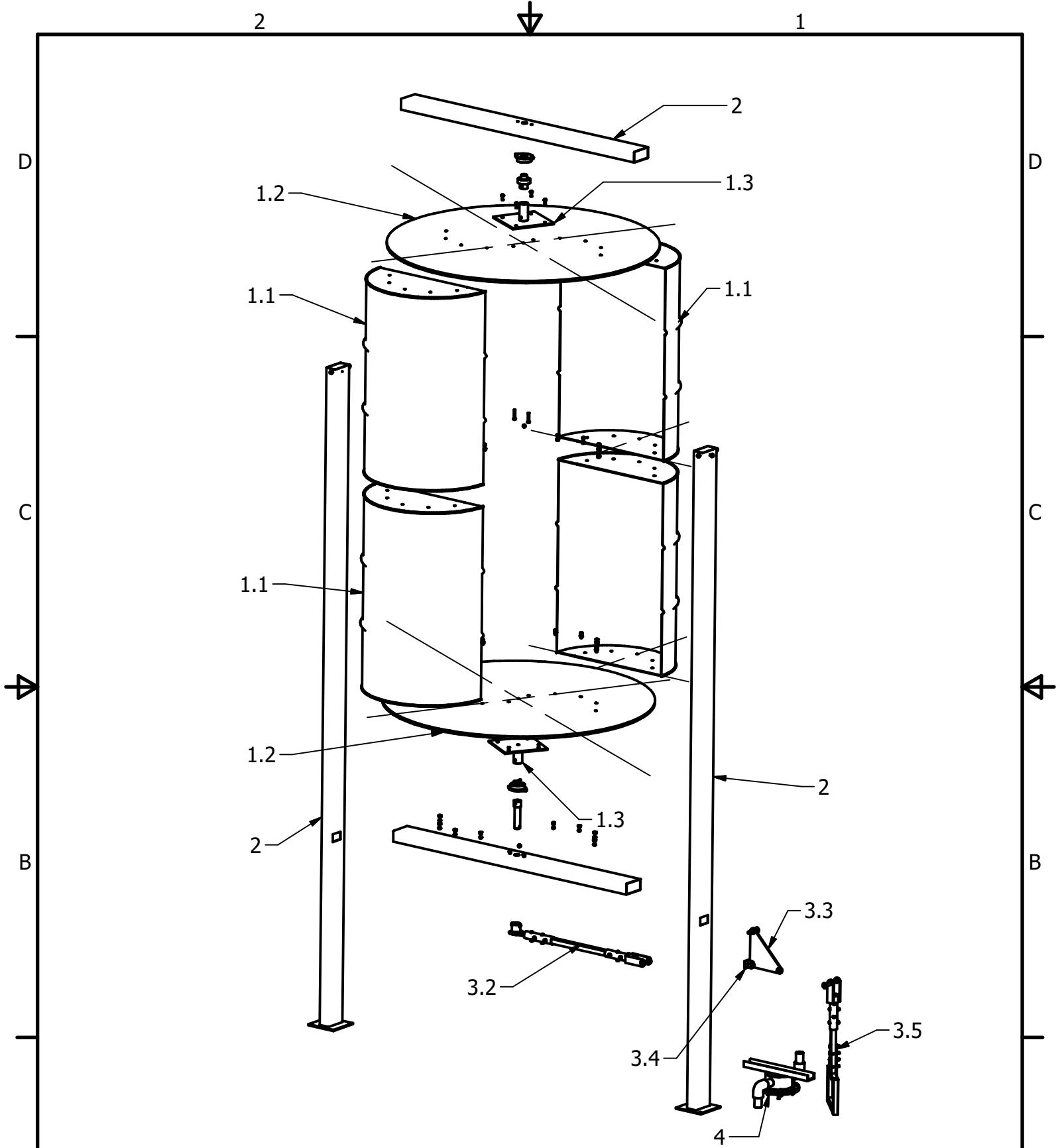



<b>PROJEKT</b> Windmuehlen-Pumpe		<b>ERSTELLT VON</b> D. Mosquera		<b>GENEHMIGT VON</b> D. Jaeger	
<b>TEIL-NAME</b> Wind Mill Pump		<b>TEIL-CODE</b> A1		<b>DOKUMENTTYP</b> ASSEMBLY	
<b>UMGESTALTET VON</b>		<b>UNTERSTÜTZT VON</b>		<b>VERSION</b>	
 OPEN SOURCE ECOLOGY GERMANY		 STIFTUNG		1.0	
<b>LIZENZ</b> CC BY-SA 4.0		<b>DATEI-NAME</b> oseg_wmp_A1_wind-mill-pump.iam		<b>MENGE</b>	
				SCALE 1 / 22	
				SEITE 3	
				DATE 28.02.21	

2



1



2



1

Pos.	Pos. old	CA	TEIL NAME	DATEI-NAME	TEIL-TYP	SPEZIFIKAT	SE
A			Windmühlenpumpe	oseg_wmp_A1_wind-mill-pump.iam	Production		1-2
			Windmühlenpumpe		Assembly		3
D			Teileliste	oseg_wmp_B_wind-mill-pump-parts-list.xls	parts list		4
1	1		Der Rotor	oseg_wmp_The-Rotor.iam	Production		7
1.1	2	4	1/2 Ölfass	oseg_wmp_1-2-oil-drum.ipt	Production	200-Liter-Fass 867 Höhe x 584 Durchmesser	9
1.2		2	Platten aus Sperrholz	oseg_wmp_plates-plywood.ipt	Production	Sperrholz	10
1.3	3	2	Flanschstütze	oseg_wmp_flange-support.ipt	Production	Baustahl A36	11
1.4		2	Rotorwelle	oseg_wmp_rotor-shaft.ipt	Production	Stahl C45	12
2	6		Rahmen	oseg_wmp_frame.iam	Production		13
2.1		2	Stützlatten 50x25x3000	oseg_wmp_supporting-laths-50x25x3000.ipt	Standard	Baustahl A36	15
C		2	Stützlatten 50x25x1300	oseg_wmp_supporting-laths-50x25x1300.ipt	Standard	Baustahl A36	16
2.3	4	1	oberer Adapter	oseg_wmp_top-adaptor.ipt	Production	Stahl C45	17
2.4	4	1	unterer Adapter	oseg_wmp_bottom-adaptor.ipt	Production	Stahl C45	18
2.5		2	selbstaushwuchtendes Lager	oseg_wmp_self-aligning-bearing.ipt	Standard	Lager 6205 - 25x56x15	
2.6		2	Lagerhalterung	oseg_wmp_bearing-support.ipt	Production	Stahl C45	19
➔		2	Rechteckige Flansche	oseg_wmp_rectangular-flancher.ipt	Production	Stahl C45	20
2.8		3	Sicherungsschraube	oseg_wmp_securing-bolt.ipt	Standard	Rundkopfschraube, verzinkter Stahl	
2.9		3	Sicherungsmutter	oseg_wmp_securing-nut.ipt	Standard	verzinkter Stahl	
B	7		Antrieb	oseg_wmp_drive.iam	Production		21
3.1		1	Exzentrisch	oseg_wmp_Excentric.ipt	Production	Stahl C45	22



<b>PROJEKT</b> Windmuehlen-Pumpe		ERSTELLT VON D. Mosquera		GENEHMIGT VON D. Jaeger	
<b>TEIL-NAME</b> Wind Mill Pump Part list		TEIL-CODE B1		DOKUMENTTYP Part list	
UMGESTALTET VON 		UNTERSTÜTZT VON 		LIZENZ CC BY-SA 4.0	
		DATEI-NAME Wind mill pump parts list 1.1.xls		VERSION 1.0	
		SCALE		MENGE	
				SEITE 4	
				DATE 28.02.21	

2



1



2



1

Pos.	Pos. old	CA	TEIL NAME	DATEI-NAME	TEIL-TYP	SPEZIFIKAT	SE
3.2	8b-8c		horizontale Pleuelstange	oseg_wmp_horizontal-connecting-rod.iam	Production		23
3.2.1	8c		Pleuelstange	oseg_wmp_connecting-rod.ipt	Standard	Pleuelstange eines Motorrad- oder Kleinwagenmotor	24
3.2.2		2	Wasserrohr 1 "x150	oseg_wmp_water-pipe-1x150.ipt	Production	verzinktes Rohr 1"	25
3.2.3			Stange horizontal 1x1x 600	oseg_wmp_rod-horizont-1x1x600.ipt	Production	Holzleiste	26
3.2.4		1	Nippel 1"	oseg_wmp_nipple-1.ipt	Standard	verzinktes Rohr 1" Fitting	
3.2.5		2	Halterung aus Blech	oseg_wmp_sides-plank.ipt	Production	Stahl C45	27
3.3	9		Umlenkhebel	oseg_wmp_bell-crank.ipt	Production	Stahl C45	28
3.4			Schwenkplatte	oseg_wmp_pivot-plate.ipt	Production	Stahlblech C45	29
3.5	8a		verstellbare Pumpstange Gabelkopf	oseg_wmp_adjustable-pumprod-forkend.iam	Production		30
3.5.1		2	Halterung aus Blech	oseg_wmp_sides-plank.ipt	Production	Stahlblech C45	32
3.5.2		1	Nippel 1"	oseg_wmp_nipple-1.ipt	Standard	verzinktes Rohr 1" Fitting	
3.5.3		1	Wasserrohr 1 "x150	oseg_wmp_water-pipe-1x150.ipt	Production	verzinktes Rohr 1"	33
3.5.4		1	Stange vert 1x1x 600	oseg_wmp_rod-vert-1x1x600.ipt	Production	Holzstreifen	34
3.5.5	8b	1	Bügel	oseg_wmp_stirrup.ipt	Production	Baustahl A36	35
3.5.6		2	Bügel aus Blech	oseg_wmp_sheet-metal-bracket.ipt	Production		36
3.6		16	Bolzen M6x30	oseg_wmp_bolts-M6x30.ipt	Standard	Rundkopfschraube, verzinkter Stahl	
3.7		16	Mutter M6	oseg_wmp_nut-M6.ipt	Standard	verzinkter Stahl	

A

<b>PROJEKT</b> Windmuehlen-Pumpe		ERSTELLT VON D. Mosquera		GENEHMIGT VON D. Jaeger	
<b>TEIL-NAME</b> Wind Mill Pump Part list		TEIL-CODE B1		DOKUMENTTYP Part list	
UMGESTALTET VON 		UNTERSTÜTZT VON 		LIZENZ CC BY-SA 4.0	
				DATEI-NAME Wind mill pump parts list 1.1.xls	
				VERSION 1.0	
				MENGE	
				SCALE	
				SEITE 5	
				DATE 28.02.21	

2



1



2



1

Pos.	Pos. old	CA	TEIL NAME	DATEI-NAME	TEIL-TYP	SPEZIFIKAT	SE
4	10	1	Pumpe	oseg_wmp_pump.iam	Production		37
4.1		1	Pumpenkörper O-Ring	oseg_wmp_pumpbody-oring.ipt	Production	Stahl C45	39
4.2		1	Pumpenkörperscheibe	oseg_wmp_pumpbody-disk.ipt	Production	Stahl C45	40
4.3		1	Gummi-Diaphragma	oseg_wmp_rubber-diafphragm.ipt	Production	Gummi	41
4.4		2	Flanschring	oseg_wmp_flange-ring.ipt	Production	Stahl C45	42
4.5		2	Abstandhalter	oseg_wmp_spacer.ipt	Production	Holz	43
4.6		4	verzinktes Rohr 1" x 50	oseg_wmp_galvanised-pipe-1x50.ipt	Standard	verzinktes Rohr 1"	
4.7		2	verzinkter Krümmer 1"-90°	oseg_wmp_galvanised-elbow-1-90.ipt	Standard	verzinktes Rohr 1" Fitting	
4.8		1	Einlassventil	oseg_wmp_inlet-valve.ipt	Standard	verzinktes Rückschlagventil 1" Fitting	
4.9		1	Auslassventil	oseg_wmp_outlet-valve.ipt	Standard	Verzinkte Rückschlagklappe 1" Fitting	
4.10		1	Montageschiene - U1 "x2 "x6x 350	oseg_wmp_mounting-bar.ipt	Production	Baustahlprofil	44
4.11		8	Bolzen M6x30	oseg_wmp_bolts-M6x30.ipt	Standard	sechseckige schraube, stahl verzinkt	
4.12		8	Mutter M6	oseg_wmp_nut-M6.ipt	Standard	verzinkter Stahl	



<b>PROJEKT</b> Windmuehlen-Pumpe		ERSTELLT VON D. Mosquera		GENEHMIGT VON D. Jaeger	
<b>TEIL-NAME</b> Wind Mill Pump Part list		TEIL-CODE B1		DOKUMENTTYP Part list	
UMGESTALTET VON  OPEN SOURCE ECOLOGY GERMANY		UNTERSTÜTZT VON  STIFTUNG		LIZENZ CC BY-SA 4.0	
		DATEI-NAME Wind mill pump parts list 1.1.xls		VERSION 1.0	
		SCALE		MENGE	
				SEITE 6	
				DATE 28.02.21	

2



1

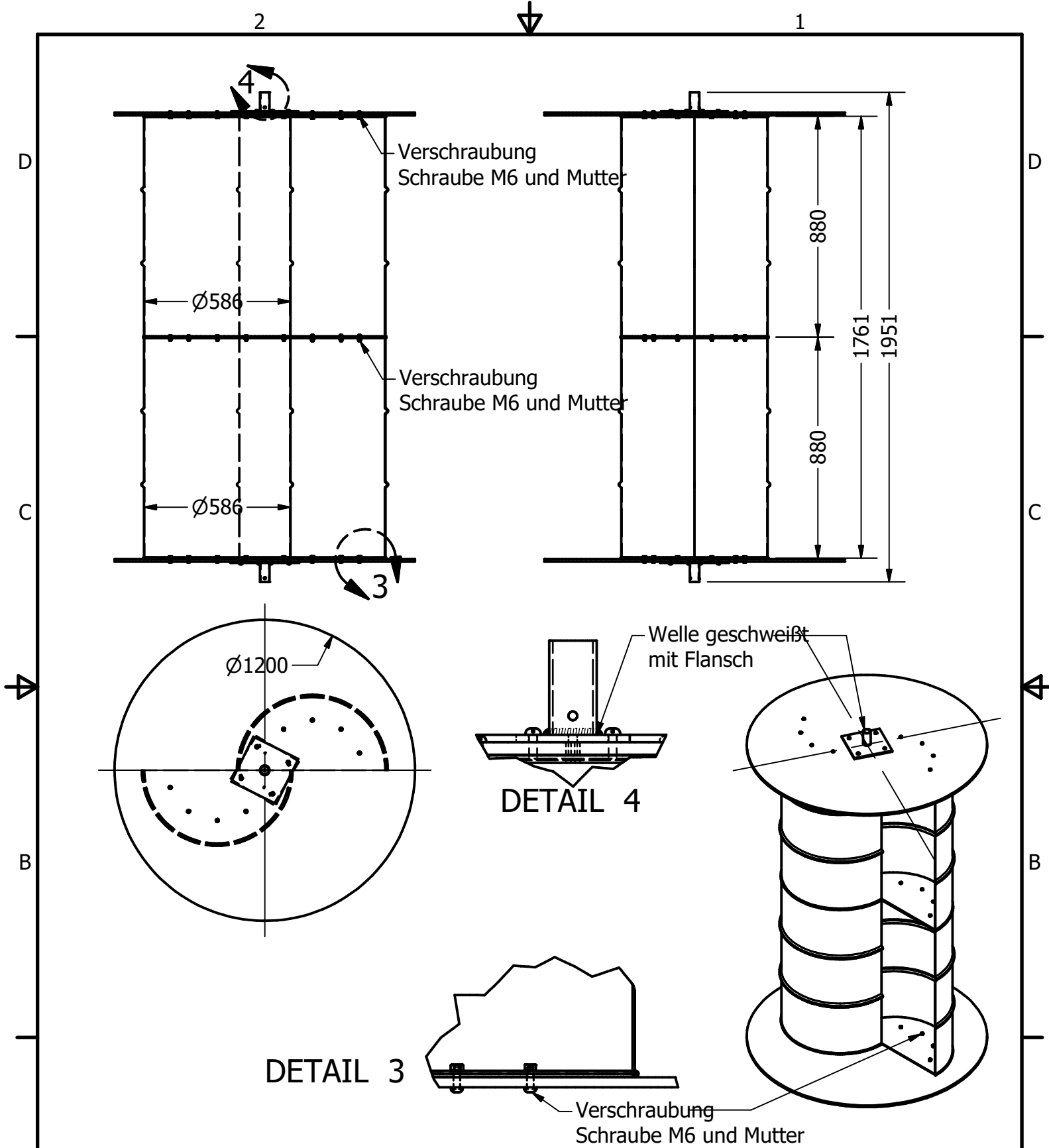



<b>PROJEKT</b> Windmuehlen-Pumpe		<b>ERSTELLT VON</b> D. Mosquera		<b>GENEHMIGT VON</b> D. Jaeger	
<b>TEIL-NAME</b> Der Rotor		<b>TEIL-CODE</b> 1		<b>DOKUMENTTYP</b> Assembly	
<b>UMGESTALTET VON</b>		<b>LIZENZ</b> CC BY-SA 4.0		<b>VERSION</b> 1.0	
<b>UNTERSTÜTZT VON</b> E.ON STIFTUNG				<b>MENGE</b>	
				<b>DATEI-NAME</b> oseg_wmp_rotor.iam	
				<b>SCALE</b> 1 / 20	
				<b>SEITE</b> 7	
				<b>DATE</b> 28.02.21	

2

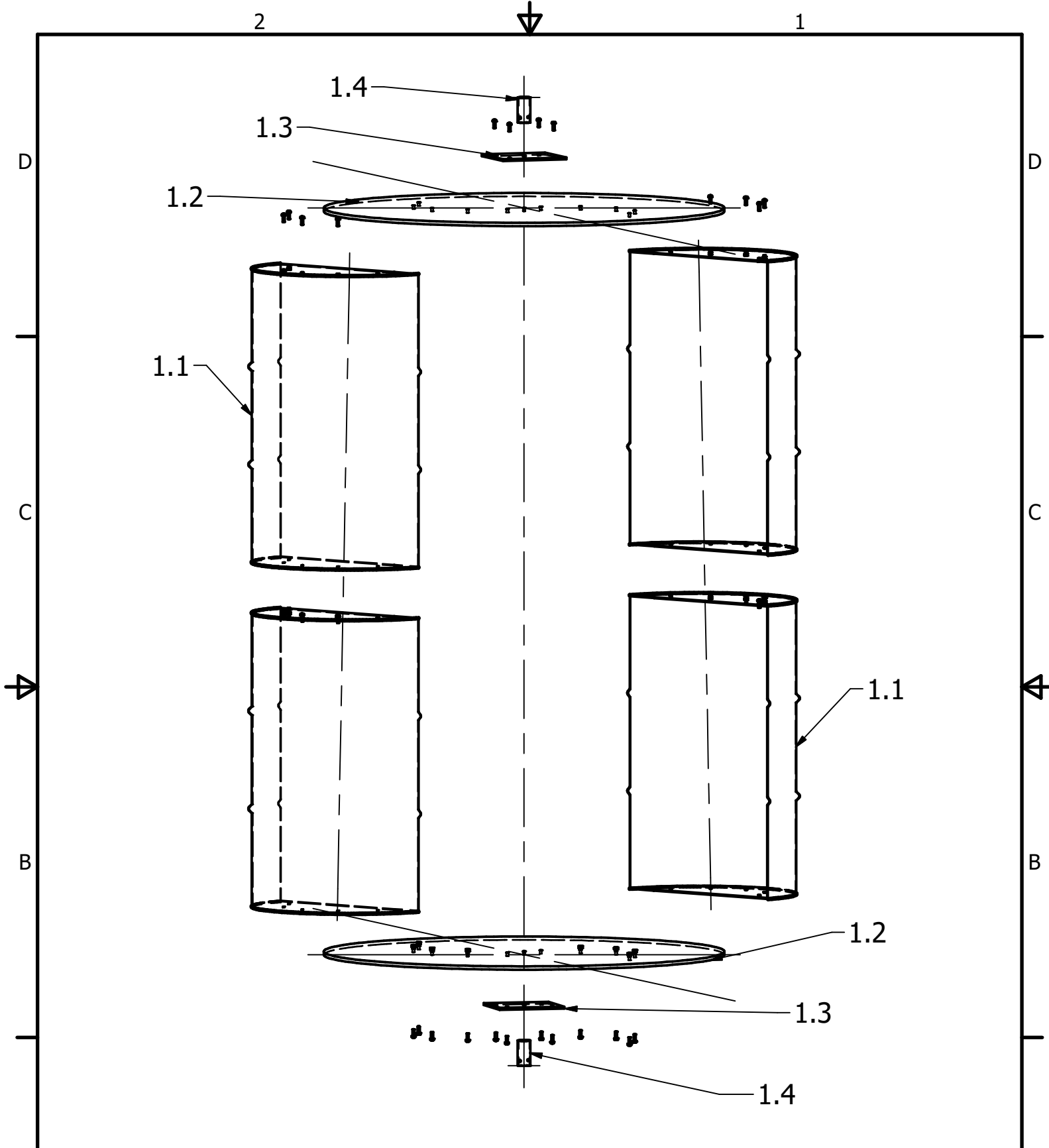

1



<b>PROJEKT</b> Windmuehlen-Pumpe		<b>ERSTELLT VON</b> D. Mosquera		<b>GENEHMIGT VON</b> D. Jaeger	
<b>TEIL-NAME</b> Der Rotor		<b>TEIL-CODE</b> 1		<b>DOKUMENTTYP</b> Assembly	
<b>UMGESTALTET VON</b>		<b>UNTERSTÜTZT VON</b>		<b>VERSION</b>	
 <small>OPEN SOURCE ECOLOGY GERMANY</small>		 <b>E.ON STIFTUNG</b>		1.0	
		<b>LIZENZ</b> CC BY-SA 4.0		<b>DATEI-NAME</b> oseg_wmp_rotor.iam	
				<b>SCALE</b> 1 / 15	
				<b>SEITE</b> 8	
				<b>MENGE</b> DATE 28.02.21	



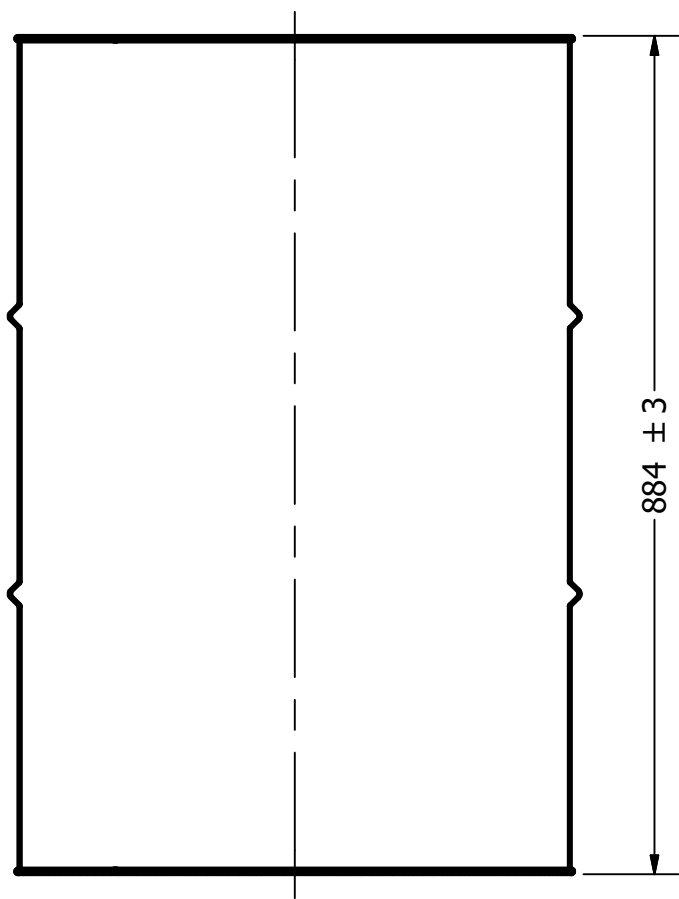

2

1

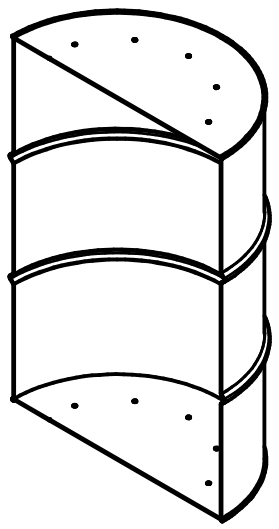
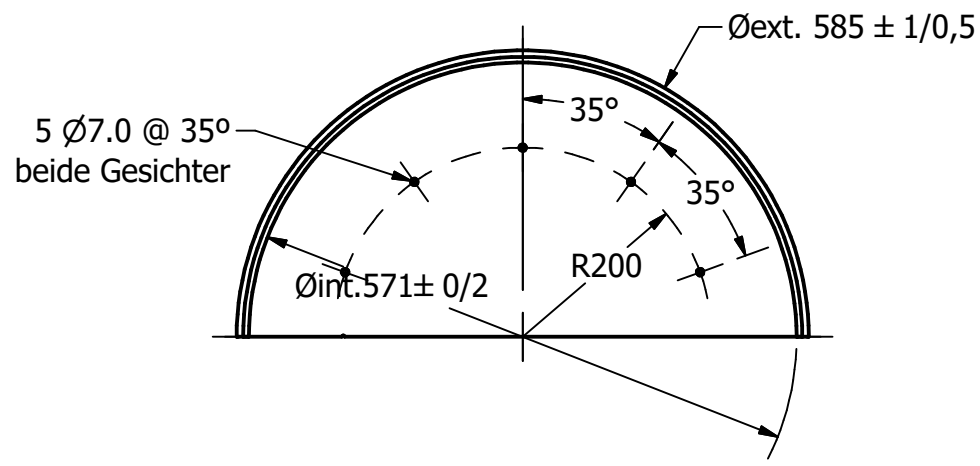

884 ± 3





<b>PROJEKT</b> Windmuehlen-Pumpe		<b>ERSTELLT VON</b> D. Mosquera		<b>GENEHMIGT VON</b> D. Jaeger	
<b>TEIL-NAME</b> 1/2 Ölfass		<b>TEIL-CODE</b> 1.1		<b>DOKUMENTTYP</b> part	
<b>UMGESTALTET VON</b> 		<b>UNTERSTÜTZT VON</b>  <b>STIFTUNG</b>		<b>LIZENZ</b> CC BY-SA 4.0	
				<b>DATEI-NAME</b> oseg_wmp_1-2-oil-drum.ipt	
				<b>SCALE</b> 1 / 8	
				<b>VERSION</b> 1.0	
				<b>MENGE</b> 1	
				<b>SEITE</b> 9	
				<b>DATE</b> 28.02.21	

2

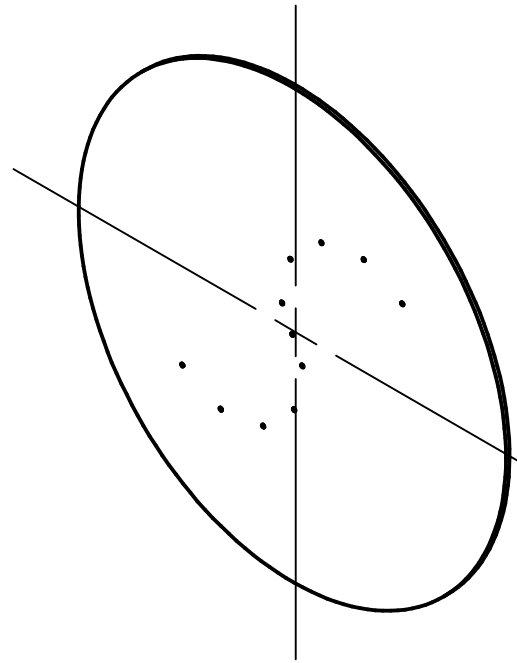
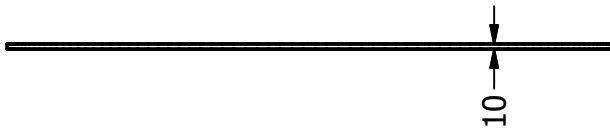
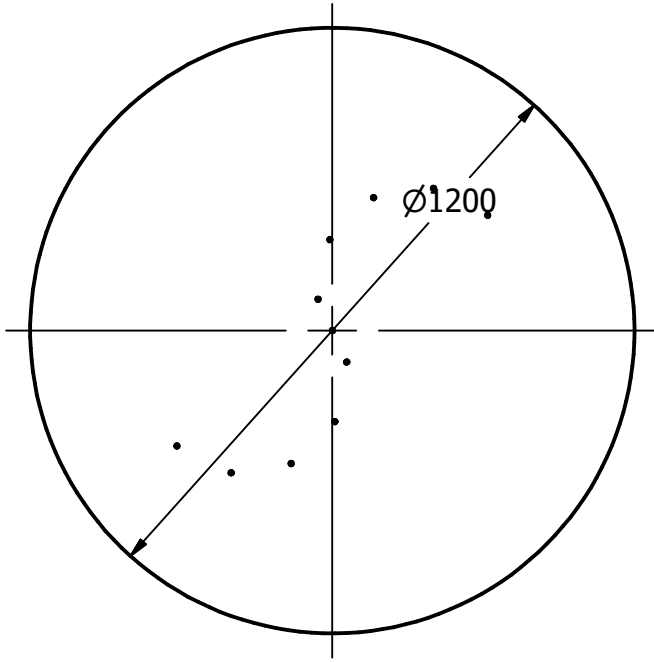

1



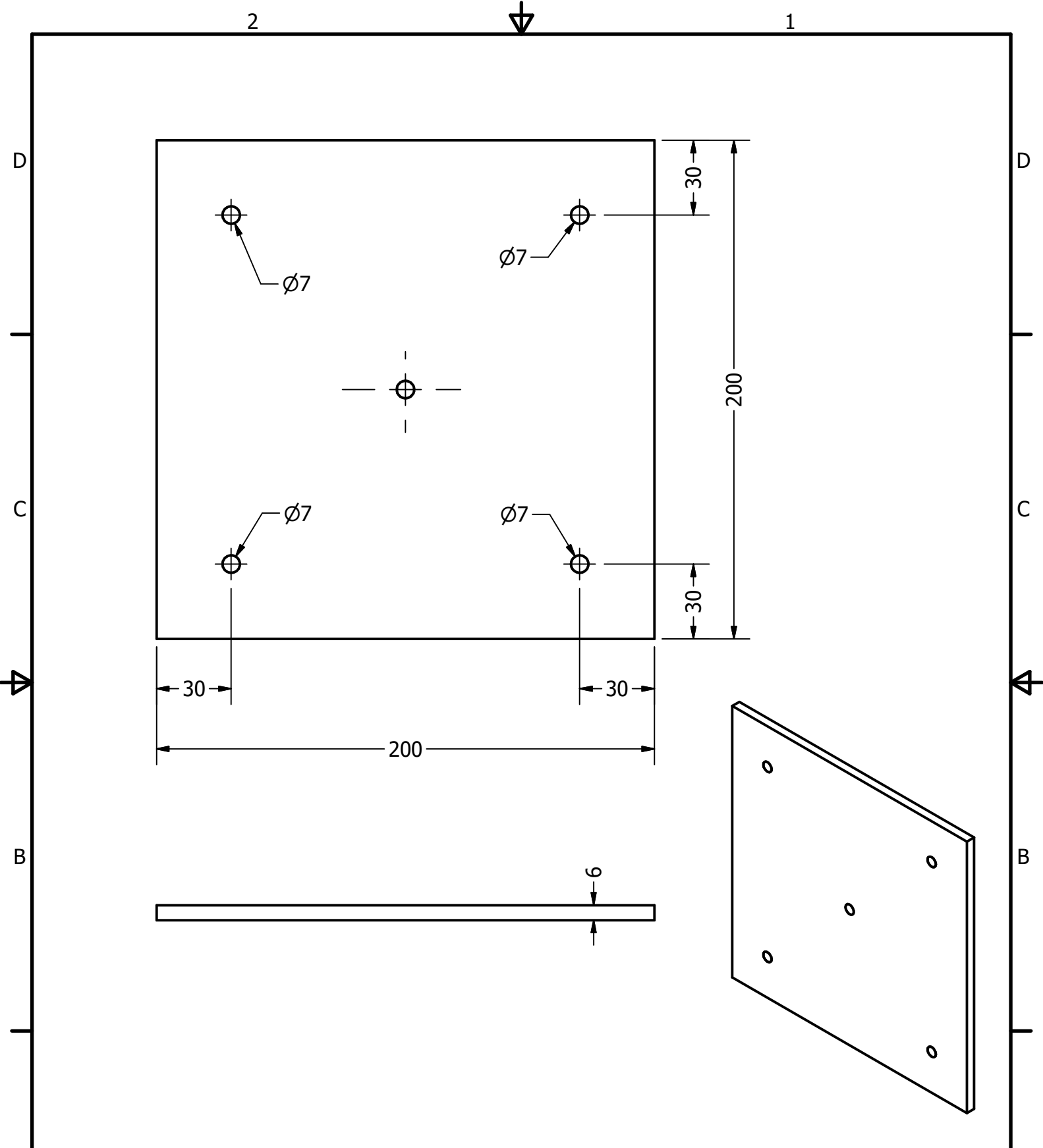

<b>PROJEKT</b> Windmuehlen-Pumpe		<b>ERSTELLT VON</b> D. Mosquera		<b>GENEHMIGT VON</b> D. Jaeger	
<b>TEIL-NAME</b> Platten aus Sperrholz		<b>TEIL-CODE</b> 1.2		<b>DOKUMENTTYP</b> part	
<b>UMGESTALTET VON</b>  OPEN SOURCE ECOLOGY GERMANY		<b>UNTERSTÜTZT VON</b>  <b>STIFTUNG</b>		<b>LIZENZ</b> CC BY-SA 4.0	
				<b>DATEI-NAME</b> oseg_wmp_plates-plywood.ipt	
				<b>SCALE</b> 1 / 15	
				<b>WERKSTOFF</b> Sperrholz	
				<b>VERSION</b> 1.0	
				<b>MENGE</b> 10	
				<b>DATE</b> 28.02.21	



<b>PROJEKT</b> Windmuehlen-Pumpe		<b>ERSTELLT VON</b> D. Mosquera		<b>GENEHMIGT VON</b> D. Jaeger	
<b>TEIL-NAME</b> Flanschstütze		<b>TEIL-CODE</b> 1.3		<b>DOKUMENTTYP</b> part	
<b>UMGESTALTET VON</b>		<b>UNTERSTÜTZT VON</b>		<b>WERKSTOFF</b> STahl C45	
 <small>OPEN SOURCE ECOLOGY GERMANY</small>		 <b>E.ON</b> <b>STIFTUNG</b>		<b>LIZENZ</b> CC BY-SA 4.0	
				<b>DATEI-NAME</b> oseg_wmp_flange-support.ipt	
				<b>MENGE</b>	
				<b>SCALE</b> 1 / 2	
				<b>SEITE</b> 11	
				<b>DATE</b> 28.02.21	

2

1

D

D

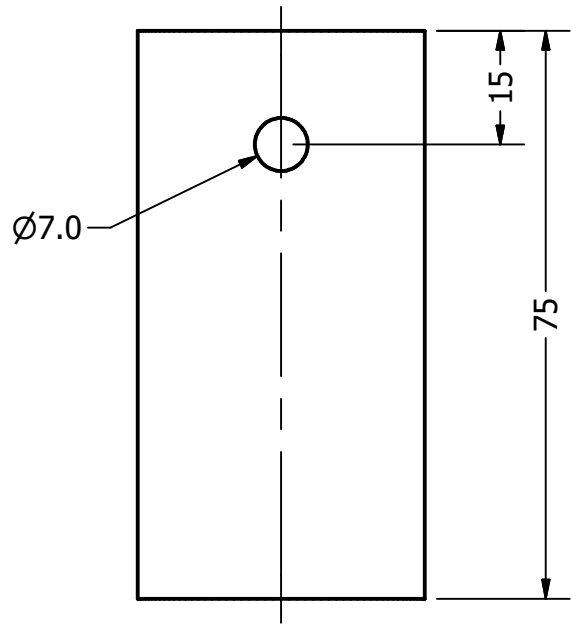

C

C

B

B

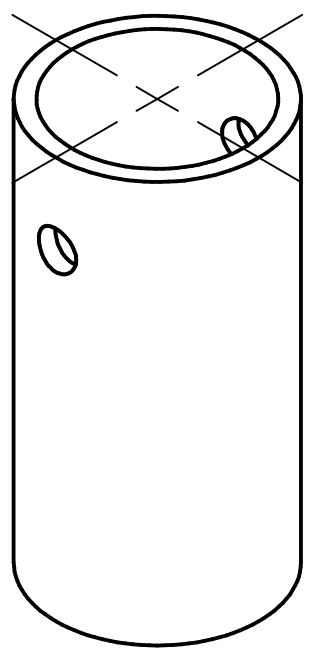
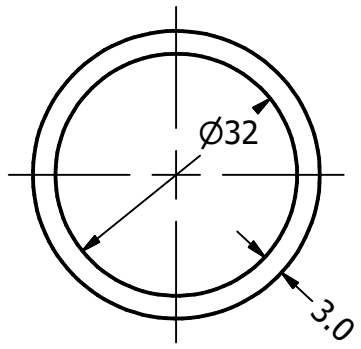



B

B

A

A



<b>PROJEKT</b> Windmuehlen-Pumpe		<b>ERSTELLT VON</b> D. Mosquera		<b>GENEHMIGT VON</b> D. Jaeger	
<b>TEIL-NAME</b> Rotorwelle		<b>TEIL-CODE</b> 1.4		<b>DOKUMENTTYP</b> part	
<b>UMGESTALTET VON</b> 		<b>UNTERSTÜTZT VON</b>  <b>STIFTUNG</b>		<b>WERKSTOFF</b> Stahl C45	
<b>LIZENZ</b> CC BY-SA 4.0		<b>DATEI-NAME</b> oseg_wmp_rotor-shaft.ipt		<b>VERSION</b> 1.0	
		<b>SCALE</b> 1 : 1		<b>MENGE</b> 12	
				<b>DATE</b> 28.02.21	

2

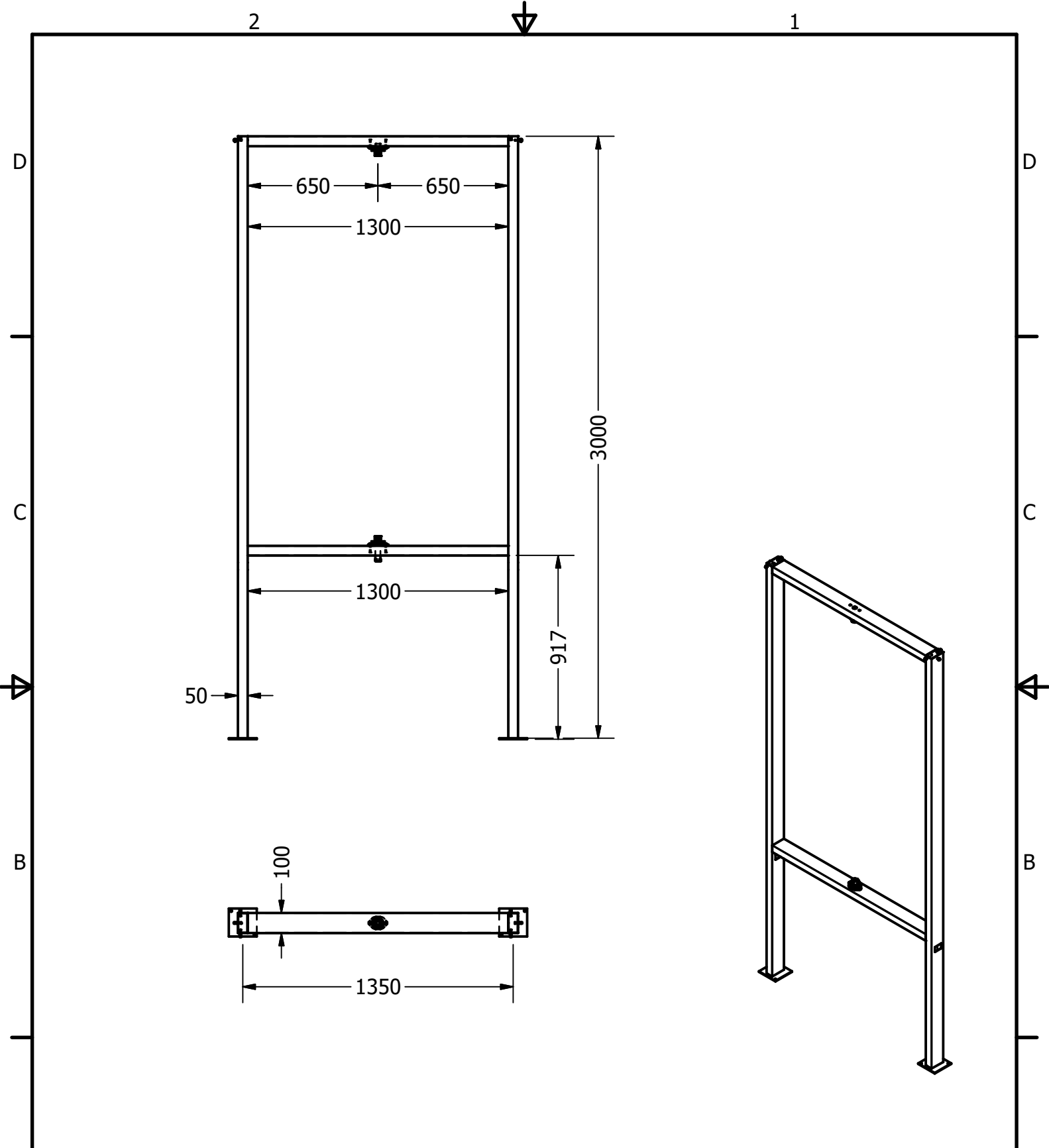

1



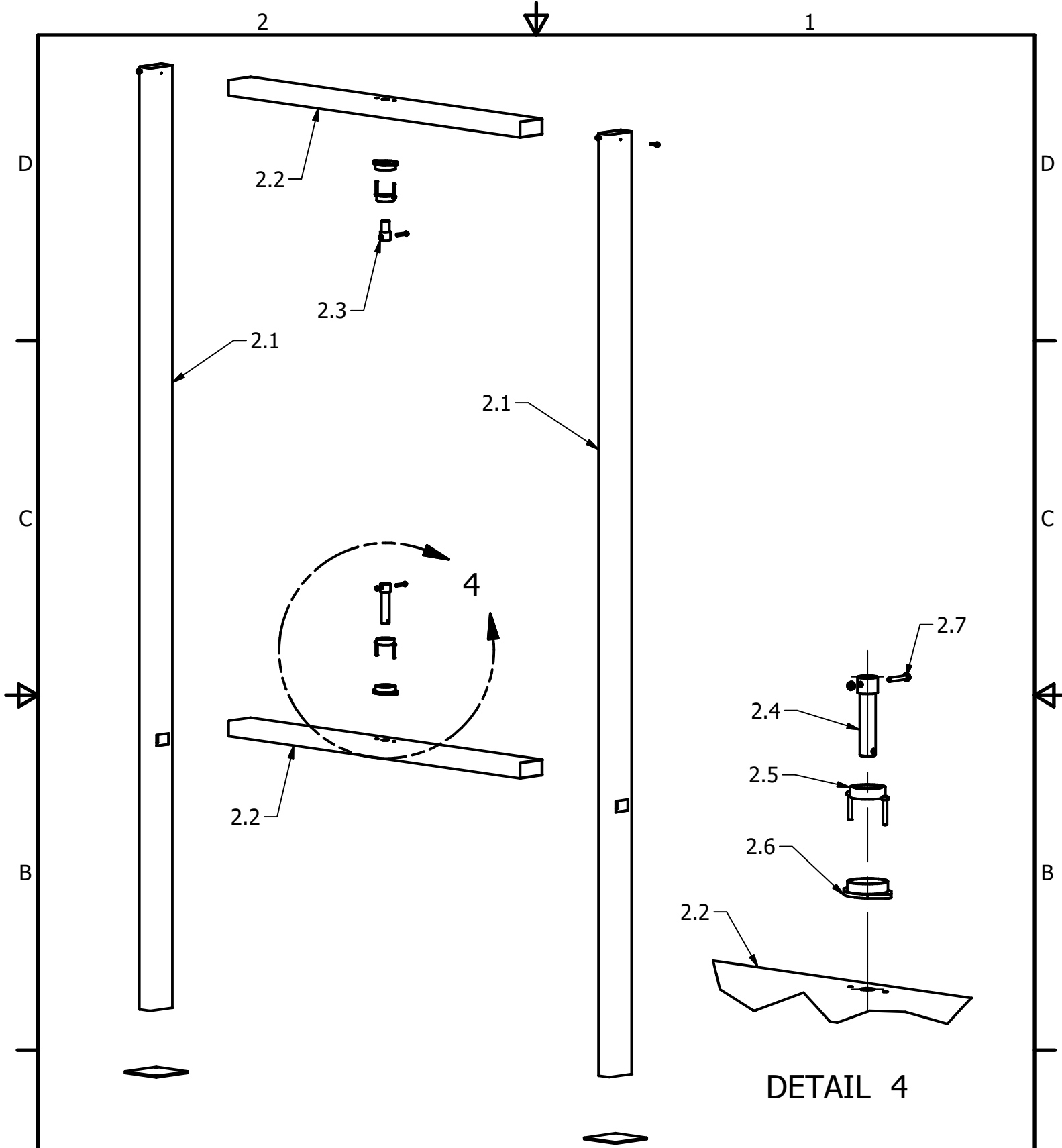

<b>PROJEKT</b> Windmuehlen-Pumpe		<b>ERSTELLT VON</b> D. Mosquera		<b>GENEHMIGT VON</b> D. Jaeger	
<b>TEIL-NAME</b> Rahmen		<b>TEIL-CODE</b> 2		<b>DOKUMENTTYP</b> Assembly	
<b>UMGESTALTET VON</b> 		<b>UNTERSTÜTZT VON</b>  <b>STIFTUNG</b>		<b>WERKSTOFF</b> ASTM-A36	
<b>LIZENZ</b> CC BY-SA 4.0		<b>DATEI-NAME</b> oseg_wmp_frame.iam		<b>VERSION</b> 1.0	
		<b>SCALE</b> 1 / 25		<b>MENGE</b> 13	
				<b>DATE</b> 28.02.21	



<b>PROJEKT</b> Windmuehlen-Pumpe		<b>ERSTELT VON</b> D. Mosquera		<b>GENEHMIGT VON</b> D. Jaeger	
<b>TEIL-NAME</b> Rahmen		<b>TEIL-CODE</b> 2		<b>DOKUMENTTYP</b> Assembly	
<b>UMGESTALTET VON</b> 		<b>UNTERSTÜTZT VON</b>  <b>STIFTUNG</b>		<b>LIZENZ</b> CC BY-SA 4.0	
				<b>DATEI-NAME</b> oseg_wmp_frame.iam	
				<b>SCALE</b> 1 / 16	
				<b>VERSION</b> 1.0	
				<b>MENGE</b> 14	
				<b>DATE</b> 28.02.21	

2



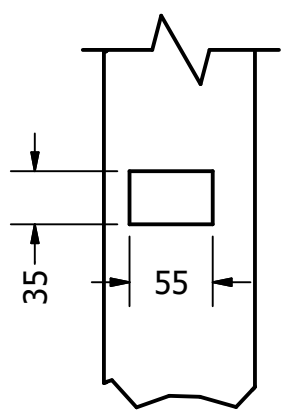

1

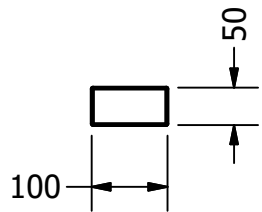
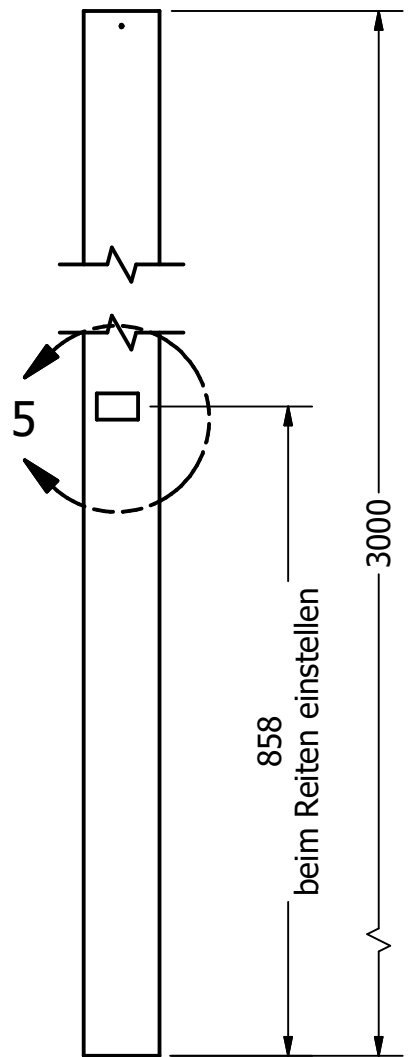

DETAIL 5



<b>PROJEKT</b> Windmuehlen-Pumpe		<b>ERSTELLT VON</b> D. Mosquera		<b>GENEHMIGT VON</b> D. Jaeger	
<b>TEIL-NAME</b> Stützlatten 50x25x3000		<b>TEIL-CODE</b> 2.1		<b>DOKUMENTTYP</b> part	
<b>UMGESTALTET VON</b> 		<b>UNTERSTÜTZT VON</b>  <b>STIFTUNG</b>		<b>WERKSTOFF</b> ASTM-A36	
<b>LIZENZ</b> CC BY-SA 4.0		<b>DATEI-NAME</b> wmp_supporting-laths-100x50x3000.ipt		<b>VERSION</b> 1.0	
		<b>SCALE</b> 1 / 10		<b>MENGE</b> 15	
				<b>DATE</b> 28.02.21	

2

1

D

D

C

C

B

B

A

A

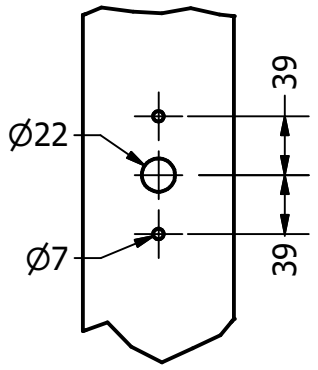
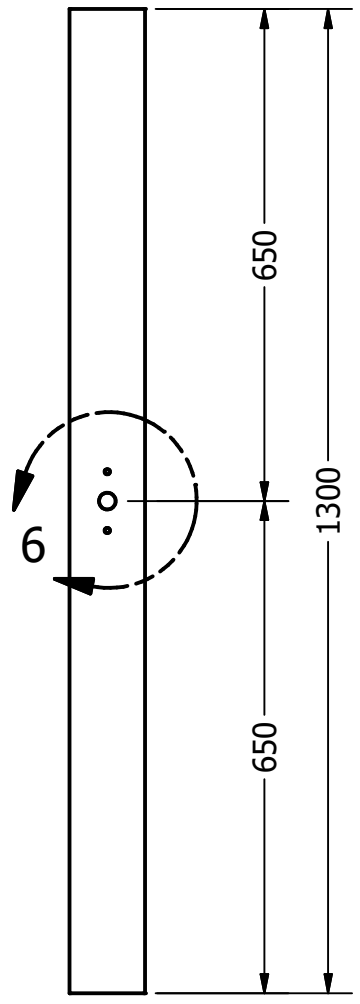

DETAIL 6

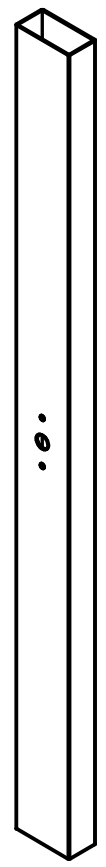

<b>PROJEKT</b> Windmuehlen-Pumpe		<b>ERSTELLT VON</b> D. Mosquera		<b>GENEHMIGT VON</b> D. Jaeger	
<b>TEIL-NAME</b> Stützlatten 50x25x1300		<b>TEIL-CODE</b> 2.2		<b>DOKUMENTTYP</b> part	
<b>UMGESTALTET VON</b> 		<b>UNTERSTÜTZT VON</b> 		<b>WERKSTOFF</b> ASTM-A36	
<b>LIZENZ</b> CC BY-SA 4.0		<b>DATEI-NAME</b> wmp_supporting-laths-100x50x1300.ipt		<b>VERSION</b> 1.0	
		<b>SCALE</b> 1 / 10		<b>MENGE</b> 16	
				<b>DATE</b> 28.02.21	

2

1





2

1

D

D

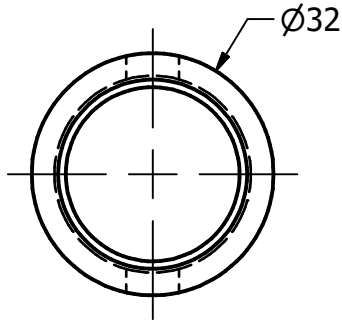

C

C

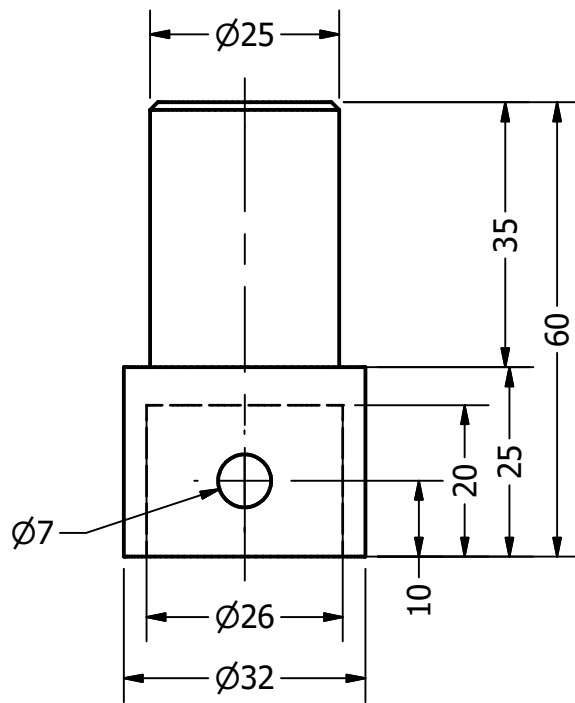

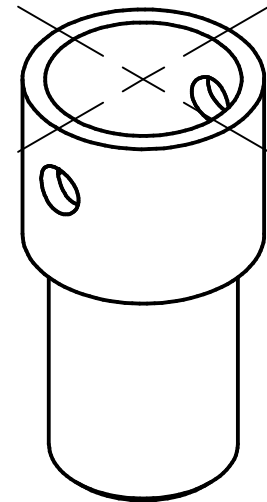

B

B



A

A

<b>PROJEKT</b> Windmuehlen-Pumpe		<b>ERSTELLT VON</b> D. Mosquera		<b>GENEHMIGT VON</b> D. Jaeger	
<b>TEIL-NAME</b> oberer Adapter		<b>TEIL-CODE</b> 2.3		<b>DOKUMENTTYP</b> part	
<b>UMGESTALTET VON</b>  OPEN SOURCE ECOLOGY GERMANY		<b>UNTERSTÜTZT VON</b>  <b>E.ON</b> <b>STIFTUNG</b>		<b>LIZENZ</b> CC BY-SA 4.0	
				<b>DATEI-NAME</b> oseg_wmp_top-adaptor.ipt	
				<b>VERSION</b> 1.0	
				<b>MENGE</b> 1	
				<b>SCALE</b> 1 : 1	
				<b>SEITE</b> 17	
				<b>DATE</b> 28.02.21	

2

1



2

1

D

D

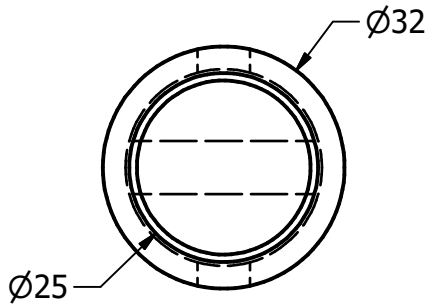

C

C

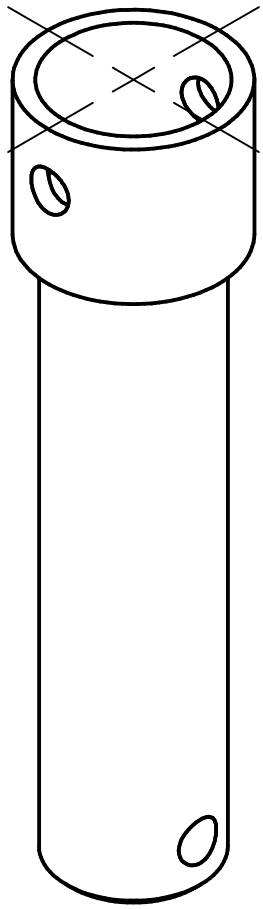
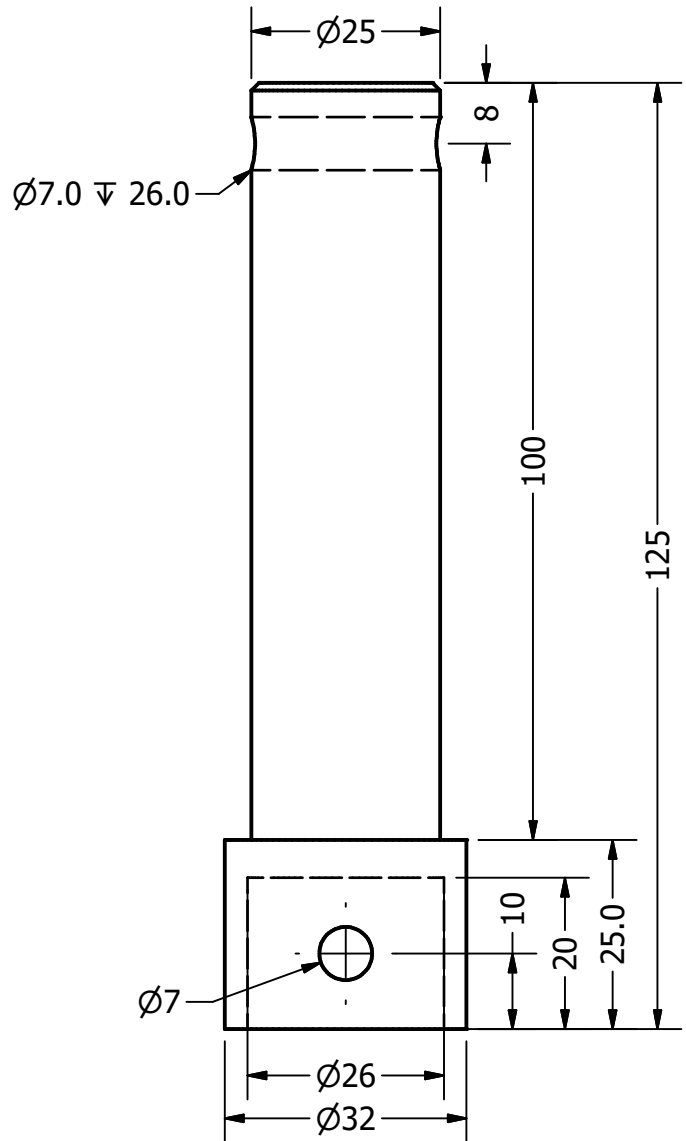



B

B

A

A

<b>PROJEKT</b> Windmuehlen-Pumpe		<b>ERSTELLT VON</b> D. Mosquera		<b>GENEHMIGT VON</b> D. Jaeger	
<b>TEIL-NAME</b> unterer Adapter		<b>TEIL-CODE</b> 2.4		<b>DOKUMENTTYP</b> Part	
<b>UMGESTALTET VON</b> 		<b>UNTERSTÜTZT VON</b>  <b>STIFTUNG</b>		<b>WERKSTOFF</b> Stahl C45	
<b>LIZENZ</b> CC BY-SA 4.0		<b>DATEI-NAME</b> oseg_wmp_bottom-adaptor.ipt		<b>VERSION</b> 1.0	
		<b>SCALE</b> 1 : 1		<b>MENGE</b> 18	
				<b>DATE</b> 28.02.21	

2



1

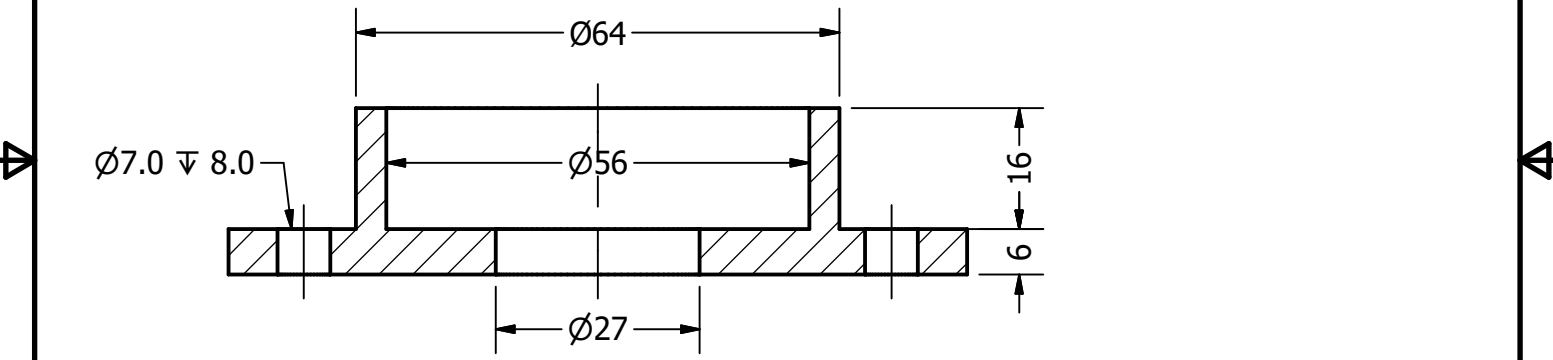
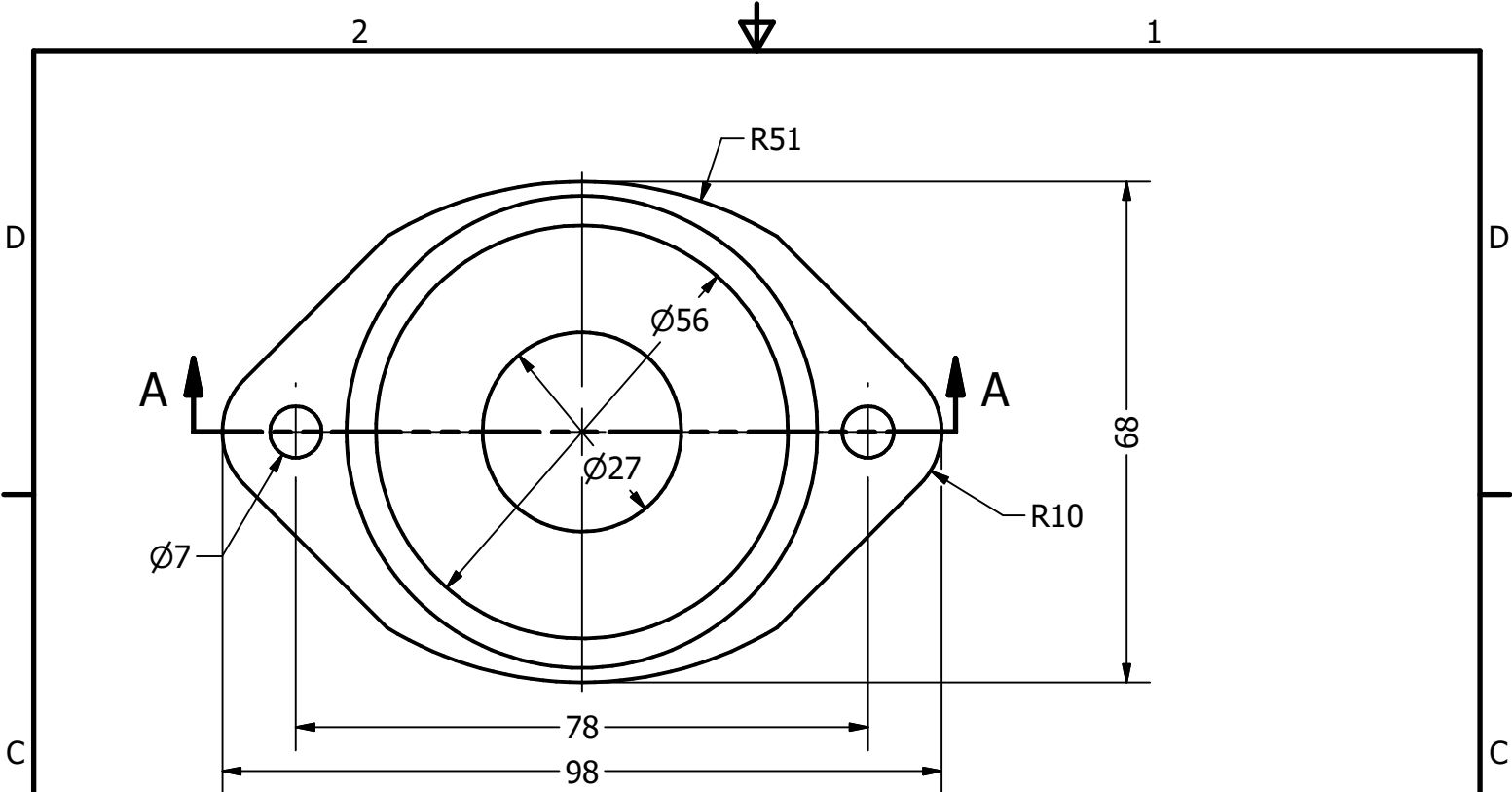



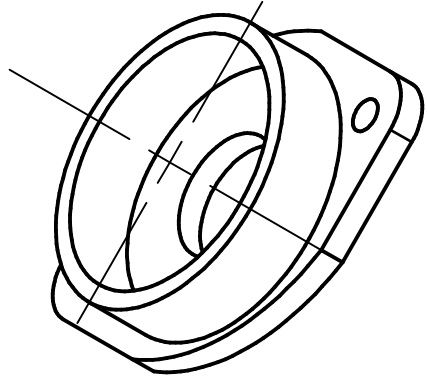

SECTION A-A

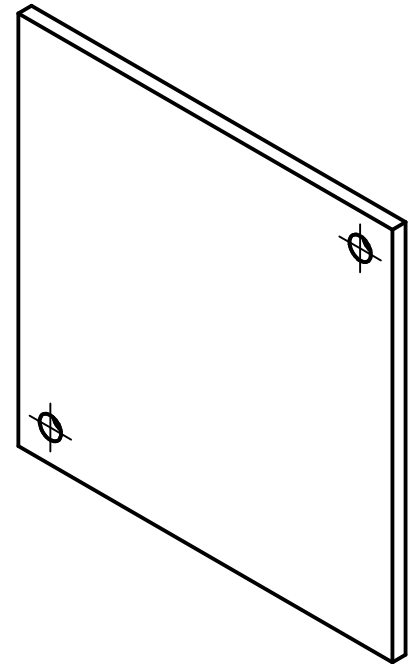
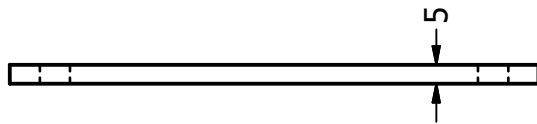
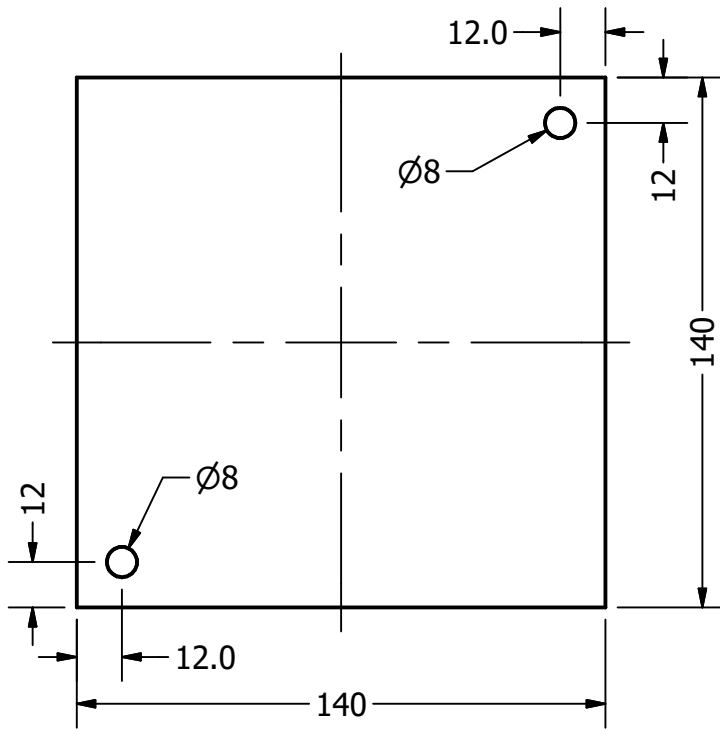

<b>PROJEKT</b> Windmuehlen-Pumpe		<b>ERSTELT VON</b> D. Mosquera		<b>GENEHMIGT VON</b> D. Jaeger	
<b>TEIL-NAME</b> Lagerhalterung		<b>TEIL-CODE</b> 2.6		<b>DOKUMENTTYP</b> part	
<b>UMGESTALTET VON</b> 		<b>UNTERSTÜTZT VON</b> 		<b>WERKSTOFF</b> Stahl C45	
		<b>LIZENZ</b> CC BY-SA 4.0		<b>DATEI-NAME</b> oseg_wmp_bearing-support.ipt	
				<b>VERSION</b> 1.0	
				<b>MENGE</b> 	
				<b>SCALE</b> 1 : 1	
				<b>SEITE</b> 19	
				<b>DATE</b> 28.02.21	





<b>PROJEKT</b> Windmuehlen-Pumpe		<b>ERSTELLT VON</b> D. Mosquera		<b>GENEHMIGT VON</b> D. Jaeger	
<b>TEIL-NAME</b> Rechteckige Flansche		<b>TEIL-CODE</b> 2.7		<b>DOKUMENTTYP</b> part	
<b>UMGESTALTET VON</b>  OPEN SOURCE ECOLOGY GERMANY		<b>UNTERSTÜTZT VON</b>  <b>STIFTUNG</b>		<b>LIZENZ</b> CC BY-SA 4.0	
		<b>DATEI-NAME</b> oseg_wmp_rectangular-flancher.ipt		<b>VERSION</b> 1.0	
		<b>SCALE</b> 1 / 2		<b>MENGE</b> DATE	
				20 28.02.21	

2

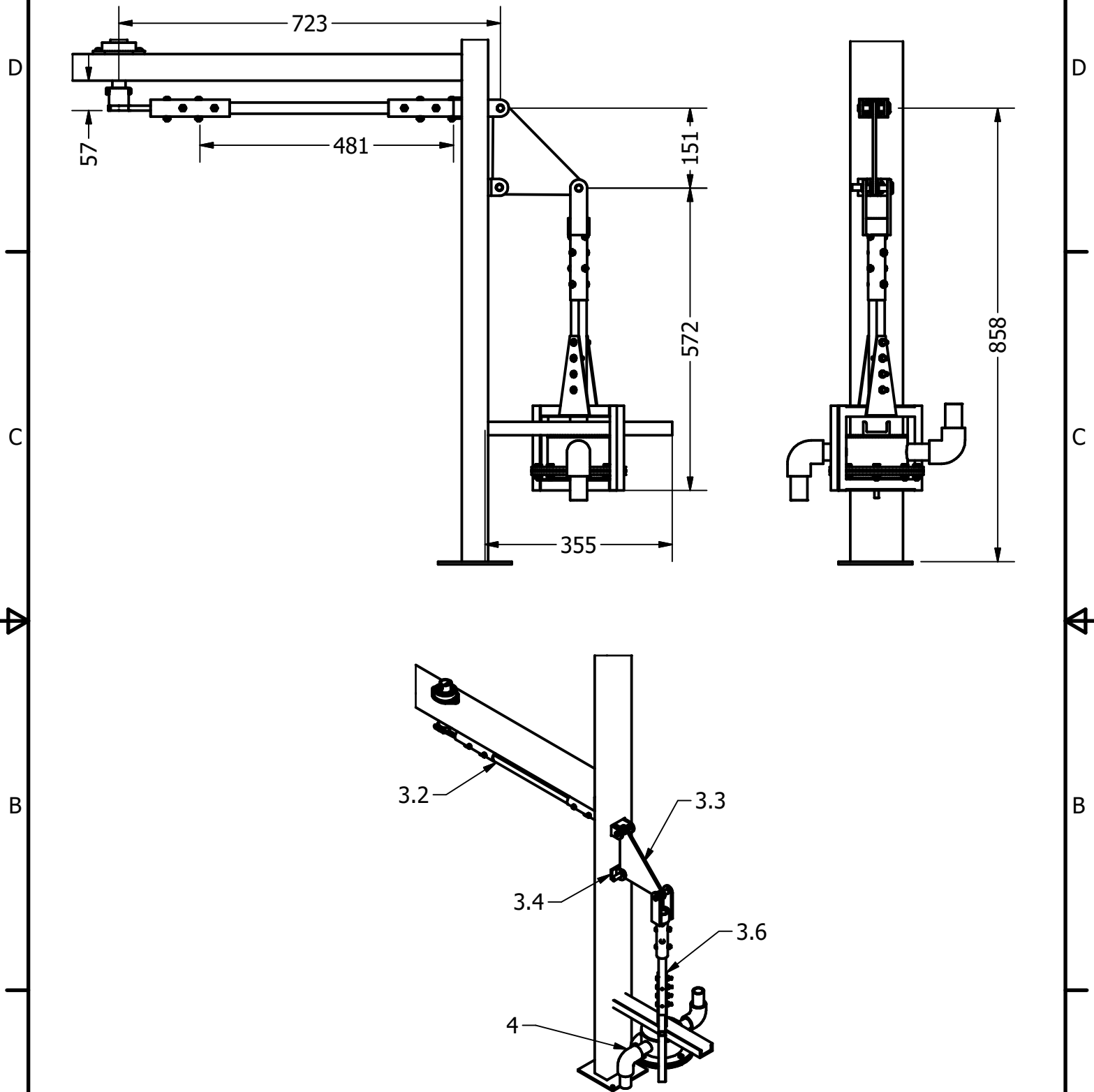
1



<b>PROJEKT</b> Windmuehlen-Pumpe		<b>ERSTELLT VON</b> D. Mosquera		<b>GENEHMIGT VON</b> D. Jaeger	
<b>TEIL-NAME</b> Antrieb		<b>TEIL-CODE</b> 3		<b>DOKUMENTTYP</b> Assembly	
<b>UMGESTALTET VON</b> 		<b>UNTERSTÜTZT VON</b>  <b>STIFTUNG</b>		<b>LIZENZ</b> CC BY-SA 4.0	
				<b>DATEI-NAME</b> oseg_wmp_drive.iam	
				<b>VERSION</b> 1.0	
				<b>MENGE</b>	
				<b>SCALE</b> 1 / 10	
				<b>SEITE</b> 21	
				<b>DATE</b> 28.02.21	



2

1

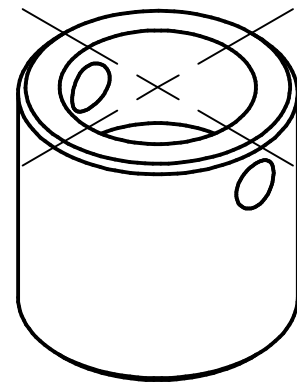
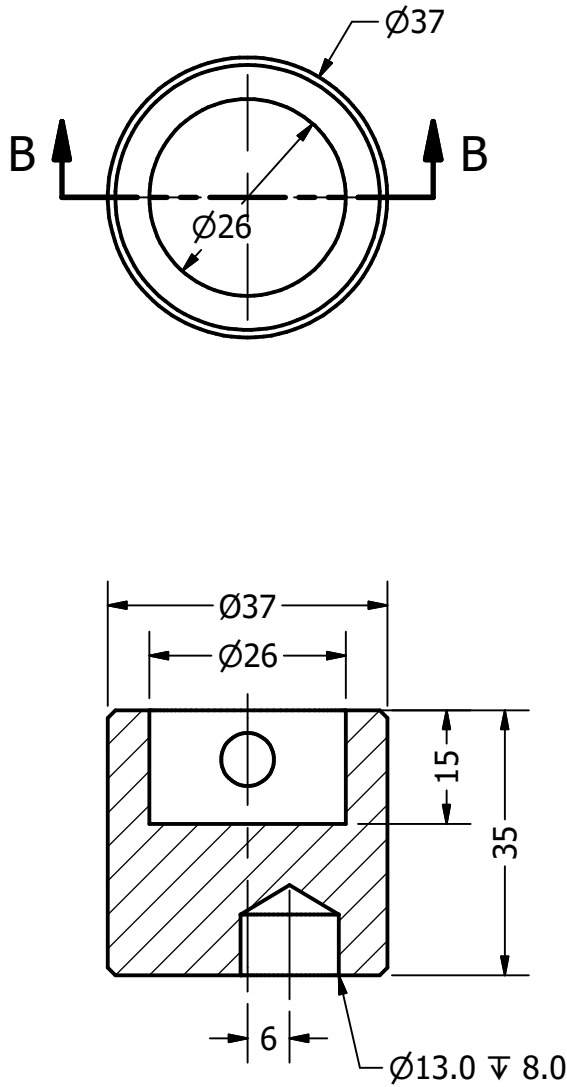



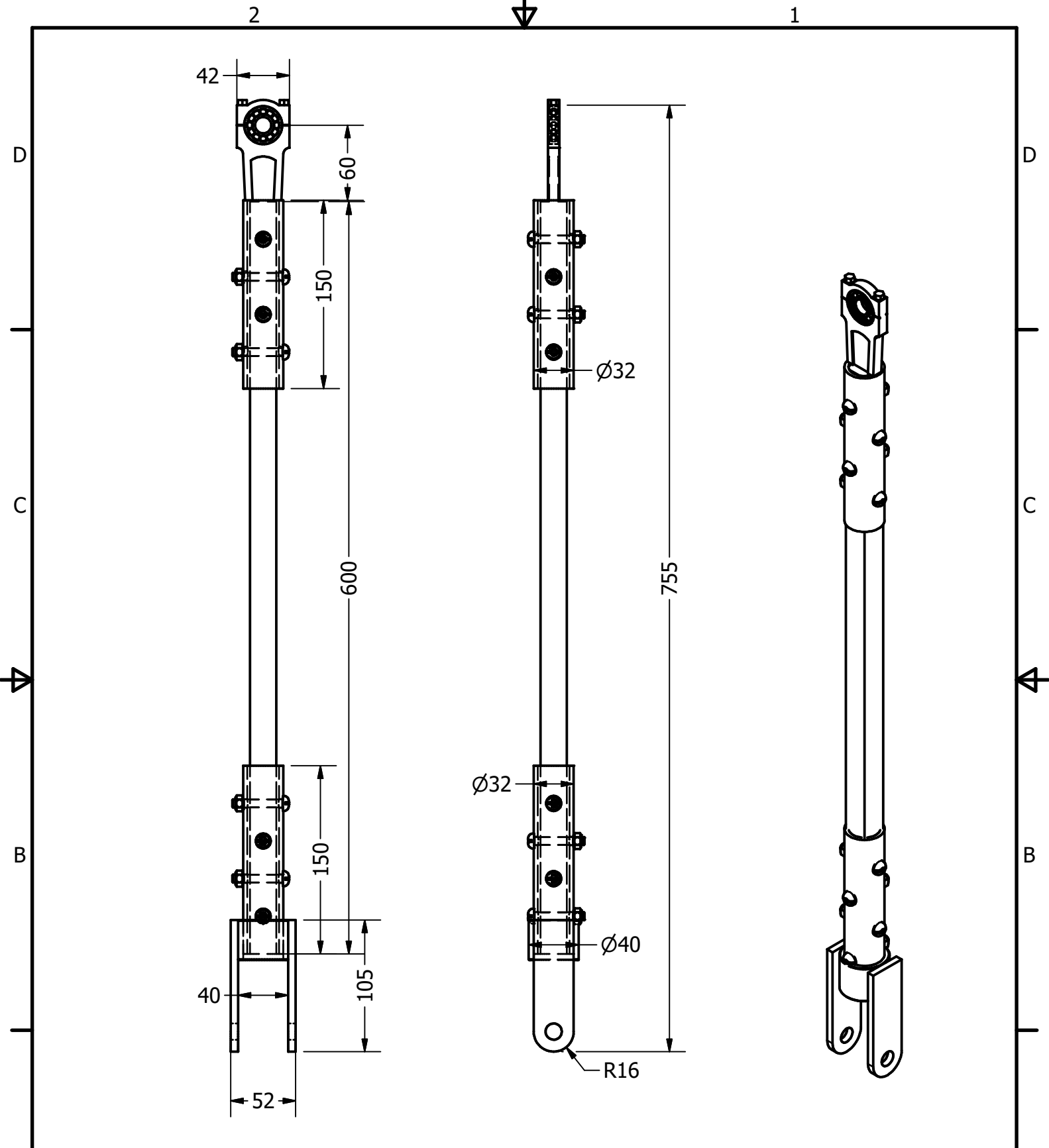

SECTION B-B

<b>PROJEKT</b> Windmuehlen-Pumpe		<b>ERSTELLT VON</b> D. Mosquera		<b>GENEHMIGT VON</b> D. Jaeger	
<b>TEIL-NAME</b> Exzentrisch		<b>TEIL-CODE</b> 3.1		<b>DOKUMENTTYP</b> part	
<b>UMGESTALTET VON</b>  OPEN SOURCE ECOLOGY GERMANY		<b>UNTERSTÜTZT VON</b>  E.ON STIFTUNG		<b>WERKSTOFF</b> Stahl C45	
<b>LIZENZ</b> CC BY-SA 4.0		<b>DATEI-NAME</b> oseg_wmp_Excentric.ipt		<b>VERSION</b> 1.0	
		<b>SCALE</b> 1 : 1		<b>MENGE</b> 1	
				<b>SEITE</b> 22	
				<b>DATE</b> 28.02.21	



<b>PROJEKT</b> Windmuehlen-Pumpe		<b>ERSTELLT VON</b> D. Mosquera		<b>GENEHMIGT VON</b> D. Jaeger	
<b>TEIL-NAME</b> horizontale Pleuelstange		<b>TEIL-CODE</b> 3.2		<b>DOKUMENTTYP</b> Assembly	
<b>UMGESTALTET VON</b>  OPEN SOURCE ECOLOGY GERMANY		<b>UNTERSTÜTZT VON</b>  E.ON STIFTUNG		<b>LIZENZ</b> CC BY-SA 4.0	
		<b>DATEI-NAME</b> wmp horizontal-connecting-rod		<b>VERSION</b> 1.0	
		<b>SCALE</b> 1 / 4		<b>MENGE</b> 1	
				<b>SEITE</b> 23	
				<b>DATE</b> 28.02.21	

2

1

D

D

C

C

B

B

A

A

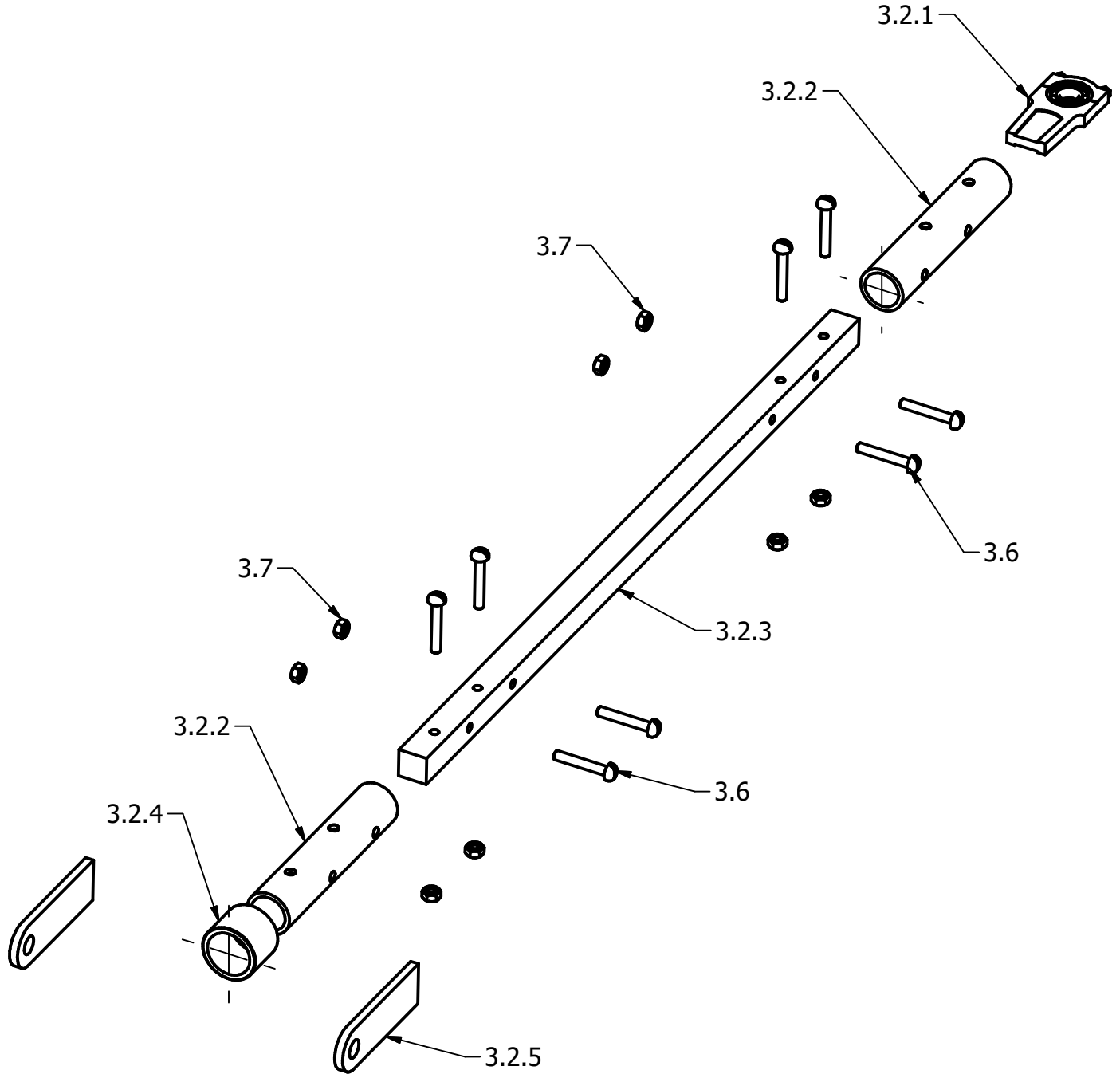



<b>PROJEKT</b> Windmuehlen-Pumpe		<b>ERSTELT VON</b> D. Mosquera		<b>GENEHMIGT VON</b> D. Jaeger	
<b>TEIL-NAME</b> horizontale Pleuelstange		<b>TEIL-CODE</b> 3.2		<b>DOKUMENTTYP</b> Assembly	
<b>UMGESTALTET VON</b>		<b>UNTERSTÜTZT VON</b> E.ON STIFTUNG		<b>LIZENZ</b> CC BY-SA 4.0	
		seg_wmp_horizontal-connecting-rod		<b>VERSION</b> iam 1.0	
				<b>MENGE</b>	
				<b>SCALE</b> 1 / 4	
				<b>SEITE</b> 24	
				<b>DATE</b> 28.02.21	

2

1

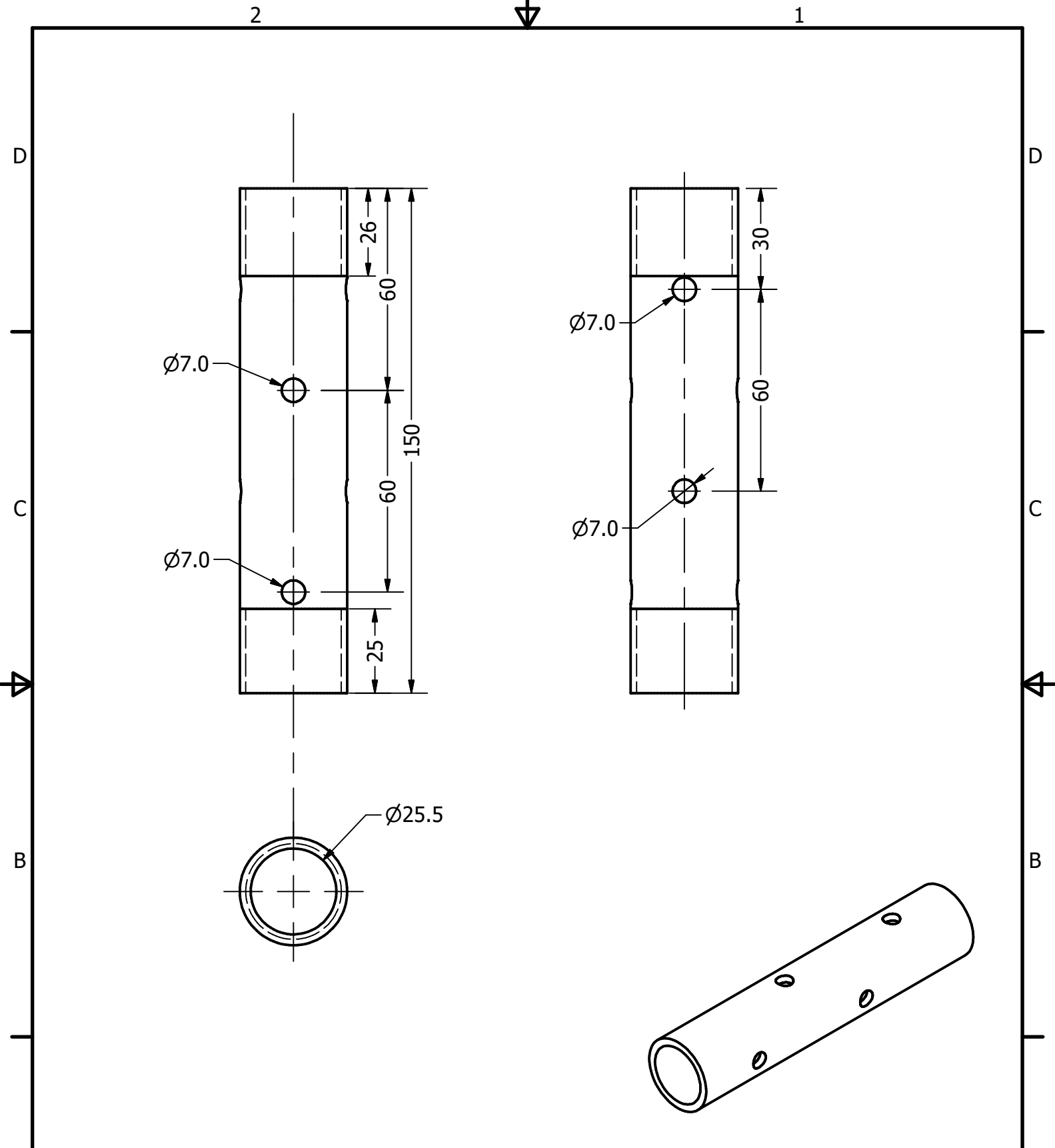



<b>PROJEKT</b> Windmuehlen-Pumpe		ERSTELT VON D. Mosquera		GENEHMIGT VON D. Jaeger	
<b>TEIL-NAME</b> Wasserrohr 1 "x150		TEIL-CODE 3.2.2		DOKUMENTTYP part	
UMGESTALTET VON  OPEN SOURCE ECOLOGY GERMANY		UNTERSTÜTZT VON  STIFTUNG		WERKSTOFF ASTM A36	
LIZENZ CC BY-SA 4.0		DATEI-NAME oseg_wmp_water-pipe-1x150.ipt		VERSION 1.0	
		SCALE 1 : 1,5		MENGE DATE	
				SEITE 25	
				DATE 28.02.21	

2

1

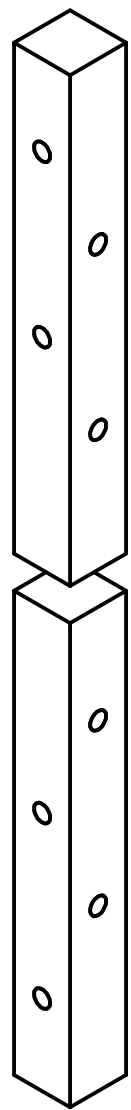
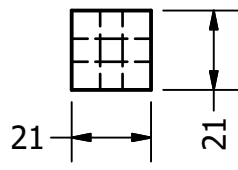
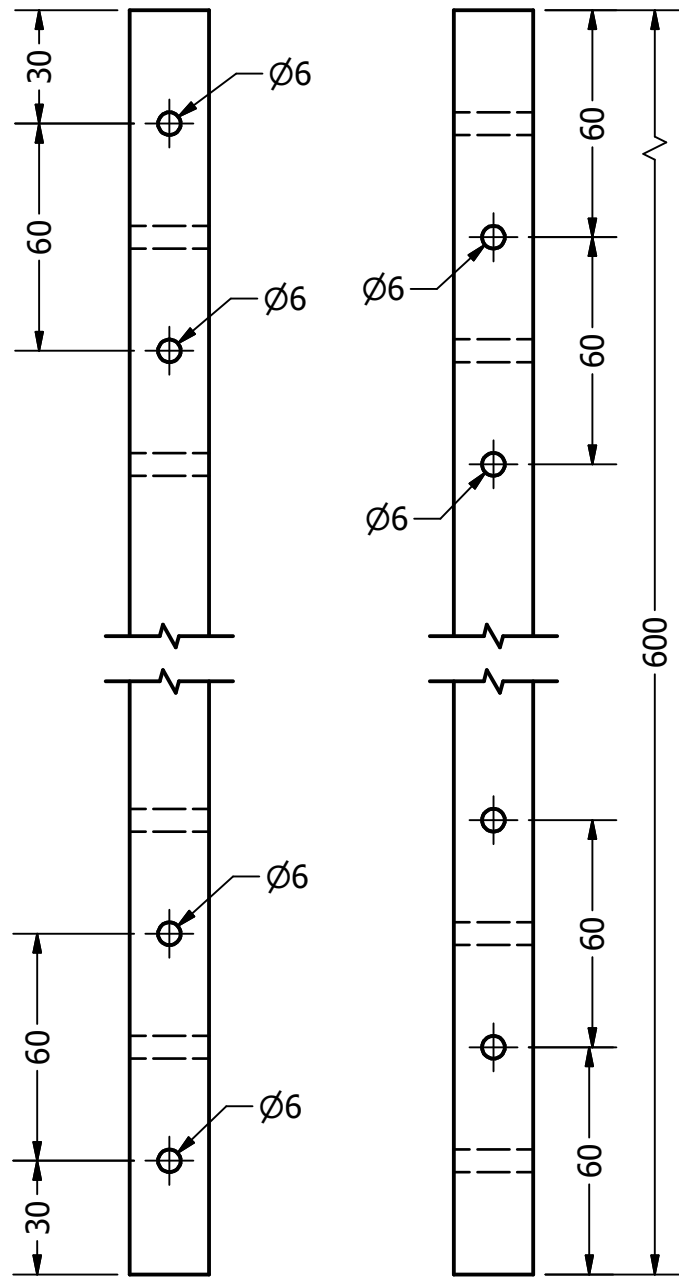

D

D

C

C

B

B

A

A



<b>PROJEKT</b> Windmuehlen-Pumpe		<b>ERSTELLT VON</b> D. Mosquera		<b>GENEHMIGT VON</b> D. Jaeger	
<b>TEIL-NAME</b> Stange horizontal 1x1x 600		<b>TEIL-CODE</b> 3.2.3		<b>DOKUMENTTYP</b> part	
<b>UMGESTALTET VON</b>		<b>UNTERSTÜTZT VON</b> E.ON STIFTUNG		<b>LIZENZ</b> CC BY-SA 4.0	
				<b>DATEI-NAME</b> oseg_wmp_rod-horizont-1x1x600.ipt	
				<b>VERSION</b> 1.0	
				<b>MENGE</b>	
				<b>SCALE</b> 1 / 2	
				<b>SEITE</b> 26	
				<b>DATE</b> 28.02.21	

2

1

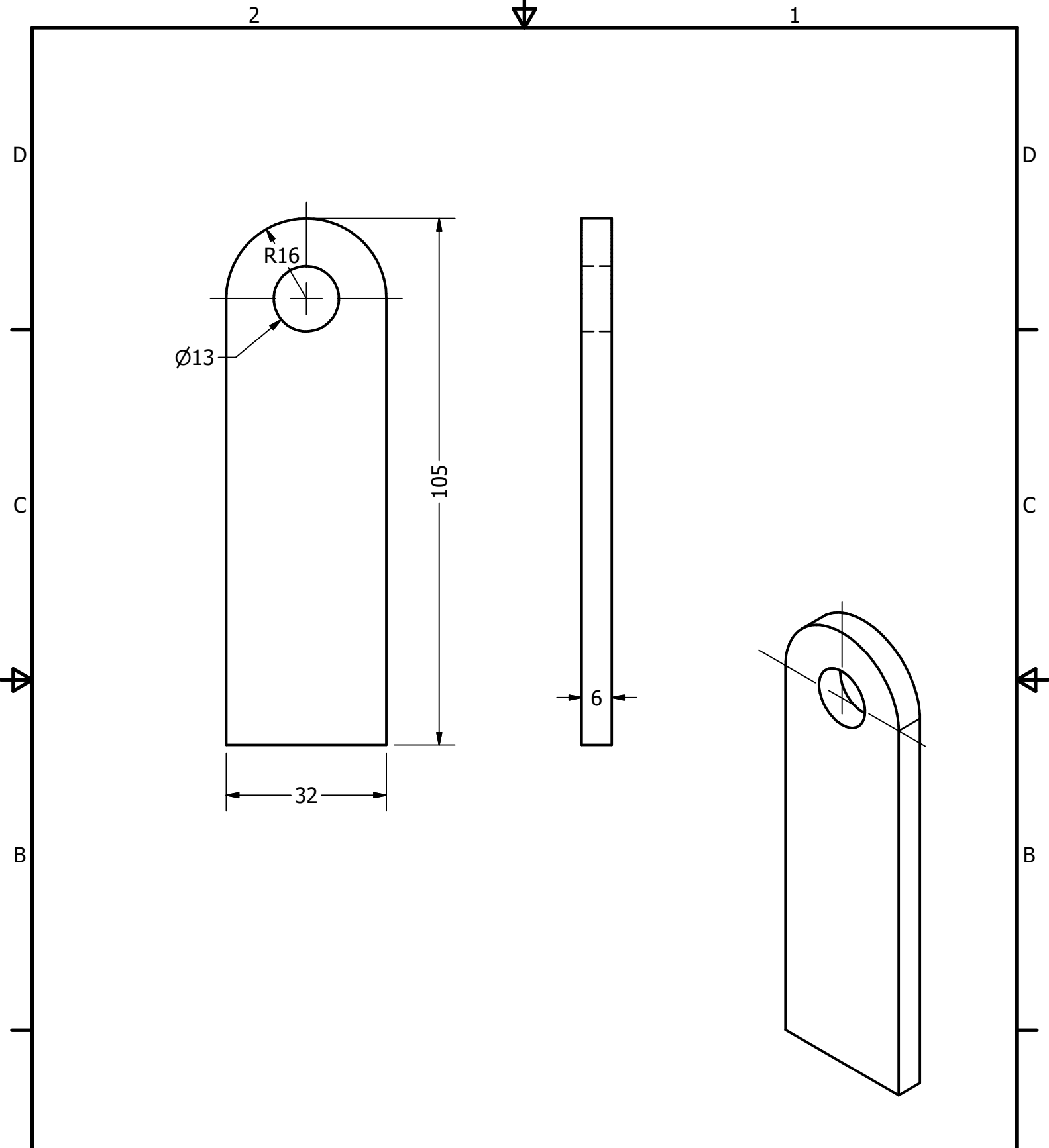



<b>PROJEKT</b> Windmuehlen-Pumpe		ERSTELLT VON D. Mosquera	GENEHMIGT VON D. Jaeger		
<b>TEIL-NAME</b> horizontale Pleuelstange		TEIL-CODE 3.2	DOKUMENTTYP part	WERKSTOFF Stahl C45	
UMGESTALTET VON	UNTERSTÜTZT VON	LIZENZ	DATEI-NAME	VERSION	MENGE
 OPEN SOURCE ECOLOGY GERMANY	 <b>E.ON</b> <b>STIFTUNG</b>	CC BY-SA 4.0	oseg_wmp_sides-plank.ipt	1.0	
			SCALE 1 : 1	SEITE 27	DATE 28.02.21

2

1

D

D

C

C



B

B

A

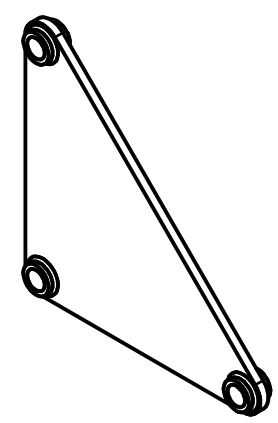
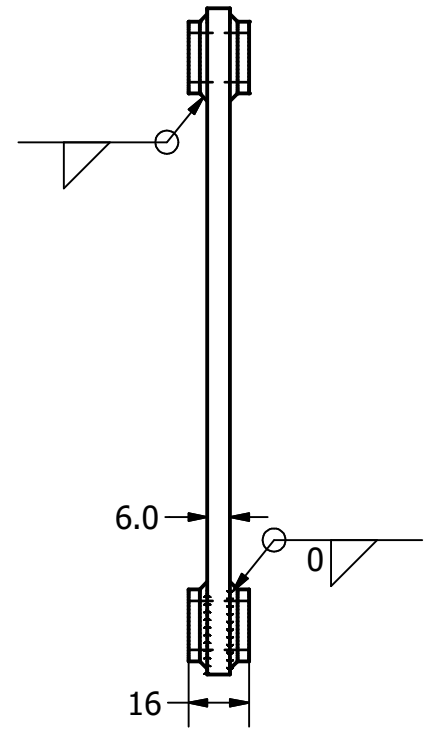
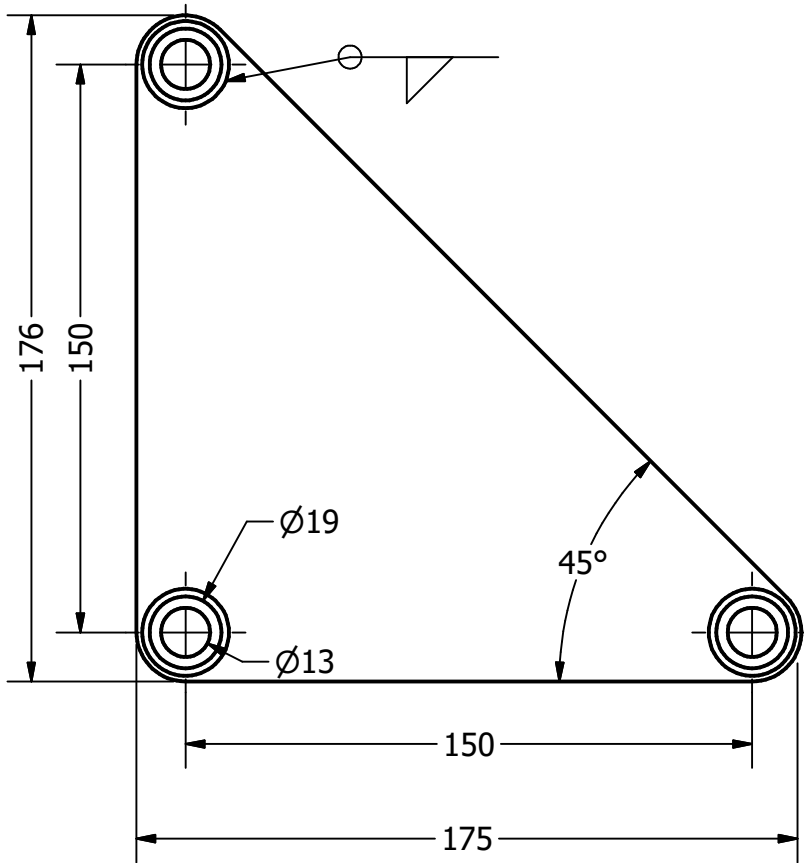
A



<b>PROJEKT</b> Windmuehlen-Pumpe		ERSTELLT VON D. Mosquera	GENEHMIGT VON D. Jaeger		
<b>TEIL-NAME</b> Umlenkhebel		TEIL-CODE 3.3	DOKUMENTTYP part	WERKSTOFF Stahl C45	
UMGESTALTET VON  OPEN SOURCE ECOLOGY GERMANY	UNTERSTÜTZT VON  STIFTUNG	LIZENZ CC BY-SA 4.0	DATEI-NAME oseg_wmp_bell-crank.ipt	VERSION 1.0	MENGE
			SCALE 1 / 2	SEITE 28	DATE 28.02.21

2

1





2

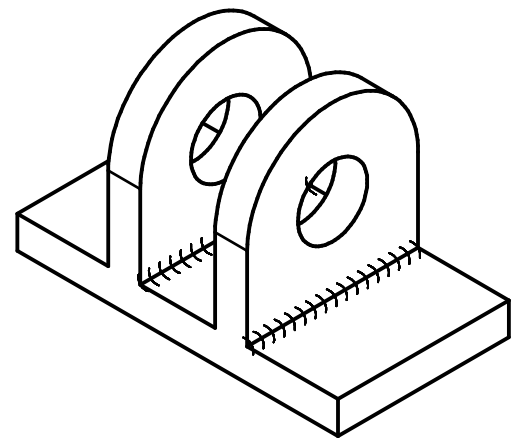
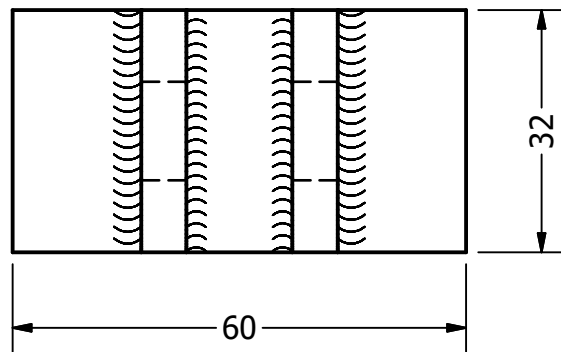
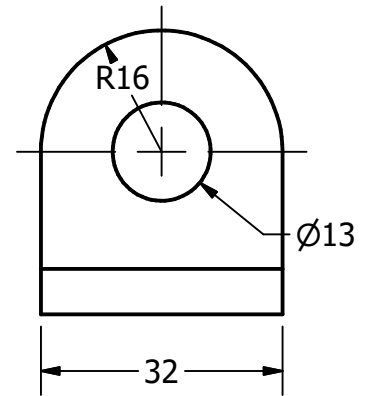
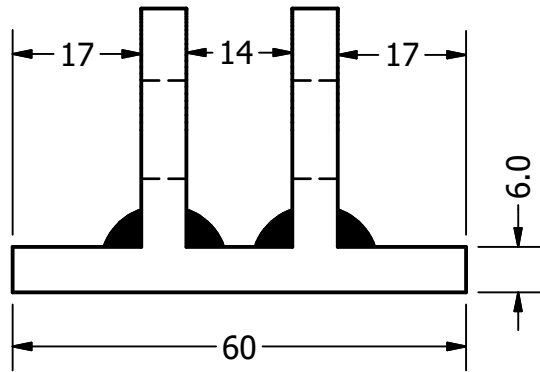

1





<b>PROJEKT</b> Windmuehlen-Pumpe		<b>ERSTELLT VON</b> D. Mosquera		<b>GENEHMIGT VON</b> D. Jaeger	
<b>TEIL-NAME</b> Schwenkplatte		<b>TEIL-CODE</b> 3.4		<b>DOKUMENTTYP</b> part	
<b>UMGESTALTET VON</b>		<b>UNTERSTÜTZT VON</b>		<b>WERKSTOFF</b> Stahl C45	
 <small>OPEN SOURCE ECOLOGY GERMANY</small>		 <b>E.ON</b> <b>STIFTUNG</b>		<b>LIZENZ</b> CC BY-SA 4.0	
				<b>DATEI-NAME</b> oseg_wmp_pivot-plate.ipt	
				<b>VERSION</b> 1.0	
				<b>MENGE</b>	
				<b>SCALE</b> 1 : 1	
				<b>SEITE</b> 29	
				<b>DATE</b> 28.02.21	

2



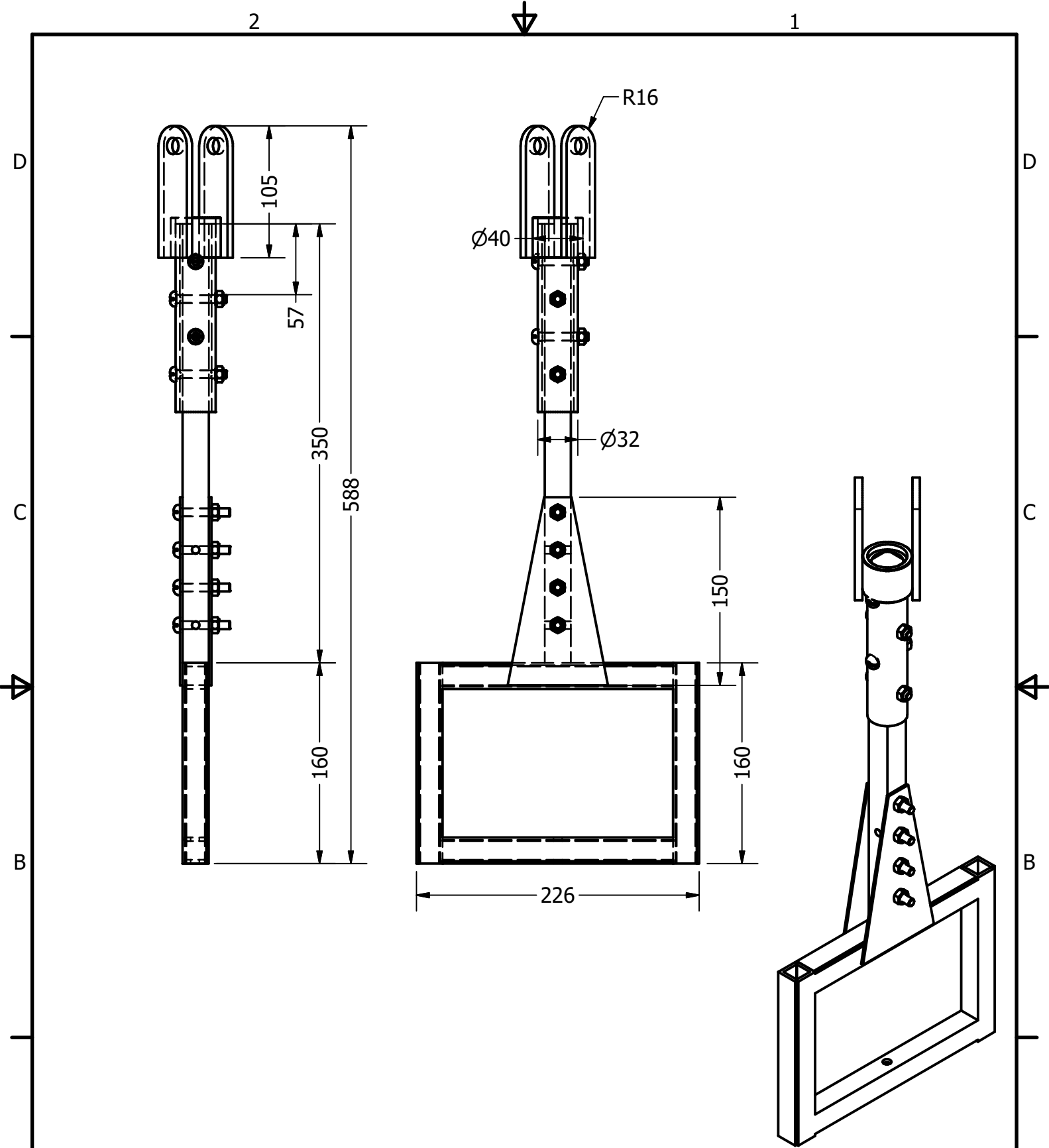

1



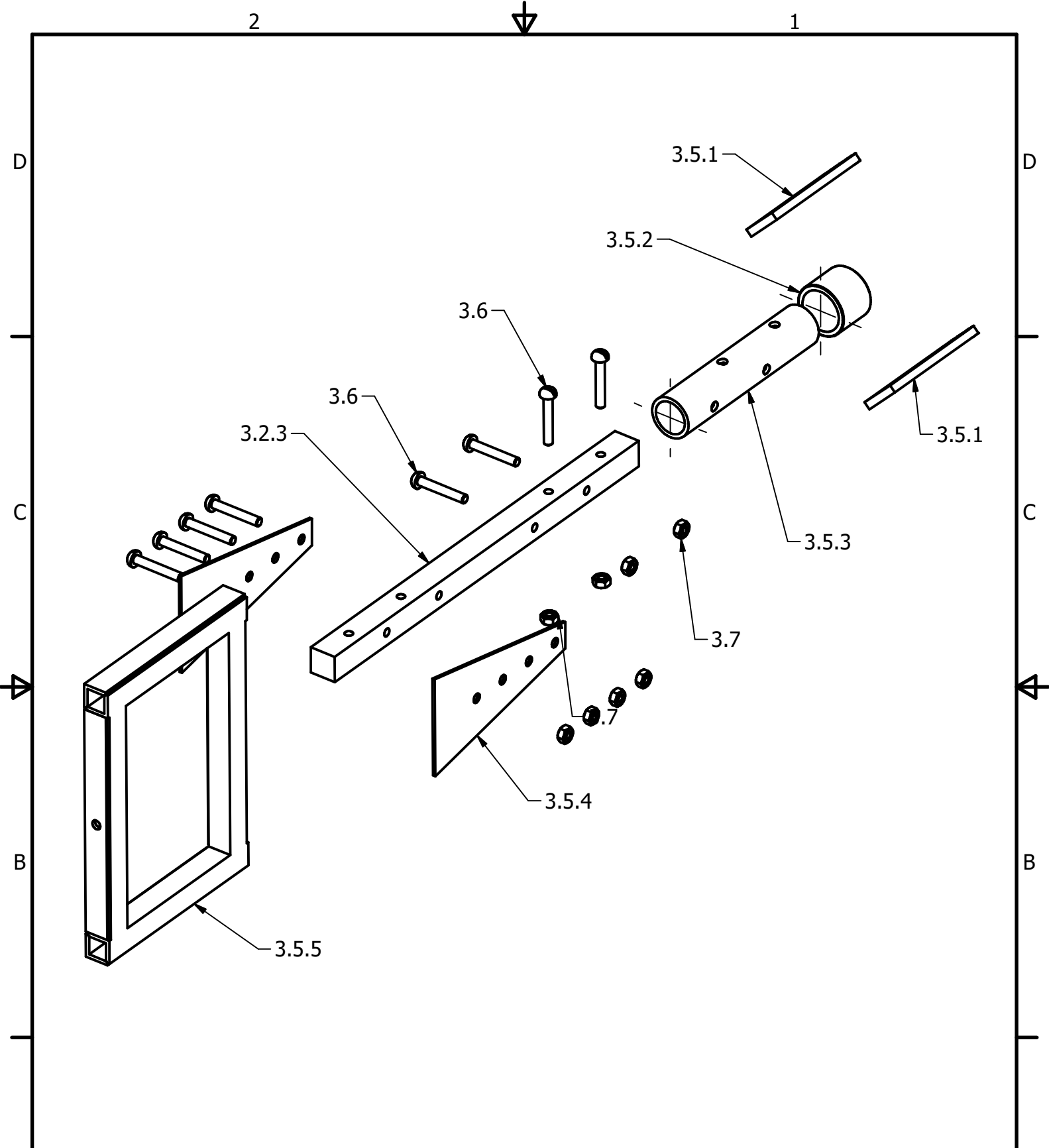

<b>PROJEKT</b> Windmuehlen-Pumpe		<b>ERSTELLT VON</b> D. Mosquera		<b>GENEHMIGT VON</b> D. Jaeger	
<b>TEIL-NAME</b> verstellbare Pumpstange Gabelkopf		<b>TEIL-CODE</b> 3.5		<b>DOKUMENTTYP</b> Assembly	
<b>UMGESTALTET VON</b>  OPEN SOURCE ECOLOGY GERMANY		<b>UNTERSTÜTZT VON</b>  E.ON STIFTUNG		<b>LIZENZ</b> CC BY-SA 4.0	
		<b>DATEI-NAME</b> wmp_adjustable-pumprod-forkend.iam		<b>VERSION</b> 1.0	
		<b>SCALE</b> 1 / 4		<b>MENGE</b> 30	
				<b>DATE</b> 28.02.21	

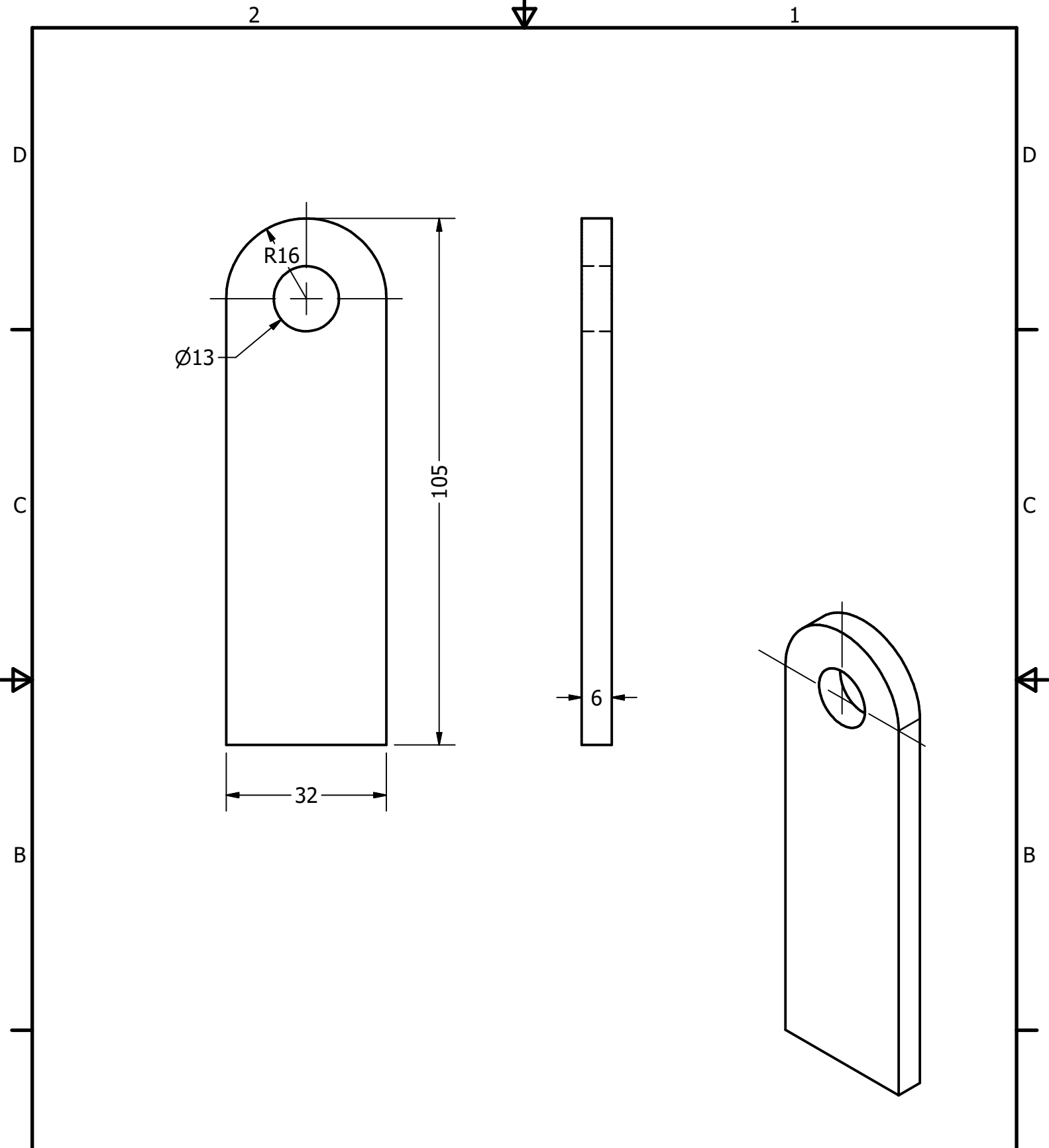

<b>PROJEKT</b> Windmuehlen-Pumpe		<b>ERSTELT VON</b> D. Mosquera		<b>GENEHMIGT VON</b> D. Jaeger	
<b>TEIL-NAME</b> horizontale Pleuelstange		<b>TEIL-CODE</b> 3.2		<b>DOKUMENTTYP</b> Assembly	
<b>UMGESTALTET VON</b>		<b>UNTERSTÜTZT VON</b>		<b>WERKSTOFF</b>	
 OPEN SOURCE ECOLOGY GERMANY		 E.ON STIFTUNG		<b>LIZENZ</b> CC BY-SA 4.0	
				<b>DATEI-NAME</b> wmp_adjustable-pumprod-forker.diam 1.0	
				<b>VERSION</b> 1.0	
				<b>MENGE</b>	
				<b>SCALE</b> 1 / 3.5	
				<b>SEITE</b> 31	
				<b>DATE</b> 28.02.21	



<b>PROJEKT</b> Windmuehlen-Pumpe		ERSTELLT VON D. Mosquera	GENEHMIGT VON D. Jaeger		
<b>TEIL-NAME</b> Halterung aus Blech		TEIL-CODE 3.5.1	DOKUMENTTYP part	WERKSTOFF Stahl C45	
UMGESTALTET VON	UNTERSTÜTZT VON	LIZENZ	DATEI-NAME	VERSION	MENGE
 <small>OPEN SOURCE ECOLOGY GERMANY</small>	 <b>E.ON STIFTUNG</b>	CC BY-SA 4.0	oseg_wmp_sides-plank.ipt	1.0	
				SCALE 1 : 1	SEITE 32



2

1

D

D

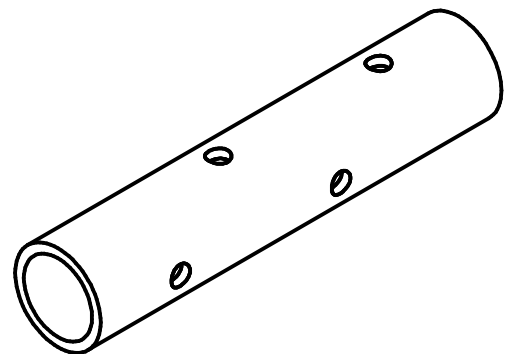
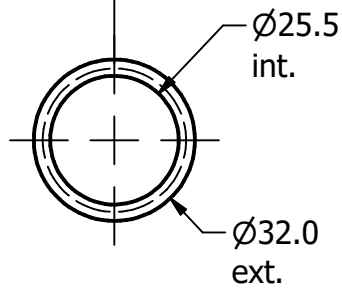
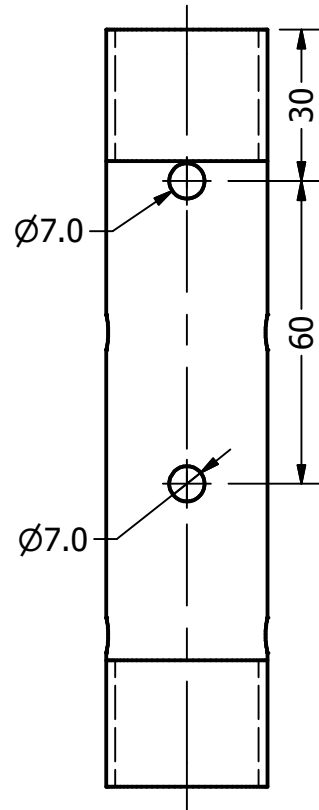
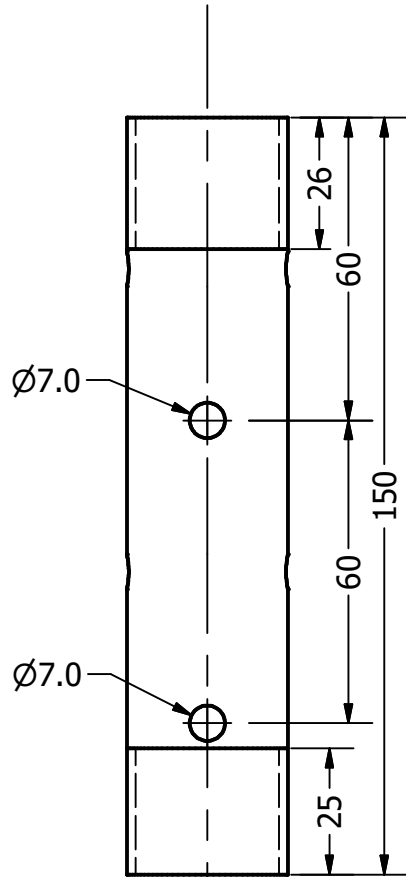

C



C

B

B

A

A

<b>PROJEKT</b> Windmuehlen-Pumpe		<b>ERSTELLT VON</b> D. Mosquera		<b>GENEHMIGT VON</b> D. Jaeger	
<b>TEIL-NAME</b> Wasserrohr 1 "x150		<b>TEIL-CODE</b> 3.5.3		<b>DOKUMENTTYP</b> part	
<b>UMGESTALTET VON</b>		<b>UNTERSTÜTZT VON</b>		<b>WERKSTOFF</b> ASTM A36	
 <small>OPEN SOURCE ECOLOGY GERMANY</small>		 <b>E.ON</b> <b>STIFTUNG</b>		<b>LIZENZ</b> CC BY-SA 4.0	
				<b>DATEI-NAME</b> oseg_wmp_water-pipe-1x150.ipt	
				<b>VERSION</b> 1.0	
				<b>MENGE</b>	
				<b>SCALE</b> 1 : 1,5	
				<b>SEITE</b> 33	
				<b>DATE</b> 28.02.21	

2

1



2

1

D

D

C

C

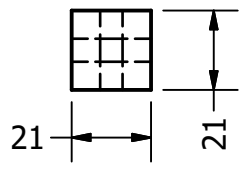
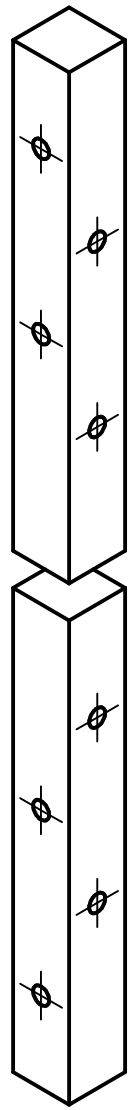
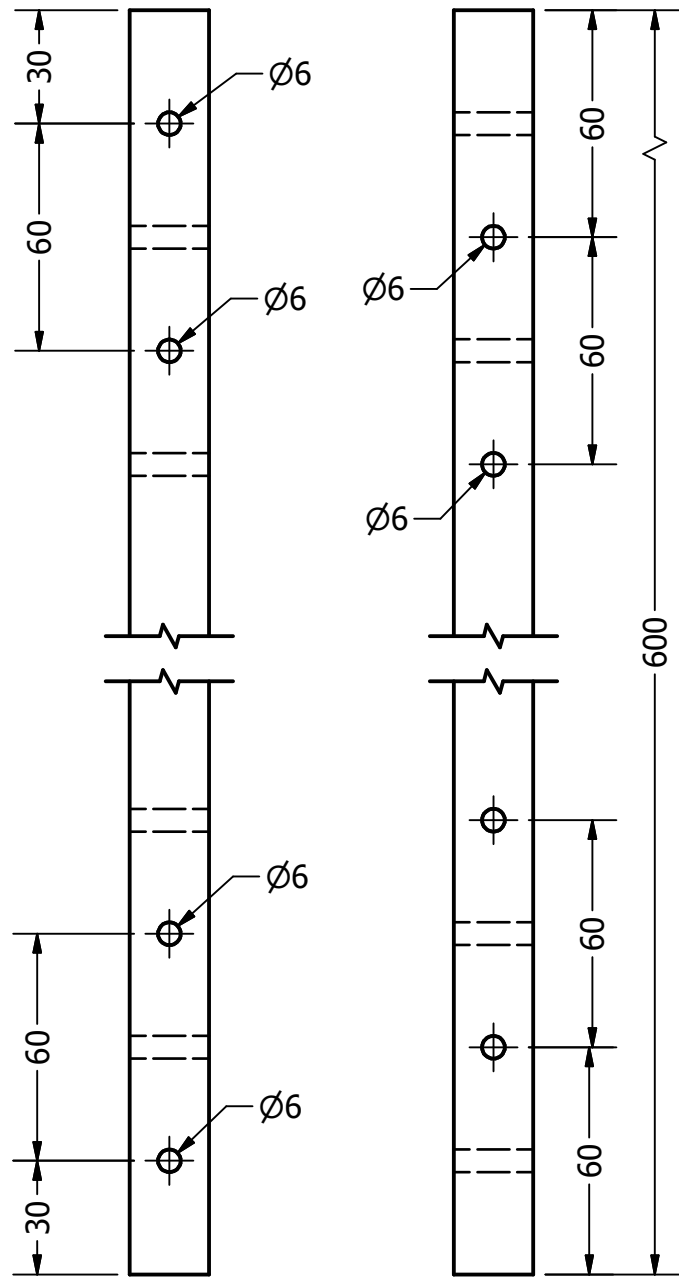

B

B



A

A



<b>PROJEKT</b> Windmuehlen-Pumpe		<b>ERSTELLT VON</b> D. Mosquera		<b>GENEHMIGT VON</b> D. Jaeger	
<b>TEIL-NAME</b> Stange vert 1x1x 600		<b>TEIL-CODE</b> 3.5.4		<b>DOKUMENTTYP</b> part	
<b>UMGESTALTET VON</b> 		<b>UNTERSTÜTZT VON</b> 		<b>LIZENZ</b> CC BY-SA 4.0	
				<b>DATEI-NAME</b> oseg_wmp_rod-horizont-1x1x600.ipt	
				<b>VERSION</b> 1.0	
				<b>MENGE</b> 	
				<b>SCALE</b> 1 / 2	
				<b>SEITE</b> 34	
				<b>DATE</b> 28.02.21	

2

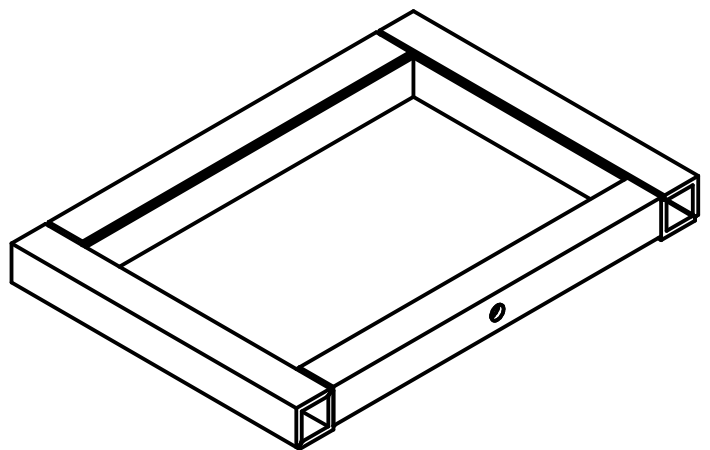
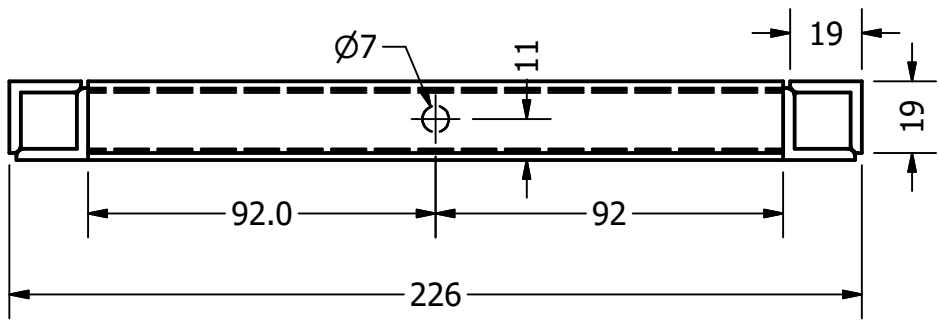
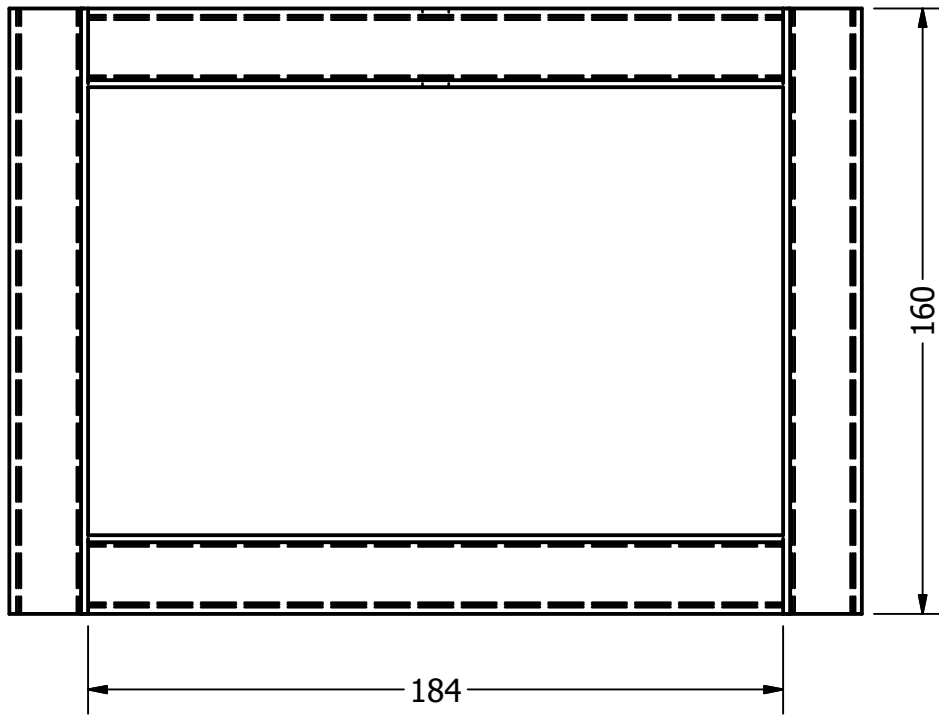

1



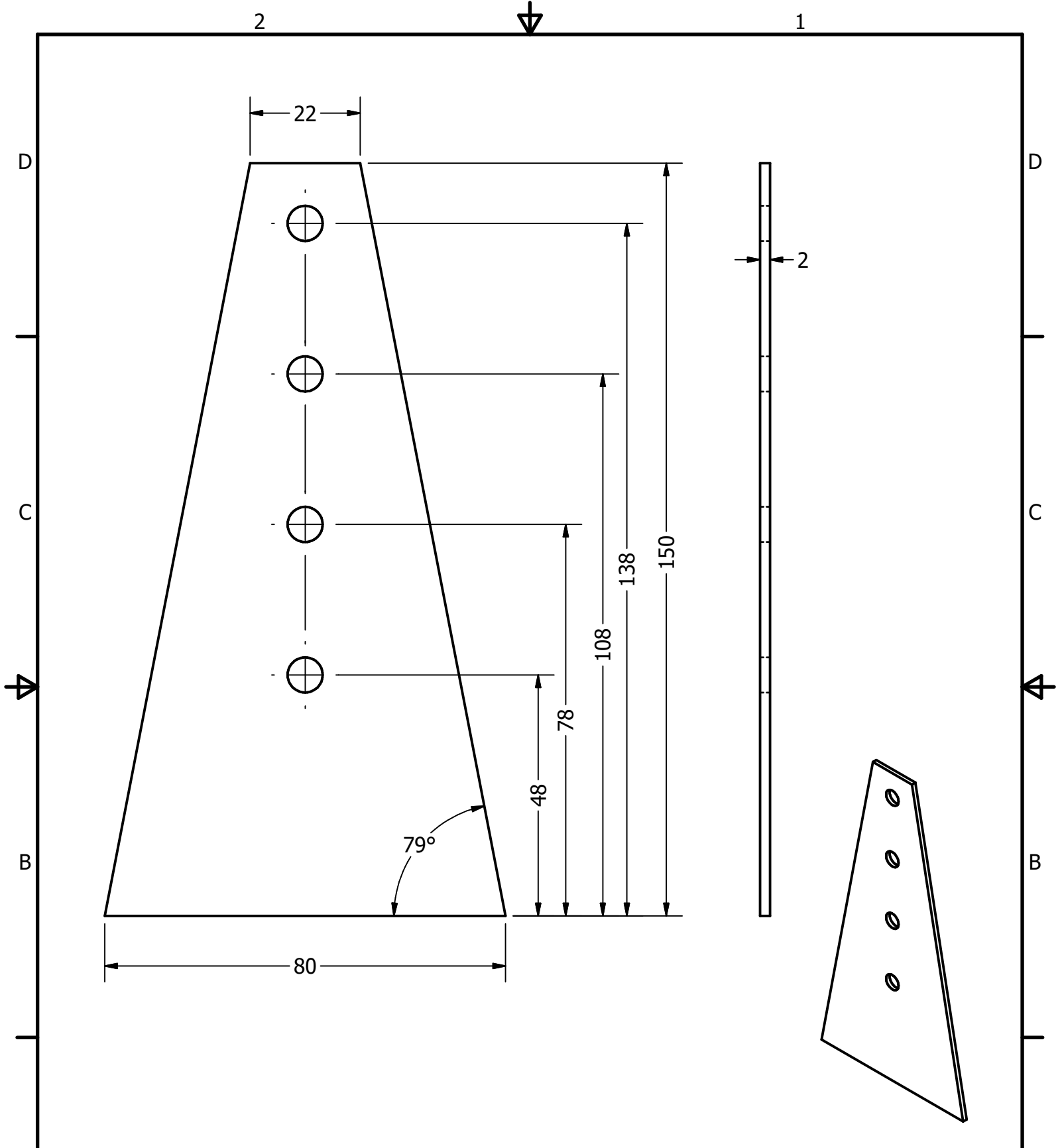

<b>PROJEKT</b> Windmuehlen-Pumpe		ERSTELLT VON D. Mosquera	GENEHMIGT VON D. Jaeger		
<b>TEIL-NAME</b> Bügel		TEIL-CODE 3.5.5	DOKUMENTTYP Assembly	WERKSTOFF ASTM-A36	
UMGESTALTET VON  OPEN SOURCE ECOLOGY GERMANY	UNTERSTÜTZT VON  <b>STIFTUNG</b>	LIZENZ CC BY-SA 4.0	DATEI-NAME oseg_wmp_stirrup.ipt	VERSION 1.0	MENGE
			SCALE 1 / 2	SEITE 35	DATE 28.02.21



<b>PROJEKT</b> Windmuehlen-Pumpe		<b>ERSTELLT VON</b> D. Mosquera		<b>GENEHMIGT VON</b> D. Jaeger	
<b>TEIL-NAME</b> Bügel aus Blech		<b>TEIL-CODE</b> 3.5.6		<b>DOKUMENTTYP</b> part	
<b>UMGESTALTET VON</b>		<b>UNTERSTÜTZT VON</b>		<b>WERKSTOFF</b>	
 <small>OPEN SOURCE ECOLOGY GERMANY</small>		 <b>STIFTUNG</b>		<b>Stahl C45</b>	
<b>LIZENZ</b> CC BY-SA 4.0		<b>DATEI-NAME</b> oseg_wmp_sheet-metal2-bracket.ipt		<b>VERSION</b> 1.0	
		<b>SCALE</b> 1 : 1		<b>MENGE</b> 36	
				<b>DATE</b> 28.02.21	

2



1

D

D

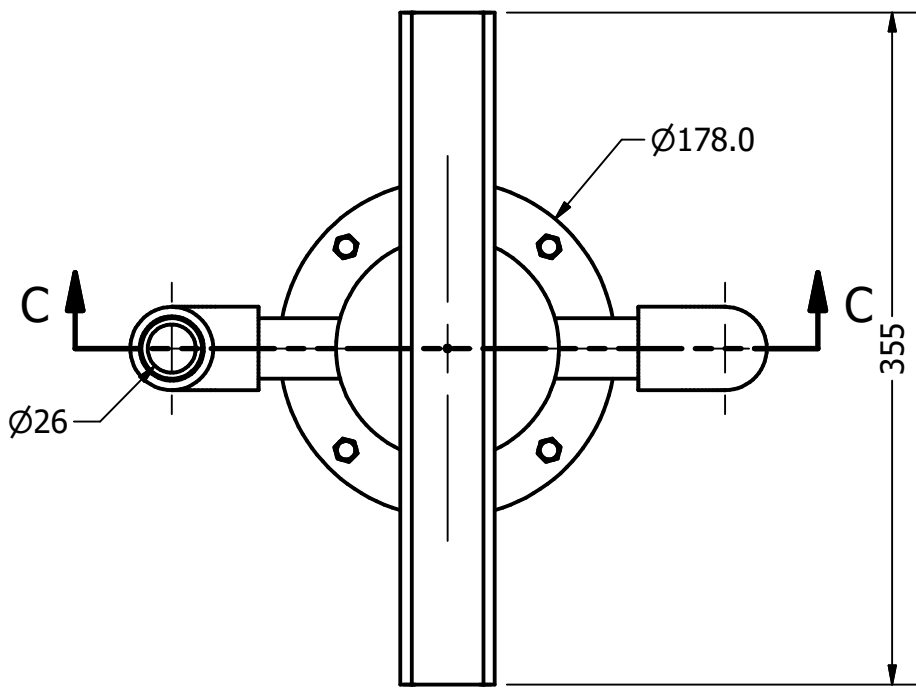

Ø26

Ø178.0

355

C

C

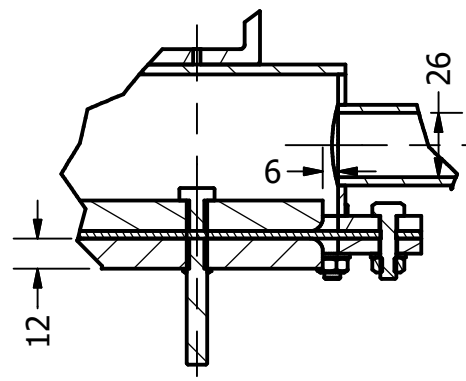

12

6

26

DETAIL 8

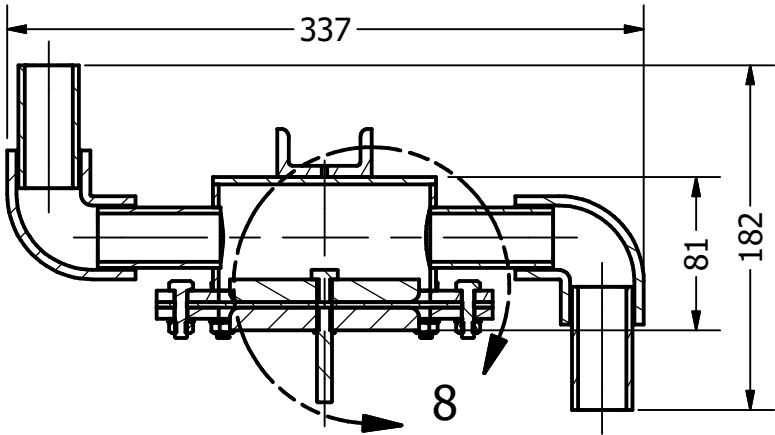

337

81

182

8

SECTION C-C

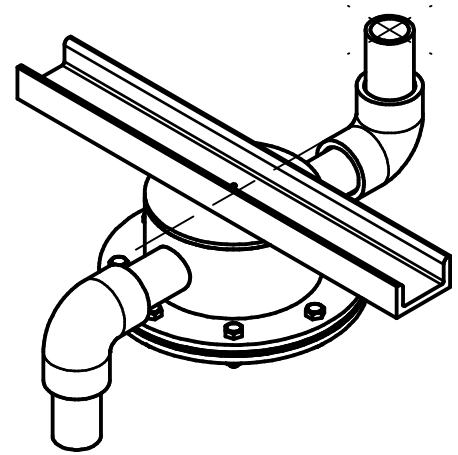

B

B



A

A



<b>PROJEKT</b> Windmuehlen-Pumpe		<b>ERSTELT VON</b> D. Mosquera		<b>GENEHMIGT VON</b> D. Jaeger	
<b>TEIL-NAME</b> Pumpe		<b>TEIL-CODE</b> 4		<b>DOKUMENTTYP</b> Assembly	
<b>UMGESTALTET VON</b> 		<b>UNTERSTÜTZT VON</b>  <b>STIFTUNG</b>		<b>LIZENZ</b> CC BY-SA 4.0	
				<b>DATEI-NAME</b> oseg_wmp_pump.iam	
				<b>VERSION</b> 1.0	
				<b>MENGE</b>	
				<b>SCALE</b> 1 / 4	
				<b>SEITE</b> 37	
				<b>DATE</b> 28.02.21	

2

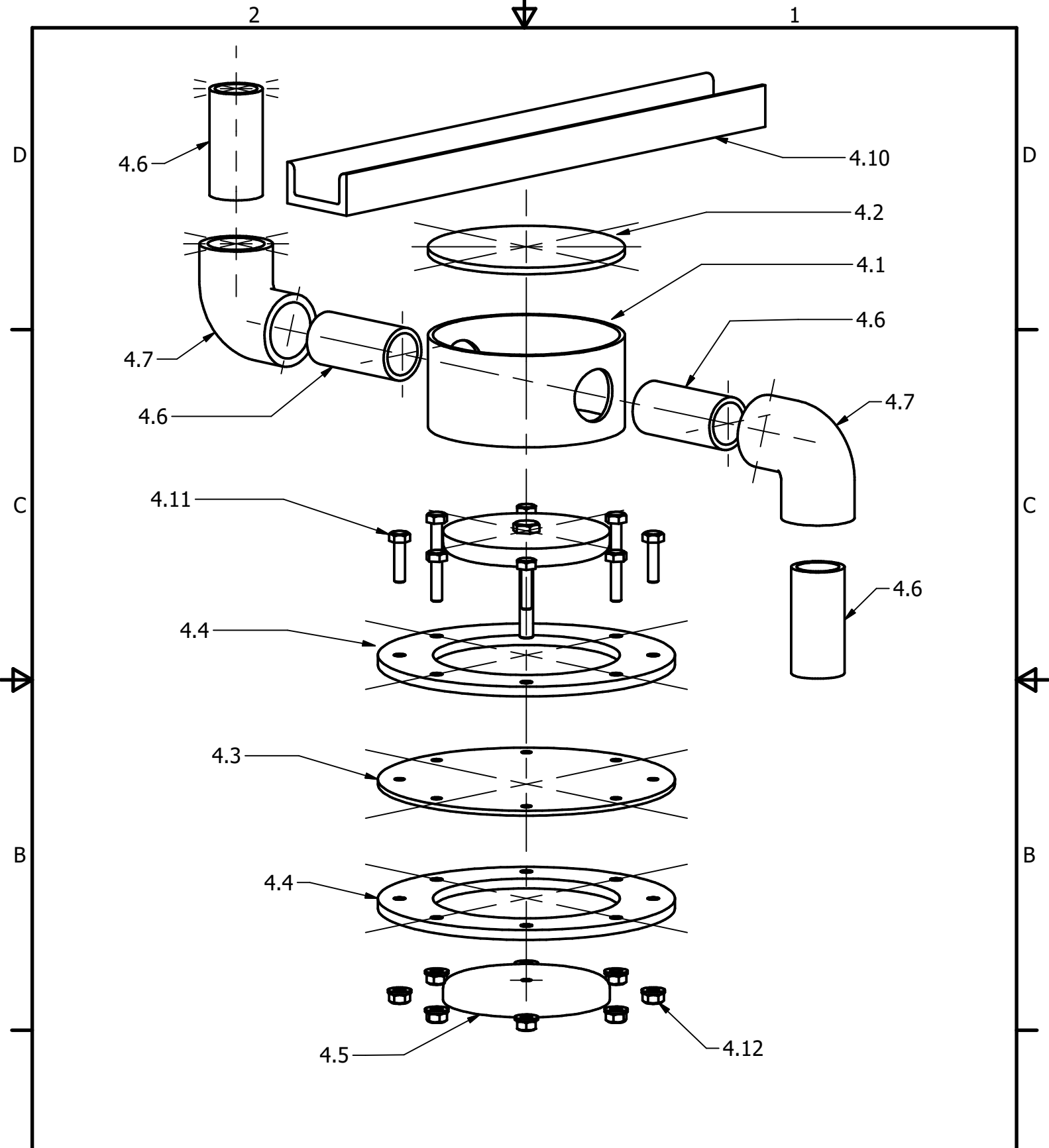

1



<b>PROJEKT</b> Windmuehlen-Pumpe		<b>ERSTELT VON</b> D. Mosquera		<b>GENEHMIGT VON</b> D. Jaeger	
<b>TEIL-NAME</b> Pumpe		<b>TEIL-CODE</b> 4		<b>DOKUMENTTYP</b> Assembly	
<b>UMGESTALTET VON</b>  OPEN SOURCE ECOLOGY GERMANY		<b>UNTERSTÜTZT VON</b>  E.ON STIFTUNG		<b>LIZENZ</b> CC BY-SA 4.0	
				<b>DATEI-NAME</b> oseg_wmp_pump.iam	
				<b>VERSION</b> 1.0	
				<b>MENGE</b> 1	
				<b>SCALE</b> 1 / 3	
				<b>SEITE</b> 38	
				<b>DATE</b> 28.02.21	

2



1

2

1

D

D

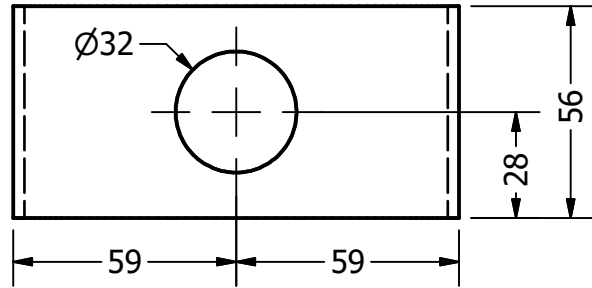

C

C

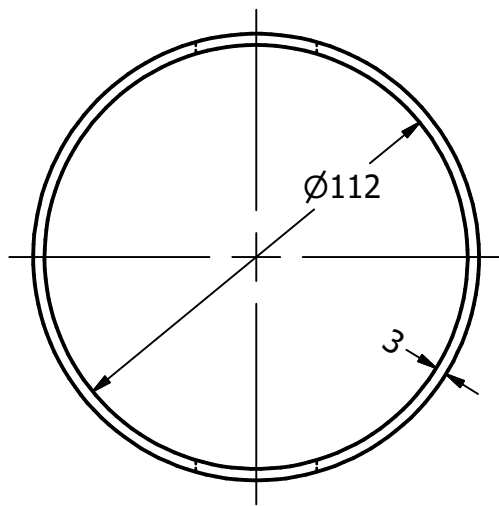

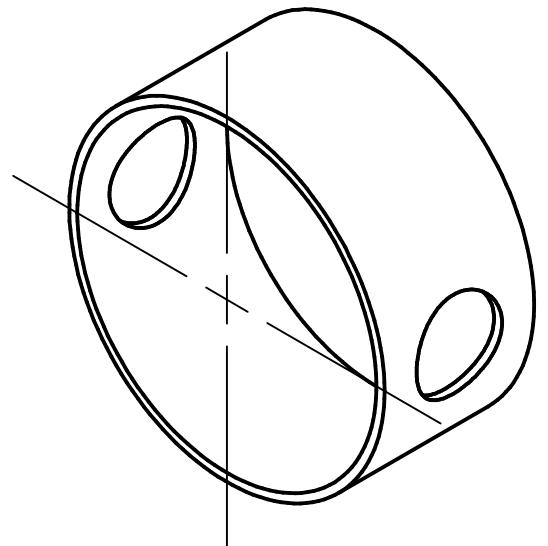

B

B



A

A

<b>PROJEKT</b> Windmuehlen-Pumpe		<b>ERSTELT VON</b> D. Mosquera		<b>GENEHMIGT VON</b> D. Jaeger	
<b>TEIL-NAME</b> Pumpenkörper O-Ring		<b>TEIL-CODE</b> 4.1		<b>DOKUMENTTYP</b> part	
<b>UMGESTALTET VON</b>  OPEN SOURCE ECOLOGY GERMANY		<b>UNTERSTÜTZT VON</b>  <b>STIFTUNG</b>		<b>WERKSTOFF</b> Stahl C45	
<b>LIZENZ</b> CC BY-SA 4.0		<b>DATEI-NAME</b> oseg_wmp_pumpbody.ipt		<b>VERSION</b> 1.0	
		<b>SCALE</b> 1 / 2		<b>MENGE</b> SEITE 39	
				<b>DATE</b> 28.02.21	

2

1



2

1

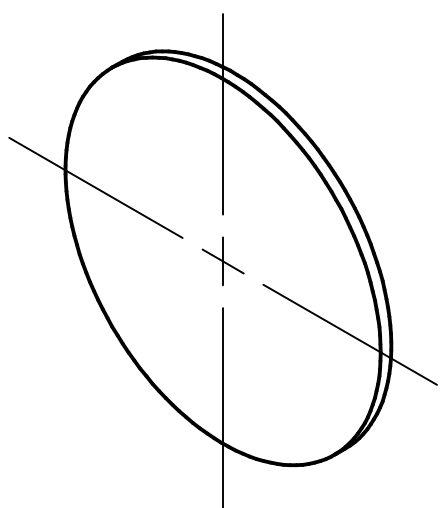
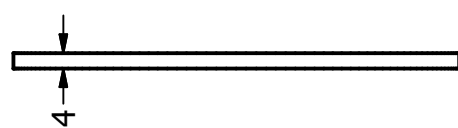
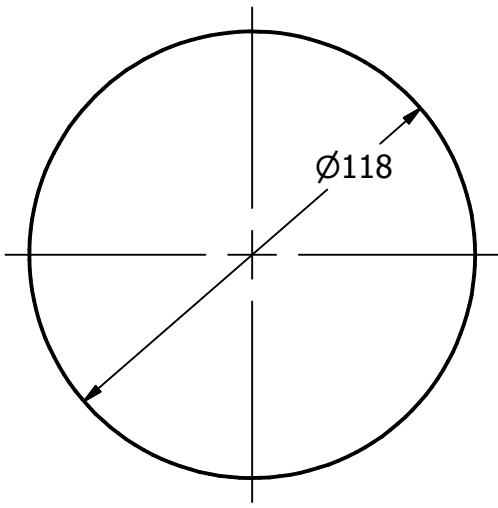



2

1

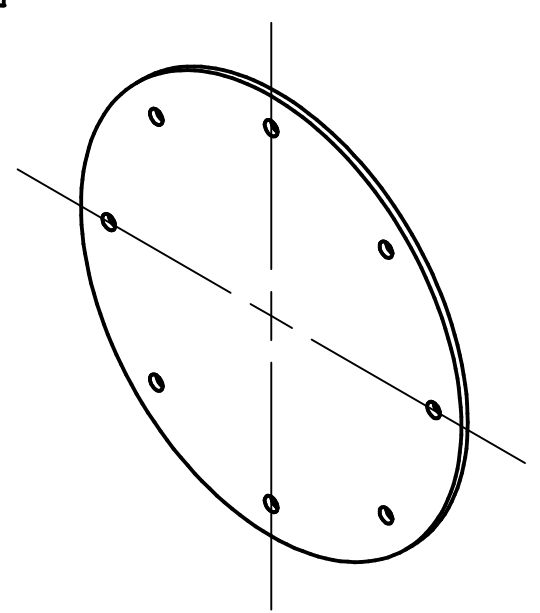
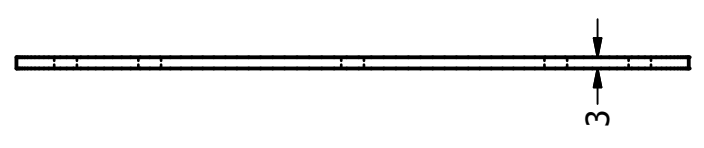
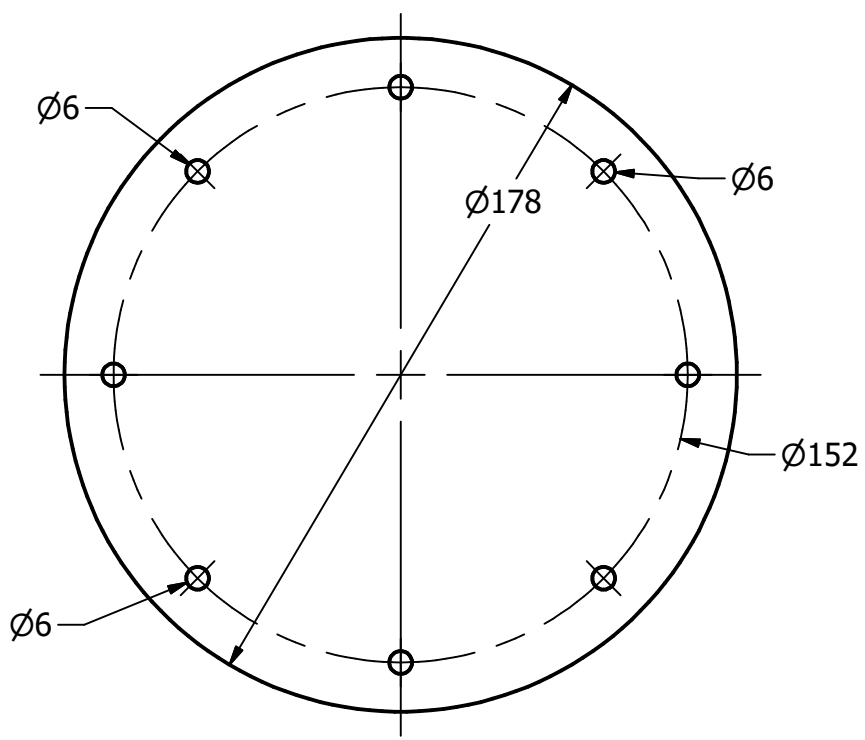

<b>PROJEKT</b> Windmuehlen-Pumpe		<b>ERSTELLT VON</b> D. Mosquera		<b>GENEHMIGT VON</b> D. Jaeger	
<b>TEIL-NAME</b> Pumpenkörperscheibe		<b>TEIL-CODE</b> 4.2		<b>DOKUMENTTYP</b> part	
<b>UMGESTALTET VON</b>		<b>UNTERSTÜTZT VON</b>		<b>WERKSTOFF</b> Stahl C45	
 <small>OPEN SOURCE ECOLOGY GERMANY</small>		 <b>E.ON</b> <b>STIFTUNG</b>		<b>LIZENZ</b> CC BY-SA 4.0	
				<b>DATEI-NAME</b> oseg_wmp_pumpbody-disk.ipt	
				<b>MENGE</b>	
				<b>SCALE</b> 1 / 2	
				<b>SEITE</b> 40	
				<b>DATE</b> 28.02.21	





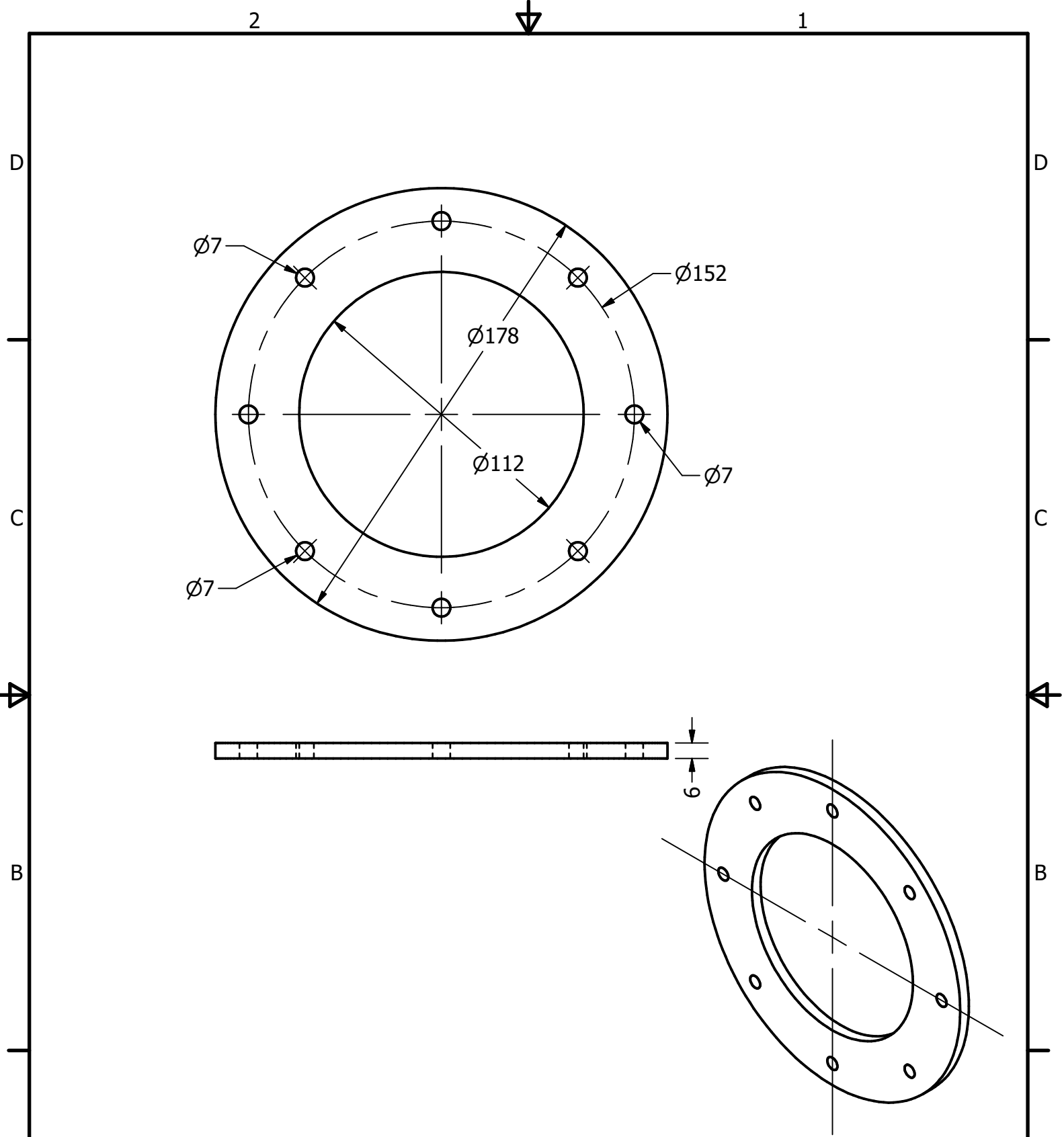

<b>PROJEKT</b> Windmuehlen-Pumpe		<b>ERSTELLT VON</b> D. Mosquera		<b>GENEHMIGT VON</b> D. Jaeger	
<b>TEIL-NAME</b> Gummi-Diaphragma		<b>TEIL-CODE</b> 4.3		<b>DOKUMENTTYP</b> part	
<b>UMGESTALTET VON</b>		<b>UNTERSTÜTZT VON</b>		<b>WERKSTOFF</b> Gummi	
 OPEN SOURCE ECOLOGY GERMANY		 E.ON STIFTUNG		<b>LIZENZ</b> CC BY-SA 4.0	
				<b>DATEI-NAME</b> oseg_wmp_rubber-diafphragm.ip	
				<b>MENGE</b>	
				<b>DATE</b> 28.02.21	
				<b>SCALE</b> 1 / 2	
				<b>SEITE</b> 41	

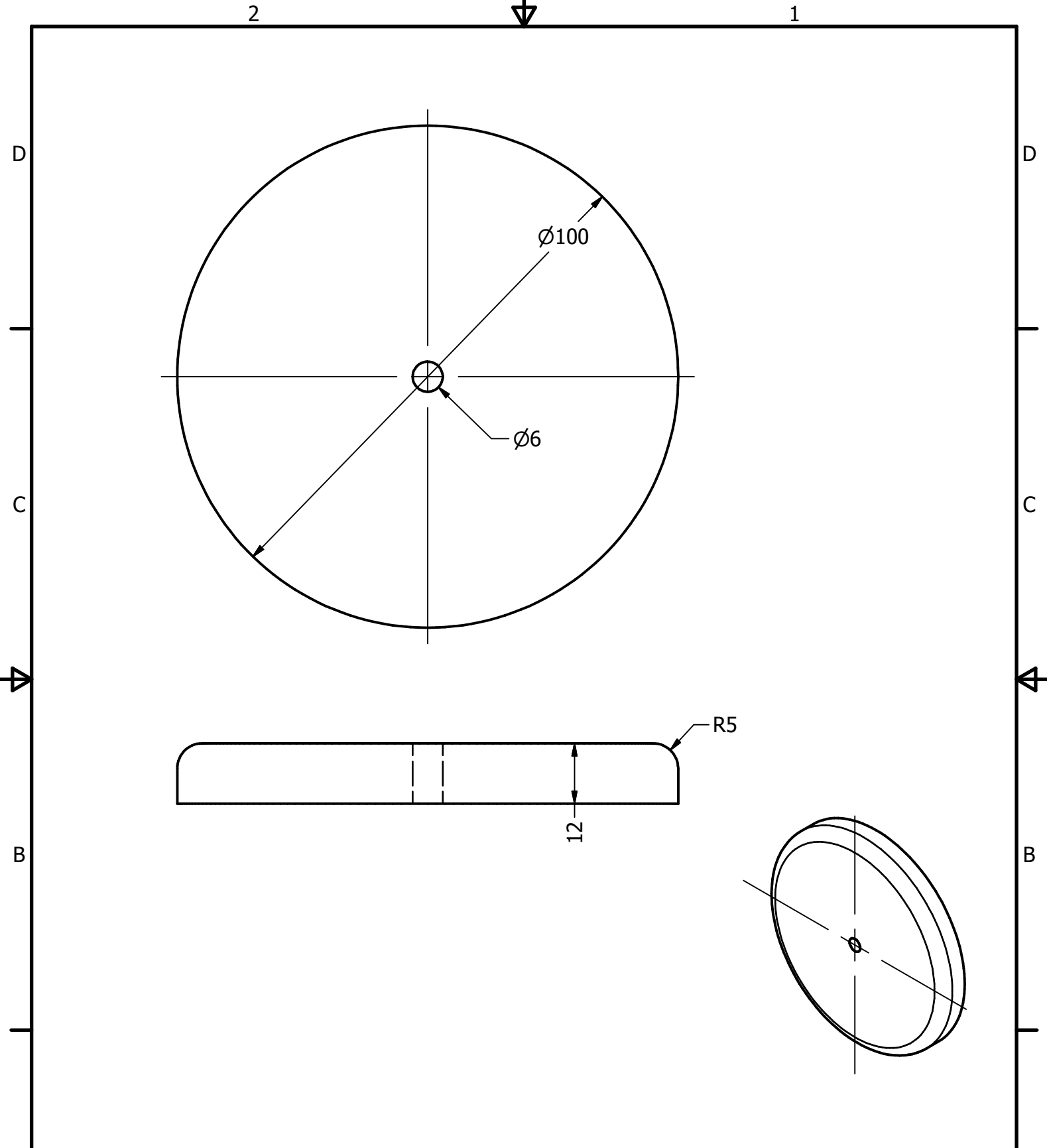

<b>PROJEKT</b> Windmuehlen-Pumpe		<b>ERSTELT VON</b> D. Mosquera		<b>GENEHMIGT VON</b> D. Jaeger	
<b>TEIL-NAME</b> Flanschring		<b>TEIL-CODE</b> 4.4		<b>DOKUMENTTYP</b> part	
<b>UMGESTALTET VON</b>  OPEN SOURCE ECOLOGY GERMANY		<b>UNTERSTÜTZT VON</b>  <b>E.ON</b> <b>STIFTUNG</b>		<b>WERKSTOFF</b> Stahl C45	
<b>LIZENZ</b> CC BY-SA 4.0		<b>DATEI-NAME</b> oseg_wmp_flanche-ring.ipt		<b>VERSION</b> 1.0	
		<b>SCALE</b> 1 / 2		<b>MENGE</b> 1	
				<b>SEITE</b> 42	
				<b>DATE</b> 28.02.21	



<b>PROJEKT</b> Windmuehlen-Pumpe		ERSTELLT VON D. Mosquera	GENEHMIGT VON D. Jaeger		
<b>TEIL-NAME</b> Abstandhalter		TEIL-CODE 4.5	DOKUMENTTYP part	WERKSTOFF Holz	
UMGESTALTET VON	UNTERSTÜTZT VON	LIZENZ	DATEI-NAME	VERSION	MENGE
 OPEN SOURCE ECOLOGY GERMANY	 <b>E.ON</b> <b>STIFTUNG</b>	CC BY-SA 4.0	oseg_wmp_spacer.ipt	1.0	
			SCALE 1 : 1	SEITE 43	DATE 28.02.21

2

1

D

D

C

C

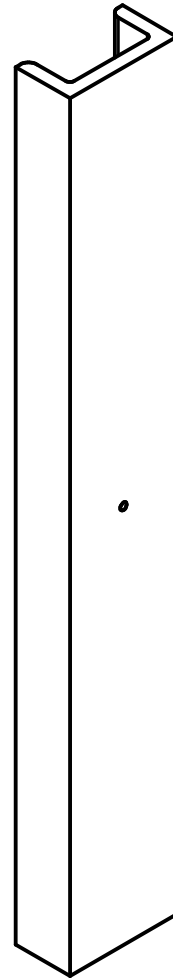
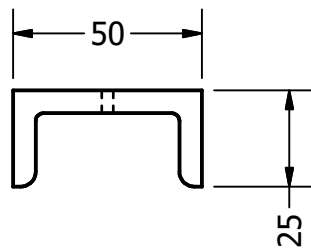
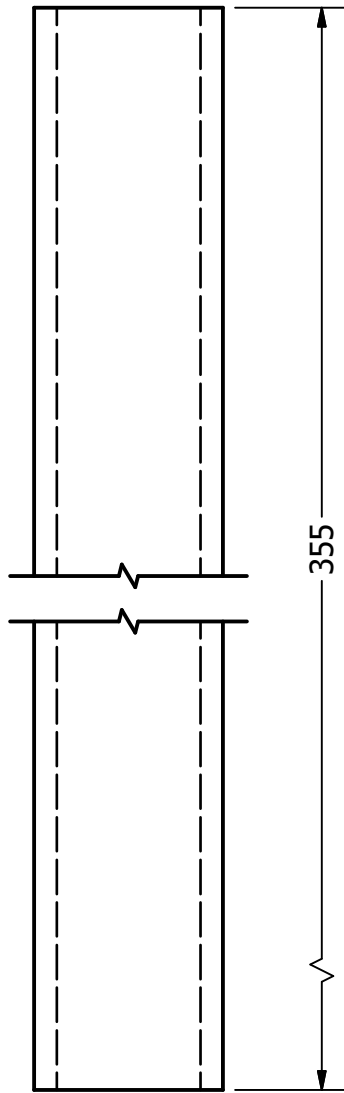

B

B



A

A

<b>PROJEKT</b> Windmuehlen-Pumpe		<b>ERSTELLT VON</b> D. Mosquera		<b>GENEHMIGT VON</b> D. Jaeger	
<b>TEIL-NAME</b> Montageschiene - U25x50		<b>TEIL-CODE</b> 4.10		<b>DOKUMENTTYP</b> part	
<b>UMGESTALTET VON</b> 		<b>UNTERSTÜTZT VON</b>  <b>STIFTUNG</b>		<b>WERKSTOFF</b> ASTM A36	
<b>LIZENZ</b> CC BY-SA 4.0		<b>DATEI-NAME</b> oseg_wmp_mounting-bar.ipt		<b>VERSION</b> 1.0	
		<b>SCALE</b> 1 / 2		<b>MENGE</b> 1	
				<b>SEITE</b> 44	
				<b>DATE</b> 28.02.21	

2

1

