

C (0.5 : 1)

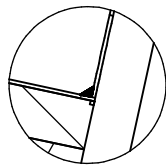

D (0.5 : 1)

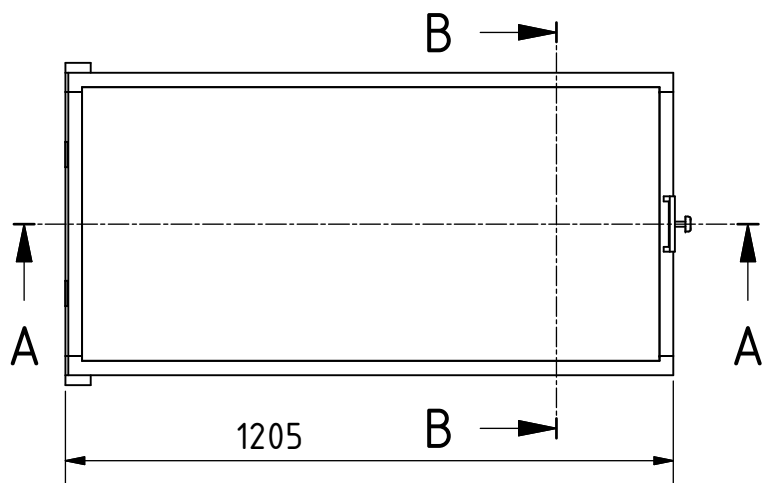
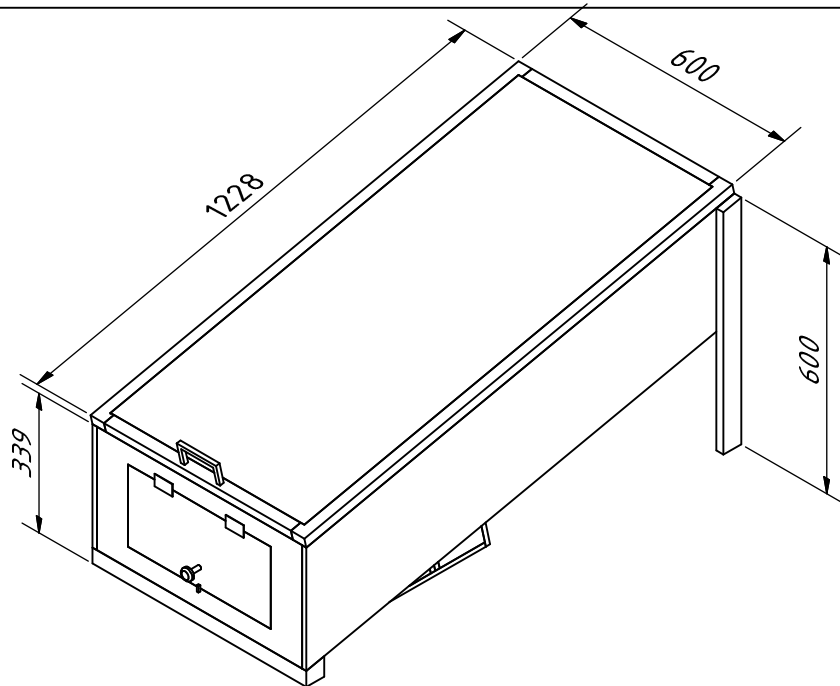
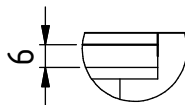

A-A

Front

Back

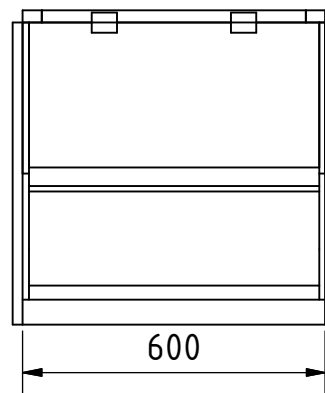
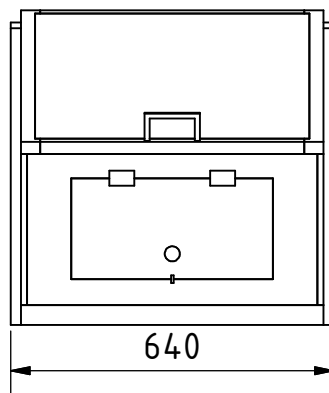

B-B

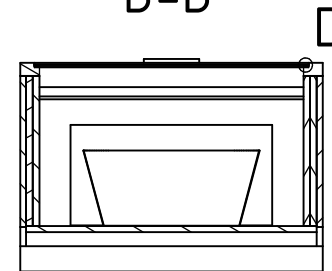

D

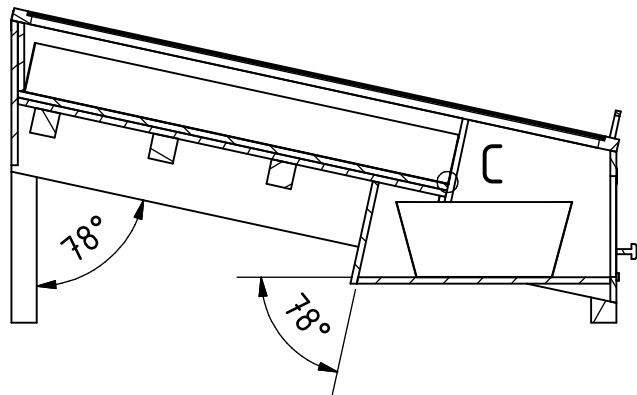

Note: All units in mm.

PROJECT	CREATED BY	APPROVED BY	DATE	VERSION
Solar Wax Melter	J. Zeron	A. Morillo	10/08/2021	1.0
PART NAME	FILE NAME	POS		
3d views	uoc_swm_solar-wax-melter.iam	A1		
DEVELOPED BY	REDESIGNED BY	DOC. TYPE	MATERIAL	QUANTITY
University of California	OHO e.V.	Assembly		
		LICENCE	SCALE	SHEET
		CC-BY-SA 4.0	1:15	1 /17

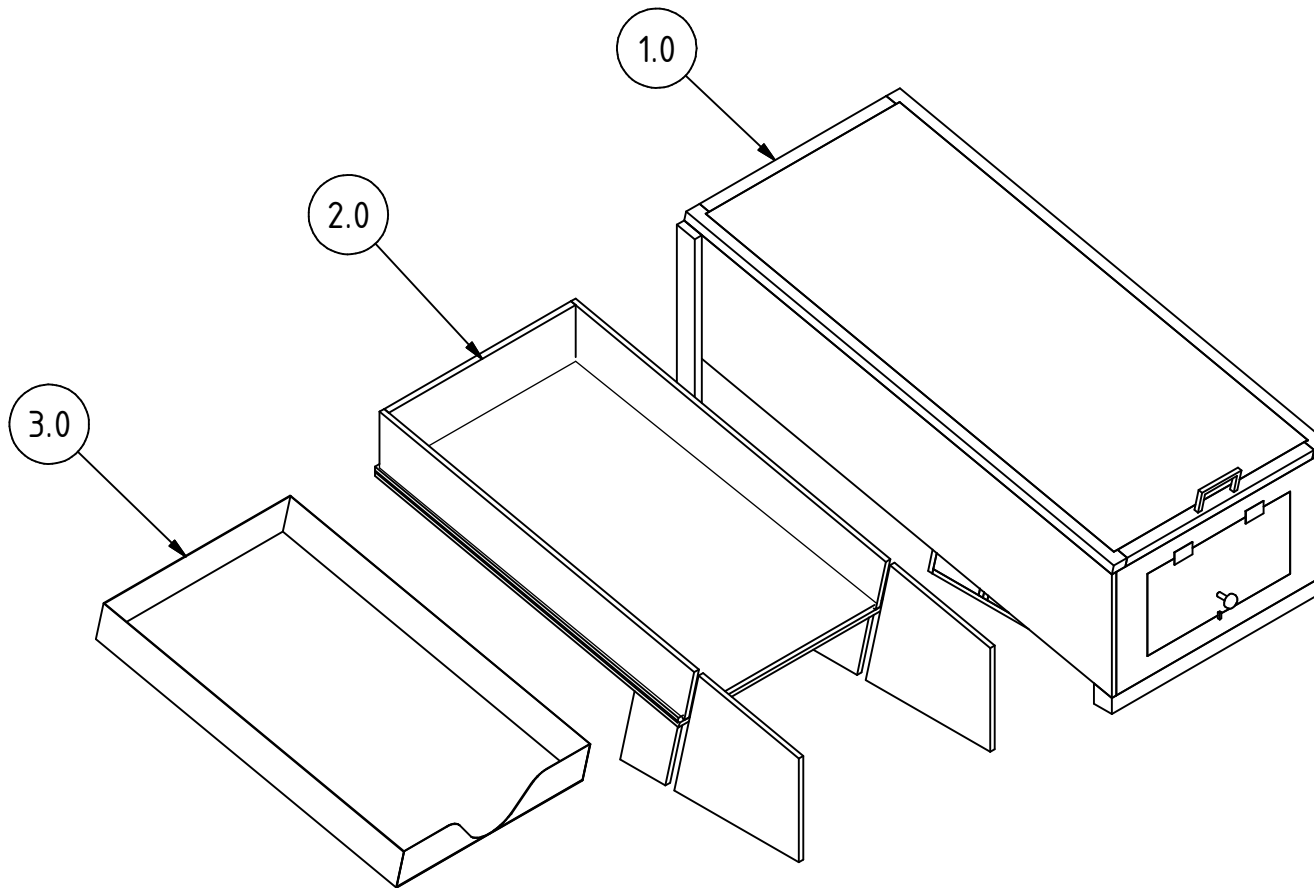

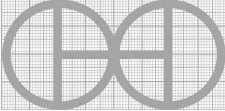
PROJECT	CREATED BY	APPROVED BY	DATE	VERSION
Solar Wax Melter	J. Zeron	A. Morillo	10/08/2021	1.0
PART NAME	FILE NAME			POS
Exploded 3d view	uoc_swm_solar-wax-melter.ipn			A2
DEVELOPED BY	REDESIGNED BY	DOC. TYPE	MATERIAL	QUANTITY
		Assembly		
University of California	OHO e.V.	LICENCE	SCALE	SHEET
		CC-BY-SA 4.0	1:25	2 /17

Parts list

POS	QTY	PART NAME	FILE NAME	PART TYPE	SPECIFICATIONS	SHEET
A1	-	3d views	uoc_swm_solar-wax-melter.iam	-	-	1
A2	-	Exploded 3d view	uoc_swm_solar-wax-melter.ipn	-	-	2
B1	-	Parts list	uoc_swm_solar-wax-melter.csv	-	-	3-4
1.0	-	External drawer	External drawer.ipn	-	-	5
1.1	2	Foot	Foot.ipt	Production	Hardwood 20mm	6
1.2	2	Side plank	Side plank.ipt	Production	Hardwood 12mm	7
1.3	3	Middle rail	-	Production	Hardwood 50x50x576mm	-
1.4	1	Botton plank	-	Production	Hardwood 576x12x503mm	-
1.5	1	Middle plank	-	Production	Hardwood 576x12x205mm	-
1.6	2	Support A	-	Production	Hardwood 26x12x163mm	-
1.7	2	Support B	-	Production	Hardwood 40x12x320mm	-
1.8	1	Botton rail	Botton rail.ipt	Production	Hardwood 50mm	8
1.9	1	Back plank	-	Production	Hardwood 576x12x285mm	-
1.10	2	Hinge A	-	Buy	Hinge stainless steel 100x40mm	-
1.11	1	Front Plank	Front Plank.ipt	Production	Hardwood 12mm	11
1.12	1	Door	-	Production	Steel C45 sheet gauge 18, 200x100mm	-
1.13	2	Hinge B	-	Buy	Hinge stainless steel 50x30mm	-
1.14	1	Knob	-	Buy	Kiln dried wood	-
1.15	1	Latch	-	Buy	Latch stainless steel 15mm	-
1.16	2	Frame A	-	Production	Hardwood 38x25x1228mm	-
1.17	2	Frame B	-	Production	Hardwood 38x25x524mm	-
1.18	2	Glass	-	Buy	Glass 1172x544x4mm	-
1.19	1	Plastic tray	-	Buy	Plastic tray	-
1.20	50	Joins A	-	Buy	Steel nail 2.5x55mm	-

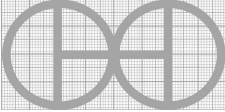
PROJECT		CREATED BY		APPROVED BY		DATE		VERSION	
Solar Wax Melter		J. Zeron		A. Morillo		10/08/2021		1.0	
PART NAME			FILE NAME					POS	
Parts list			uoc_swm_solar-wax-melter.csv					B1	
DEVELOPED BY			REDESIGNED BY		DOC. TYPE		MATERIAL		QUANTITY
University of California			 OHO e.V.		Parts list				
					LICENCE		SCALE		SHEET
					CC-BY-SA 4.0				3 /17

Parts list

POS	QTY	PART NAME	FILE NAME	PART TYPE	SPECIFICATIONS	SHEET
2.0	-	Internal pocket	Internal pocket.ipn	-	-	12
2.1	2	Botton insulator	-	Production	Celotex 872x576x12.7mm	-
2.2	4	Side insulator A	Side insulator A.ipt	Production	Celotex 12.7mm	13
2.3	4	Side insulator B	Side insulator B.ipt	Production	Celotex 12.7mm	14
2.4	4	Side insulator C	Side insulator C.ipt	Production	Celotex 12.7mm	15
2.5	1	Side insulator D	-	Production	Celotex 527x137x12.7mm	-
2.6	20	Joins B	-	Buy	Steel nail 1.6x30mm	-
3.0	-	Collector	Collector.ipn	-	-	16
3.1	1	Sheet pan A	-	Production	Steel C45 sheet gauge 18, 861x522mm	-
3.2	2	Sheet pan D	-	Production	Steel C45 sheet gauge 18, 861x100mm	-
3.3	1	Sheet pan C	-	Production	Steel C45 sheet gauge 18, 522x100mm	-
3.4	1	Sheet pan B	Sheet pan B	Production	Steel C45 sheet gauge 18	17

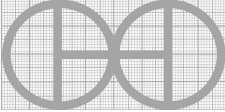
PROJECT		CREATED BY		APPROVED BY		DATE		VERSION	
Solar Wax Melter		J. Zeron		A. Morillo		10/08/2021		1.0	
PART NAME		FILE NAME						POS	
Parts list		uoc_swm_solar-wax-melter.csv						B1	
DEVELOPED BY		REDESIGNED BY		DOC. TYPE		MATERIAL		QUANTITY	
University of California		 OHO e.V.		Parts list					
				LICENCE		SCALE		SHEET	
				CC-BY-SA 4.0				4 /17	

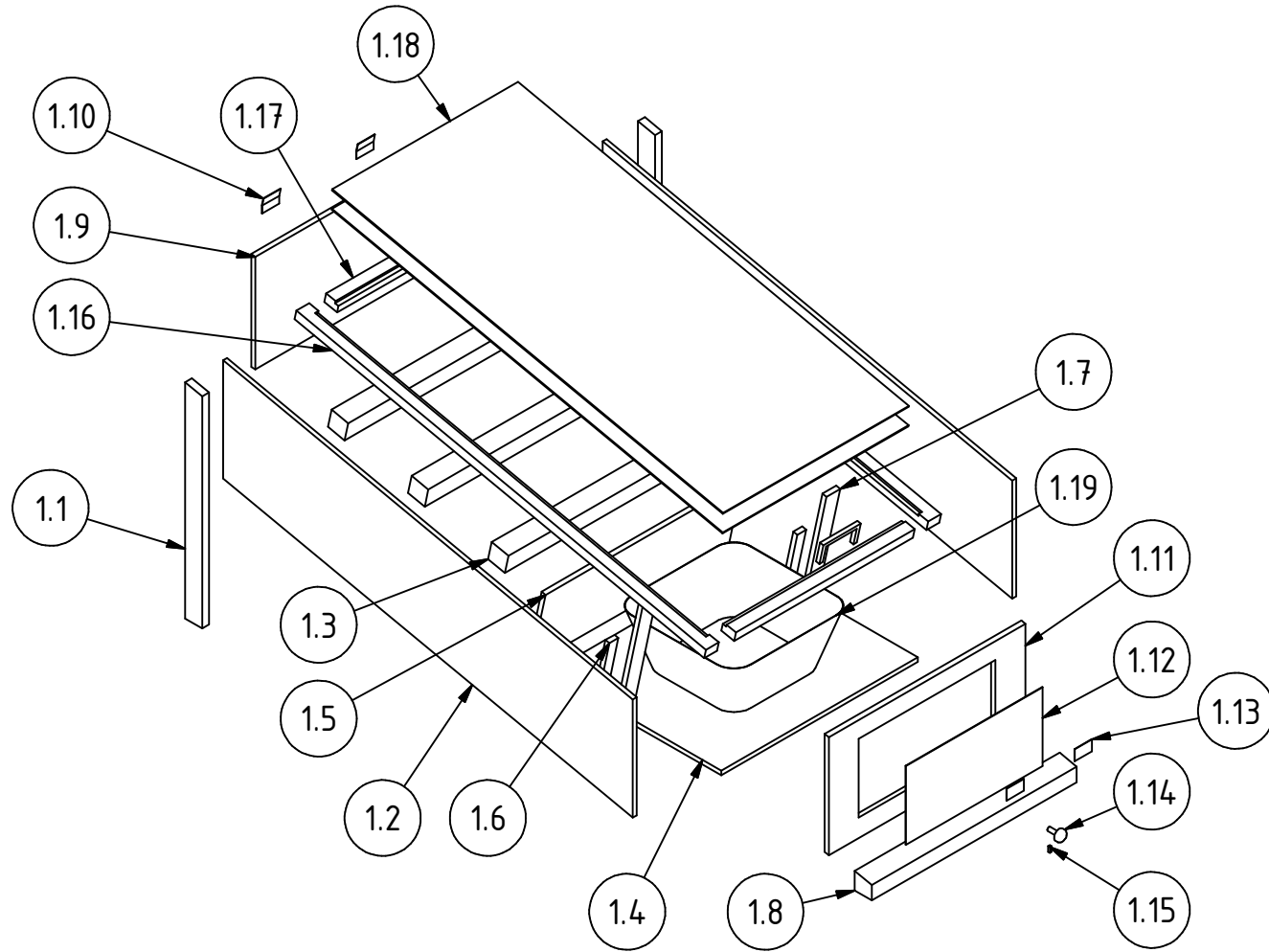

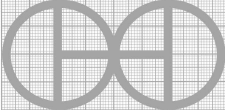
PROJECT	CREATED BY	APPROVED BY	DATE	VERSION
Solar Wax Melter	J. Zeron	A. Morillo	10/08/2021	1.0
PART NAME	FILE NAME			POS
External drawer	External drawer.ipn			1.0
DEVELOPED BY	REDESIGNED BY	DOC. TYPE	MATERIAL	QUANTITY
		Assembly		
University of California	OHO e.V.	LICENCE	SCALE	SHEET
		CC-BY-SA 4.0	1:15	5 /17

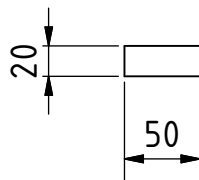
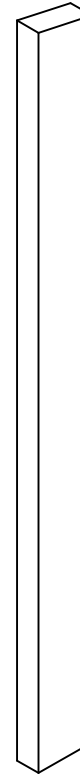
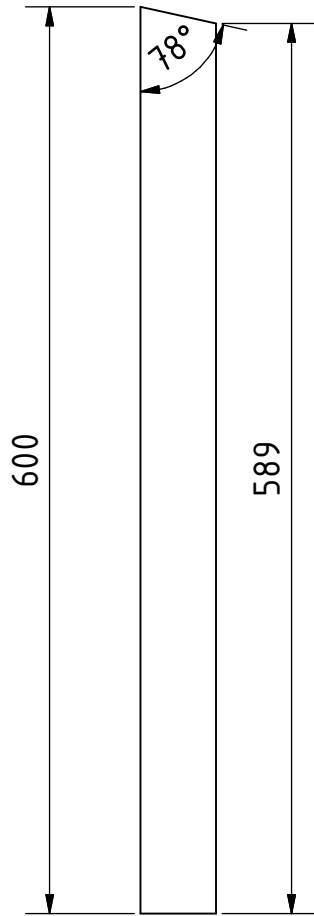

Note: All units in mm.

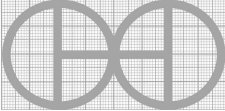
PROJECT	CREATED BY	APPROVED BY	DATE	VERSION
Solar Wax Melter	J. Zeron	A. Morillo	10/08/2021	1.0
PART NAME	FILE NAME			POS
Foot	Foot.ipt			1.1
DEVELOPED BY	REDESIGNED BY	DOC. TYPE	MATERIAL	QUANTITY
		Part	Hardwood	2
University of California	OHO e.V.	LICENCE	SCALE	SHEET
		CC-BY-SA 4.0	1:5	6 /17

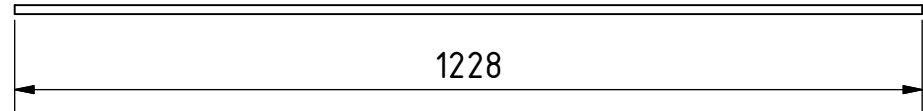
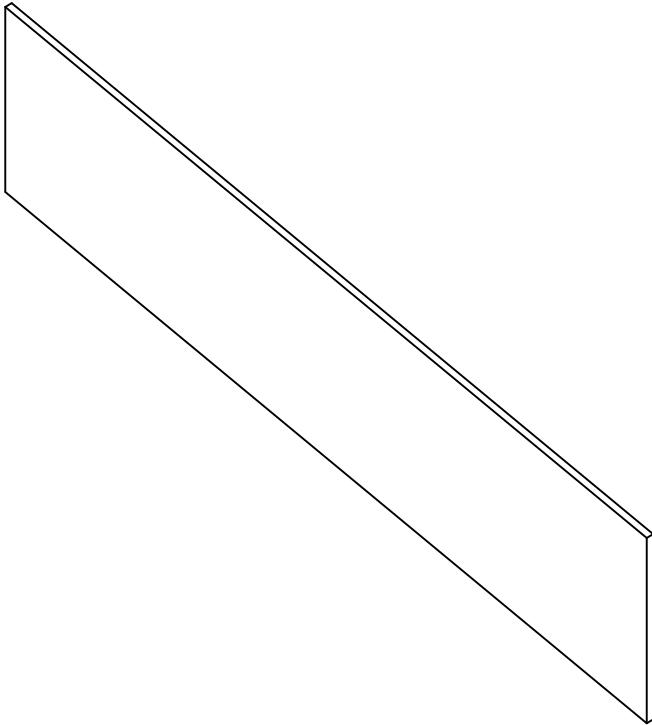
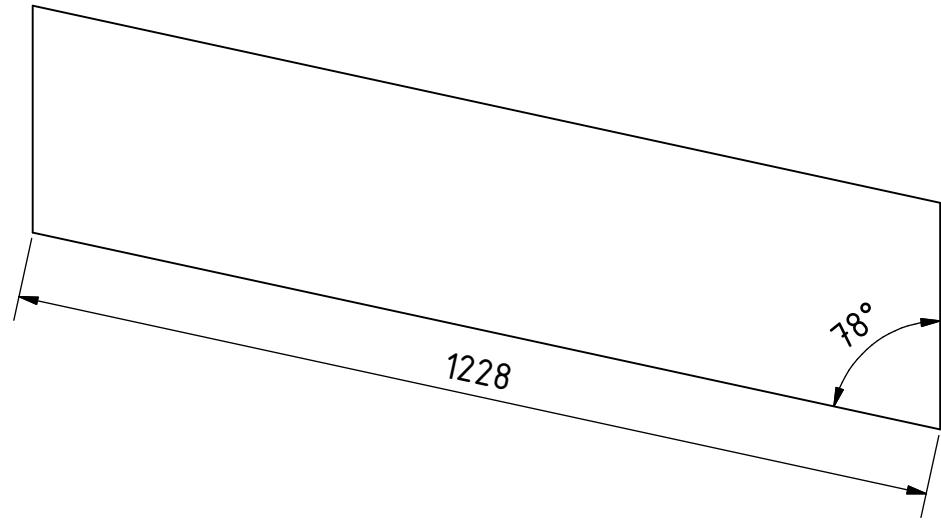
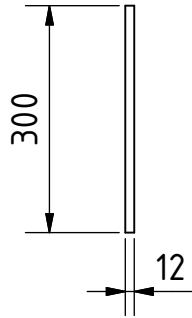

Note: All units in mm.

PROJECT	CREATED BY	APPROVED BY	DATE	VERSION
Solar Wax Melter	J. Zeron	A. Morillo	10/08/2021	1.0
PART NAME	FILE NAME			POS
Side plank	Side plank.ipt			1.2
DEVELOPED BY	REDESIGNED BY	DOC. TYPE	MATERIAL	QUANTITY
University of California	OHO e.V.	Part	Hardwood	2
		LICENCE	SCALE	SHEET
		CC-BY-SA 4.0	1:10	7 /17

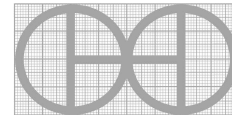

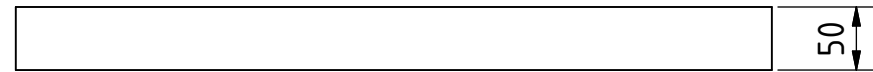
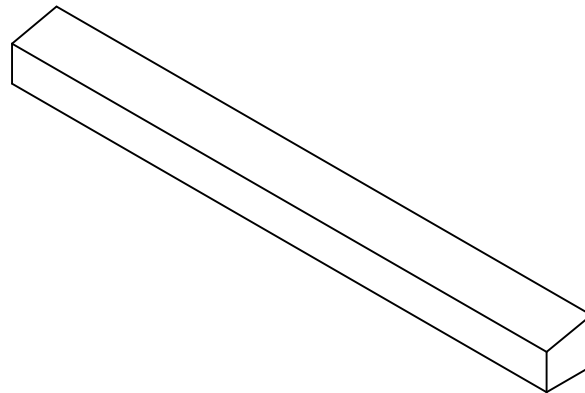
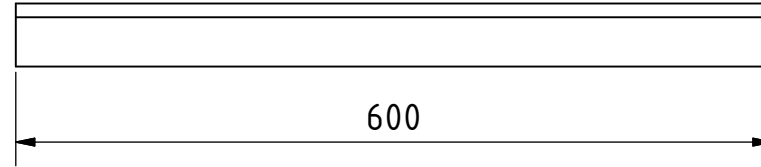
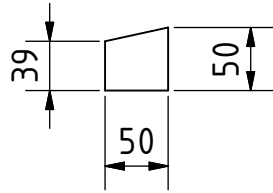

Note: All units in mm.

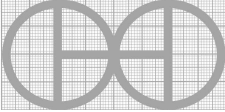
PROJECT	CREATED BY	APPROVED BY	DATE	VERSION
Solar Wax Melter	J. Zeron	A. Morillo	10/08/2021	1.0
PART NAME	FILE NAME			POS
Botton rail	Botton rail.ipt			1.8
DEVELOPED BY	REDESIGNED BY	DOC. TYPE	MATERIAL	QUANTITY
		Part	Hardwood	1
		LICENCE	SCALE	SHEET
University of California	OHO e.V.	CC-BY-SA 4.0	1:6	8 /17

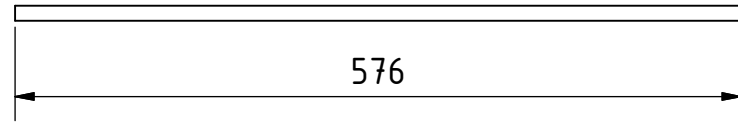
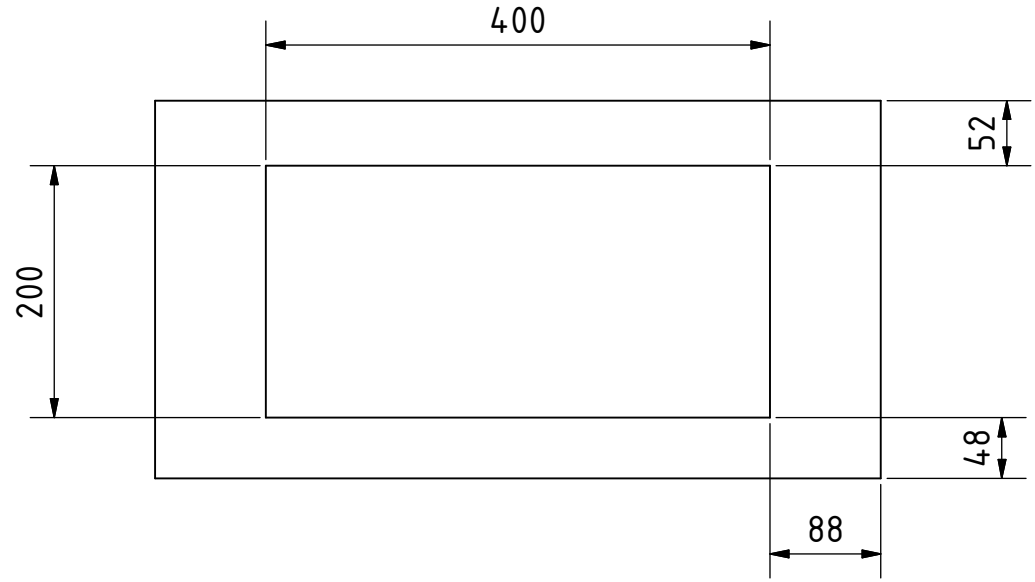
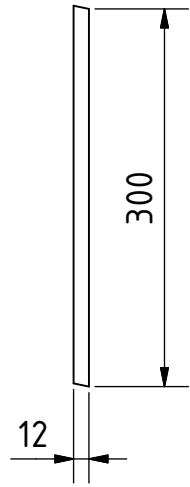
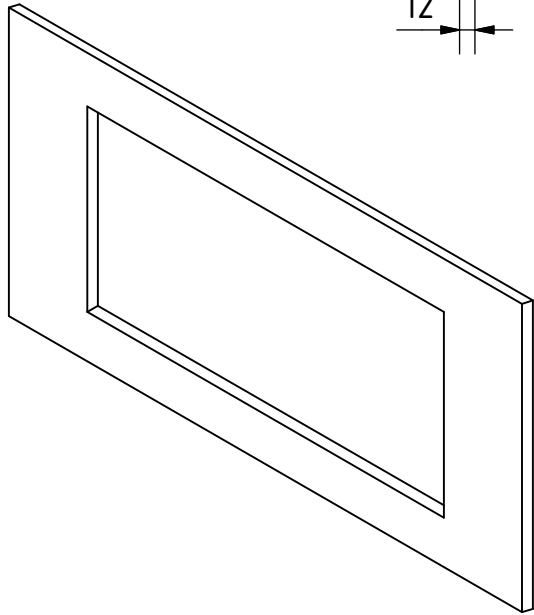

Note: All units in mm.

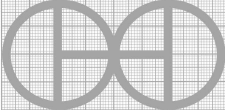
PROJECT	CREATED BY	APPROVED BY	DATE	VERSION
Solar Wax Melter	J. Zeron	A. Morillo	10/08/2021	1.0
PART NAME	FILE NAME			POS
Front Plank	Front Plank.ipt			1.11
DEVELOPED BY	REDESIGNED BY	DOC. TYPE	MATERIAL	QUANTITY
		Part	Hardwood	1
University of California	OHO e.V.	LICENCE	SCALE	SHEET
		CC-BY-SA 4.0	1:6	9 /17

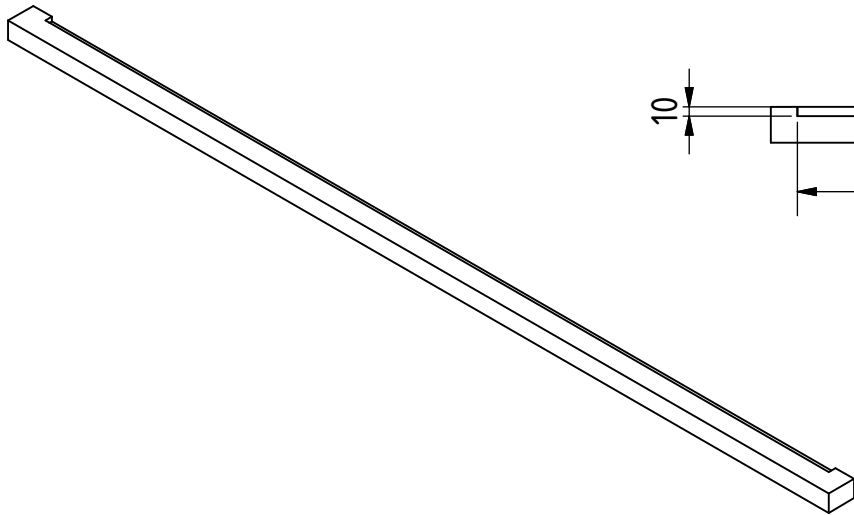
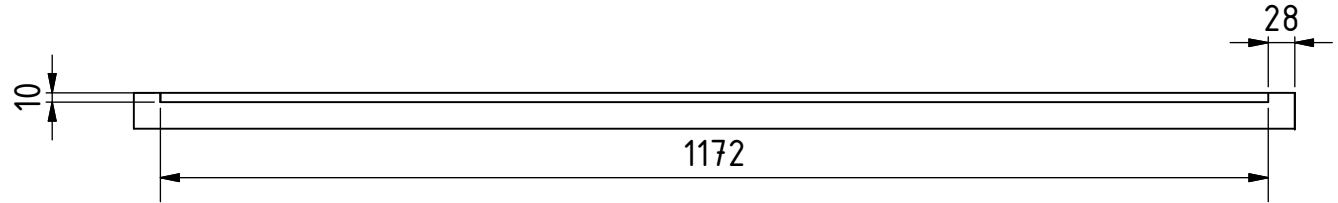
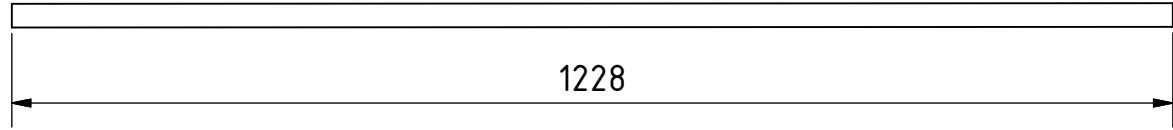
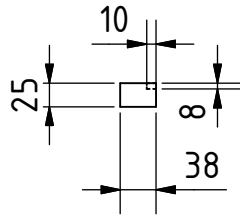

Note: All units in mm.

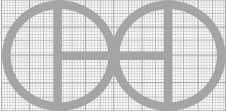
PROJECT	CREATED BY	APPROVED BY	DATE	VERSION
Solar Wax Melter	J. Zeron	A. Morillo	10/08/2021	1.0
PART NAME	FILE NAME			POS
Frame A	Frame A.ipt			1.16
DEVELOPED BY	REDESIGNED BY	DOC. TYPE	MATERIAL	QUANTITY
		Part	Hardwood	2
		LICENCE	SCALE	SHEET
University of California	OHO e.V.	CC-BY-SA 4.0	1:8	10 /17

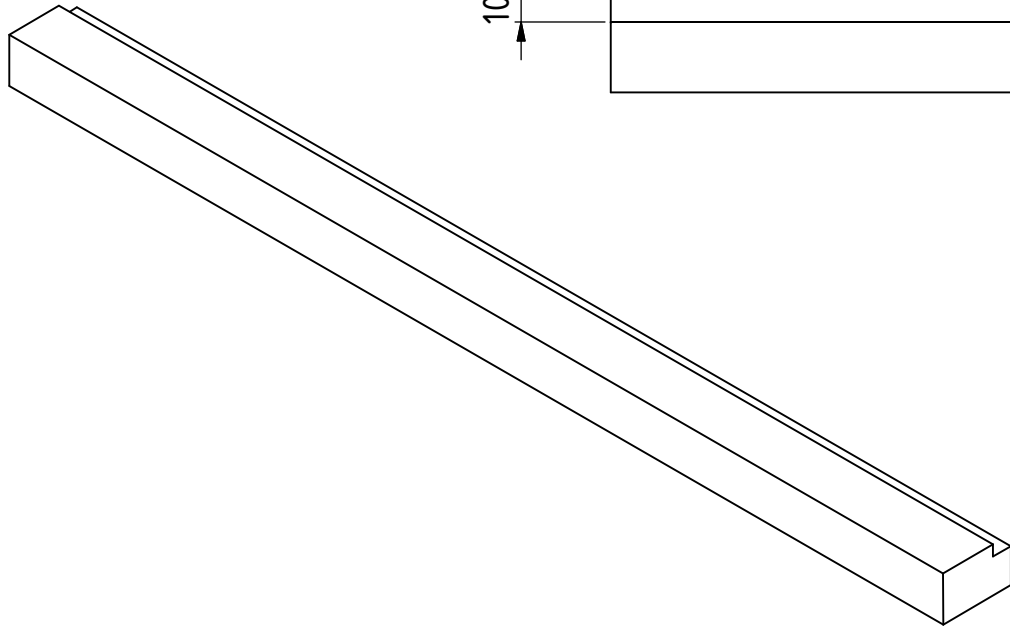
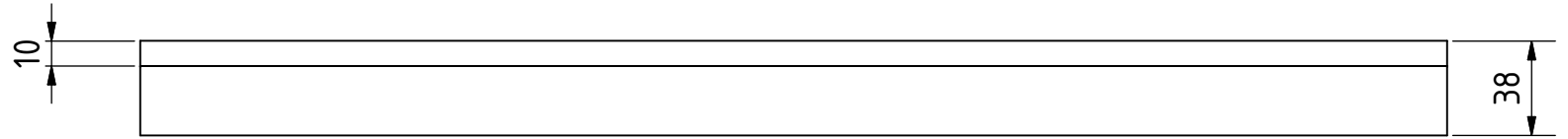
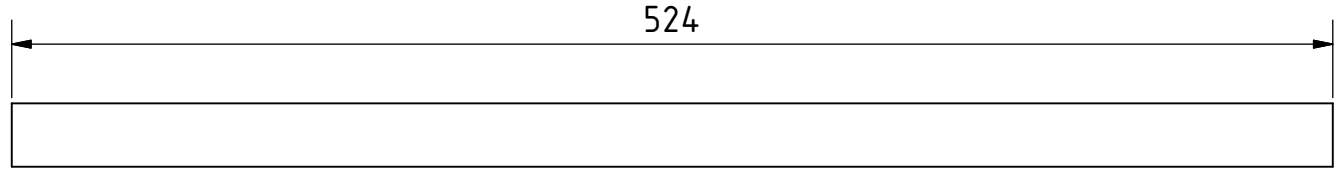
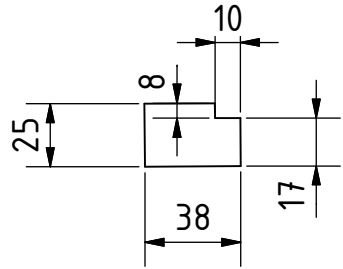

Note: All units in mm.

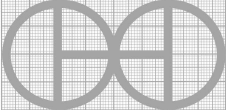
PROJECT	CREATED BY	APPROVED BY	DATE	VERSION
Solar Wax Melter	J. Zeron	A. Morillo	10/08/2021	1.0
PART NAME	FILE NAME			POS
Frame B	Frame B.ipt			1.17
DEVELOPED BY	REDESIGNED BY	DOC. TYPE	MATERIAL	QUANTITY
		Part	Hardwood	2
		LICENCE	SCALE	SHEET
University of California	OHO e.V.	CC-BY-SA 4.0	1:3	11 /17

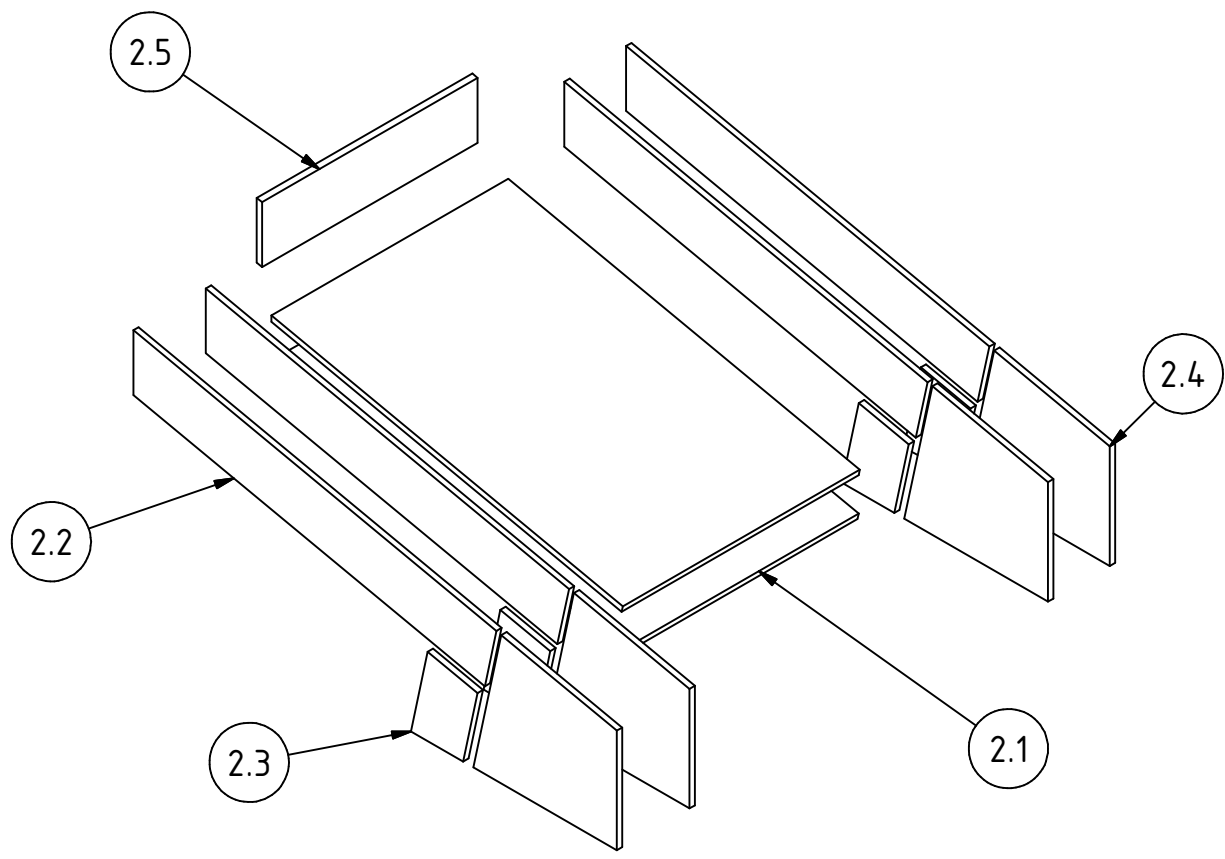

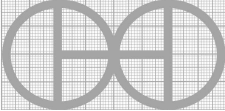
PROJECT	CREATED BY	APPROVED BY	DATE	VERSION
Solar Wax Melter	J. Zeron	A. Morillo	10/08/2021	1.0
PART NAME	FILE NAME			POS
Internal pocket	Internal pocket.ipn			2.0
DEVELOPED BY	REDESIGNED BY	DOC. TYPE	MATERIAL	QUANTITY
		Assembly		
University of California	OHO e.V.	LICENCE	SCALE	SHEET
		CC-BY-SA 4.0	1:13	12 /17

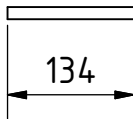
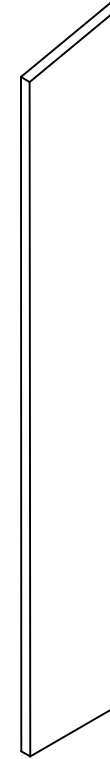
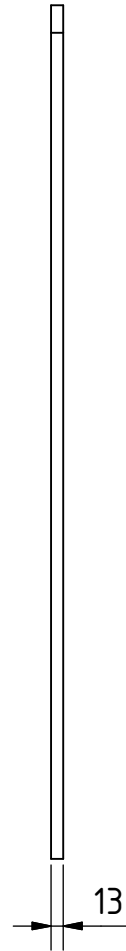
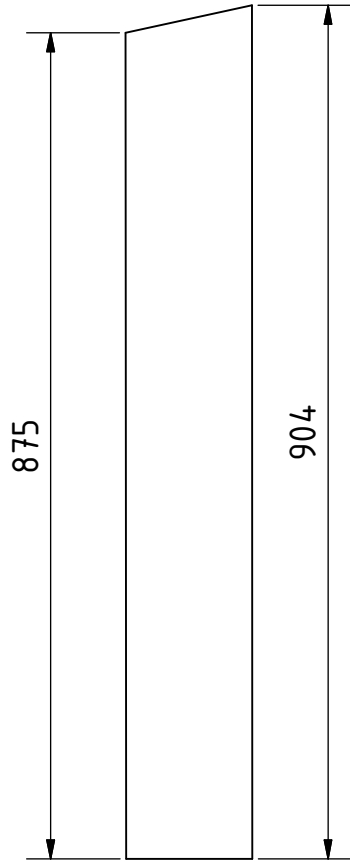

Note: All units in mm.

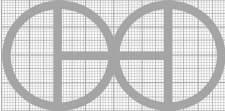
PROJECT	CREATED BY	APPROVED BY	DATE	VERSION
Solar Wax Melter	J. Zeron	A. Morillo	10/08/2021	1.0
PART NAME	FILE NAME			POS
Side insulator A	Side insulator A.ipt			2.2
DEVELOPED BY	REDESIGNED BY	DOC. TYPE	MATERIAL	QUANTITY
		Part	Celotex	4
University of California	OHO e.V.	LICENCE	SCALE	SHEET
		CC-BY-SA 4.0	1:8	13 /17

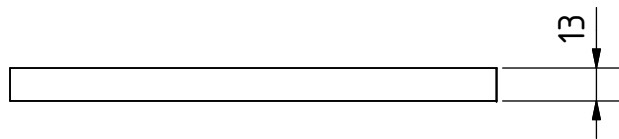
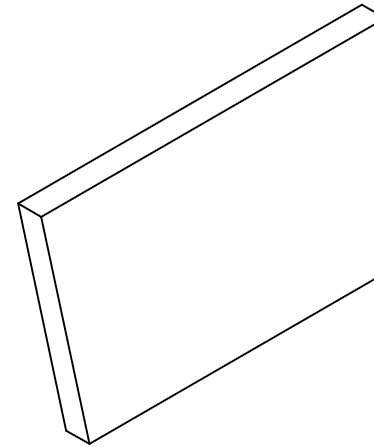
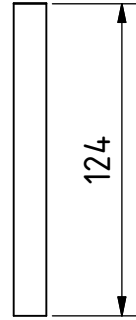
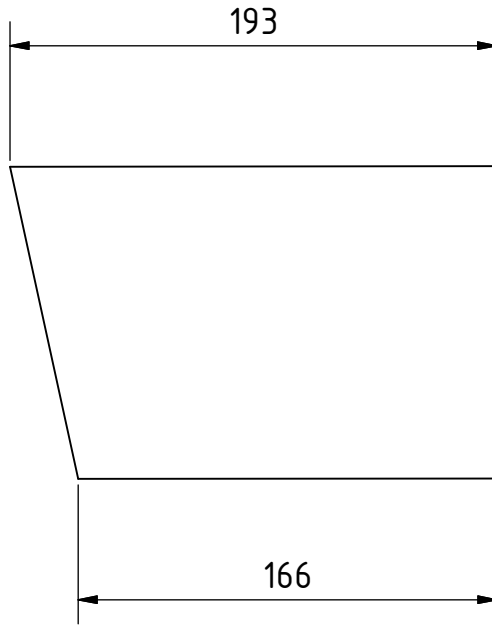

Note: All units in mm.

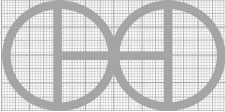
PROJECT	CREATED BY	APPROVED BY	DATE	VERSION
Solar Wax Melter	J. Zeron	A. Morillo	10/08/2021	1.0
PART NAME	FILE NAME			POS
Side insulator B	Side insulator B.ipt			2.3
DEVELOPED BY	REDESIGNED BY	DOC. TYPE	MATERIAL	QUANTITY
		Part	Celotex	4
University of California	OHO e.V.	LICENCE	SCALE	SHEET
		CC-BY-SA 4.0	1:3	14 /17

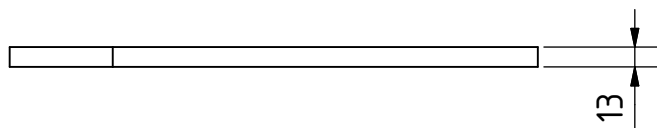
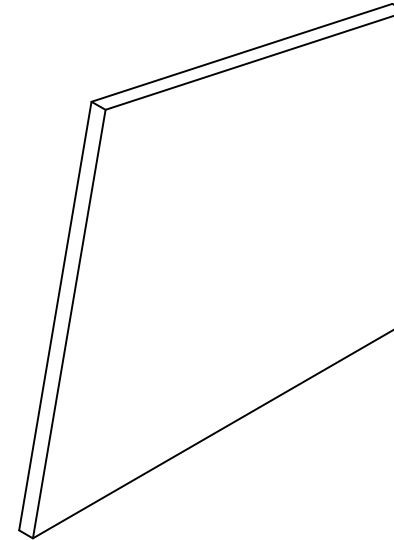
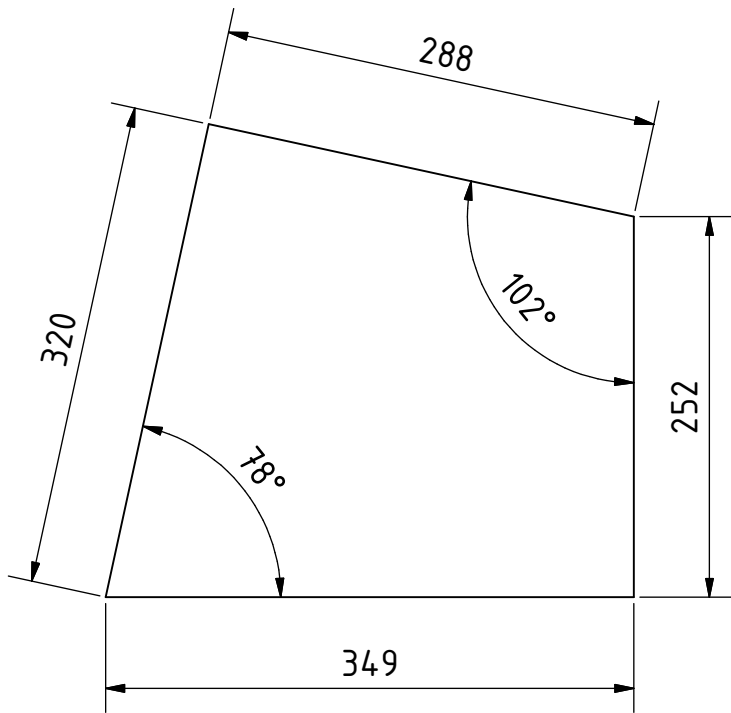

Note: All units in mm.

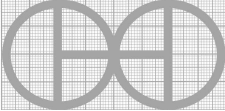
PROJECT	CREATED BY	APPROVED BY	DATE	VERSION
Solar Wax Melter	J. Zeron	A. Morillo	10/08/2021	1.0
PART NAME	FILE NAME			POS
Side insulator C	Side insulator C.ipt			2.4
DEVELOPED BY	REDESIGNED BY	DOC. TYPE	MATERIAL	QUANTITY
		Part	Celotex	4
University of California	OHO e.V.	LICENCE	SCALE	SHEET
		CC-BY-SA 4.0	1:5	15 /17

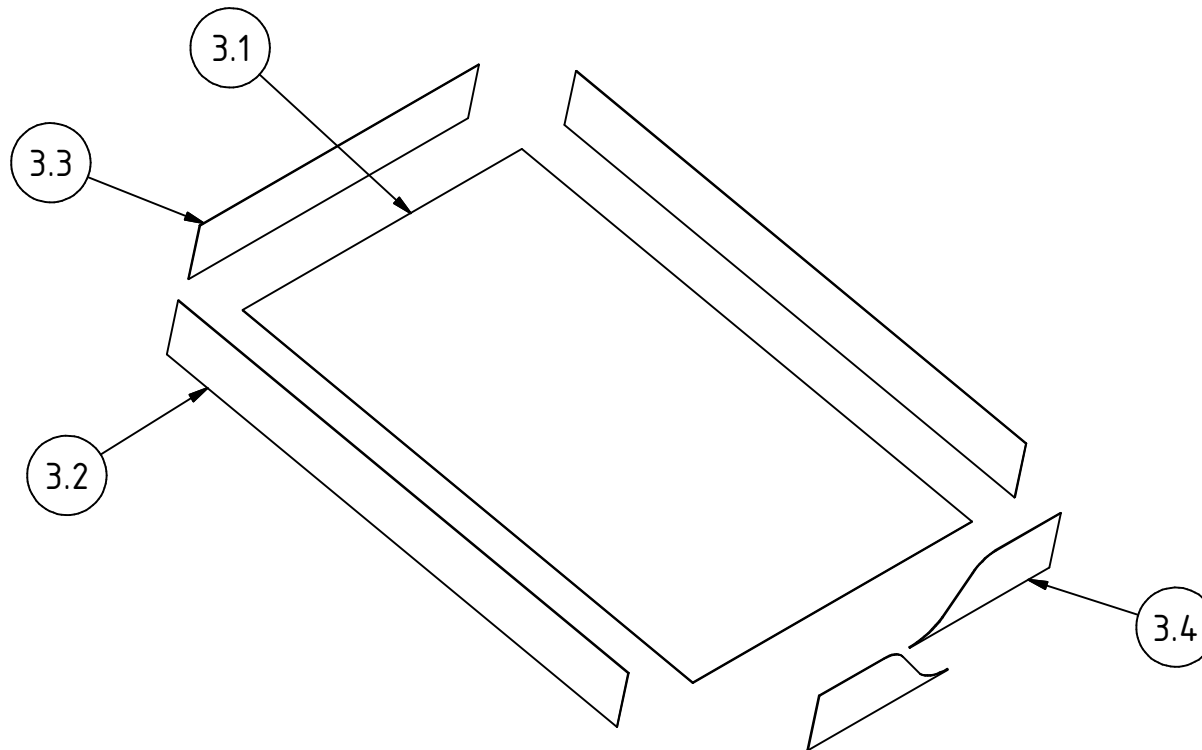

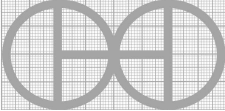
PROJECT	CREATED BY	APPROVED BY	DATE	VERSION
Solar Wax Melter	J. Zeron	A. Morillo	10/08/2021	1.0
PART NAME	FILE NAME			POS
Collector	Collector.ipn			3.0
DEVELOPED BY	REDESIGNED BY	DOC. TYPE	MATERIAL	QUANTITY
University of California	 OHO e.V.	Assembly		
		LICENCE	SCALE	SHEET
		CC-BY-SA 4.0	1:10	16 /17

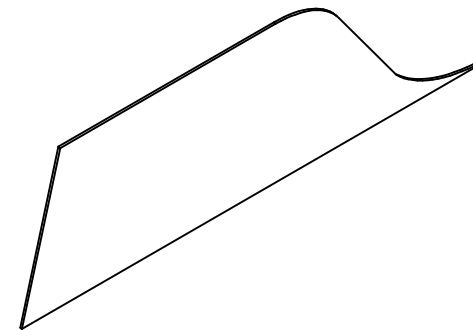
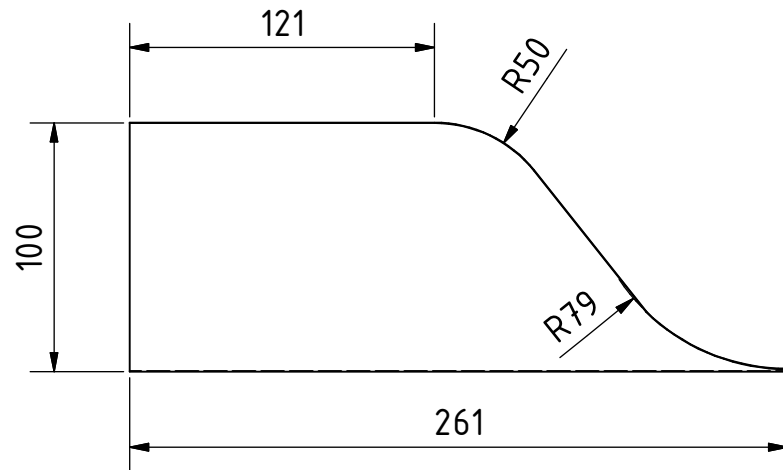

Note: All units in mm.

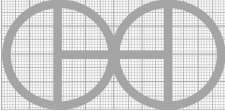
PROJECT	CREATED BY	APPROVED BY	DATE	VERSION
Solar Wax Melter	J. Zeron	A. Morillo	10/08/2021	1.0
PART NAME	FILE NAME			POS
Sheet pan D	Sheet pan D.ipt			3.4
DEVELOPED BY	REDESIGNED BY	DOC. TYPE	MATERIAL	QUANTITY
University of California	 OHO e.V.	Part	Steel C45	2
		LICENCE	SCALE	SHEET
		CC-BY-SA 4.0	1:3	17 /17