

Note: All units are in mm

PROJECT		CREATED BY	APPROVED BY	DATE	VERSION
HANDCART		J. ROSCIANO	A. MORILLO	31/05/2021	1.1
PART NAME		FILE NAME			PART CODE
3D Views		Handcart.iam			A1
DEVELOPED BY	REDESIGNED BY	SUPPORTED BY	DOC. TYPE	MATERIAL	QUANTITY
Unknown	OHO e.V.		ASSEMBLY		1
			LICENCE	SCALE	SHEET
			CC-BY-SA 4.0	1/20	1 /17

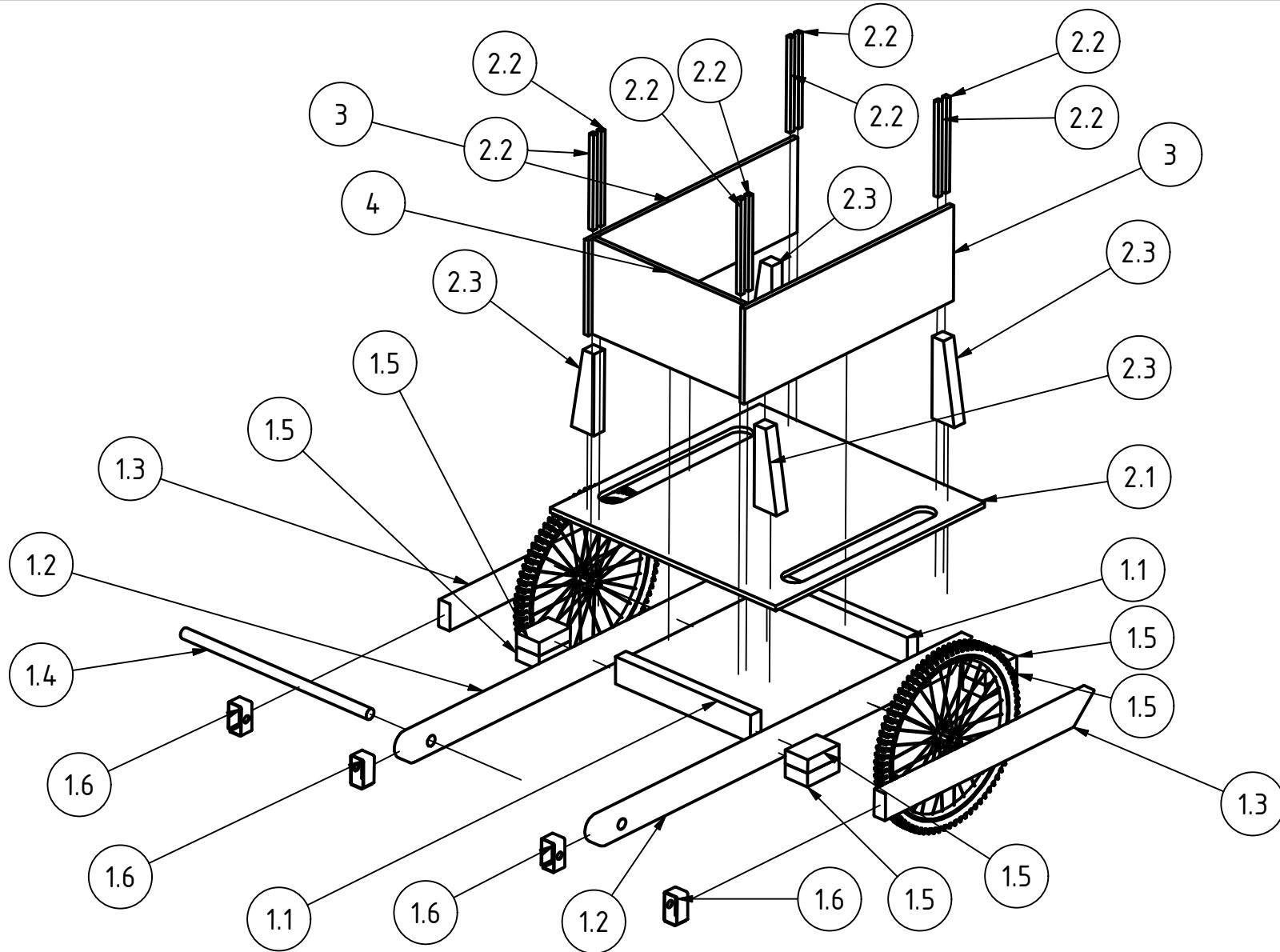

PROJECT		CREATED BY	APPROVED BY	DATE	VERSION
HANDCART		J. ROSCIANO	A. MORILLO	31/05/2021	1.1
PART NAME		FILE NAME			PART CODE
Exploded 3D view		Handcart.ipt			A2
DEVELOPED BY	REDESIGNED BY	SUPPORTED BY	DOC. TYPE	MATERIAL	QUANTITY
Unknown	OHO e.V.		ASSEMBLY		1
			LICENCE	SCALE	SHEET
			CC-BY-SA 4.0	1/20	2 / 17

PART LIST

POS	POS.OLD	QTY	PART NAME	FILE NAME	PART TYPE	SPECIFICATIONS	SHEET
A1		1	Handcart		ASSEMBLY		1
A2		1	Handcart		ASSEMBLY		2
B1		1	PART LIST		ASSEMBLY		3
C1			TECH NOTES		ASSEMBLY		4
1.0		1	Base Frame	Base Frame.iam	ASSEMBLY		5
1.1		2	Cross Piece	Cross Piece.ipt	Production	29"x2"x4" pinewood	6
1.2		2	Interior Frame	Interior Frame.ipt	Production	72"x2"x4" pinewood	7
1.3		2	Outriggers	Outriggers.ipt	Production	40"x2"x4" wood	8
1.4		1	Handle	Handle.ipt	Production	1/2" diameter pinewood pole 33" long	9
1.5		8	Spacer Blocks	Spacer Blocks.ipt	Production	6"x2"x4" pinewood	10
1.6		4	Axle Supports	Axle Supports.ipt	Production	5"x2"x4" galvanized corner brackets	11
2.0		1	Plywood floor	Plywood floor.iam	ASSEMBLY		12
2.1		1	Floor	Floor.ipt	Production	40"x40"x3/4" plywood	13
2.2		8	Cleats	Cleats.ipt	Production	3/4"x3/4"x14" pinewood	14
2.3		4	Braces	Braces.ipt	Production	17"x2"x4" pinewood	15
3.0		2	Side Panel Wall	Side Panel Wall.ipt	Production	14"x40"x3/4" plywood	16
4.0		1	Rear Panel	Rear Panel.ipt	Production	14"x38 1/4"x3/4" plywood	17
5.0		2	Wheels	Wheels.ipt	Buy	Bicycle wheels 26	
6.0		60	Screw 2 1/2	Screw 2 1/2.ipt	Standard	2 1/2" galvanized deck screws	
7.0		8	Screw 1 1/4	Screw 1 1/4.ipt	Standard	1 1/4" galvanized deck screws	

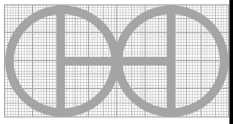
PROJECT		CREATED BY	APPROVED BY	DATE	VERSION
HANDCART		J. ROSCIANO	A. MORILLO	31/05/2021	1.1
PART NAME		FILE NAME			PART CODE
PART LIST		u_wh_wooden-handcart.csv			B1
DEVELOPED BY	REDESIGNED BY	SUPPORTED BY	DOC. TYPE	MATERIAL	QUANTITY
Unknown	 OH0 e.V.		PART LIST		
			LICENCE	SCALE	SHEET
			CC-BY-SA 4.0		3 /17

TECHNICAL NOTES

NOTES	CONTENT
GENERAL NOTES	
Metal structure treatment	Use a hammer to bend 5" metal corner bracket around each 2x4. Bore a hole in each bracket, large enough to accept the end of the axle

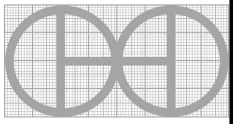
PROJECT		CREATED BY	APPROVED BY	DATE	VERSION
HANDCART		J. ROSCIANO	A. MORILLO	31/05/2021	1.1
PART NAME		FILE NAME			PART CODE
TECH NOTES					C1
DEVELOPED BY	REDESIGNED BY	SUPPORTED BY	DOC. TYPE	MATERIAL	QUANTITY
			TECH NOTES		
Unknown	OHO e.V.		LICENCE	SCALE	SHEET
			CC-BY-SA 4.0		4 /17

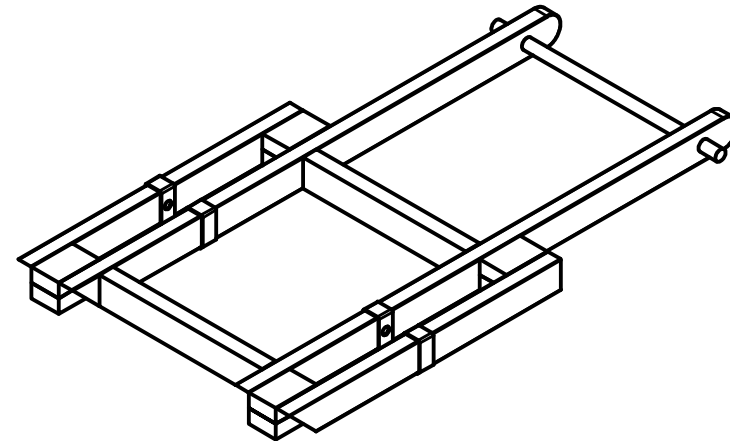
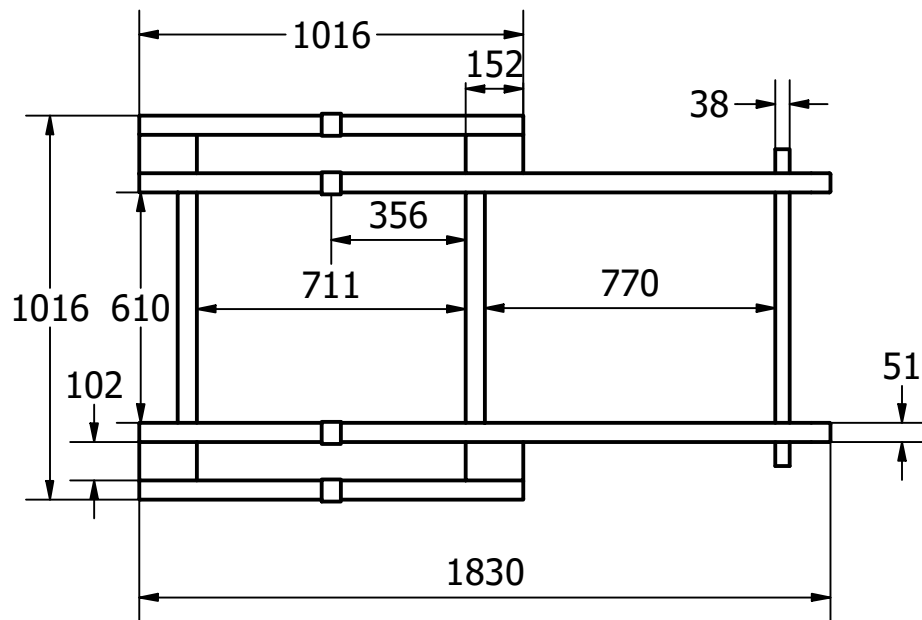
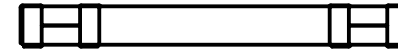
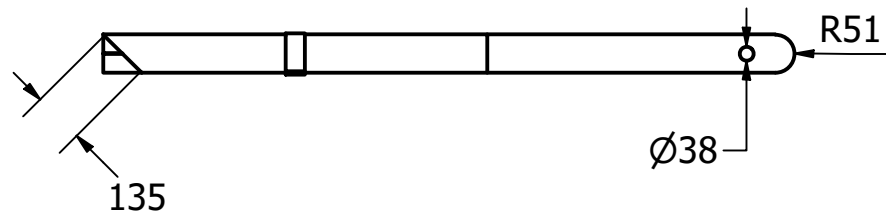

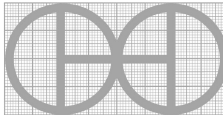
PROJECT		CREATED BY	APPROVED BY	DATE	VERSION
HANDCART		J. ROSCIANO	A. MORILLO	31/05/2021	1.1
PART NAME		FILE NAME			PART CODE
Base Frame		Base Frame.iam			1.0
DEVELOPED BY	REDESIGNED BY	SUPPORTED BY	DOC. TYPE	MATERIAL	QUANTITY
			ASSEMBLY		1
Unknown	OHO e.V.		LICENCE	SCALE	SHEET
			CC-BY-SA 4.0	1/20	5 /17

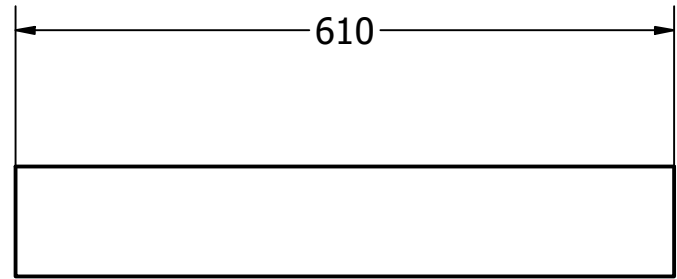
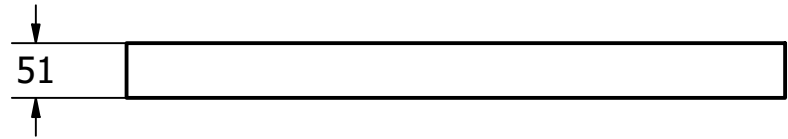
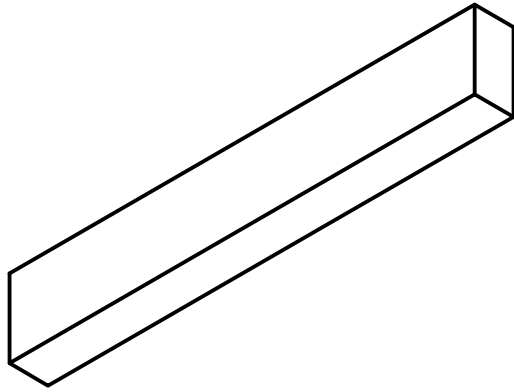

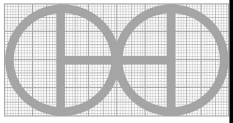
PROJECT		CREATED BY	APPROVED BY	DATE	VERSION
HANDCART		J. ROSCIANO	A. MORILLO	31/05/2021	1.1
PART NAME		FILE NAME			PART CODE
Cross Piece		Cross Piece.ipt			1.1
DEVELOPED BY	REDESIGNED BY	SUPPORTED BY	DOC. TYPE	MATERIAL	QUANTITY
			PART	KILN DRIED PINE	2
			LICENCE	SCALE	SHEET
Unknown	OHO e.V.		CC-BY-SA 4.0	1/7	6 /17

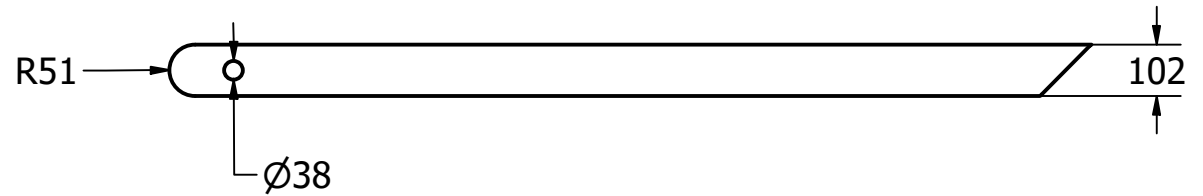
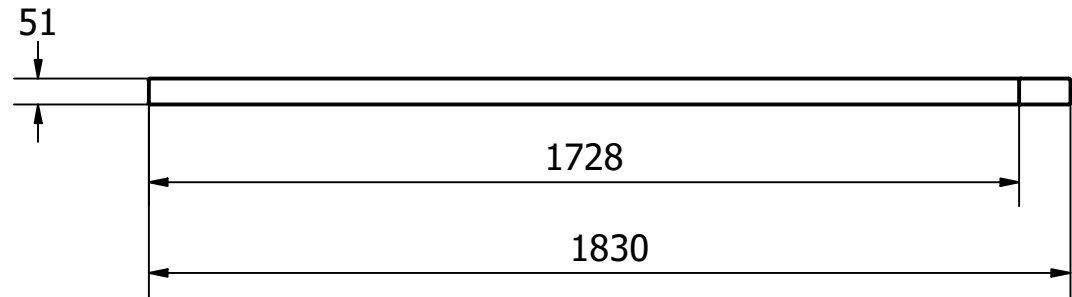
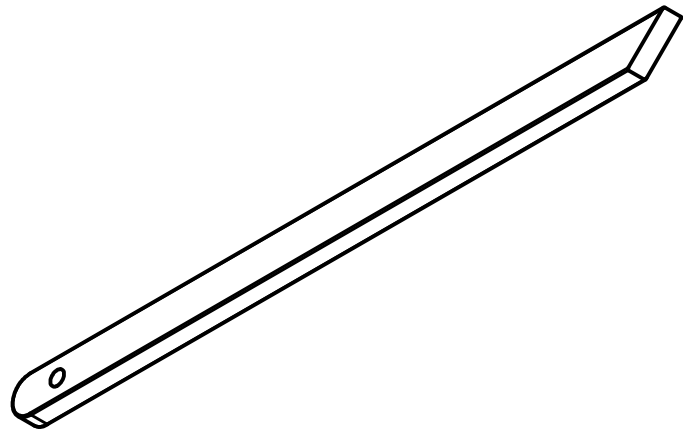

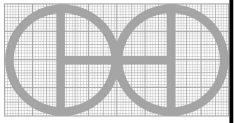
PROJECT		CREATED BY	APPROVED BY	DATE	VERSION
HANDCART		J. ROSCIANO	A. MORILLO	31/05/2021	1.1
PART NAME		FILE NAME			PART CODE
Interior Frame		Interior Frame.ipt			1.2
DEVELOPED BY	REDESIGNED BY	SUPPORTED BY	DOC. TYPE	MATERIAL	QUANTITY
			PART	KILN DRIED PINE	2
Unknown	OHO e.V.		LICENCE	SCALE	SHEET
			CC-BY-SA 4.0	1/15	7 /17

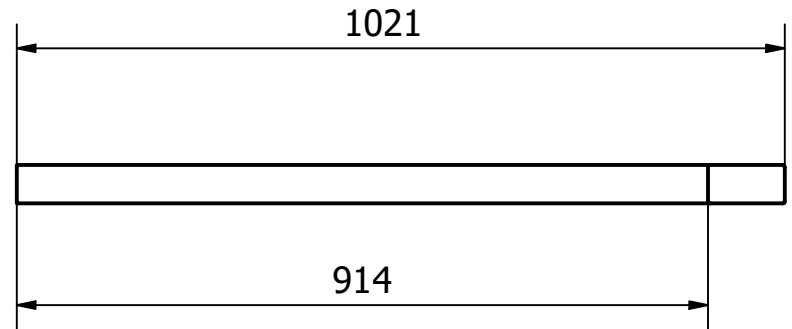
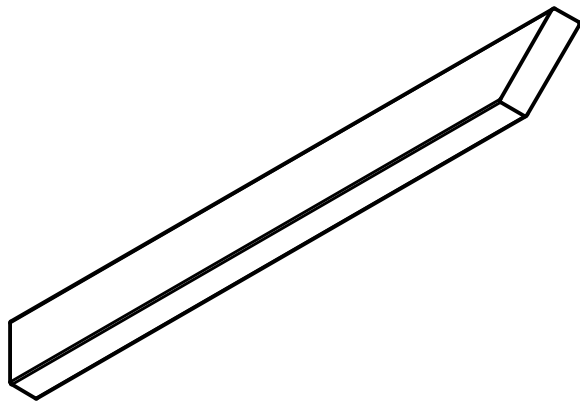

A-A

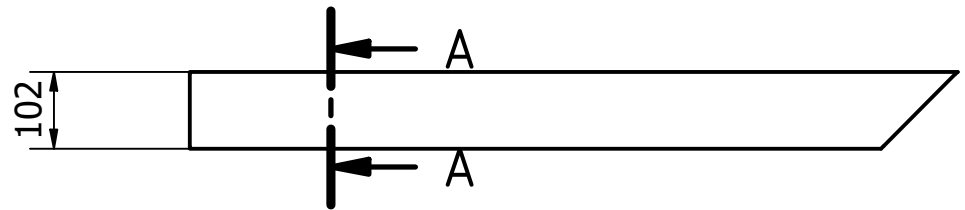
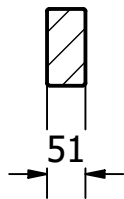

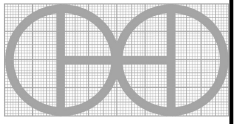
PROJECT		CREATED BY	APPROVED BY	DATE	VERSION
HANDCART		J. ROSCIANO	A. MORILLO	31/05/2021	1.1
PART NAME		FILE NAME			PART CODE
Outriggers		Outriggers.ipt			1.3
DEVELOPED BY	REDESIGNED BY	SUPPORTED BY	DOC. TYPE	MATERIAL	QUANTITY
Unknown	 OHO e.V.		PART	KILN DRIED PINE	2
			LICENCE	SCALE	SHEET
			CC-BY-SA 4.0	1/10	8 /17

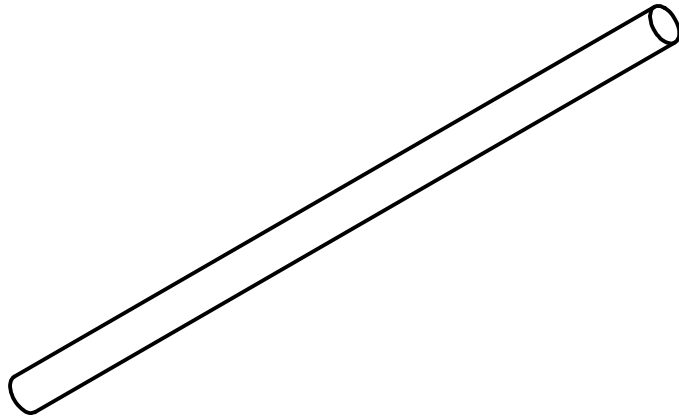

→ ○ ← Ø38

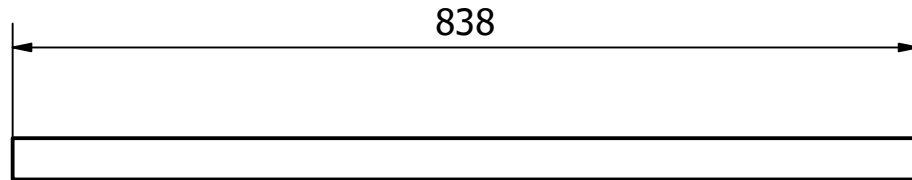

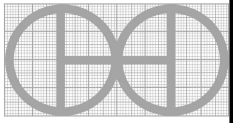
PROJECT		CREATED BY	APPROVED BY	DATE	VERSION
HANDCART		J. ROSCIANO	A. MORILLO	31/05/2021	1.1
PART NAME		FILE NAME			PART CODE
Handle		Handle.ipt			1.4
DEVELOPED BY	REDESIGNED BY	SUPPORTED BY	DOC. TYPE	MATERIAL	QUANTITY
			PART	KILN DRIED PINE	1
Unknown	OHO e.V.		LICENCE	SCALE	SHEET
			CC-BY-SA 4.0	1/7	9 /17

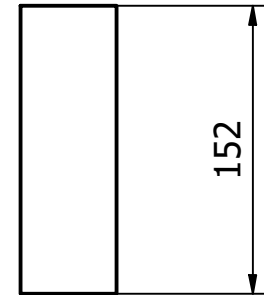
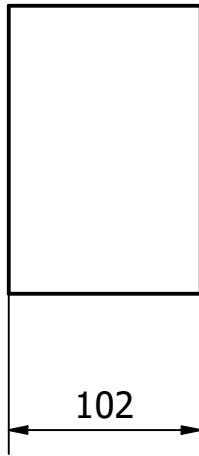
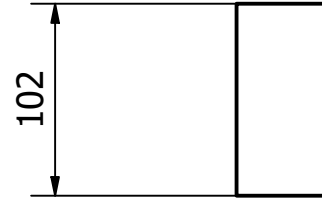
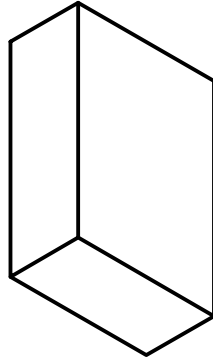

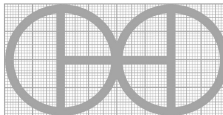
PROJECT		CREATED BY	APPROVED BY	DATE	VERSION
HANDCART		J. ROSCIANO	A. MORILLO	31/05/2021	1.1
PART NAME		FILE NAME			PART CODE
Spacer Blocks		Spacer Blocks.ipt			1.5
DEVELOPED BY	REDESIGNED BY	SUPPORTED BY	DOC. TYPE	MATERIAL	QUANTITY
			PART	KILN DRIED PINE	8
Unknown	OHO e.V.		LICENCE	SCALE	SHEET
			CC-BY-SA 4.0	1/4	10 /17

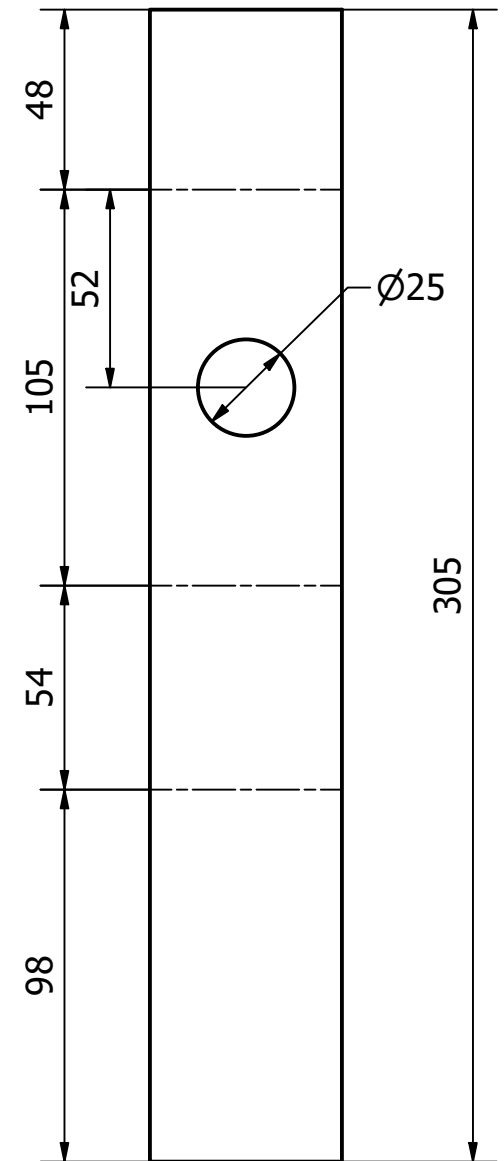
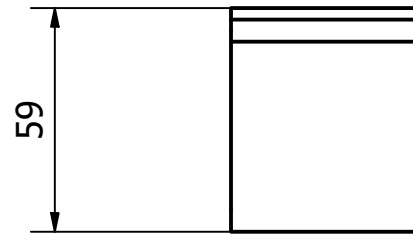
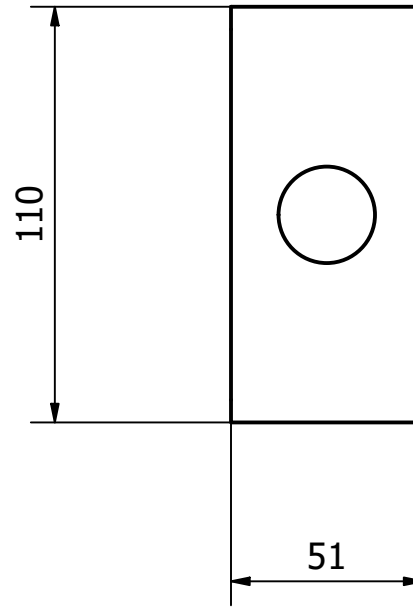
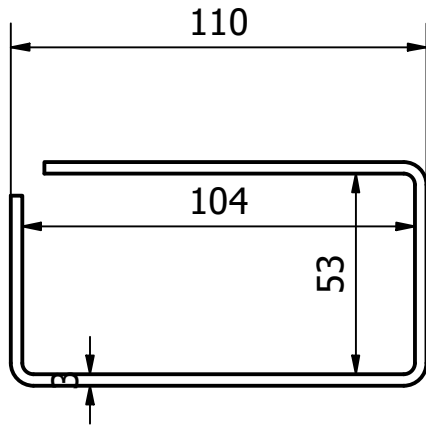
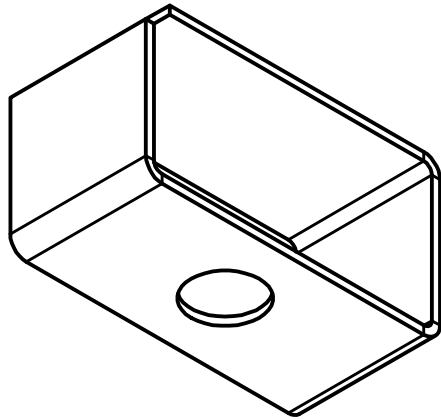

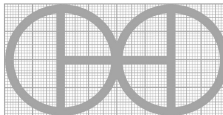
PROJECT		CREATED BY		APPROVED BY		DATE		VERSION	
HANDCART		J. ROSCIANO		A. MORILLO		31/05/2021		1.1	
PART NAME				FILE NAME				PART CODE	
Axle Supports				Axle Supports.ipt				1.6	
DEVELOPED BY		REDESIGNED BY		SUPPORTED BY		DOC. TYPE	MATERIAL		QUANTITY
Unknown		 OHO e.V.				PART	GALVANIZED		4
						LICENCE	SCALE		SHEET
						CC-BY-SA 4.0	1/2		11 /17

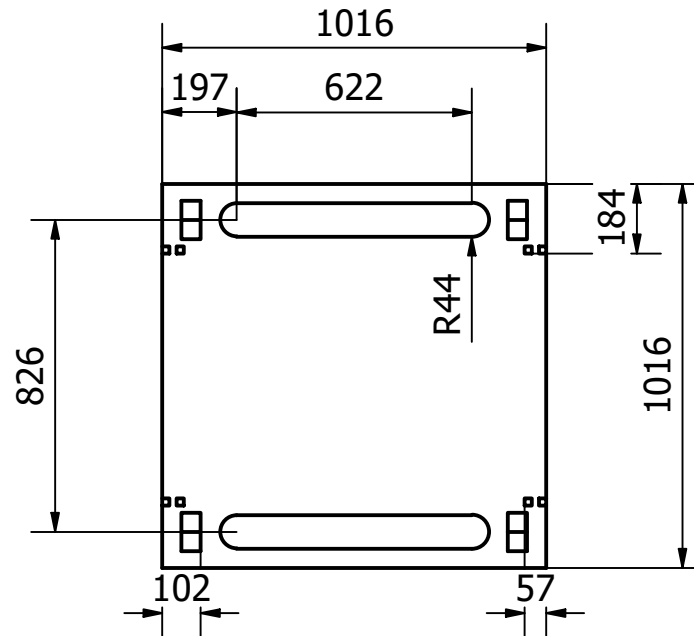
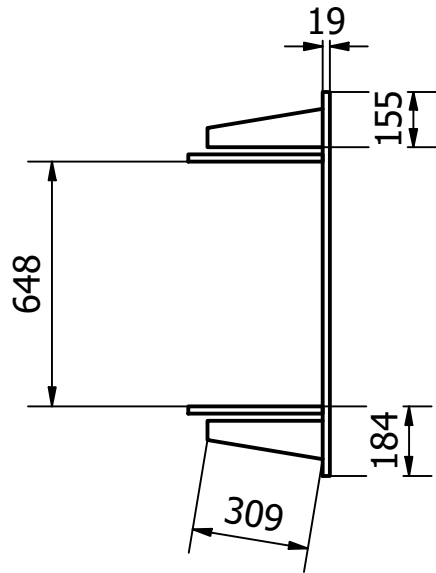
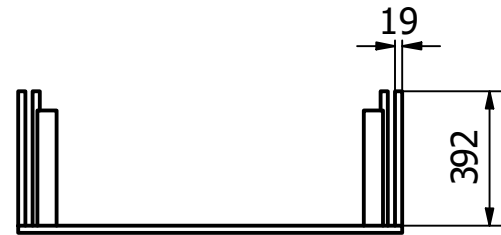
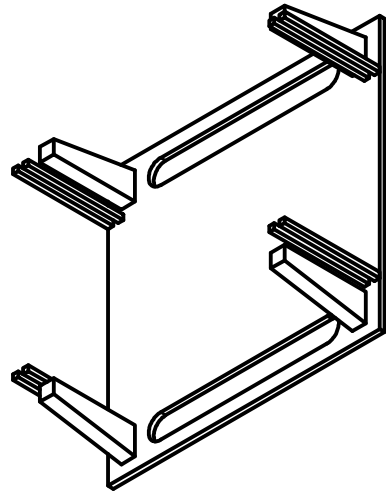

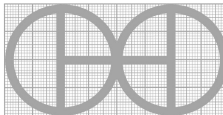
PROJECT		CREATED BY	APPROVED BY	DATE	VERSION
HANDCART		J. ROSCIANO	A. MORILLO	31/05/2021	1.1
PART NAME		FILE NAME			PART CODE
Plywood floor		Plywood floor.iam			2.0
DEVELOPED BY	REDESIGNED BY	SUPPORTED BY	DOC. TYPE	MATERIAL	QUANTITY
			ASSEMBLY		1
			LICENCE	SCALE	SHEET
Unknown	OHO e.V.		CC-BY-SA 4.0	1/20	12 /17

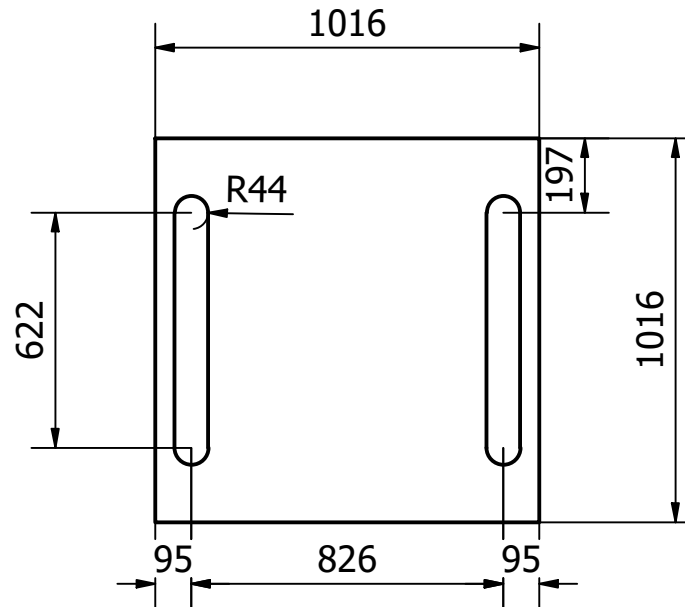
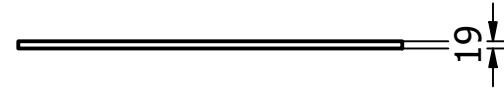
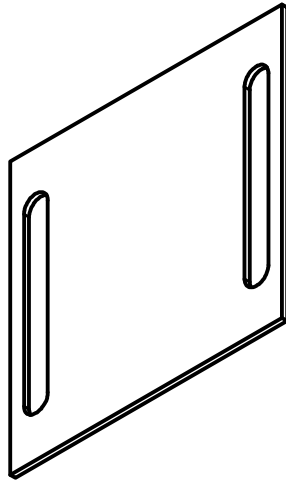

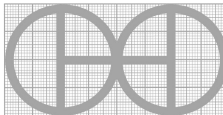
PROJECT		CREATED BY	APPROVED BY	DATE	VERSION
HANDCART		J. ROSCIANO	A. MORILLO	31/05/2021	1.1
PART NAME		FILE NAME			PART CODE
Floor		Floor.ipt			2.1
DEVELOPED BY	REDESIGNED BY	SUPPORTED BY	DOC. TYPE	MATERIAL	QUANTITY
			PART	KILN DRIED PINE	1
			LICENCE	SCALE	SHEET
Unknown	OHO e.V.		CC-BY-SA 4.0	1/20	13 /17

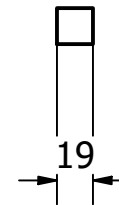
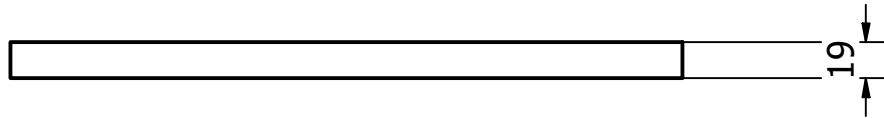
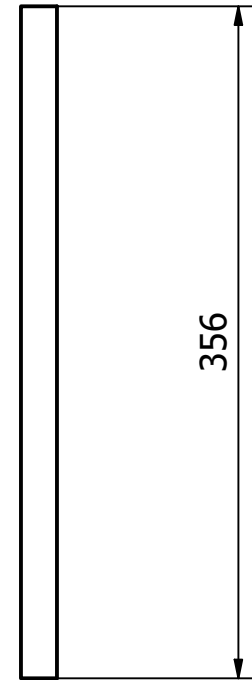
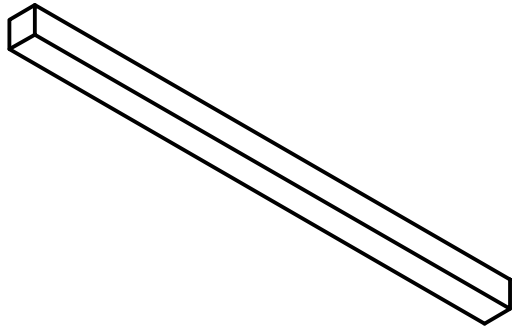

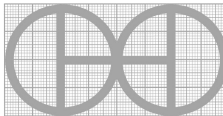
PROJECT		CREATED BY	APPROVED BY	DATE	VERSION
HANDCART		J. ROSCIANO	A. MORILLO	31/05/2021	1.1
PART NAME		FILE NAME			PART CODE
Cleats		Cleats.ipt			2.2
DEVELOPED BY	REDESIGNED BY	SUPPORTED BY	DOC. TYPE	MATERIAL	QUANTITY
			PART	KILN DRIED PINE	8
Unknown	OHO e.V.		LICENCE	SCALE	SHEET
			CC-BY-SA 4.0	1/4	14 /17

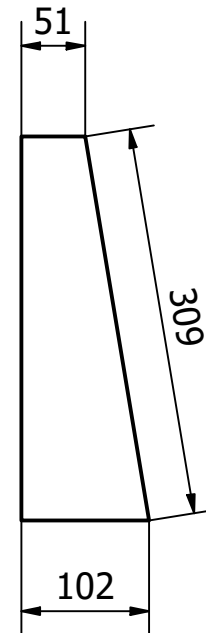
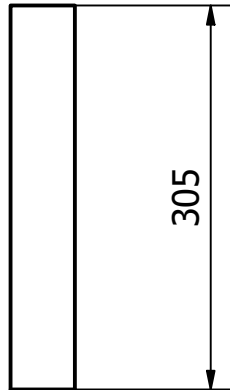
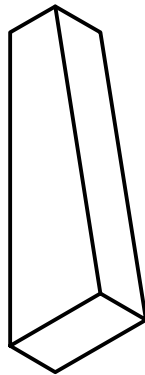

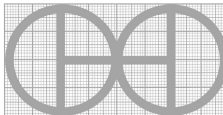
PROJECT		CREATED BY	APPROVED BY	DATE	VERSION
HANDCART		J. ROSCIANO	A. MORILLO	31/05/2021	1.1
PART NAME		FILE NAME			PART CODE
Braces		Braces.ipt			2.3
DEVELOPED BY	REDESIGNED BY	SUPPORTED BY	DOC. TYPE	MATERIAL	QUANTITY
			PART	KILN DRIED PINE	4
Unknown	OHO e.V.		LICENCE	SCALE	SHEET
			CC-BY-SA 4.0	1/6	15 /17

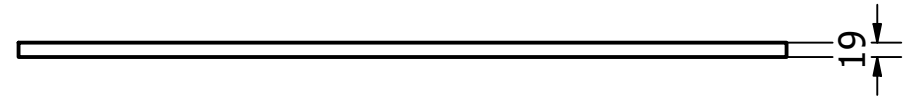
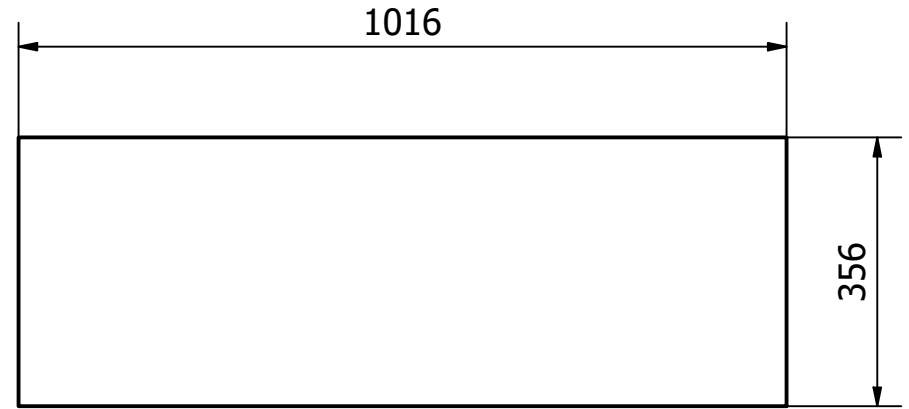
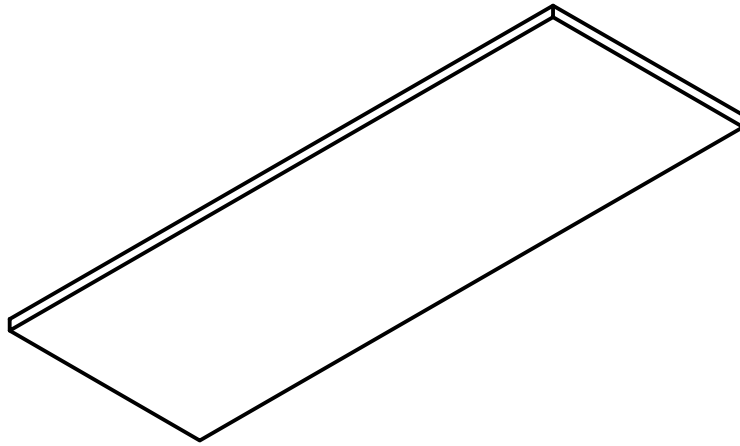

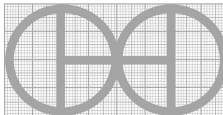
PROJECT		CREATED BY	APPROVED BY	DATE	VERSION
HANDCART		J. ROSCIANO	A. MORILLO	31/05/2021	1.1
PART NAME		FILE NAME			PART CODE
Side Panel Wall		Side Panel Wall.ipt			3.0
DEVELOPED BY	REDESIGNED BY	SUPPORTED BY	DOC. TYPE	MATERIAL	QUANTITY
			PART	KILN DRIED PINE	2
			LICENCE	SCALE	SHEET
Unknown	OHO e.V.		CC-BY-SA 4.0	1/10	16 /17

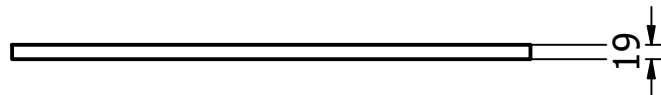
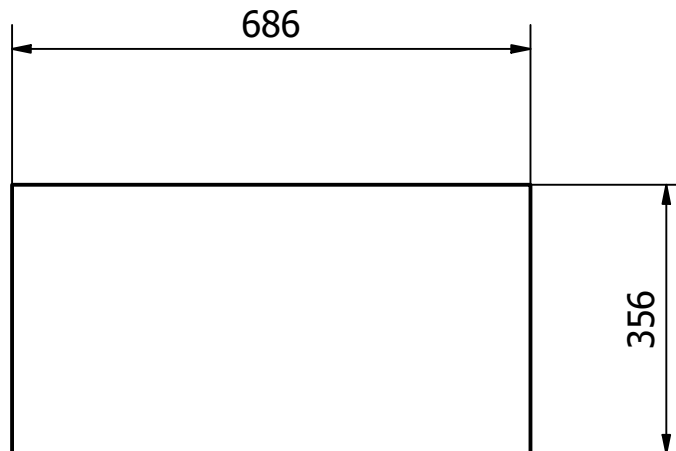
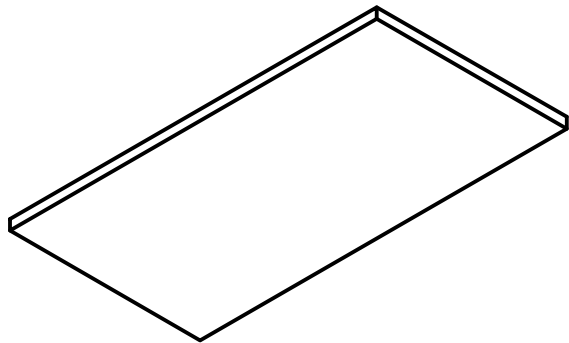

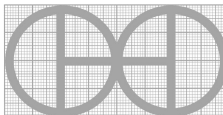
PROJECT		CREATED BY	APPROVED BY	DATE	VERSION
HANDCART		J. ROSCIANO	A. MORILLO	31/05/2021	1.1
PART NAME		FILE NAME			PART CODE
Rear Panel		Rear Panel.ipt			4.0
DEVELOPED BY	REDESIGNED BY	SUPPORTED BY	DOC. TYPE	MATERIAL	QUANTITY
			PART	KILN DRIED PINE	1
			LICENCE	SCALE	SHEET
Unknown	OHO e.V.		CC-BY-SA 4.0	1/10	17 /17