

PLAN ( 1 : 12 )

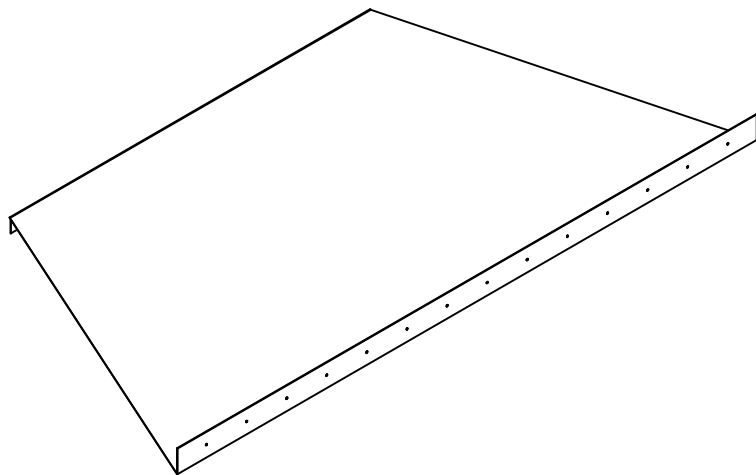
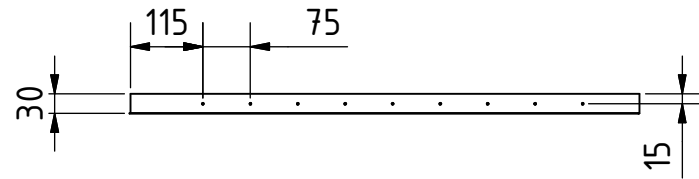
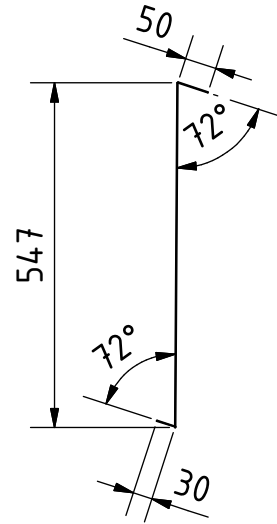
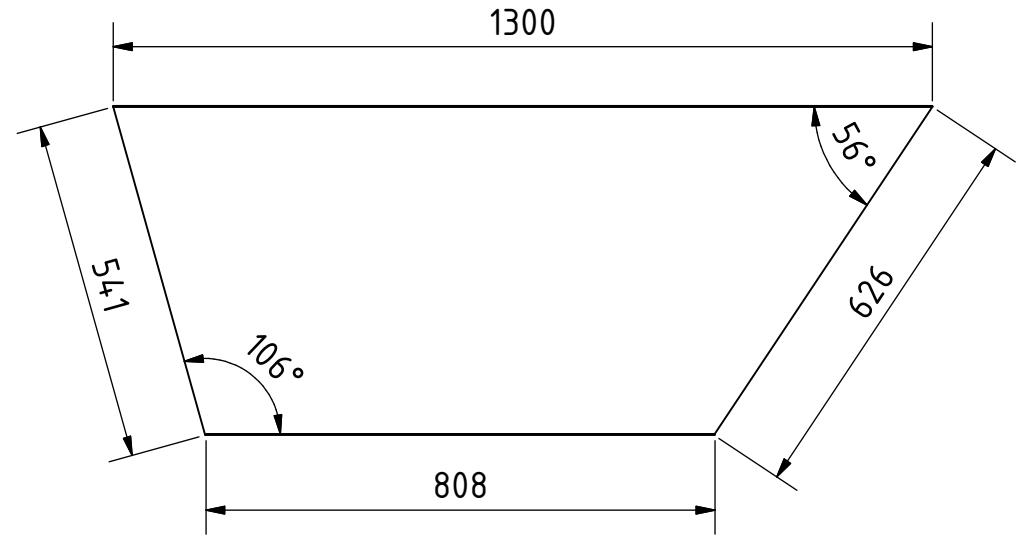
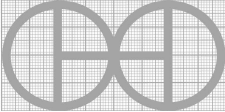

Note: All units in mm.

PROJECT	CREATED BY	APPROVED BY	DATE	VERSION
Batch Tray Dryer	J. Zeron	A. Morillo	10/08/2021	1.0
PART NAME	FILE NAME			POS
Top-under plate	Top-under plate.ipt			3.1
DEVELOPED BY	REDESIGNED BY	DOC. TYPE	MATERIAL	QUANTITY
		Part	18G Mild steel plate	4
Practical Action	OHO e.V.	LICENCE	SCALE	SHEET
		CC-BY-SA 4.0	1:12	14 /28