

A ( 1 : 4 )

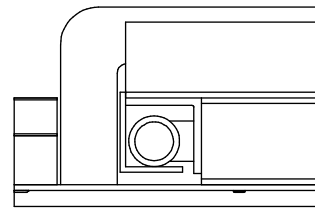

C ( 1 : 3 )

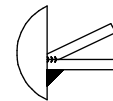

B ( 1 : 3 )

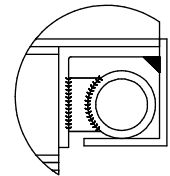

Hinweis: Alle einheiten in mm.

PROJEKT	ERSTELLT VON	GENEHMIGT VON	DATE	VERSION
Tischkreissaege	J. Zeron	A. Morillo	14/08/2021	1.0
TEIL-NAME	DATEI-NAME			TEIL-CODE
3d-Ansichten	wpo_cts_circular-table-saw.iam			A1
UMGESTALTET VON	DOK. TYP	WERKSTOFF	MENGE	
	Assembly			
LIZENZ	SCALE	SEITE		
CC-BY-SA 4.0	1:18	1 / 37		

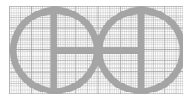

OPEN HARDWARE OBSERVATORY  
Free Blueprints for Sustainable Development

Basierend auf zeichnungen von Wood Plans Online.

OHO e.V.

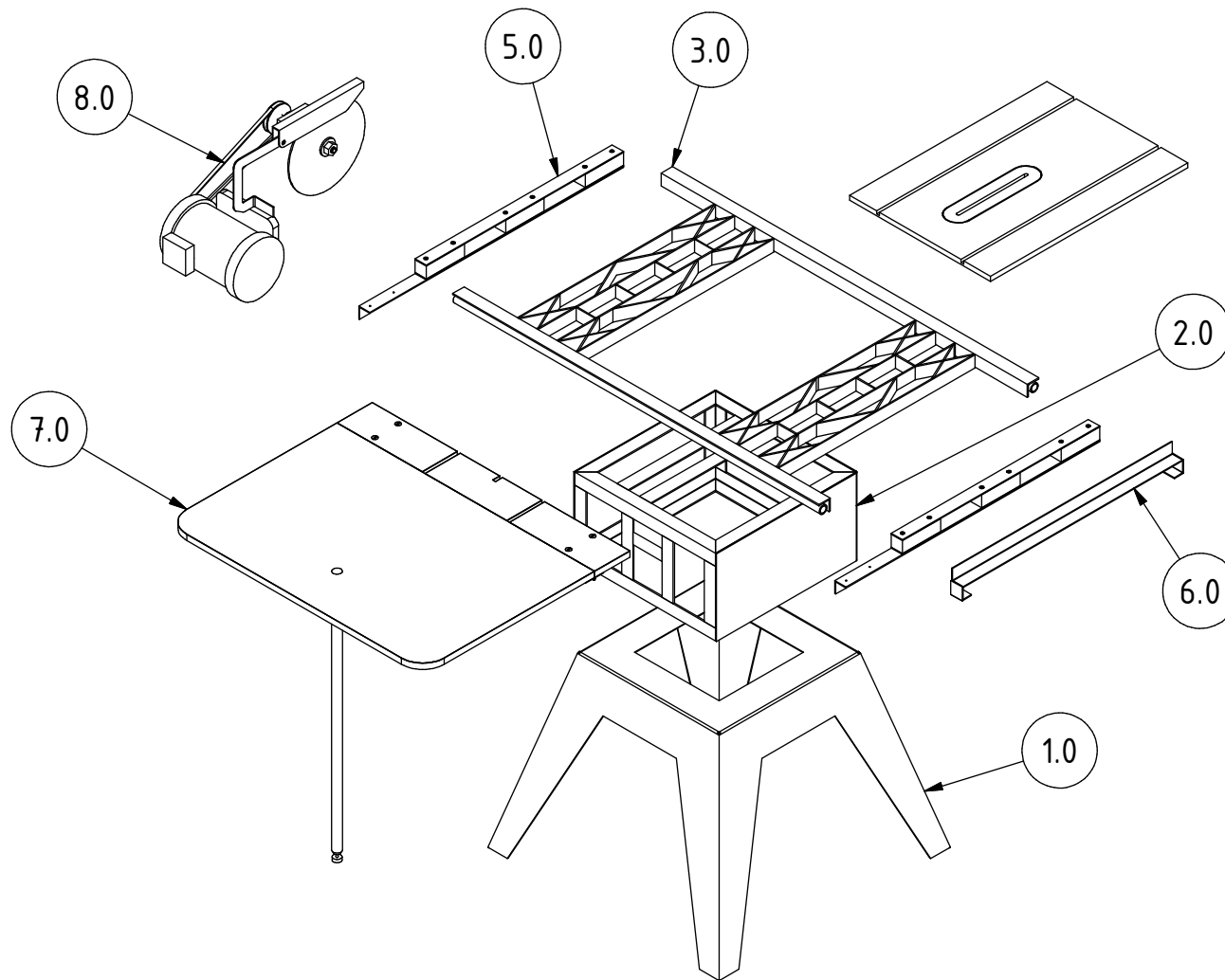

PROJEKT	ERSTELLT VON	GENEHMIGT VON	DATE	VERSION
Tischkreissaege	J. Zeron	A. Morillo	14/08/2021	1.0
TEIL-NAME	DATEI-NAME			TEIL-CODE
3d-Explosionszeichnungen	wpo_cts_circular-table-saw.ipn			A2
UMGESTALTET VON	DOK. TYP	WERKSTOFF	MENGE	
 <b>OPEN HARDWARE OBSERVATORY</b> Free Blueprints for Sustainable Development	Assembly			
	LIZENZ	SCALE	SEITE	
OHO e.V.	CC-BY-SA 4.0	1:20	2 /37	

## Parts list

POS	QTY	TEIL NAME	DATEI-NAME	TEIL-TYP	SPEZIFIKATIONEN	SEITE
A1	-	3d-Ansichten	wpo_cts_circular-table-saw.iam	-	-	1
A2	-	3d-Explosionszeichnungen	wpo_cts_circular-table-saw.ipn	-	-	2
B1	-	Teileliste	wpo_cts_circular-table-saw.csv	-	-	3-4
1.0	-	Base	Base.ipn	-	-	5
1.1	4	Blechbasis A	Sheet base A.ipt	Production	Stahlblech C45 3mm	6
1.2	1	Blechbasis B	Sheet base A.ipt	Production	Stahlblech C45 3mm	7
2.0	-	Spindelkasten	Spindle box.ipn	-	-	8
2.1	8	Winkel A	Angle A.ipt	Production	Stahl A36 winkel 40x40x4mm	9
2.2	4	Winkel B	-	Production	Stahl A36 winkel 40x40x4x190mm	-
2.3	2	Winkel C	Angle C.ipt	Production	Stahl A36 winkel 40x40x4mm	10
2.4	1	Winkel D	Angle D.ipt	Production	Stahl A36 winkel 40x40x4mm	11
2.5	2	Obere flache stange	-	Production	Flachstahl A36 40x4x420mm	-
2.6	1	Abdeckung	Cover.ipt	Production	Stahlblech C45 3mm	12
3.0	-	Verlängerungswind	Extension wind.ipn	-	-	13
3.1	2	Rahmenwinkel	-	Production	Stahl A36 winkel 40x40x4x1300mm	-
3.2	6	Sube rohre	Cute tube.ipt	Production	DIN 10210-2_21.3x2.3mm schwarzes eisenrohr	14
3.3	2	Langes rohr	-	Production	DIN 10210-2_26.9x3.2mm schwarzes eisenrohr L:1300mm	-
3.4	8	Platte A	-	Production	Flechstahl A36 40x4x700mm	-
3.5	16	Platte B	Plate B.ipt	Production	Flechstahl A36 40x4mm	15
3.6	8	Platte C	Plate C.ipt	Production	Flechstahl A36 40x4mm	16
3.7	8	Platte D	-	Production	Flechstahl A36 40x4x66mm	-
4.0	-	Bett	Bed.ipn	-	-	17
4.1	1	Splitter	Splitter.ipt	Production	Aluminium 15mm	18
4.2	1	Scheibenkappe	Disc cap.ipt	Production	Aluminium 10mm	19
5.0	-	Montageleiste	Mounting bar.ipn	-	-	20
5.1	2	Winkel	Angle.ipt	Production	Stahl A36 winkel 40x40x4mm	21
5.2	2	Distanzblock	Spacer block.ipt	Production	Hartholz 3mm	22
5.3	6	Fullblock	Filler block.ipt	Production	Hartholz 40x40x136mm	23
5.4	2	Platte	Plate.ipt	Production	Flechstahl A36 40x3mm	24
5.5	12	Schrauben A	-	Standard	ISO 4014 M6x55mm	-

PROJEKT	ERSTELLT VON	GENEHMIGT VON	DATE	VERSION
Tischkreissaege	J. Zeron	A. Morillo	14/08/2021	1.0
TEIL-NAME	DATEI-NAME			TEIL-CODE
Teileliste	wpo_cts_circular-table-saw.csv			B1
UMGESTALTET VON	DOK. TYP	WERKSTOFF	MENGE	
 <b>OPEN HARDWARE OBSERVATORY</b> Free Blueprints for Sustainable Development	Parts list			
	LIZENZ	SCALE	SEITE	
OHO e.V.	CC-BY-SA 4.0		3 /37	

## Parts list

POS	QTY	TEIL NAME	DATEI-NAME	TEIL-TYP	SPEZIFIKATIONEN	SEITE
6.0	-	Zaun	Fence.ipn	-	-	25
6.1	1	Winkelanschlag A	-	Production	Stahl A36 winkel 40x40x3x780mm	-
6.2	2	Winkelanschlag B	-	Production	Stahl A36 winkel 40x40x3x40mm	-
7.0	-	Erweiterungstisch	Extension table.ipn	-	-	26
7.1	1	Erweiterungstisch	Extension table.ipt	Production	Sperrholz 20mm	27
7.2	1	Fester tisch	Fixed table.ipt	Production	Sperrholz 20mm	28
7.3	1	Scharnier	-	Buy	Durchgehendes edelstahlscharnier 50x910mm swing 180	-
7.4	2	Montageblock	Mounting block.ipt	Production	Hartholz 26mm	29
7.5	4	Schraube B	-	Standard	ISO 4014 M10x50mm	-
7.6	1	Beinführung	Leg guide.ipt	Production	Hartholz 30mm	30
7.7	1	Bein	-	Production	Aluminiumrohr 1" L:838mm SH40	-
7.8	1	Adapter	Adapter.ipt	Production	Stahl C45 geharteter stab 20mm	31
7.9	1	Verstellbarer bodengleiter	-	Buy	Schwarze nylonbasis 8x25mm	-
7.10	2	Laminat C	Laminate C.ipt	Production	Kunststofflaminat HPL 1.2mm	32
7.11	4	Laminat D	Laminate D.ipt	Production	Kunststofflaminat HPL 1.2mm	33
7.12	2	Laminat E	Laminate E.ipt	Production	Kunststofflaminat HPL 1.2mm	34
7.13	3	Schraube C	-	Standard	DIN 7046 M3x40mm	-
8.0	-	Sagekomponenten	Saw components.ipn	-	-	35
8.1	1	Motor	-	Buy	Leeson 2 HP, 3450 RPM, 115/230 V	-
8.2	1	Spindel	-	Buy	Exellence tischkreissagespindel 206	-
8.3	1	Rillenscheibe A	-	Buy	Bohrung einzelnut 20mm abschnitt, 84 mm	-
8.4	1	Rillenscheibe B	-	Buy	Bohrung einzelnut 20mm abschnitt, 54 mm	-
8.5	1	Gurtel	-	Buy	Gurtel 12mm DIN 7721 lange 946mm	-
8.6	1	Klinge	-	Buy	Hartmetallbestucktes sageblatt 285mm	-
8.7	1	Spatmesser	Riving knife.ipt	Production	Flechstahl C45 30x3mm	36
8.8	1	Klingenschutz	Blade guard.ipt	Production	Acetat oder polycarbonat 3mm	37
8.9	1	Schraube D	-	Standard	DIN 464 M6x30	-

PROJEKT	ERSTELLT VON	GENEHMIGT VON	DATE	VERSION
Tischkreissaege	J. Zeron	A. Morillo	14/08/2021	1.0
TEIL-NAME	DATEI-NAME			TEIL-CODE
Teileliste	wpo_cts_circular-table-saw.csv			B1
UMGESTALTET VON	DOK. TYP	WERKSTOFF	MENGE	
 <b>OPEN HARDWARE OBSERVATORY</b> Free Blueprints for Sustainable Development	Parts list			
	LIZENZ	SCALE	SEITE	
OHO e.V.	CC-BY-SA 4.0		4 /37	

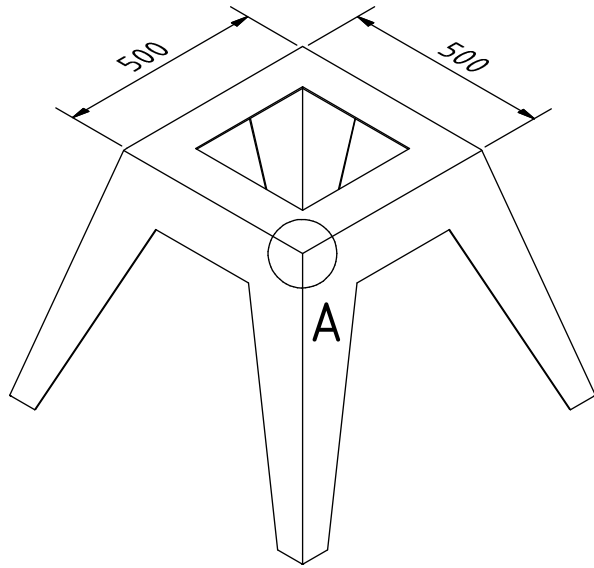

A ( 1 : 4 )

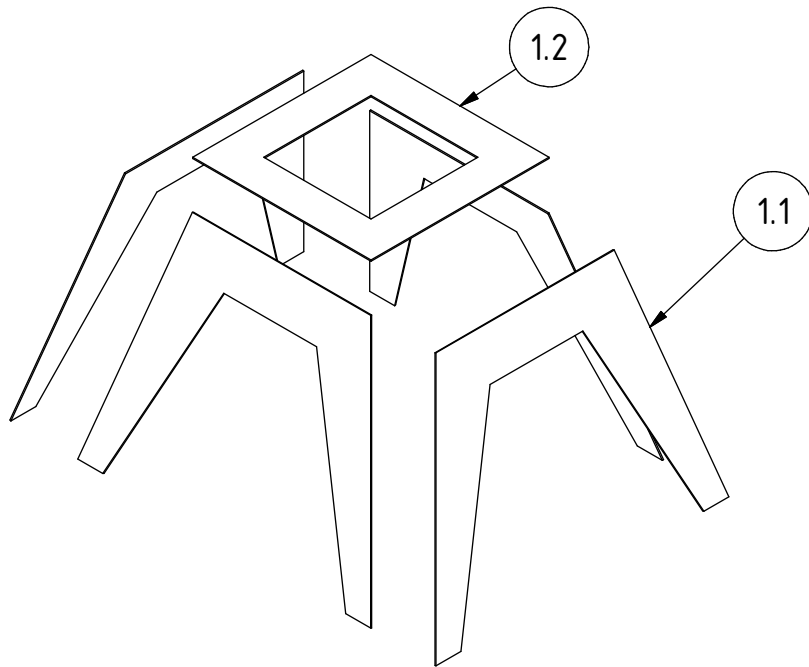
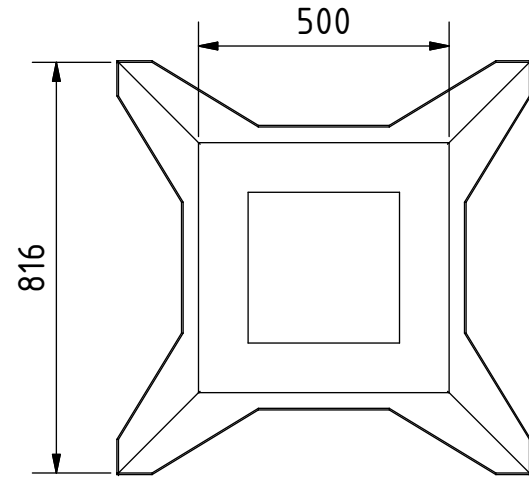
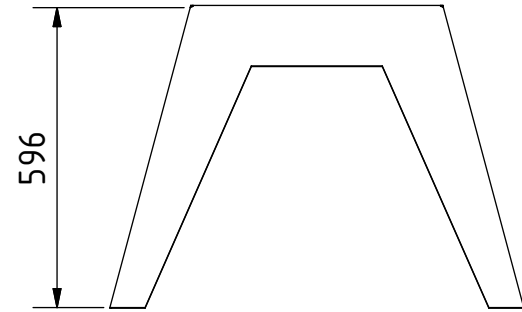
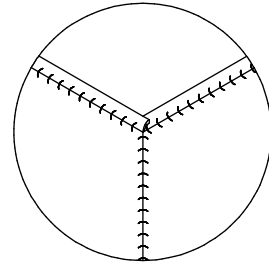

Hinweis: Alle einheiten in mm.

PROJEKT	ERSTELLT VON	GENEHMIGT VON	DATE	VERSION
Tischkreissaege	J. Zeron	A. Morillo	14/08/2021	1.0
TEIL-NAME	DATEI-NAME			TEIL-CODE
Base	Base.ipn			1.0
UMGESTALTET VON	DOK. TYP	WERKSTOFF	MENGE	
 <b>OPEN HARDWARE OBSERVATORY</b> Free Blueprints for Sustainable Development	Assembly			
	LIZENZ	SCALE	SEITE	
OHO e.V.	CC-BY-SA 4.0	1:15	5 /37	

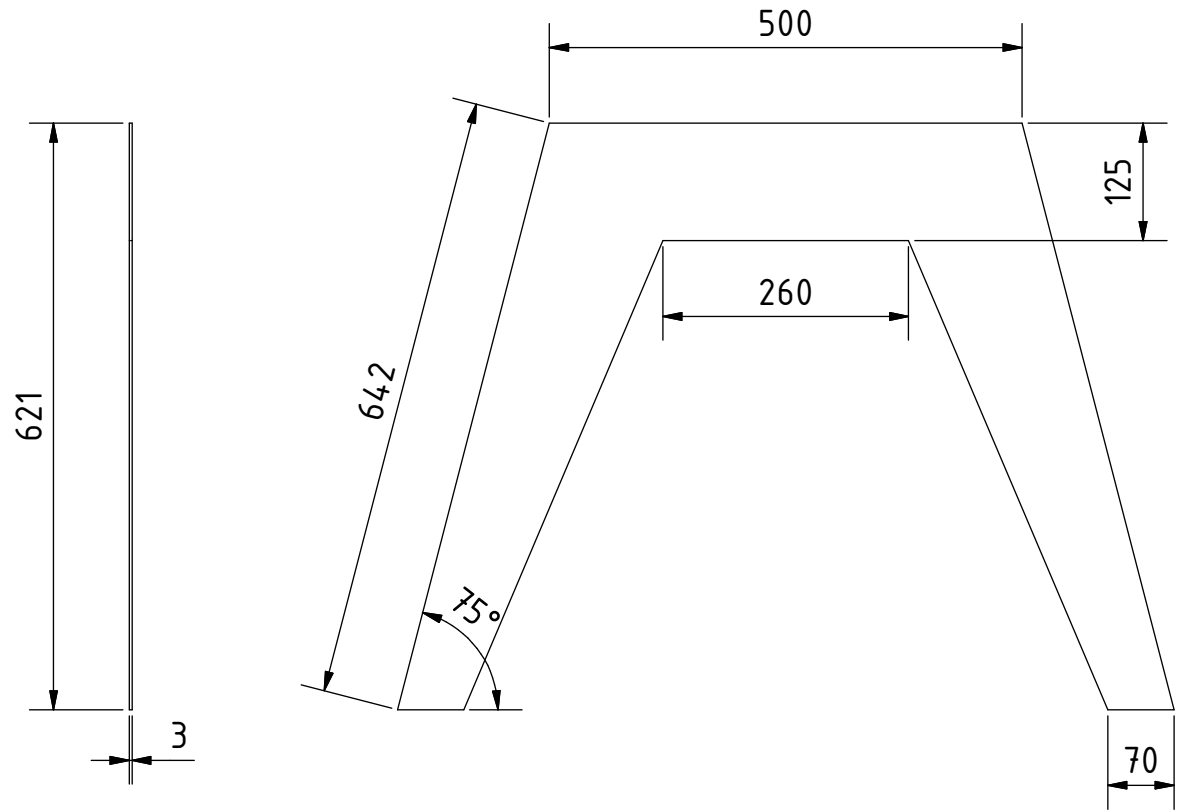
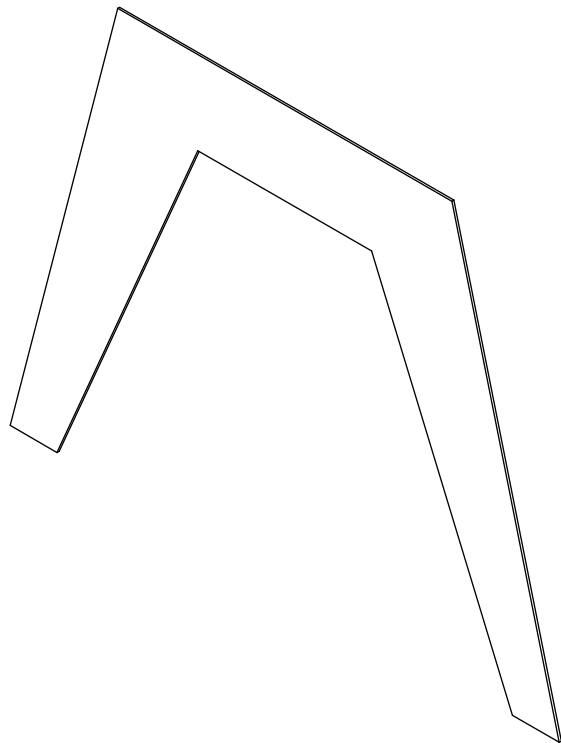

Hinweis: Alle einheiten in mm.

PROJEKT	ERSTELLT VON	GENEHMIGT VON	DATE	VERSION
Tischkreissaege	J. Zeron	A. Morillo	14/08/2021	1.0
TEIL-NAME	DATEI-NAME			TEIL-CODE
Blechbasis A	Sheet base A.ipt			1.1
UMGESTALTET VON	DOK. TYP	WERKSTOFF	MENGE	
 <b>OPEN HARDWARE OBSERVATORY</b> Free Blueprints for Sustainable Development	Part	Stahl C45	4	
	LIZENZ	SCALE	SEITE	
OHO e.V.	CC-BY-SA 4.0	1:8	6 /37	

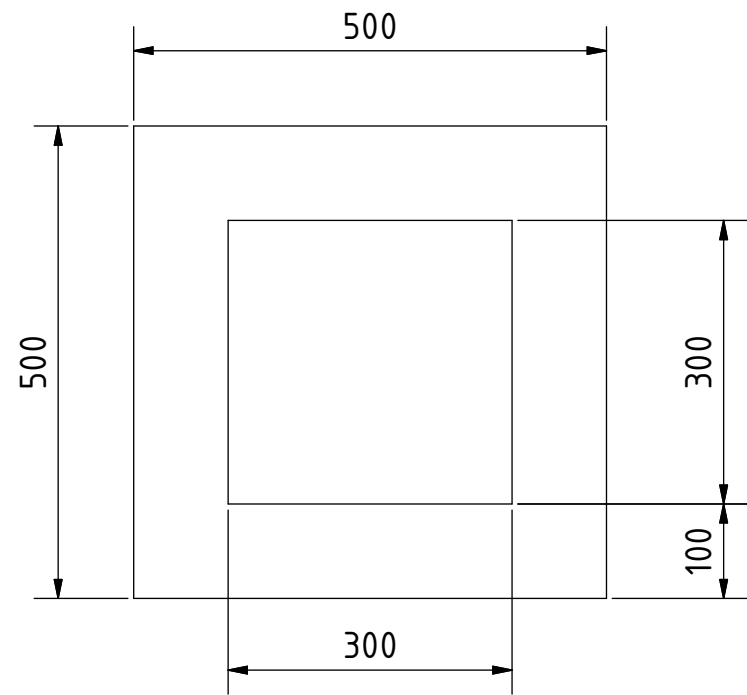
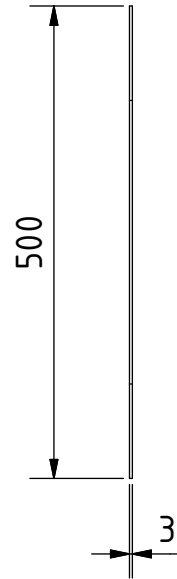
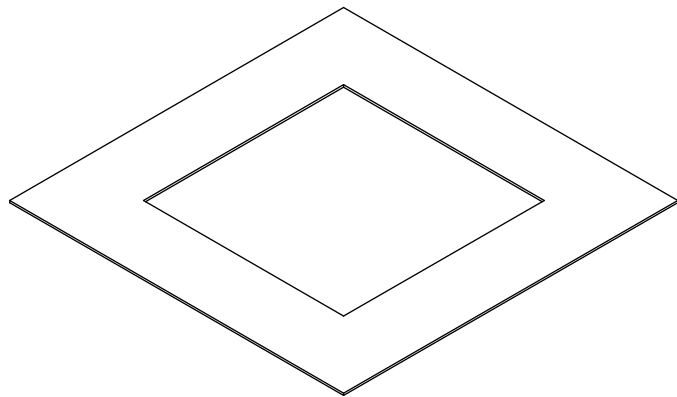

Hinweis: Alle einheiten in mm.

PROJEKT	ERSTELLT VON	GENEHMIGT VON	DATE	VERSION
Tischkreissaege	J. Zeron	A. Morillo	14/08/2021	1.0
TEIL-NAME	DATEI-NAME			TEIL-CODE
Blechbasis B	Sheet base A.ipt			1.2
UMGESTALTET VON	DOK. TYP	WERKSTOFF	MENGE	
 <b>OPEN HARDWARE OBSERVATORY</b> Free Blueprints for Sustainable Development	Part	Stahl C45	1	
	LIZENZ	SCALE	SEITE	
OHO e.V.	CC-BY-SA 4.0	1:8	7 /37	

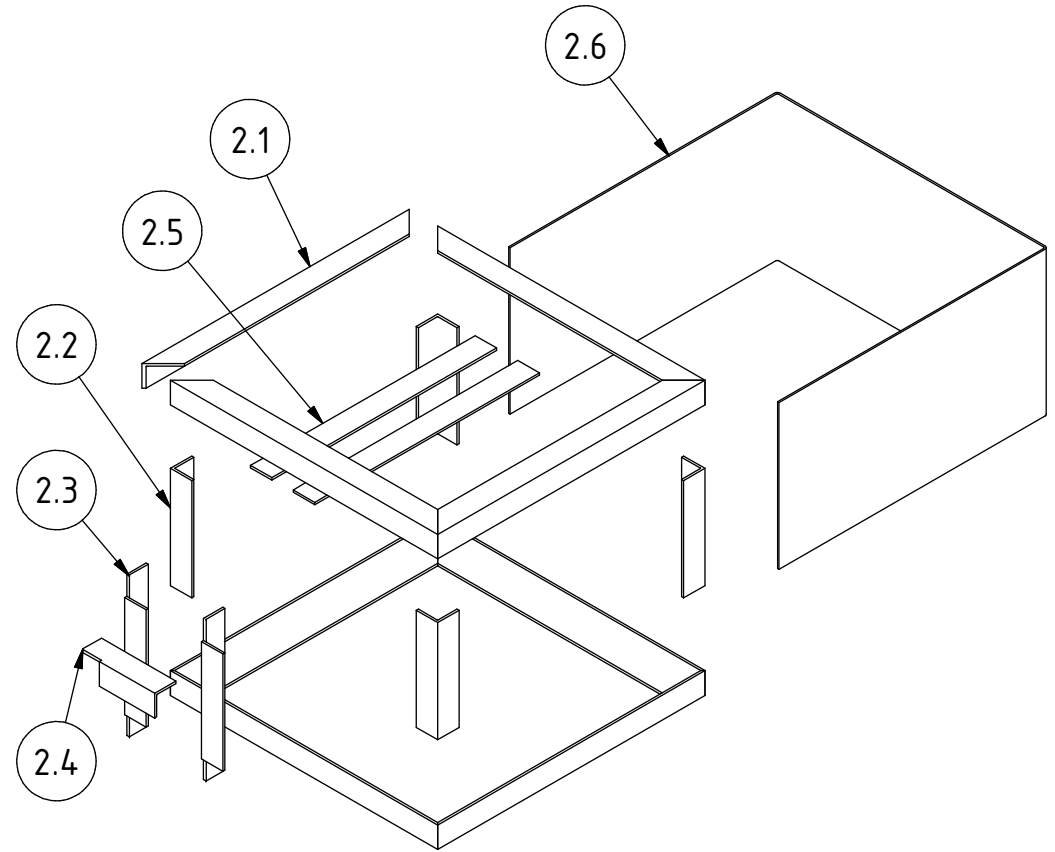
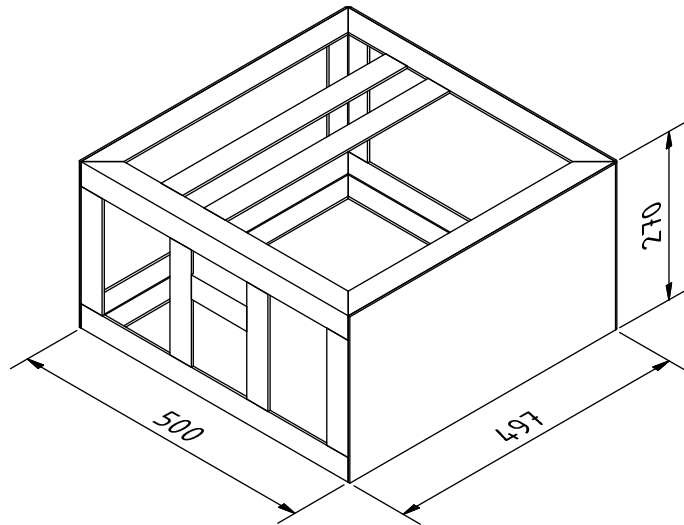
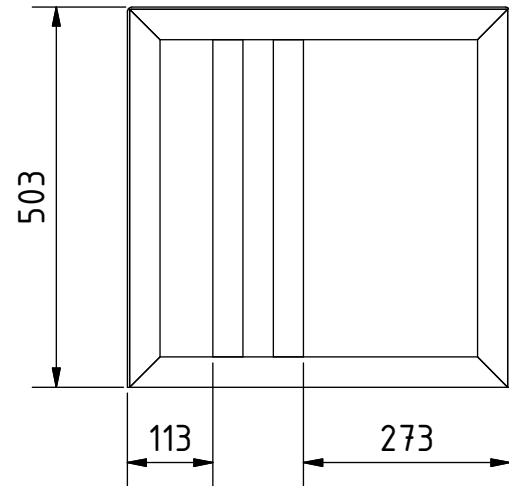
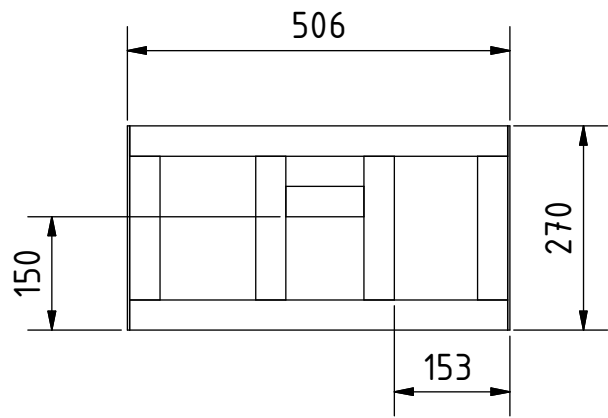

Alle teile sind geschweibt.  
Hinweis: Alle einheiten in mm.

PROJEKT	ERSTELLT VON	GENEHMIGT VON	DATE	VERSION
Tischkreissaege	J. Zeron	A. Morillo	14/08/2021	1.0
TEIL-NAME	DATEI-NAME			TEIL-CODE
Spindelkasten	Spindle box.ipn			2.0
UMGESTALTET VON	DOK. TYP	WERKSTOFF	MENGE	
 <b>OPEN HARDWARE OBSERVATORY</b> Free Blueprints for Sustainable Development	Assembly			
	LIZENZ	SCALE	SEITE	
OHO e.V.	CC-BY-SA 4.0	1:10	8 /37	



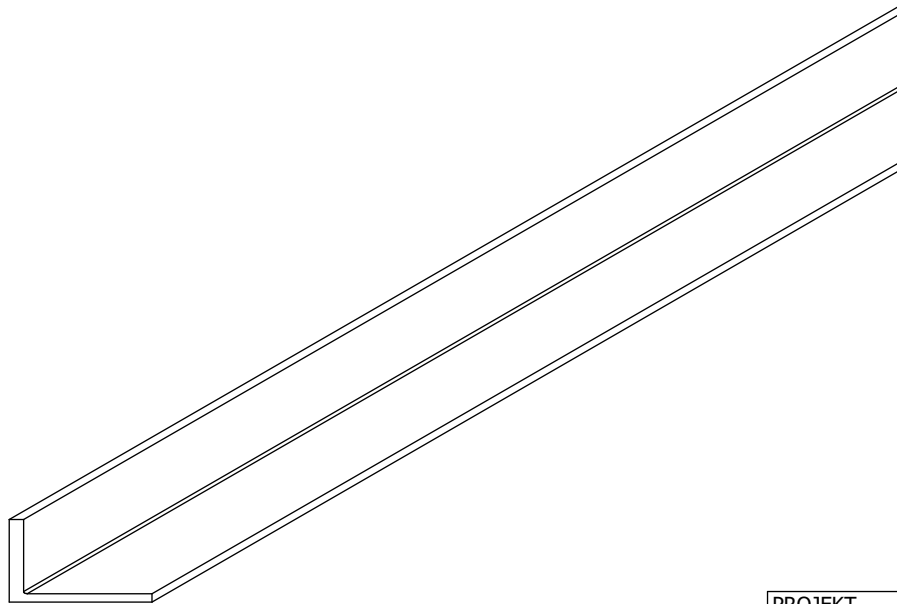
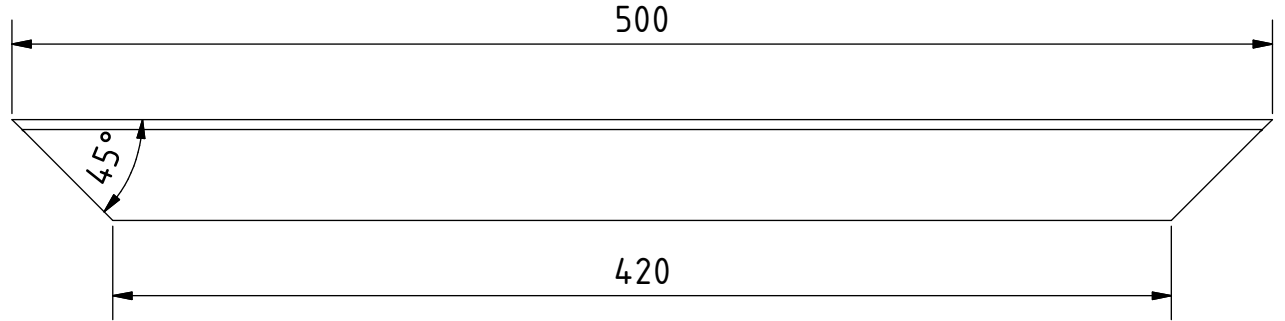
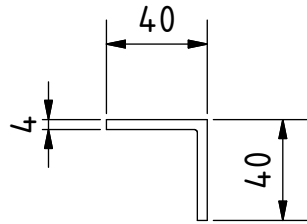

Hinweis: Alle einheiten in mm.

PROJEKT	ERSTELLT VON	GENEHMIGT VON	DATE	VERSION
Tischkreissaege	J. Zeron	A. Morillo	14/08/2021	1.0
TEIL-NAME	DATEI-NAME			TEIL-CODE
Winkel A	Angle A.ipt			2.1
UMGESTALTET VON	DOK. TYP	WERKSTOFF	MENGE	
 <b>OPEN HARDWARE OBSERVATORY</b> Free Blueprints for Sustainable Development	Part	Stahl A36	8	
	LIZENZ	SCALE	SEITE	
OHO e.V.	CC-BY-SA 4.0	1:3	9 /37	

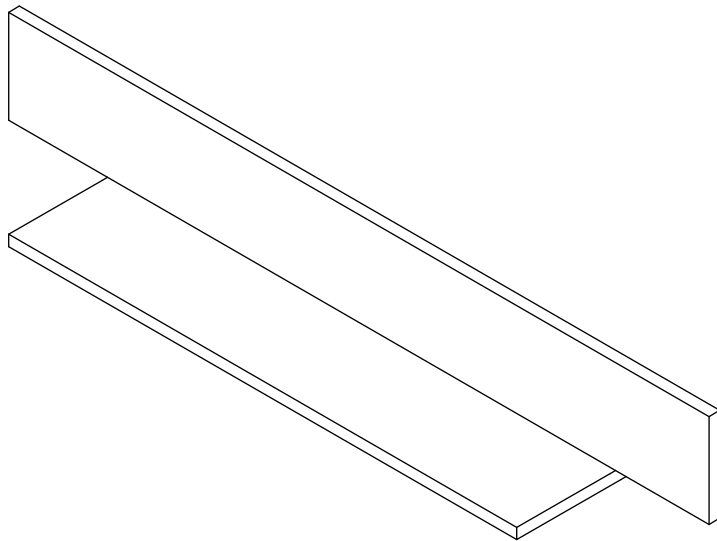
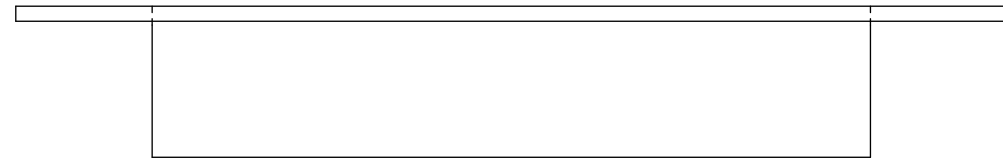
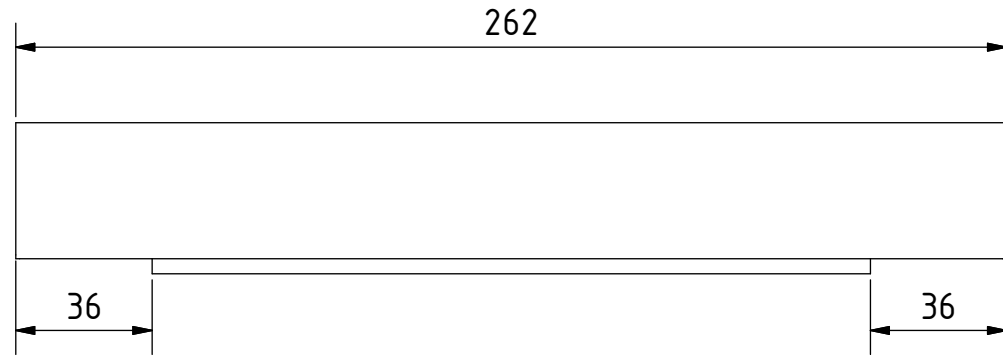
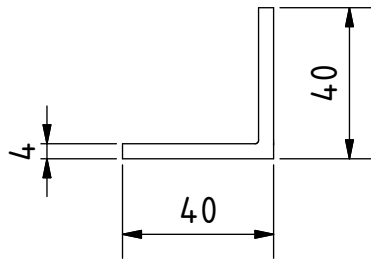

Hinweis: Alle einheiten in mm.

PROJEKT	ERSTELLT VON	GENEHMIGT VON	DATE	VERSION
Tischkreissaege	J. Zeron	A. Morillo	14/08/2021	1.0
TEIL-NAME	DATEI-NAME			TEIL-CODE
Winkel C	Angle C.ipt			2.3
UMGESTALTET VON	DOK. TYP	WERKSTOFF	MENGE	
 <b>OPEN HARDWARE OBSERVATORY</b> Free Blueprints for Sustainable Development	Part	Stahl A36	2	
	LIZENZ	SCALE	SEITE	
OHO e.V.	CC-BY-SA 4.0	1:2	10 /37	

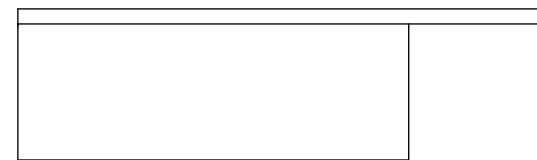
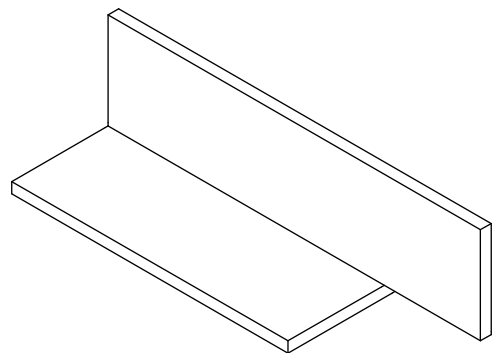
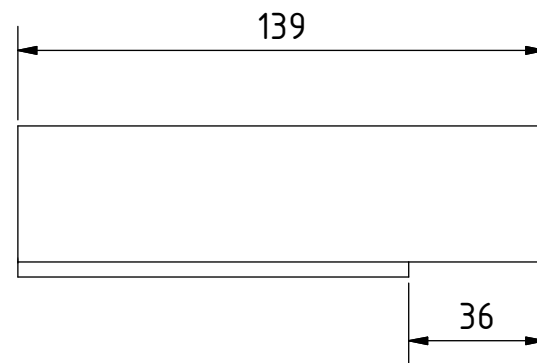
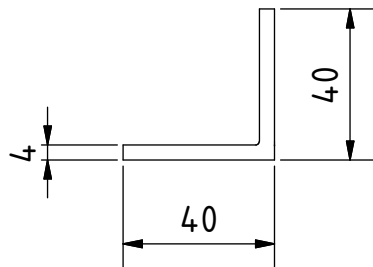

Hinweis: Alle einheiten in mm.

PROJEKT	ERSTELLT VON	GENEHMIGT VON	DATE	VERSION
Tischkreissaege	J. Zeron	A. Morillo	14/08/2021	1.0
TEIL-NAME	DATEI-NAME			TEIL-CODE
Winkel D	Angle D.ipt			2.4
UMGESTALTET VON	DOK. TYP	WERKSTOFF	MENGE	
 <b>OPEN HARDWARE OBSERVATORY</b> Free Blueprints for Sustainable Development	Part	Stahl A36	1	
	LIZENZ	SCALE	SEITE	
OHO e.V.	CC-BY-SA 4.0	1:2	11 /37	

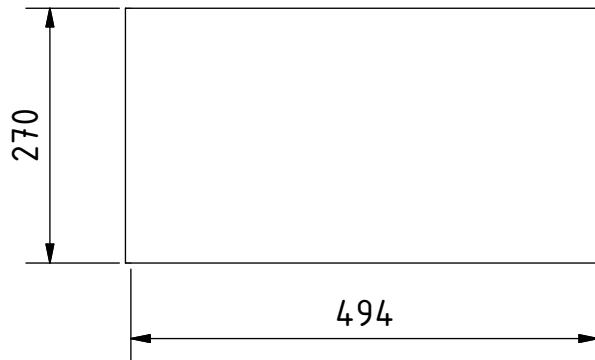
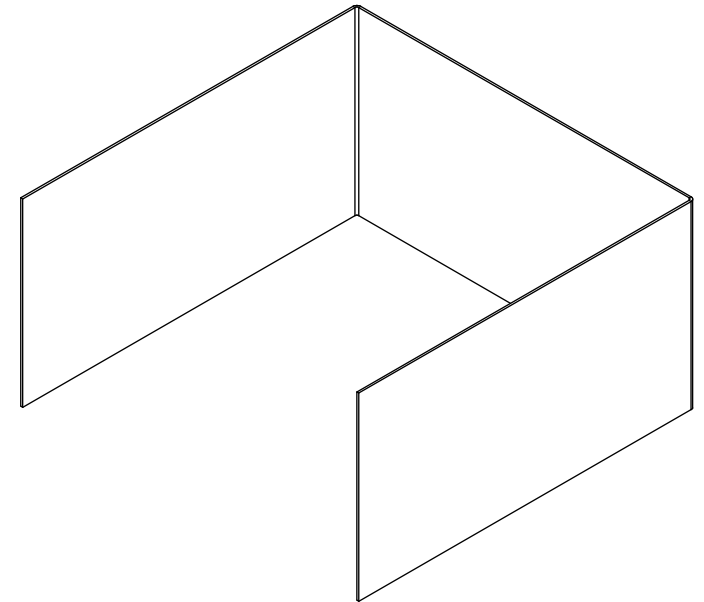
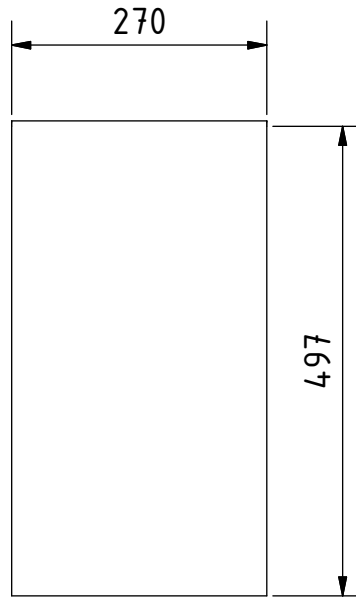
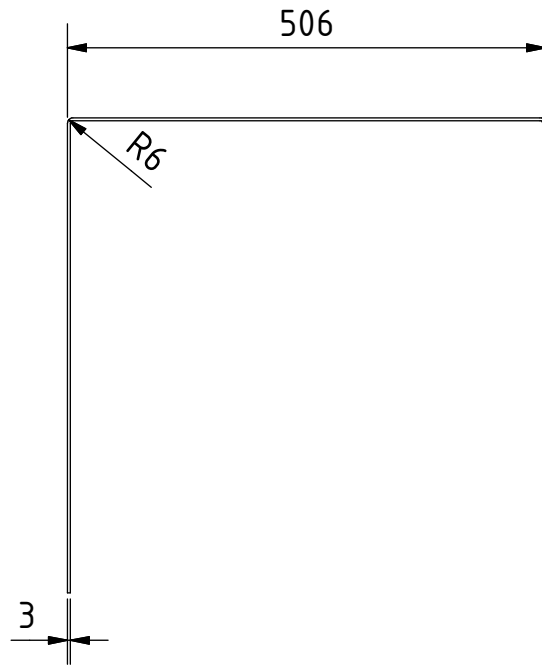

Hinweis: Alle einheiten in mm.

PROJEKT	ERSTELLT VON	GENEHMIGT VON	DATE	VERSION
Tischkreissaege	J. Zeron	A. Morillo	14/08/2021	1.0
TEIL-NAME	DATEI-NAME			TEIL-CODE
Abdeckung	Cover.ipt			2.6
UMGESTALTET VON	DOK. TYP	WERKSTOFF	MENGE	
 <b>OPEN HARDWARE OBSERVATORY</b> Free Blueprints for Sustainable Development	Part	Stahl C45	1	
	LIZENZ	SCALE	SEITE	
OHO e.V.	CC-BY-SA 4.0	1:8	12 /37	

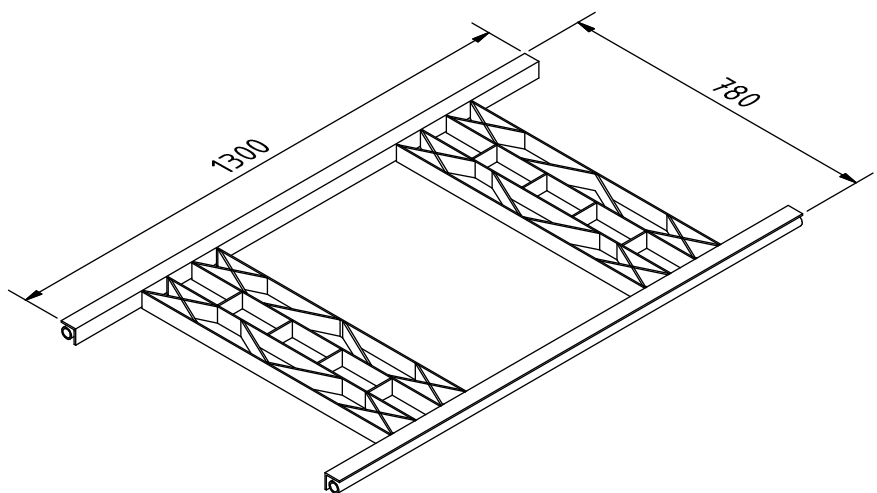
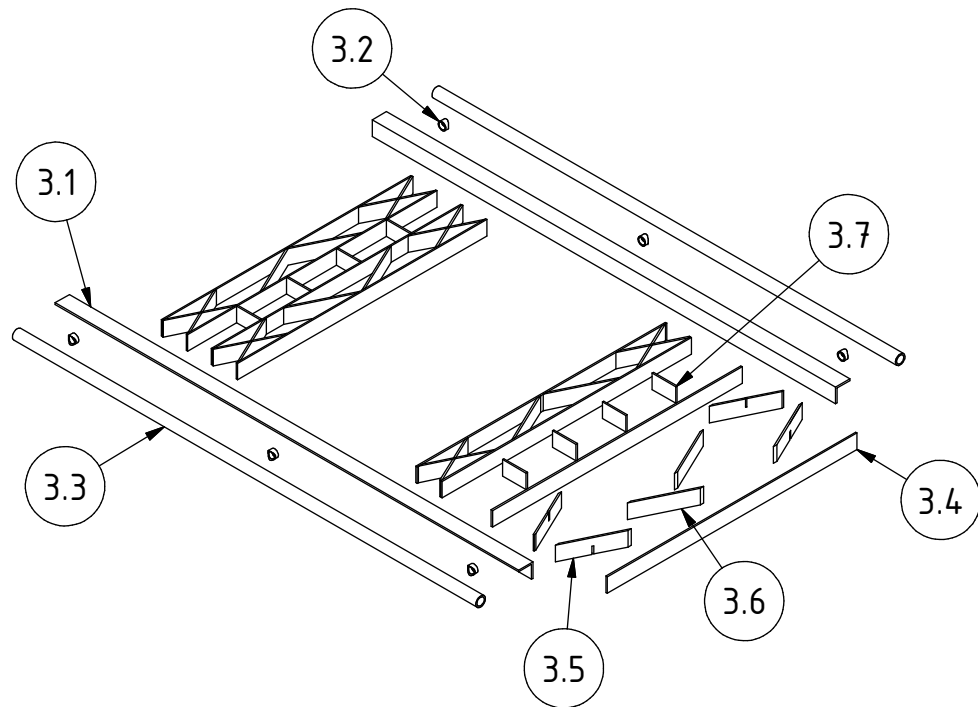
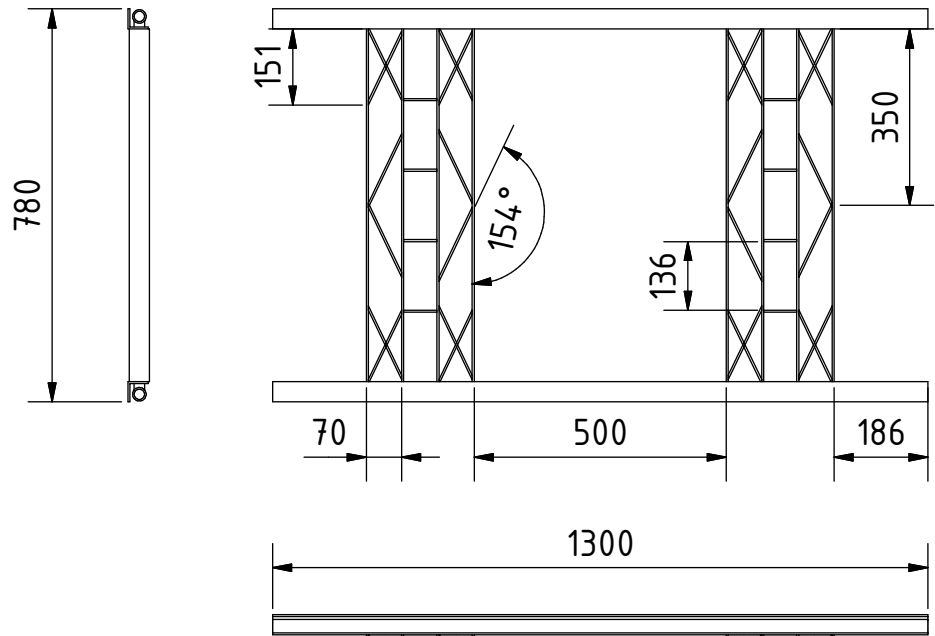

Alle teile sind geschweißt.  
Hinweis: Alle einheiten in mm.

PROJEKT	ERSTELLT VON	GENEHMIGT VON	DATE	VERSION
Tischkreissaeg	J. Zeron	A. Morillo	14/08/2021	1.0
TEIL-NAME	DATEI-NAME			TEIL-CODE
Verlangerungswind	Extension wind.ipn			3.0
UMGESTALTET VON	DOK. TYP	WERKSTOFF	MENGE	
 <b>OPEN HARDWARE OBSERVATORY</b> Free Blueprints for Sustainable Development	Assembly			
	LIZENZ	SCALE	SEITE	
OHO e.V.	CC-BY-SA 4.0	1:15	13 /37	

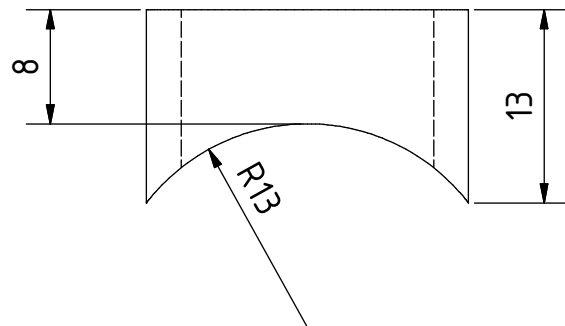
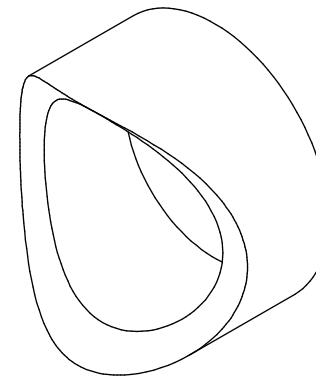
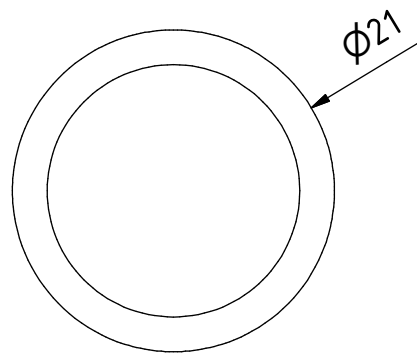

Hinweis: Alle einheiten in mm.

PROJEKT	ERSTELLT VON	GENEHMIGT VON	DATE	VERSION
Tischkreissaege	J. Zeron	A. Morillo	14/08/2021	1.0
TEIL-NAME	DATEI-NAME			TEIL-CODE
Sube rohre	Cute tube.ipt			3.2
UMGESTALTET VON	DOK. TYP	WERKSTOFF	MENGE	
 <b>OPEN HARDWARE OBSERVATORY</b> Free Blueprints for Sustainable Development	Part	Schwarzes eisen	6	
	LIZENZ	SCALE	SEITE	
OHO e.V.	CC-BY-SA 4.0	2:1	14 /37	

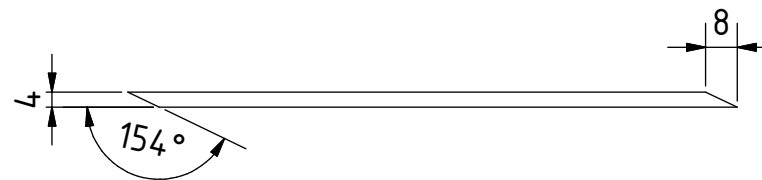
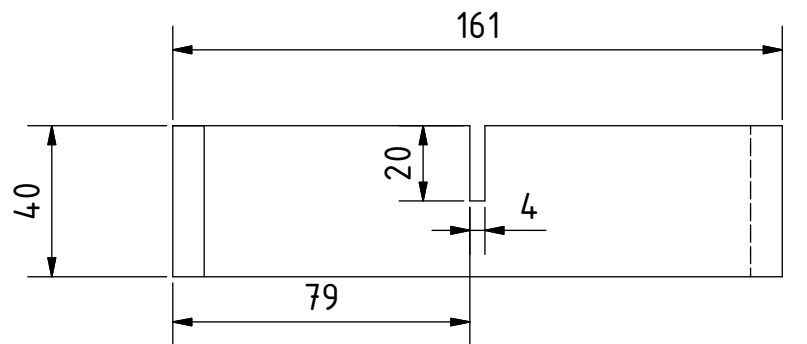
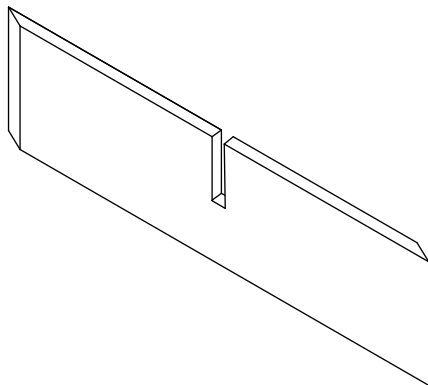

Hinweis: Alle einheiten in mm.

PROJEKT	ERSTELLT VON	GENEHMIGT VON	DATE	VERSION
Tischkreissaege	J. Zeron	A. Morillo	14/08/2021	1.0
TEIL-NAME	DATEI-NAME			TEIL-CODE
Platte B	Plate B.ipt			3.5
UMGESTALTET VON	DOK. TYP	WERKSTOFF	MENGE	
 <b>OPEN HARDWARE OBSERVATORY</b> Free Blueprints for Sustainable Development	Part	Stahl C45	16	
	LIZENZ	SCALE	SEITE	
OHO e.V.	CC-BY-SA 4.0	1:2	15 /37	

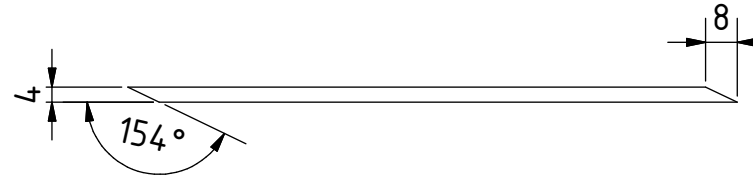
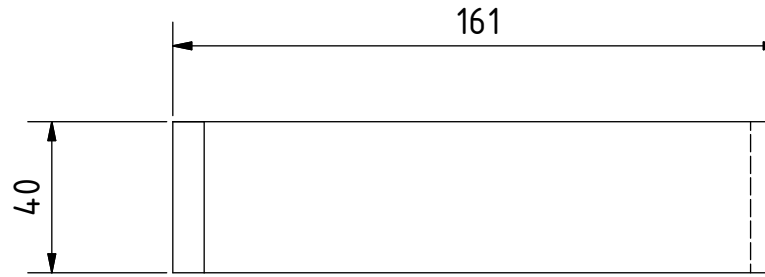
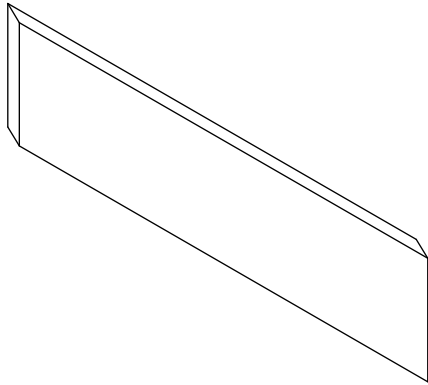

Hinweis: Alle einheiten in mm.

PROJEKT	ERSTELLT VON	GENEHMIGT VON	DATE	VERSION
Tischkreissaege	J. Zeron	A. Morillo	14/08/2021	1.0
TEIL-NAME	DATEI-NAME			TEIL-CODE
Platte C	Plate C.ipt			3.6
UMGESTALTET VON	DOK. TYP	WERKSTOFF	MENGE	
 <b>OPEN HARDWARE OBSERVATORY</b> Free Blueprints for Sustainable Development	Part	Stahl A36	8	
	LIZENZ	SCALE	SEITE	
OHO e.V.	CC-BY-SA 4.0	1:2	16 /37	



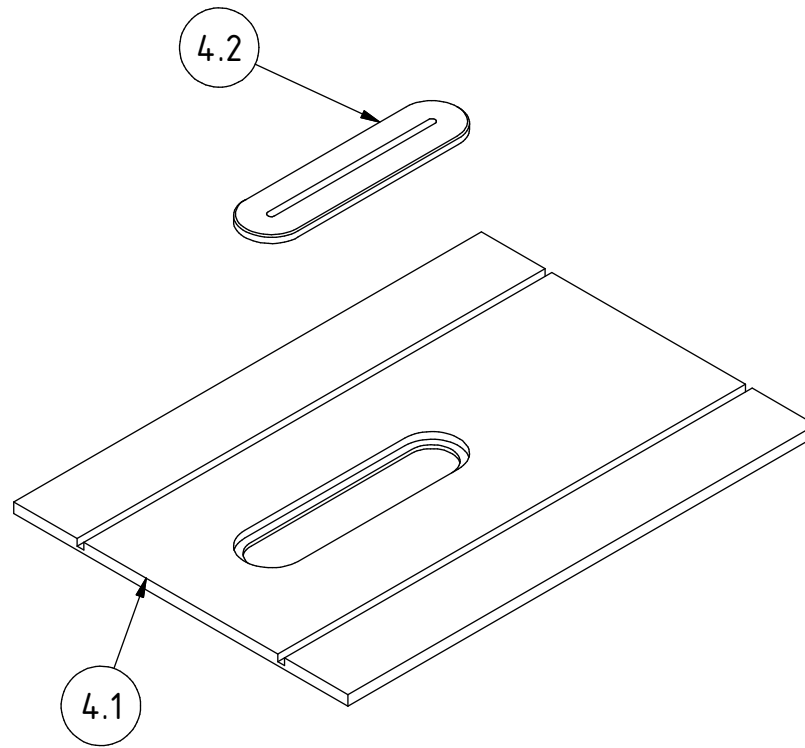

Hinweis: Alle einheiten in mm.

PROJEKT	ERSTELLT VON	GENEHMIGT VON	DATE	VERSION
Tischkreissaege	J. Zeron	A. Morillo	14/08/2021	1.0
TEIL-NAME	DATEI-NAME			TEIL-CODE
Bett	Bed.ipn			4.0
UMGESTALTET VON	DOK. TYP	WERKSTOFF	MENGE	
 <b>OPEN HARDWARE OBSERVATORY</b> Free Blueprints for Sustainable Development	Assembly			
	LIZENZ	SCALE	SEITE	
OHO e.V.	CC-BY-SA 4.0	1:8	17 /37	

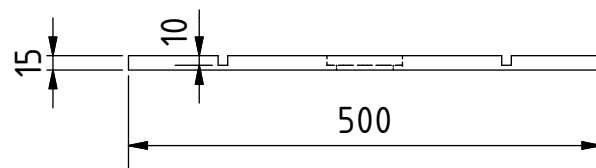
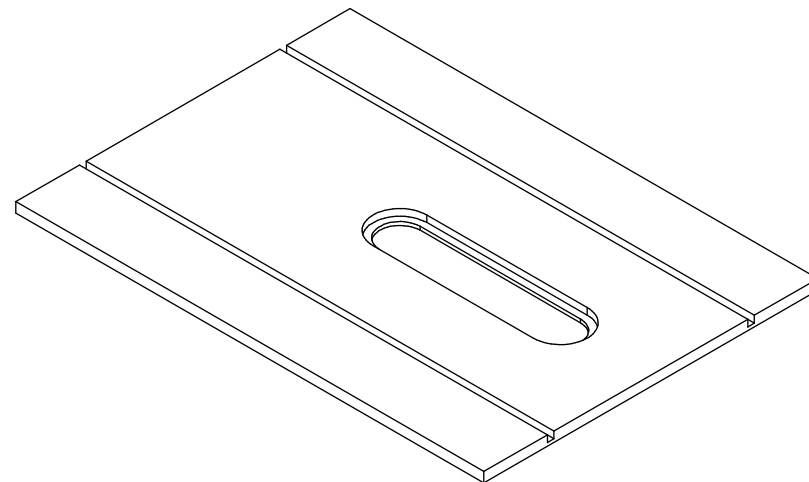
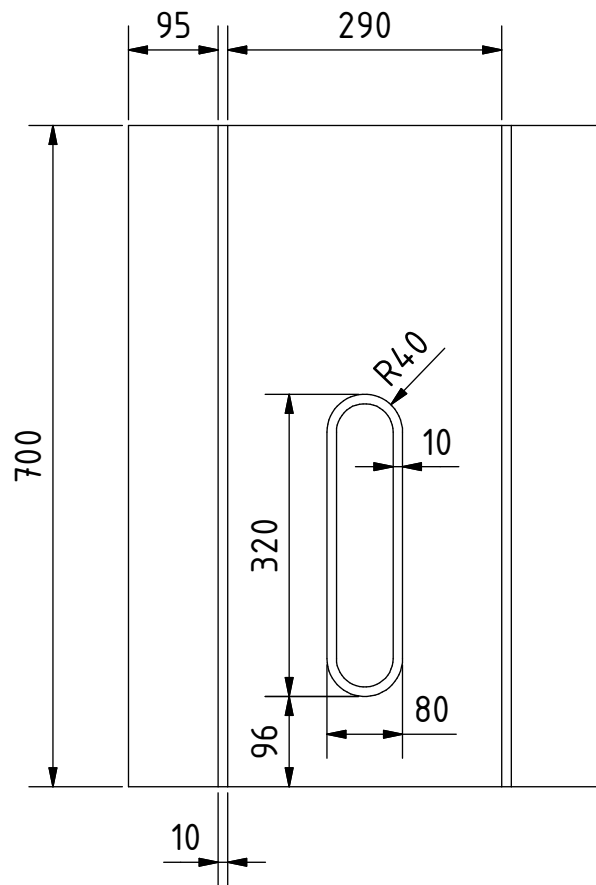

Hinweis: Alle einheiten in mm.

PROJEKT	ERSTELLT VON	GENEHMIGT VON	DATE	VERSION
Tischkreissaege	J. Zeron	A. Morillo	14/08/2021	1.0
TEIL-NAME	DATEI-NAME			TEIL-CODE
Splitter	Splitter.ipt			4.1
UMGESTALTET VON	DOK. TYP	WERKSTOFF	MENGE	
 <b>OPEN HARDWARE OBSERVATORY</b> Free Blueprints for Sustainable Development	Part	Aluminium	1	
	LIZENZ	SCALE	SEITE	
OHO e.V.	CC-BY-SA 4.0	1:8	18 /37	

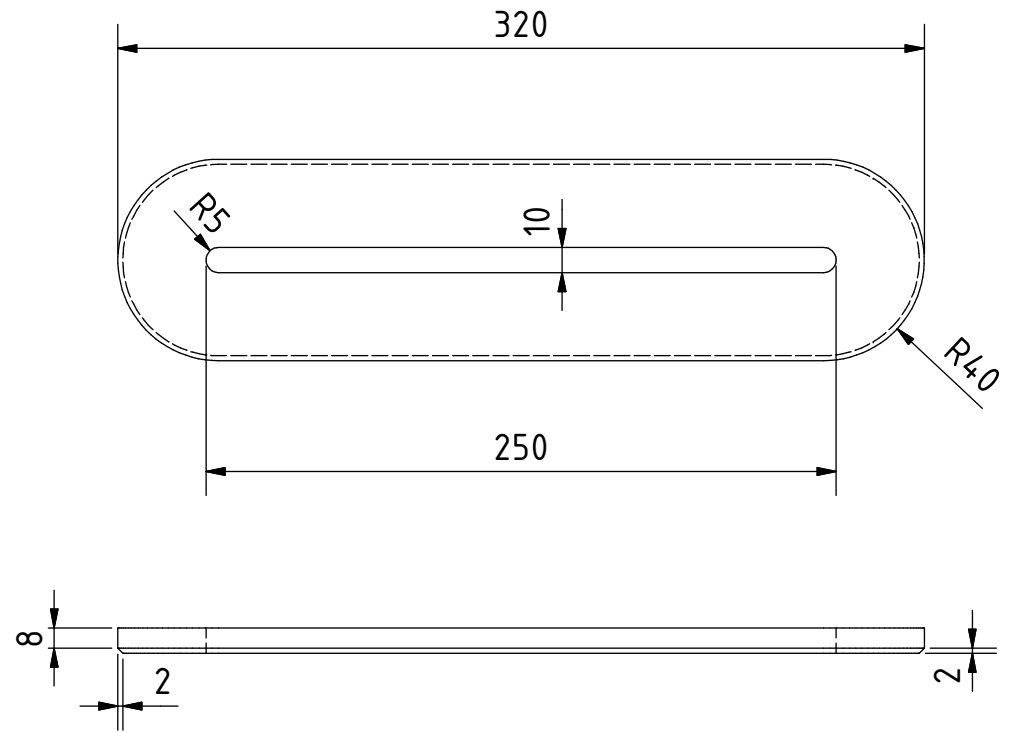
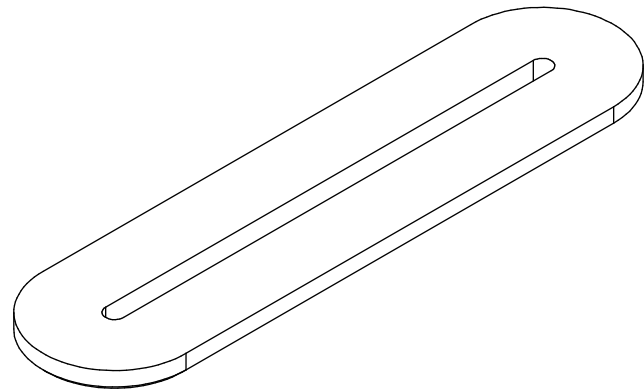

Hinweis: Alle einheiten in mm.

PROJEKT	ERSTELLT VON	GENEHMIGT VON	DATE	VERSION
Tischkreissaege	J. Zeron	A. Morillo	14/08/2021	1.0
TEIL-NAME	DATEI-NAME			TEIL-CODE
Scheibenkappe	Disc cap.ipt			4.2
UMGESTALTET VON	DOK. TYP	WERKSTOFF	MENGE	
 <b>OPEN HARDWARE OBSERVATORY</b> Free Blueprints for Sustainable Development	Part	Aluminium	1	
	LIZENZ	SCALE	SEITE	
OHO e.V.	CC-BY-SA 4.0	1:3	19 /37	

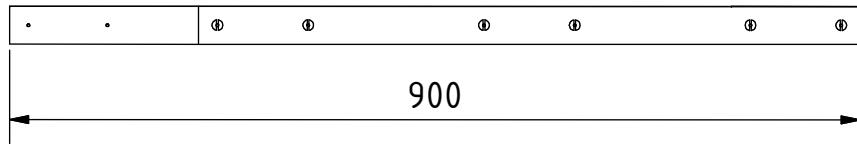
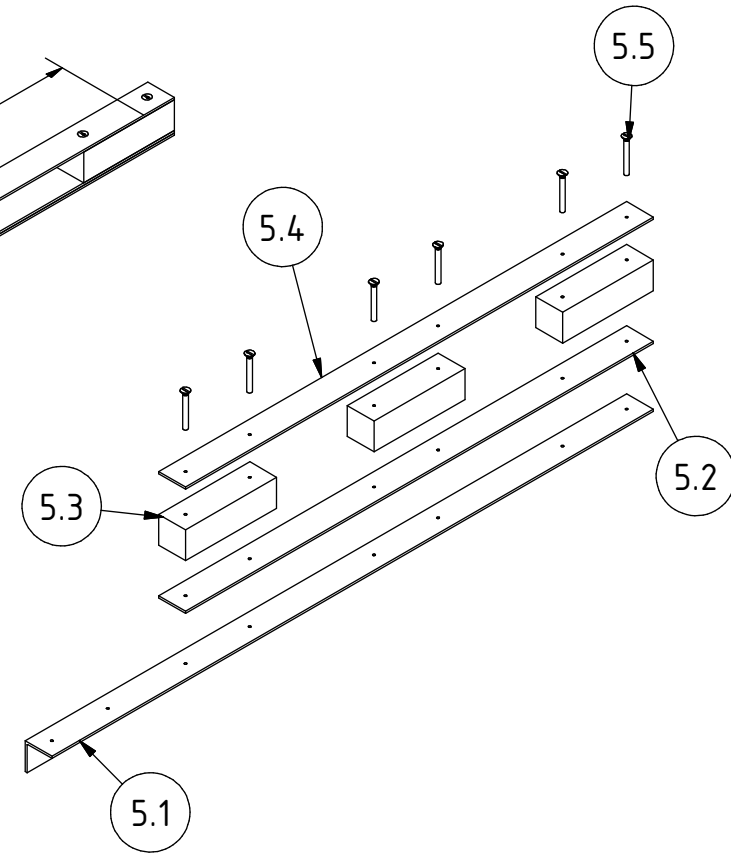
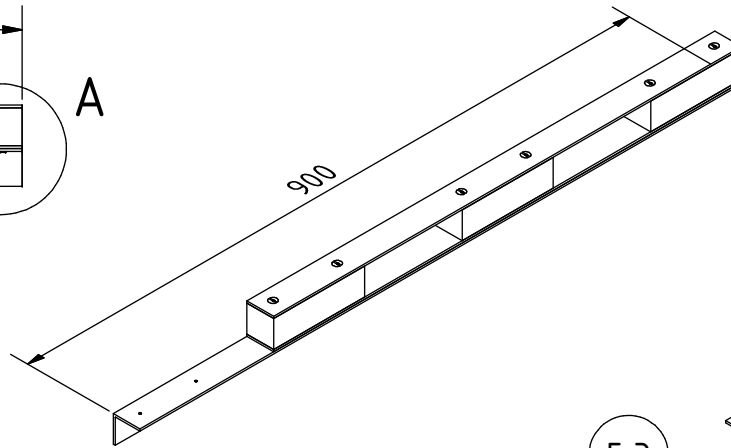
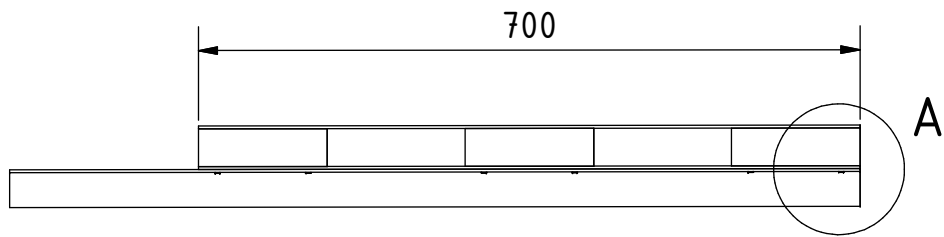

A ( 1 : 3 )

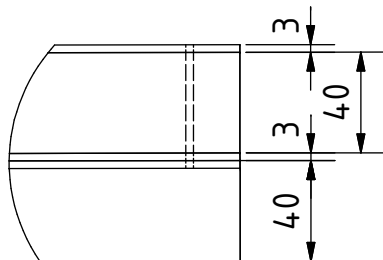

Hinweis: Alle einheiten in mm.

PROJEKT	ERSTELLT VON	GENEHMIGT VON	DATE	VERSION
Tischkreissaege	J. Zeron	A. Morillo	14/08/2021	1.0
TEIL-NAME	DATEI-NAME			TEIL-CODE
Montageleiste	Mounting bar.ipn			5.0
UMGESTALTET VON	DOK. TYP	WERKSTOFF	MENGE	
 <b>OPEN HARDWARE OBSERVATORY</b> Free Blueprints for Sustainable Development	Assembly			
	LIZENZ	SCALE	SEITE	
OHO e.V.	CC-BY-SA 4.0	1:8	20 /37	

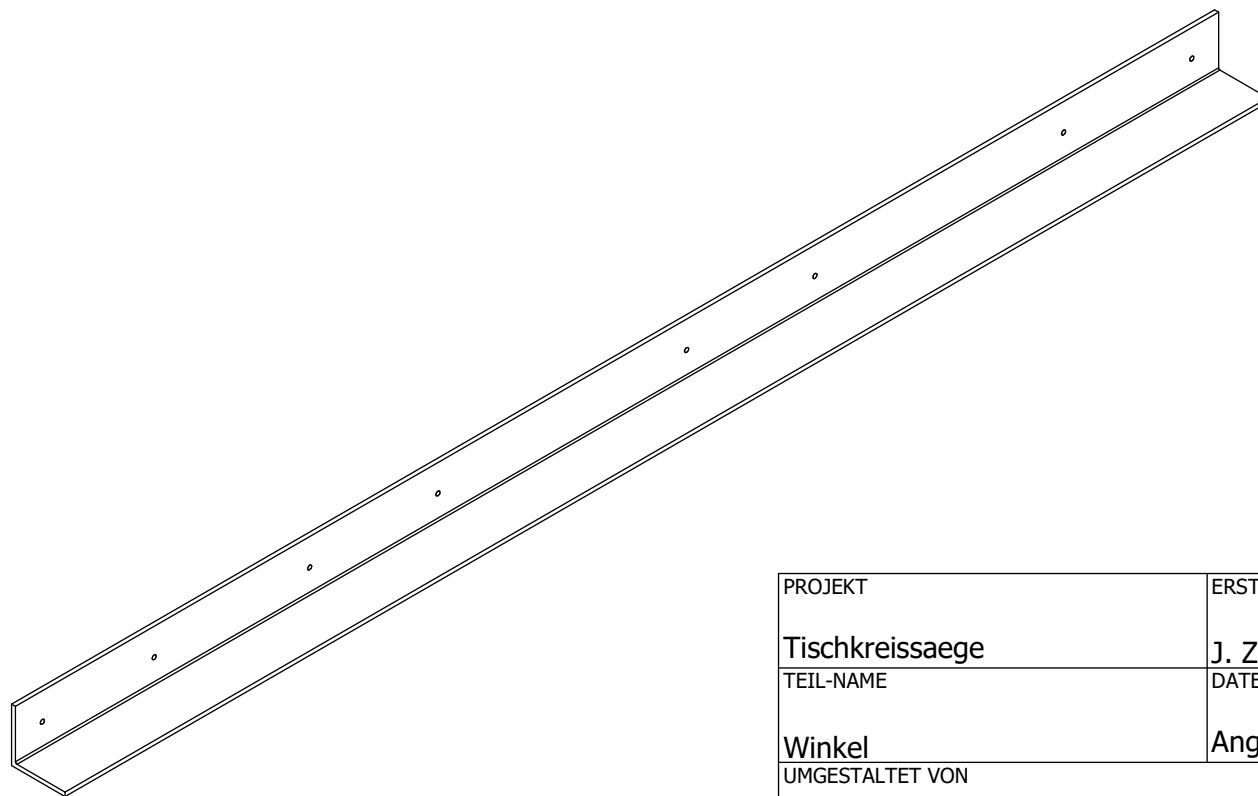
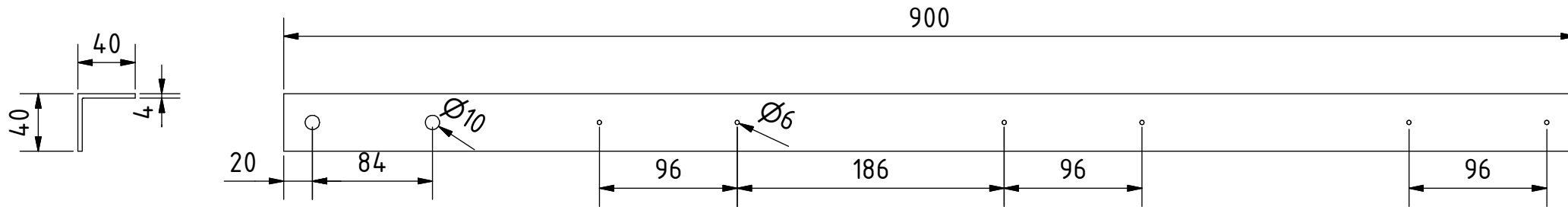

Hinweis: Alle einheiten in mm.

PROJEKT	ERSTELLT VON	GENEHMIGT VON	DATE	VERSION
Tischkreissäge	J. Zeron	A. Morillo	14/08/2021	1.0
TEIL-NAME	DATEI-NAME			TEIL-CODE
Winkel	Angle.ipt			5.1
UMGESTALTET VON	DOK. TYP	WERKSTOFF	MENGE	
 <b>OPEN HARDWARE OBSERVATORY</b> Free Blueprints for Sustainable Development	Part	Stahl A36	2	
	LIZENZ	SCALE	SEITE	
OHO e.V.	CC-BY-SA 4.0	1:4	21 /37	

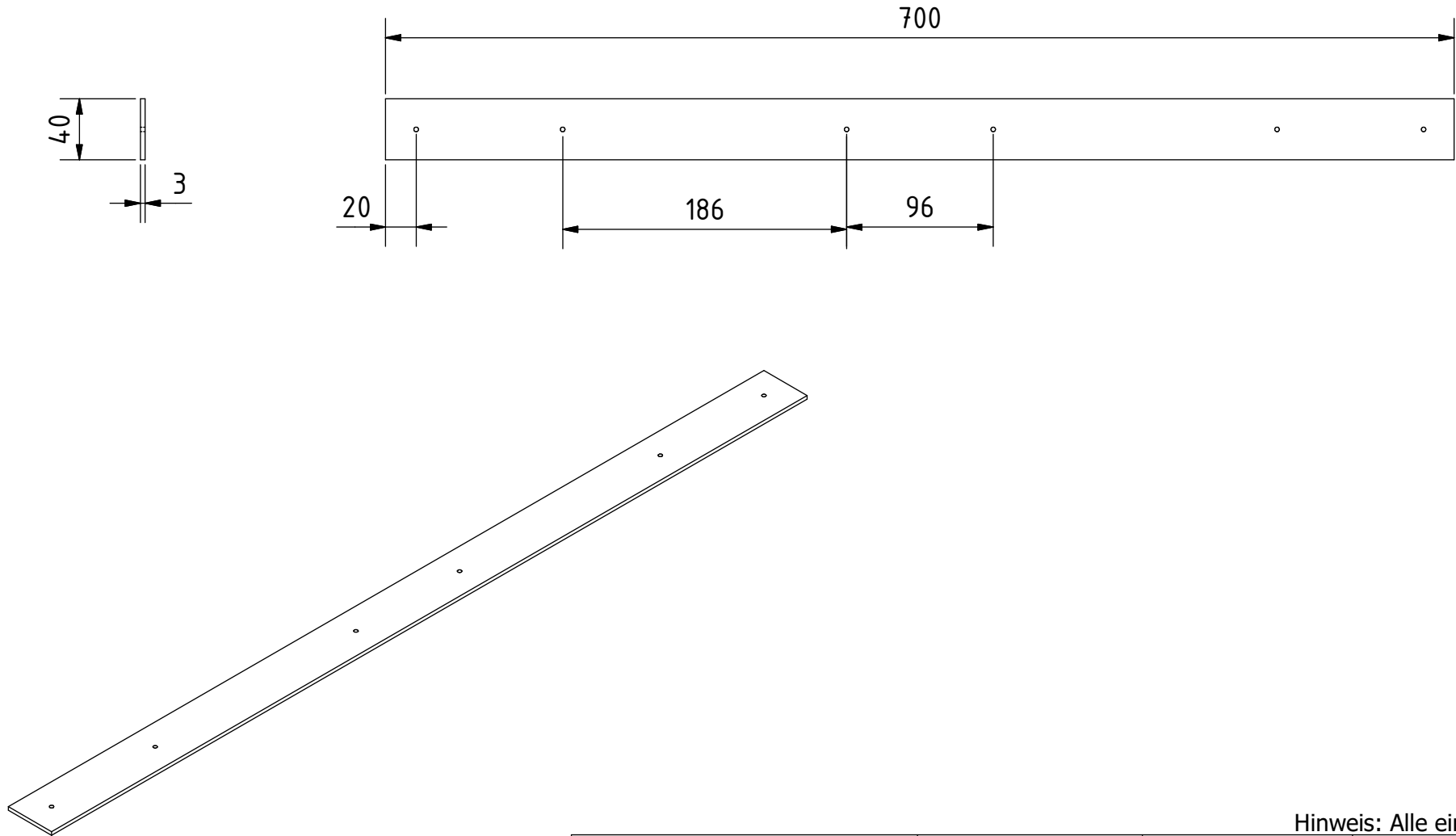

Hinweis: Alle einheiten in mm.

PROJEKT	ERSTELLT VON	GENEHMIGT VON	DATE	VERSION
Tischkreissaege	J. Zeron	A. Morillo	14/08/2021	1.0
TEIL-NAME	DATEI-NAME			TEIL-CODE
Distanzblock	Spacer block.ipt			5.2
UMGESTALTET VON	DOK. TYP	WERKSTOFF	MENGE	
 <b>OPEN HARDWARE OBSERVATORY</b> Free Blueprints for Sustainable Development	Part	Hartholz	2	
	LIZENZ	SCALE	SEITE	
OHO e.V.	CC-BY-SA 4.0	1:4	22 /37	

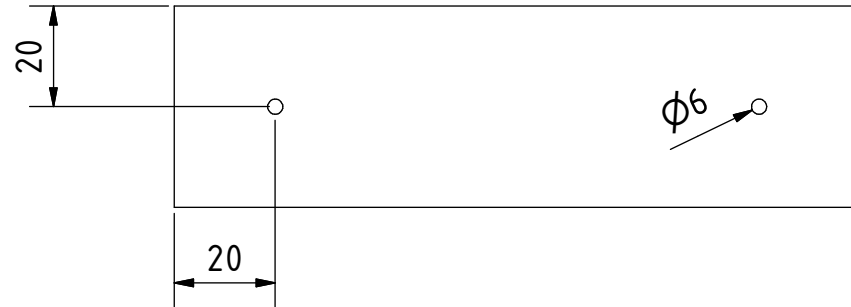
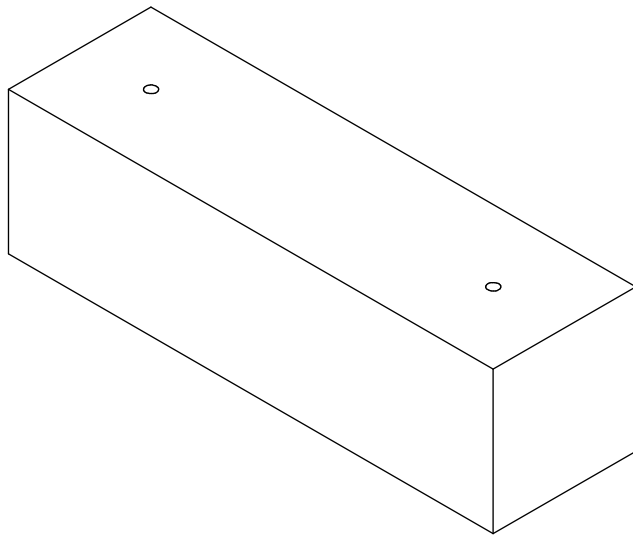
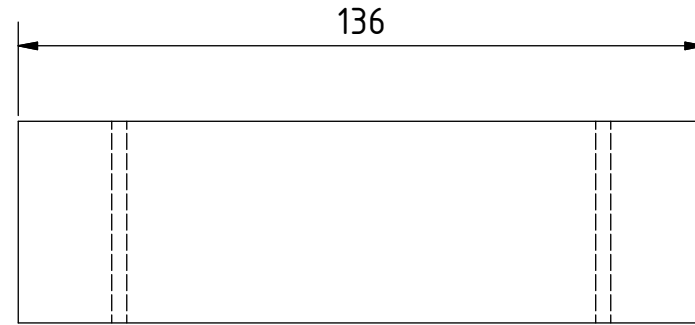
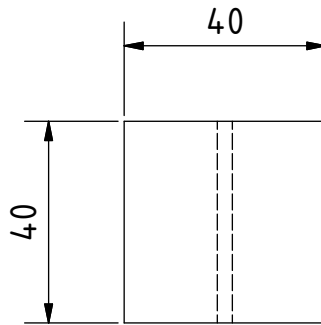

Hinweis: Alle einheiten in mm.

PROJEKT	ERSTELLT VON	GENEHMIGT VON	DATE	VERSION
Tischkreissaege	J. Zeron	A. Morillo	14/08/2021	1.0
TEIL-NAME	DATEI-NAME			TEIL-CODE
Fullblock	Filler block.ipt			5.3
UMGESTALTET VON	DOK. TYP	WERKSTOFF	MENGE	
 <b>OPEN HARDWARE OBSERVATORY</b> Free Blueprints for Sustainable Development	Part	Hartholz	6	
	LIZENZ	SCALE	SEITE	
OHO e.V.	CC-BY-SA 4.0	1:1.5	23 /37	

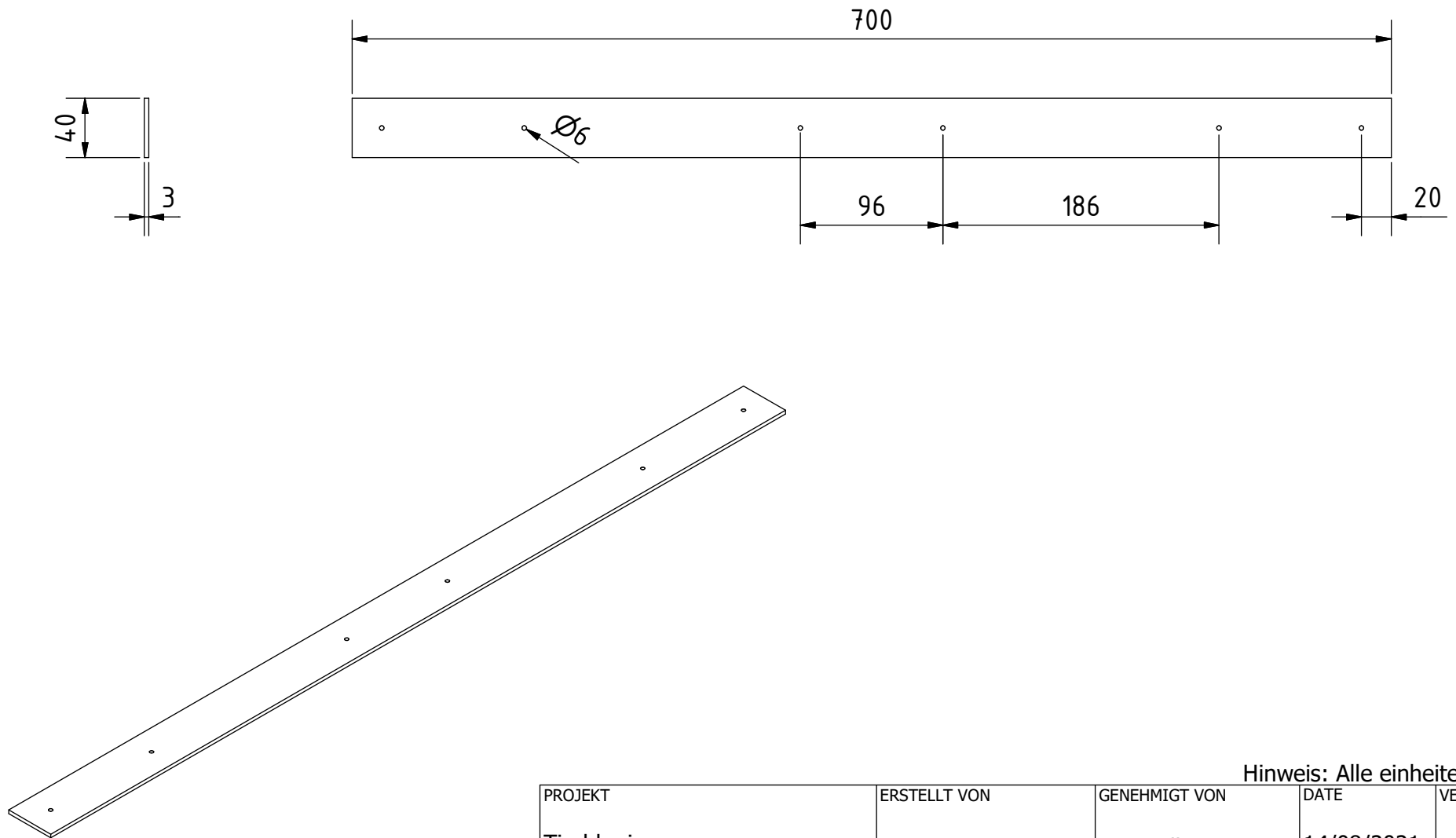

Hinweis: Alle einheiten in mm.

PROJEKT	ERSTELLT VON	GENEHMIGT VON	DATE	VERSION
Tischkreissaege	J. Zeron	A. Morillo	14/08/2021	1.0
TEIL-NAME	DATEI-NAME			TEIL-CODE
Platte	Plate.ipt			5.4
UMGESTALTET VON	DOK. TYP	WERKSTOFF	MENGE	
 <b>OPEN HARDWARE OBSERVATORY</b> Free Blueprints for Sustainable Development	Part	Stahl A36	2	
	LIZENZ	SCALE	SEITE	
OHO e.V.	CC-BY-SA 4.0	1:4	24 /37	



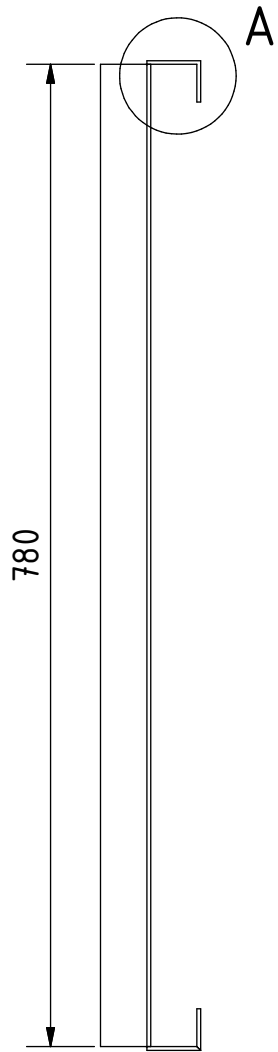

A ( 1 : 3 )

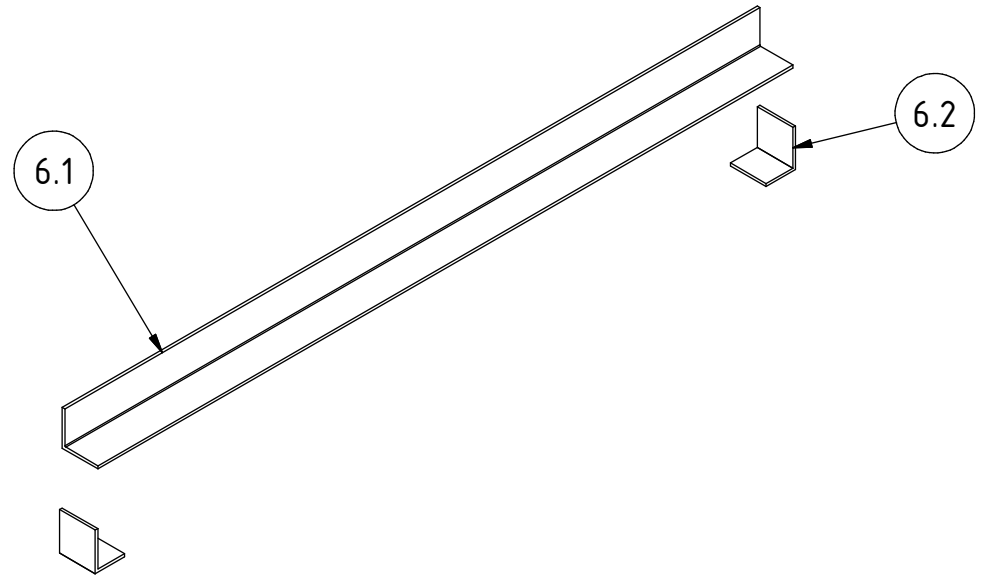
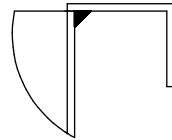

Hinweis: Alle einheiten in mm.

PROJEKT	ERSTELLT VON	GENEHMIGT VON	DATE	VERSION
Tischkreissaege	J. Zeron	A. Morillo	14/08/2021	1.0
TEIL-NAME	DATEI-NAME			TEIL-CODE
Zaun	Fence.ipn			6.0
UMGESTALTET VON	DOK. TYP	WERKSTOFF	MENGE	
 <b>OPEN HARDWARE OBSERVATORY</b> Free Blueprints for Sustainable Development	Assembly			
	LIZENZ	SCALE	SEITE	
OHO e.V.	CC-BY-SA 4.0	1:6	25 /37	

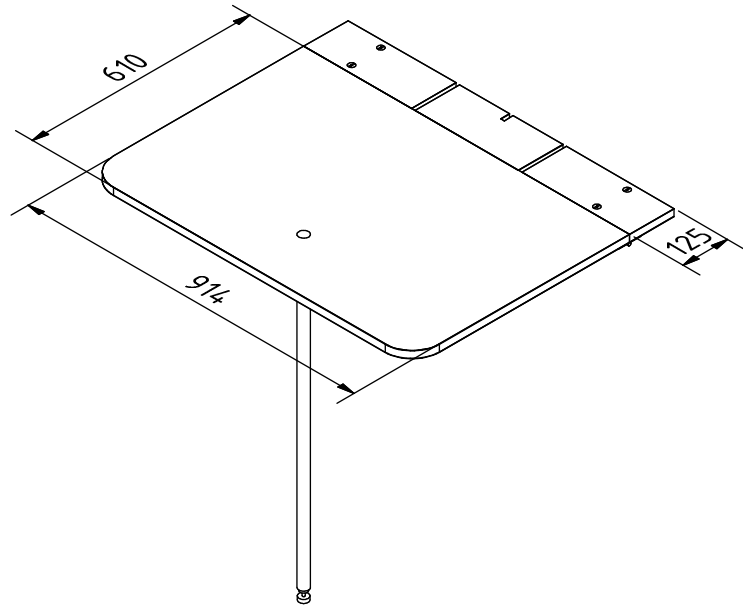
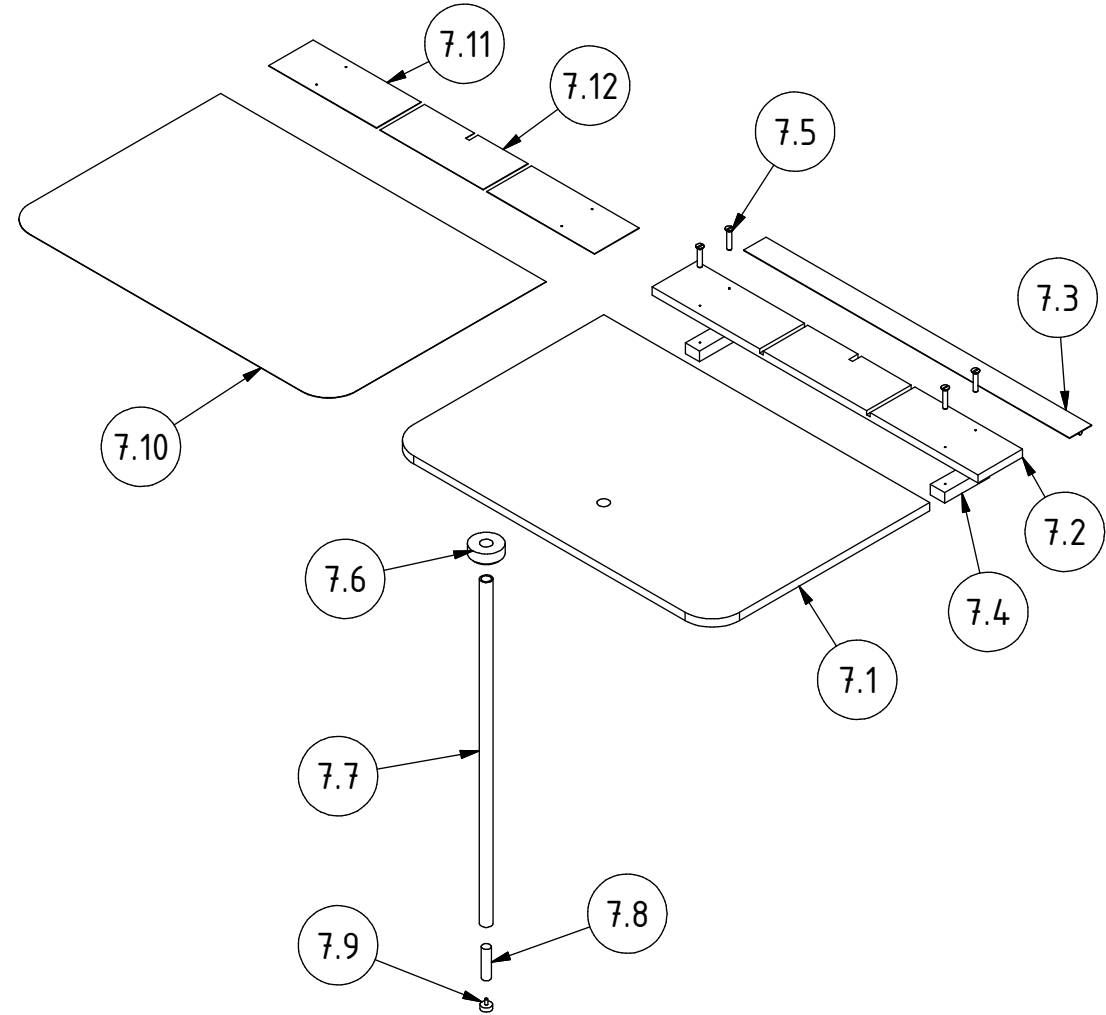
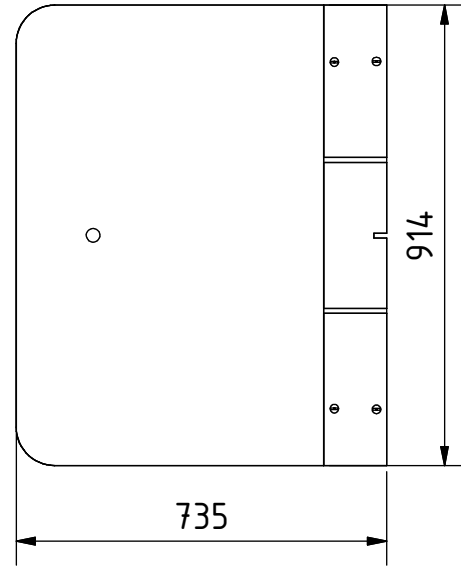
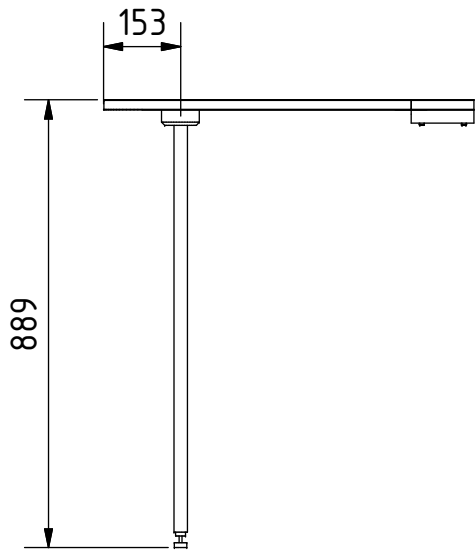

Hinweis: Alle einheiten in mm.

PROJEKT	ERSTELLT VON	GENEHMIGT VON	DATE	VERSION
Tischkreissaege	J. Zeron	A. Morillo	14/08/2021	1.0
TEIL-NAME	DATEI-NAME			TEIL-CODE
Erweiterungstisch	Extension table.ipn			7.0
UMGESTALTET VON	DOK. TYP	WERKSTOFF	MENGE	
 <b>OPEN HARDWARE OBSERVATORY</b> Free Blueprints for Sustainable Development	Assembly			
	LIZENZ	SCALE	SEITE	
OHO e.V.	CC-BY-SA 4.0	1:15	26 /37	

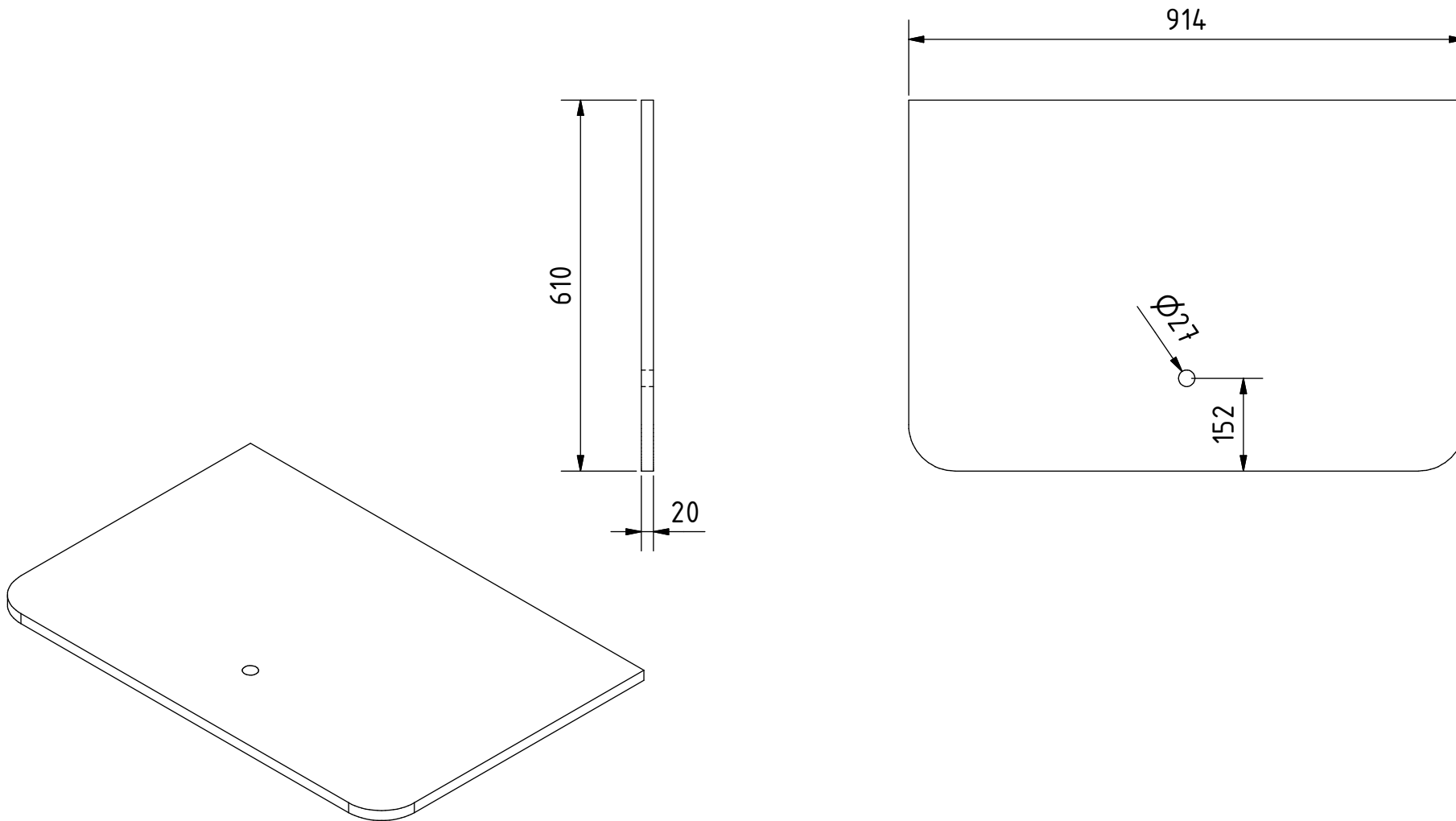

Hinweis: Alle einheiten in mm.

PROJEKT	ERSTELLT VON	GENEHMIGT VON	DATE	VERSION
Tischkreissaege	J. Zeron	A. Morillo	14/08/2021	1.0
TEIL-NAME	DATEI-NAME			TEIL-CODE
Erweiterungstisch	Extension table.ipt			7.1
UMGESTALTET VON	DOK. TYP	WERKSTOFF	MENGE	
 <b>OPEN HARDWARE OBSERVATORY</b> Free Blueprints for Sustainable Development	Part	Sperrholz	1	
	LIZENZ	SCALE	SEITE	
OHO e.V.	CC-BY-SA 4.0	1:10	27 /37	

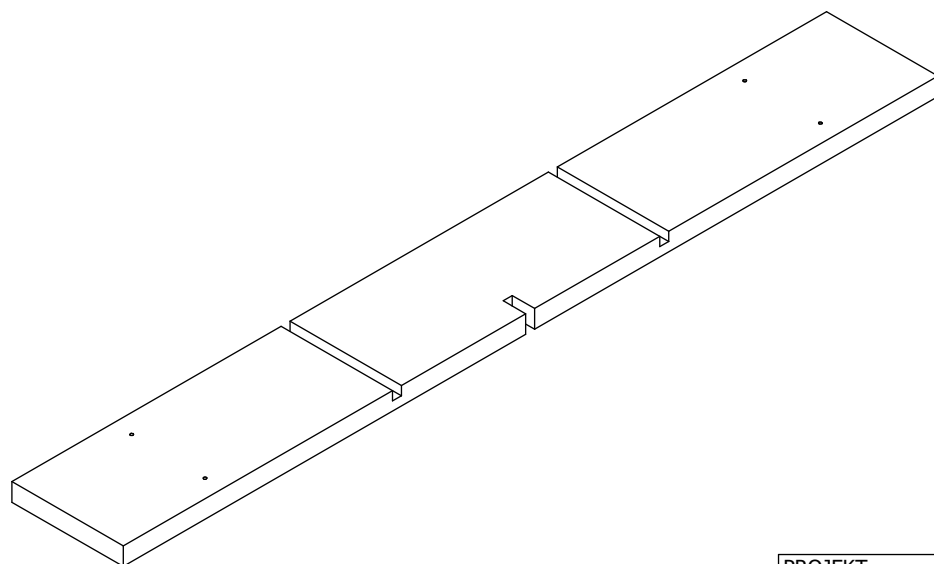
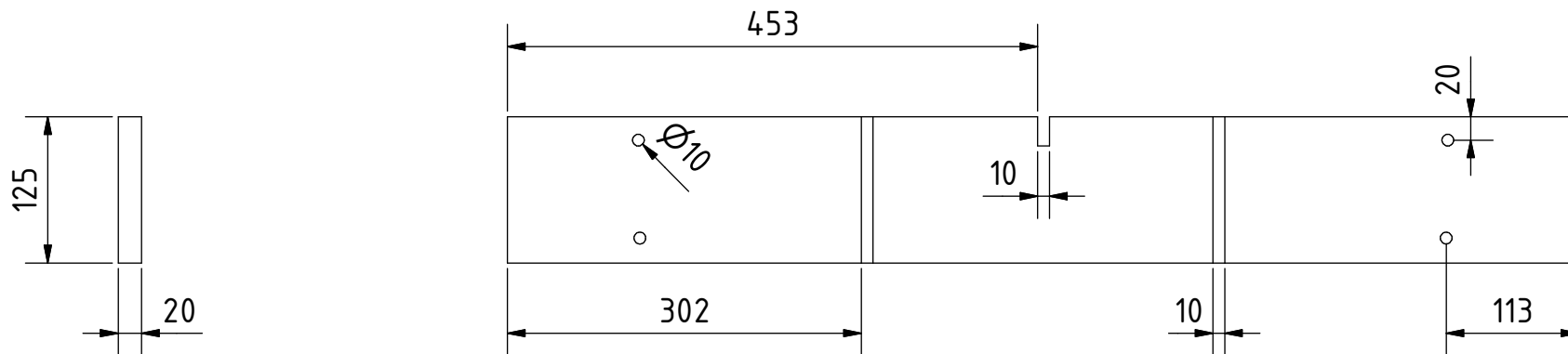

Hinweis: Alle einheiten in mm.

PROJEKT	ERSTELLT VON	GENEHMIGT VON	DATE	VERSION
Tischkreissaege	J. Zeron	A. Morillo	14/08/2021	1.0
TEIL-NAME	DATEI-NAME			TEIL-CODE
Fester tisch	Fixed table.ipt			7.2
UMGESTALTET VON	DOK. TYP	WERKSTOFF	MENGE	
 <b>OPEN HARDWARE OBSERVATORY</b> Free Blueprints for Sustainable Development	Part	Sperrholz	1	
	LIZENZ	SCALE	SEITE	
OHO e.V.	CC-BY-SA 4.0	1:6	28 /37	

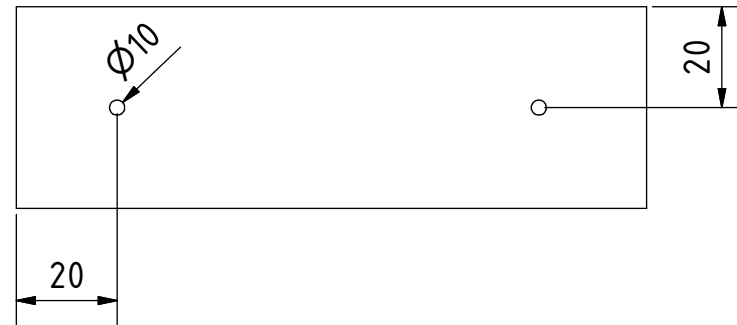
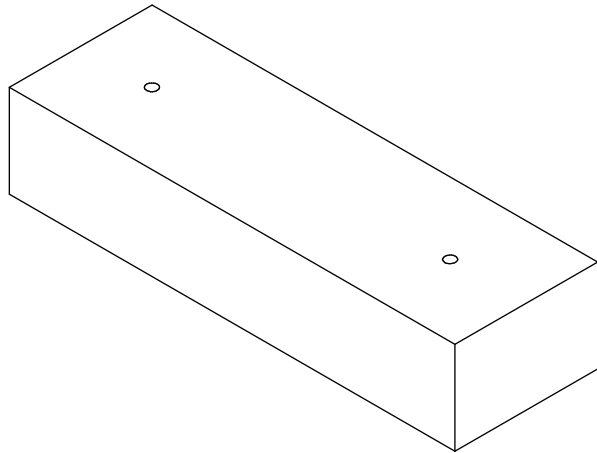
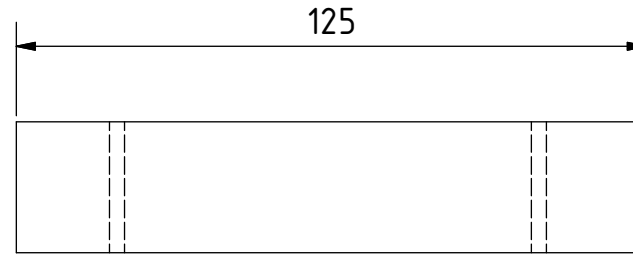
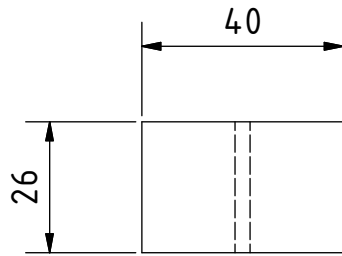

Hinweis: Alle einheiten in mm.

PROJEKT	ERSTELLT VON	GENEHMIGT VON	DATE	VERSION
Tischkreissaege	J. Zeron	A. Morillo	14/08/2021	1.0
TEIL-NAME	DATEI-NAME			TEIL-CODE
Montageblock	Mounting block.ipt			7.4
UMGESTALTET VON	DOK. TYP	WERKSTOFF	MENGE	
 <b>OPEN HARDWARE OBSERVATORY</b> Free Blueprints for Sustainable Development	Part	Hartholz	2	
	LIZENZ	SCALE	SEITE	
OHO e.V.	CC-BY-SA 4.0	1:1.5	29 /37	

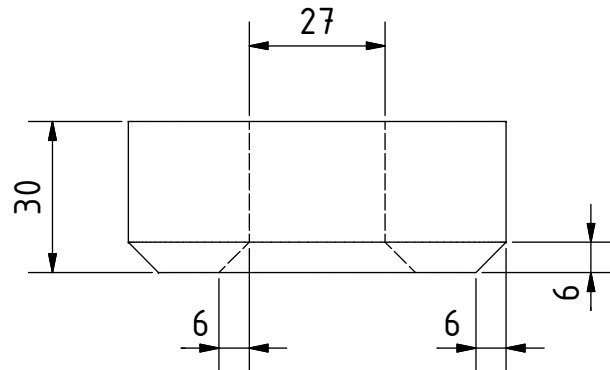
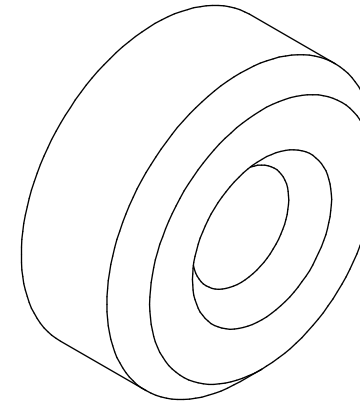
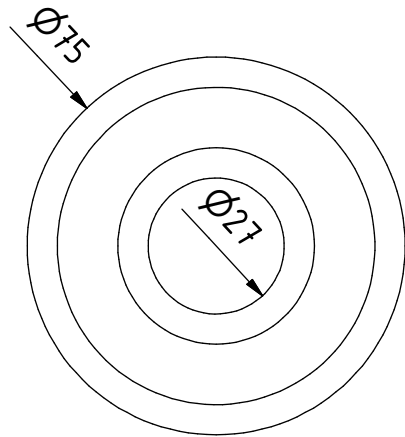

Hinweis: Alle einheiten in mm.

PROJEKT	ERSTELLT VON	GENEHMIGT VON	DATE	VERSION
Tischkreissaege	J. Zeron	A. Morillo	14/08/2021	1.0
TEIL-NAME	DATEI-NAME			TEIL-CODE
Beinfuehrung	Leg guide.ipt			7.6
UMGESTALTET VON	DOK. TYP	WERKSTOFF	MENGE	
 <b>OPEN HARDWARE OBSERVATORY</b> Free Blueprints for Sustainable Development	Part	Hartholz	1	
	LIZENZ	SCALE	SEITE	
OHO e.V.	CC-BY-SA 4.0	1:1.5	30 /37	

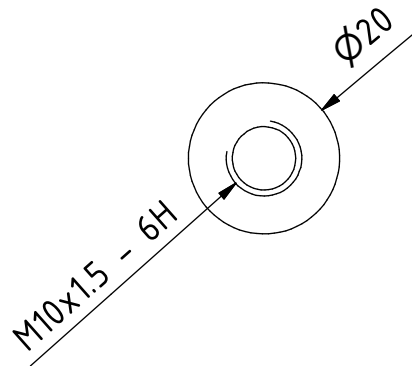
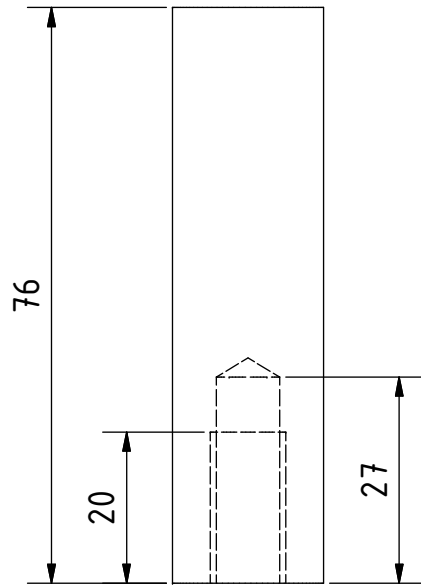

Hinweis: Alle einheiten in mm.

PROJEKT	ERSTELLT VON	GENEHMIGT VON	DATE	VERSION
Tischkreissaege	J. Zeron	A. Morillo	14/08/2021	1.0
TEIL-NAME	DATEI-NAME			TEIL-CODE
Adapter	Adapter.ipt			7.8
UMGESTALTET VON	DOK. TYP	WERKSTOFF	MENGE	
 <b>OPEN HARDWARE OBSERVATORY</b> Free Blueprints for Sustainable Development	Part	Stahl C45	1	
	LIZENZ	SCALE	SEITE	
OHO e.V.	CC-BY-SA 4.0	1:1	31 /37	

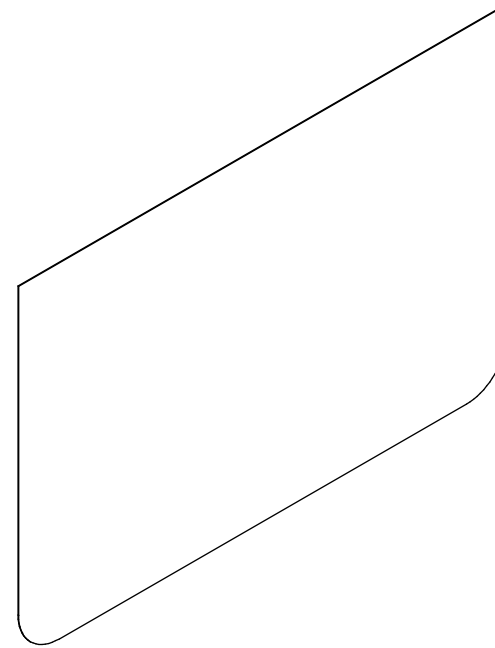
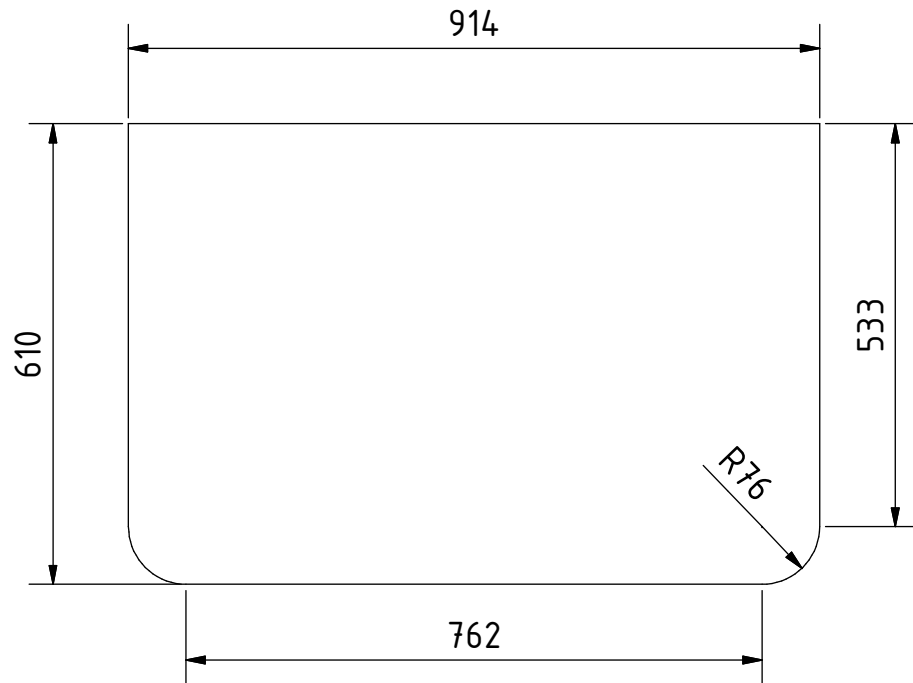

Hinweis: Alle einheiten in mm.

PROJEKT	ERSTELLT VON	GENEHMIGT VON	DATE	VERSION
Tischkreissaege	J. Zeron	A. Morillo	14/08/2021	1.0
TEIL-NAME	DATEI-NAME			TEIL-CODE
Laminat C	Laminate C.ipt			7.10
UMGESTALTET VON	DOK. TYP	WERKSTOFF	MENGE	
 <b>OPEN HARDWARE OBSERVATORY</b> Free Blueprints for Sustainable Development	Part	Kunststofflaminat	2	
	LIZENZ	SCALE	SEITE	
OHO e.V.	CC-BY-SA 4.0	1:10	32 /37	



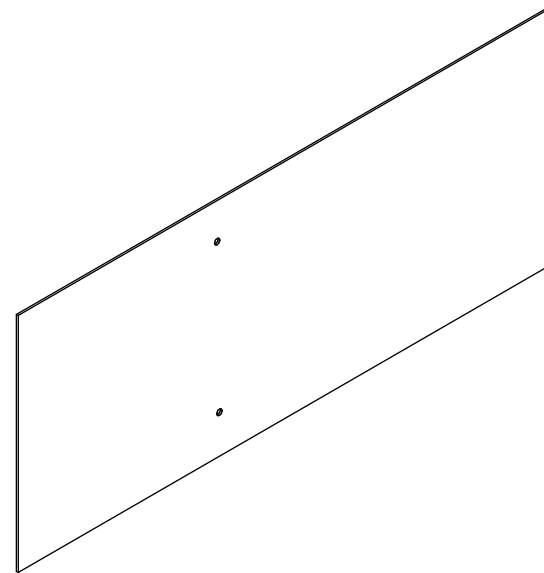
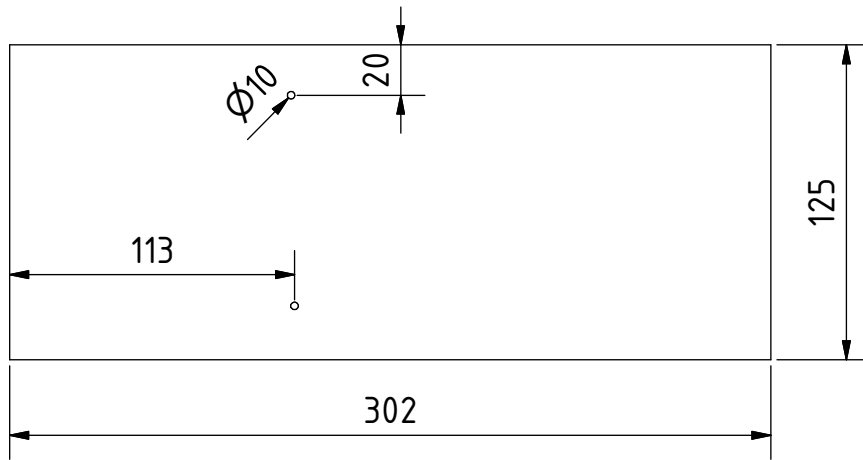

Hinweis: Alle einheiten in mm.

PROJEKT	ERSTELLT VON	GENEHMIGT VON	DATE	VERSION
Tischkreissaege	J. Zeron	A. Morillo	14/08/2021	1.0
TEIL-NAME	DATEI-NAME			TEIL-CODE
Laminat D	Lamine D.ipt			7.11
UMGESTALTET VON	DOK. TYP	WERKSTOFF	MENGE	
 <b>OPEN HARDWARE OBSERVATORY</b> Free Blueprints for Sustainable Development	Part	Kunststofflaminat	4	
	LIZENZ	SCALE	SEITE	
OHO e.V.	CC-BY-SA 4.0	1:3	33 /37	

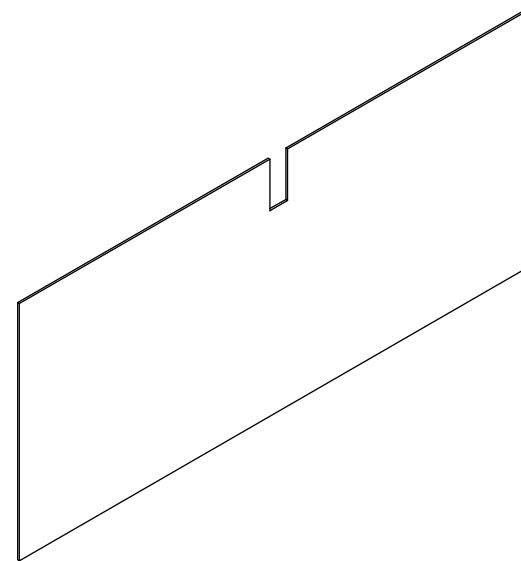
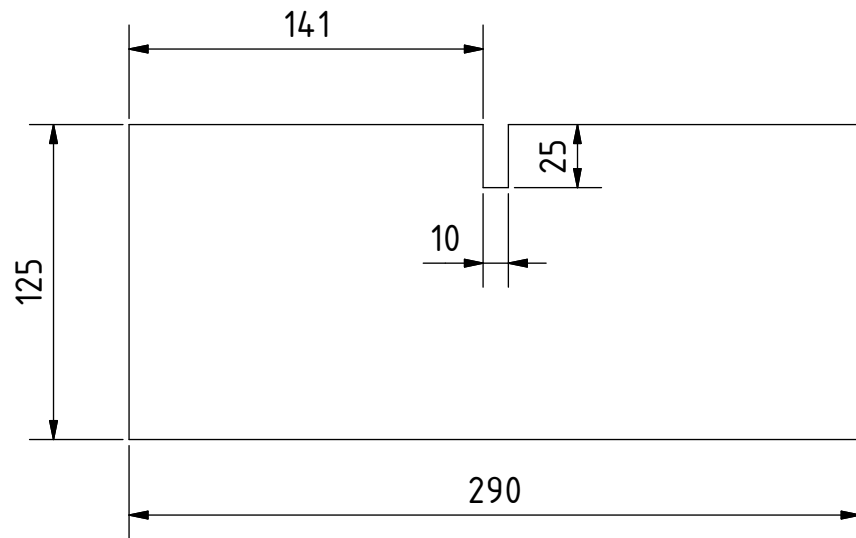

Hinweis: Alle einheiten in mm.

PROJEKT	ERSTELLT VON	GENEHMIGT VON	DATE	VERSION
Tischkreissaege	J. Zeron	A. Morillo	14/08/2021	1.0
TEIL-NAME	DATEI-NAME			TEIL-CODE
Laminat E	Laminate E.ipt			7.12
UMGESTALTET VON	DOK. TYP	WERKSTOFF	MENGE	
 <b>OPEN HARDWARE OBSERVATORY</b> Free Blueprints for Sustainable Development	Part	Kunststofflaminat	2	
	LIZENZ	SCALE	SEITE	
OHO e.V.	CC-BY-SA 4.0	1:3	34 /37	

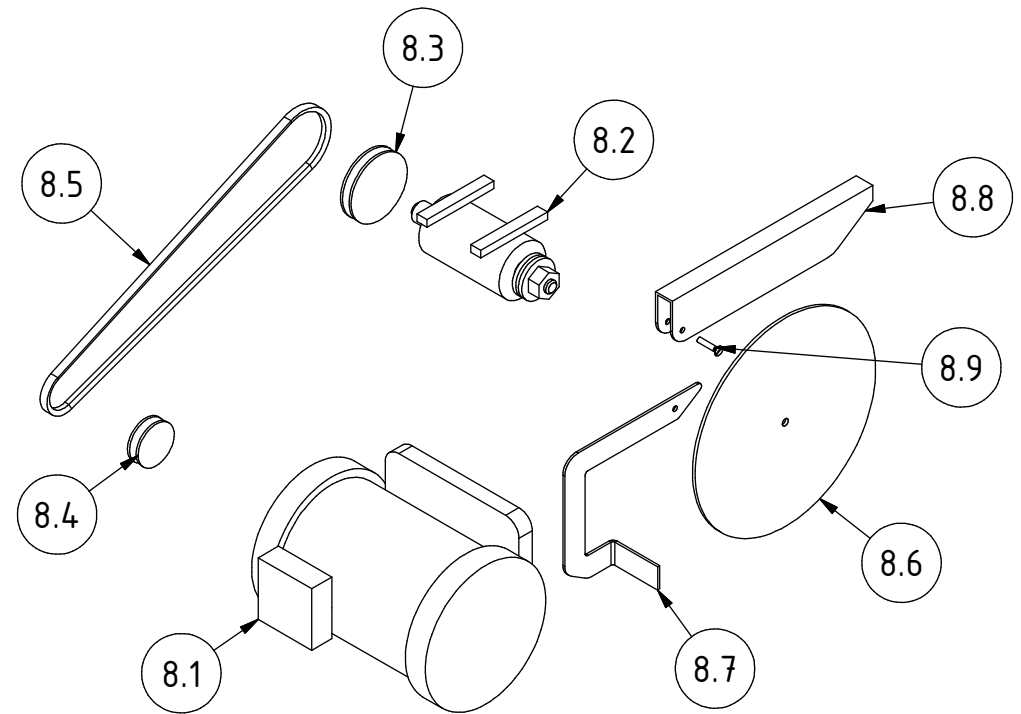
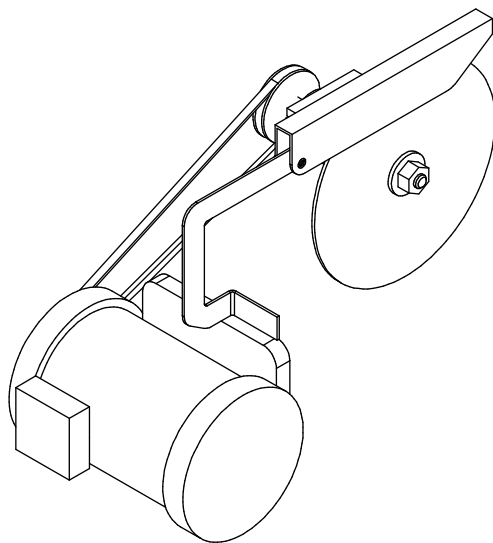
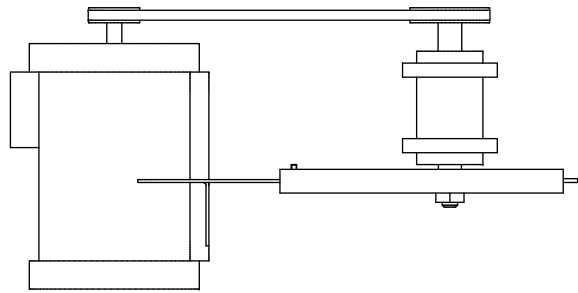
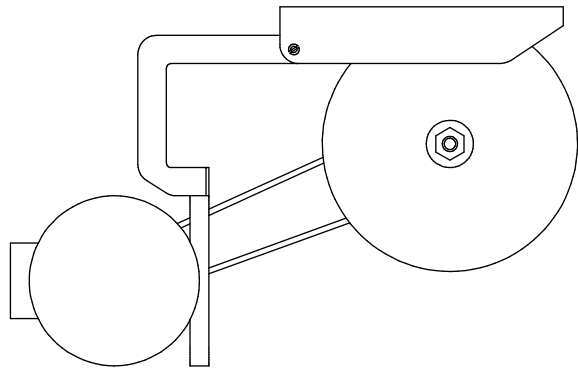

Hinweis: Alle einheiten in mm.

PROJEKT	ERSTELLT VON	GENEHMIGT VON	DATE	VERSION
Tischkreissaege	J. Zeron	A. Morillo	14/08/2021	1.0
TEIL-NAME	DATEI-NAME			TEIL-CODE
Sagekomponenten	Saw components.ipn			8.0
UMGESTALTET VON	DOK. TYP	WERKSTOFF	MENGE	
 <b>OPEN HARDWARE OBSERVATORY</b> Free Blueprints for Sustainable Development	Assembly			
	LIZENZ	SCALE	SEITE	
OHO e.V.	CC-BY-SA 4.0	1:8	35 /37	

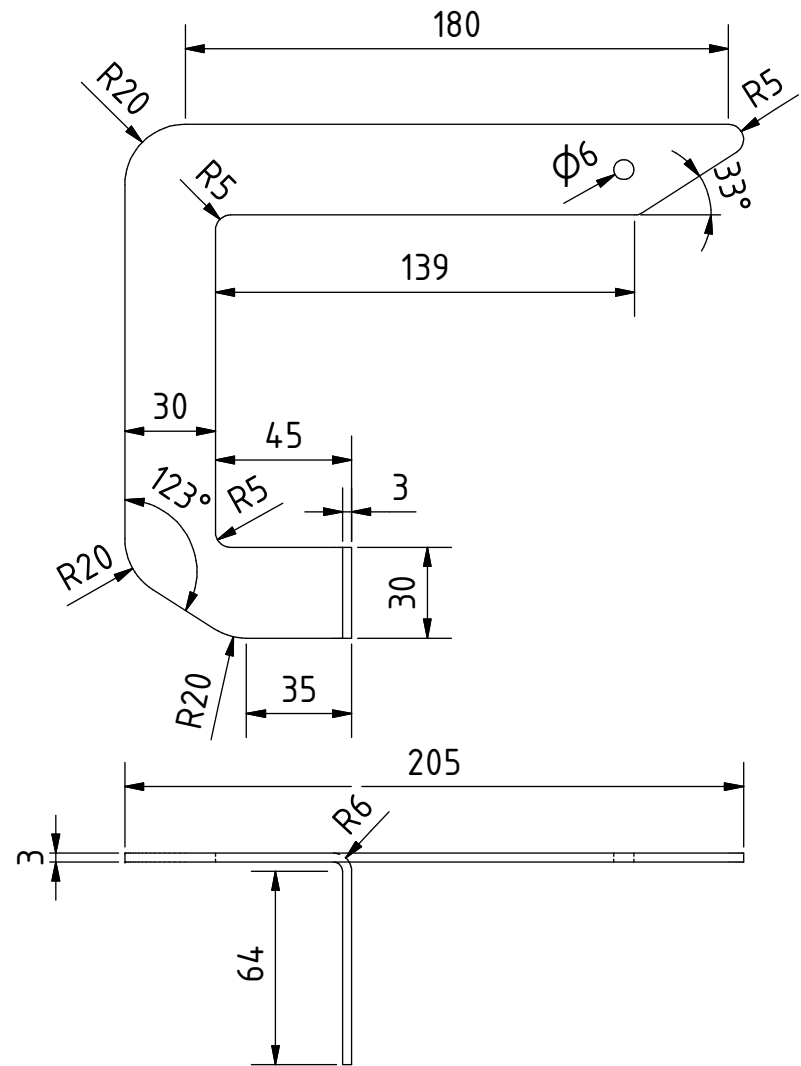
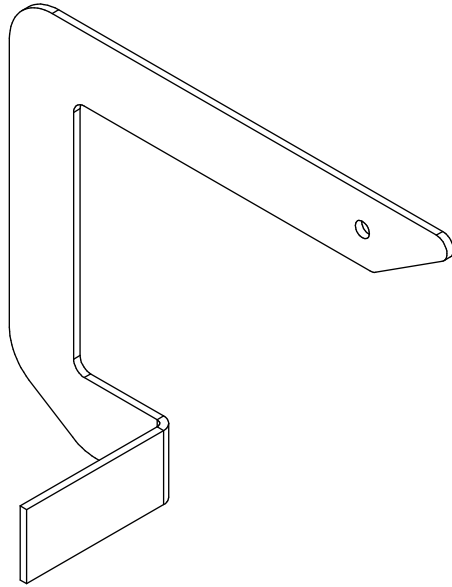

Hinweis: Alle einheiten in mm.

PROJEKT	ERSTELLT VON	GENEHMIGT VON	DATE	VERSION
Tischkreissaege	J. Zeron	A. Morillo	14/08/2021	1.0
TEIL-NAME	DATEI-NAME			TEIL-CODE
Spatmesser	Riving knife.ipt			8.7
UMGESTALTET VON	DOK. TYP	WERKSTOFF	MENGE	
 <b>OPEN HARDWARE OBSERVATORY</b> Free Blueprints for Sustainable Development	Part	Stahl C45	1	
	LIZENZ	SCALE	SEITE	
OHO e.V.	CC-BY-SA 4.0	1:2.5	36 /37	

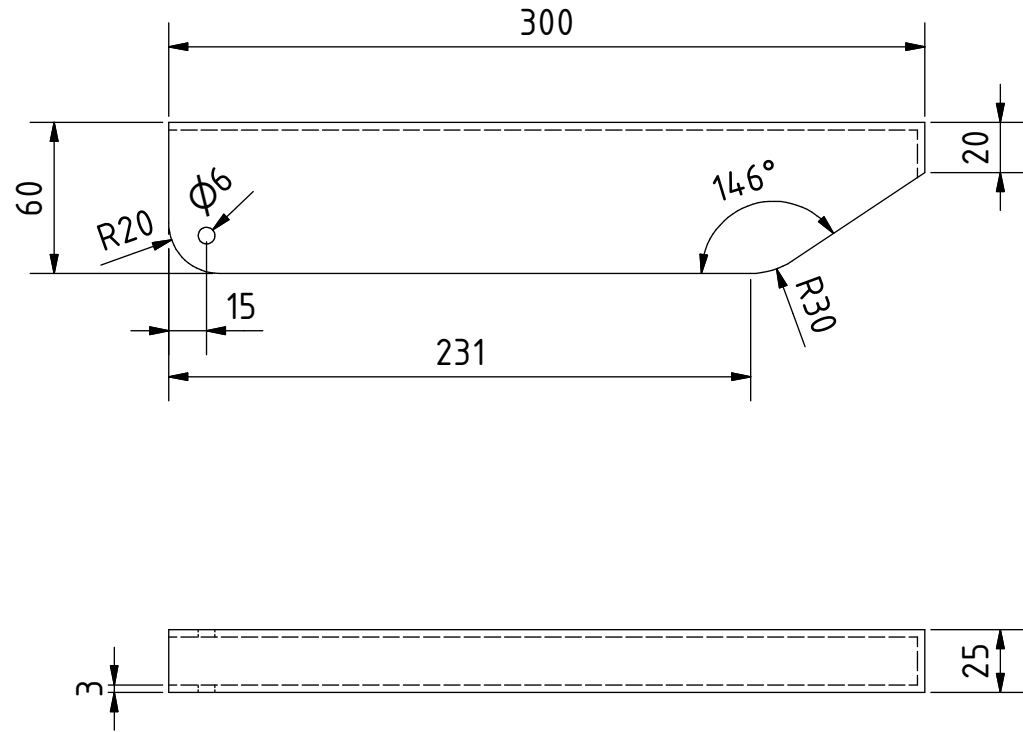
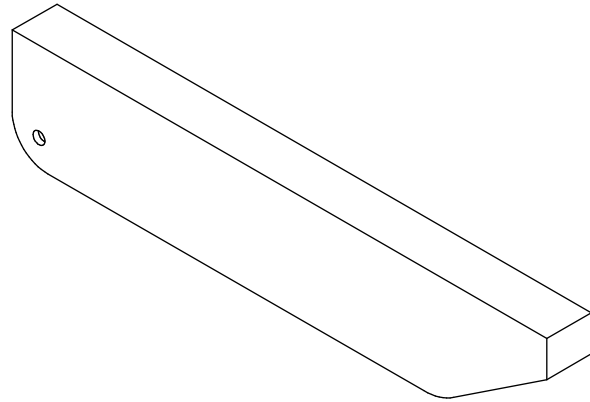

Hinweis: Alle einheiten in mm.

PROJEKT	ERSTELLT VON	GENEHMIGT VON	DATE	VERSION
Tischkreissaege	J. Zeron	A. Morillo	14/08/2021	1.0
TEIL-NAME	DATEI-NAME			TEIL-CODE
Klingenschutz	Blade guard.ipt			8.8
UMGESTALTET VON	DOK. TYP	WERKSTOFF	MENGE	
 <b>OPEN HARDWARE OBSERVATORY</b> Free Blueprints for Sustainable Development	Part	Acetat oder polycarbonat	1	
	LIZENZ	SCALE	SEITE	
OHO e.V.	CC-BY-SA 4.0	1:3	37 /37	