

Note: All units in mm.

PROJECT	CREATED BY	APPROVED BY	DATE	VERSION
Welding gun multifuntional & diy	D. MOSQUERA	A. MORILLO	01/08/2021	1.0
PART NAME	FILE NAME			POS
3d views	oho_wg_A1-welding-gun-multifuntional-and-diy.iam			A1
PUBLISHED BY	DOC. TYPE	MATERIAL	QUANTITY	
 OPEN HARDWARE OBSERVATORY Free Blueprints for Sustainable Development	Assembly		1	
	LICENCE	SCALE	SHEET	
OHO e.V.	CC-BY-SA 4.0	1:1,5	1 /22	

Based on drawings of Phillip M. Wilson

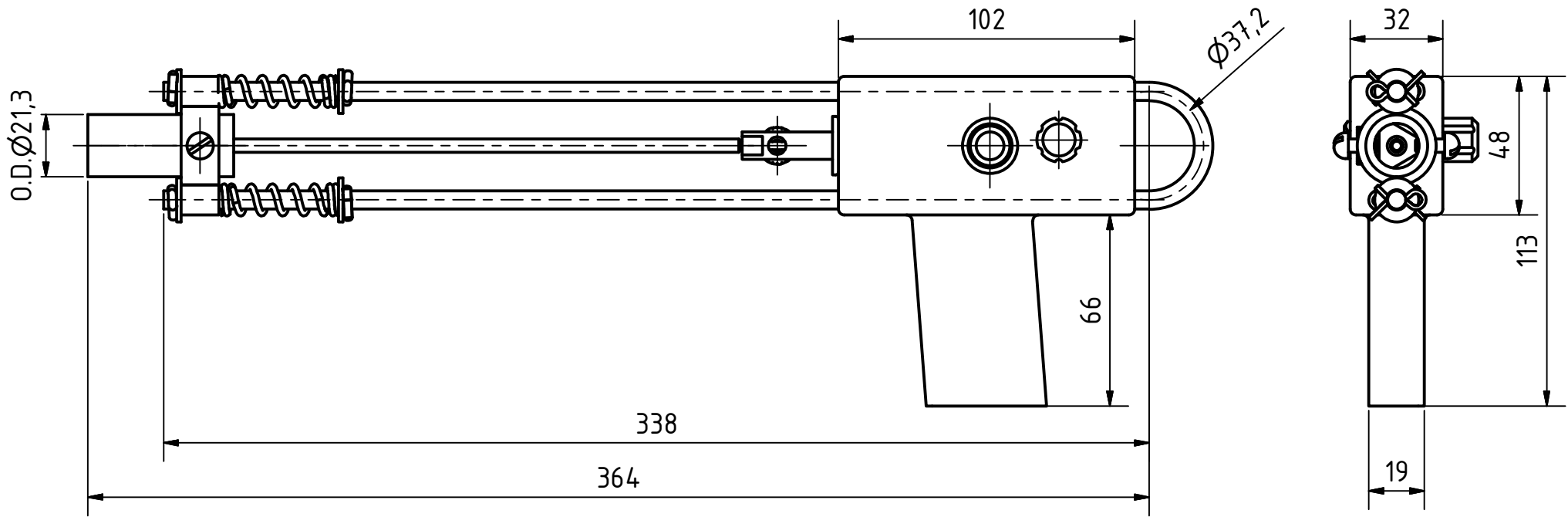

Nozzle flap

Inside corner

Outside corner

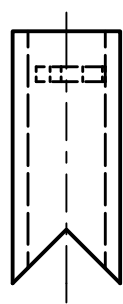
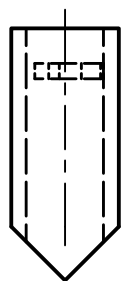
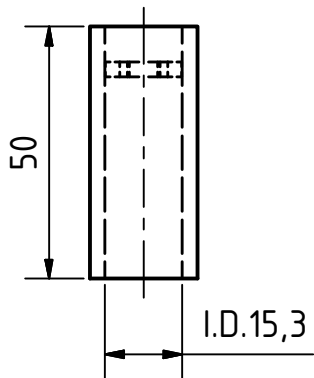

Note: All units in mm.

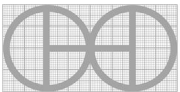
PROJECT	CREATED BY	APPROVED BY	DATE	VERSION
Welding gun multifunctional & diy	D. MOSQUERA	A. MORILLO	01/08/2021	1.0
PART NAME	FILE NAME			POS
3d views	oho_wg_A1-welding-gun-multifunctional-and-diy.iam			A1
PUBLISHED BY	DOC. TYPE	MATERIAL	QUANTITY	
 OPEN HARDWARE OBSERVATORY Free Blueprints for Sustainable Development	Assembly		1	
	LICENCE	SCALE	SHEET	
OHO e.V.	CC-BY-SA 4.0		2 / 22	

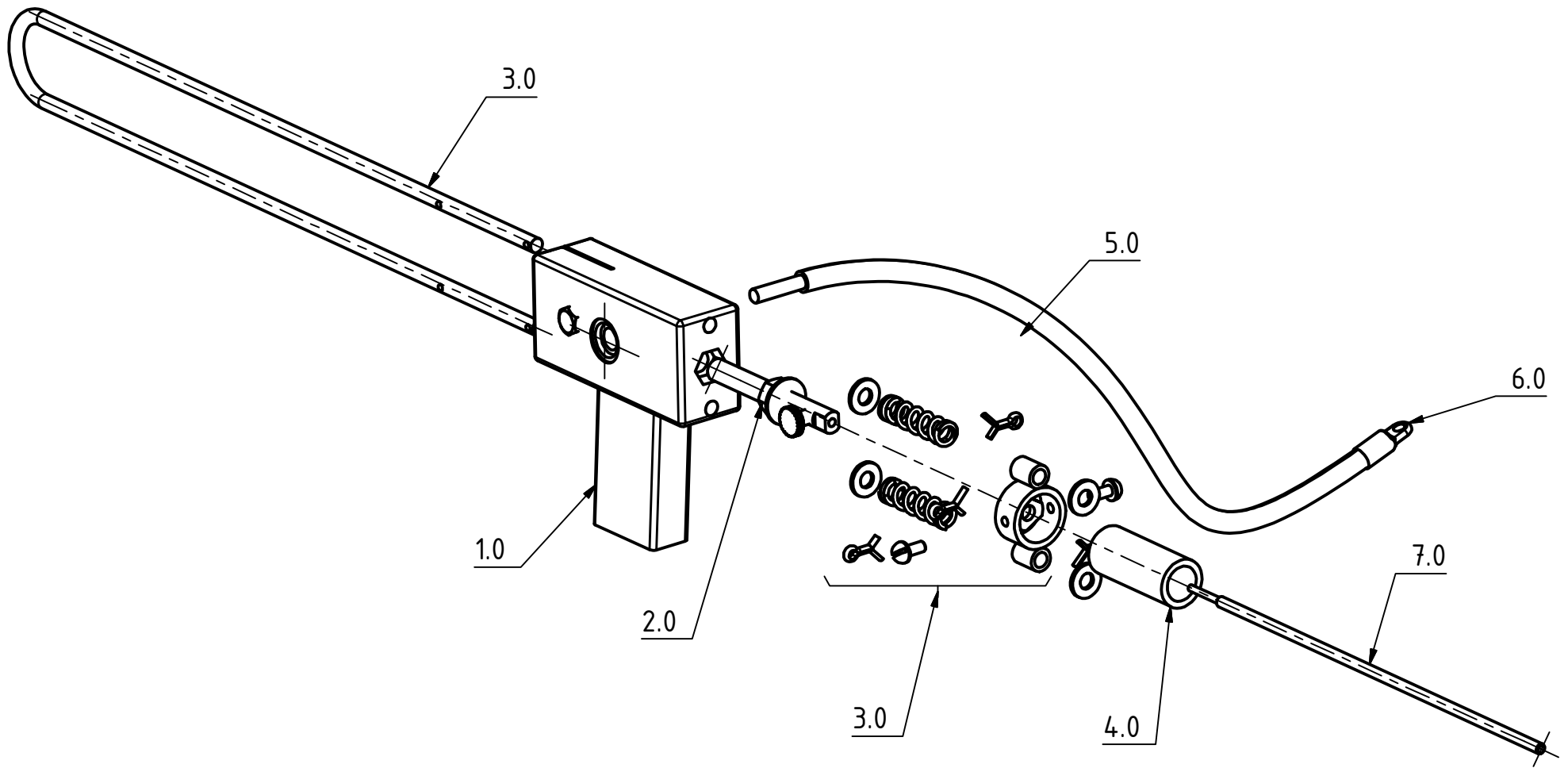

PROJECT	CREATED BY	APPROVED BY	DATE	VERSION
Welding gun multifuntional & diy	D. MOSQUERA	A. MORILLO	01/08/2021	1.0
PART NAME	FILE NAME			POS
Exploded 3d view	oho_wg_A1-welding-gun-multifuntional-and-diy.ipn			A2
PUBLISHED BY	DOC. TYPE	MATERIAL		QUANTITY
 OPEN HARDWARE OBSERVATORY Free Blueprints for Sustainable Development	Assembly			1
	LICENCE	SCALE		SHEET
OHO e.V.	CC-BY-SA 4.0	1:2		3 /22

Parts list

POS	QTY	PART NAME	FILE NAME	PART TYPE	SPECIFICATIONS	SHEET
A1	1	3d views	oho_wg_A1-welding-gun-multifunctional-and-diy.iam			1
A1	1	3d views	oho_wg_A1-welding-gun-multifunctional-and-diy.iam			2
A2	1	Exploded 3d view	oho_wg_A1-welding-gun-multifunctional-and-diy.ipn			3
B1		Parts list	oho_wg_part-list.xls			4
1.0	1	Handle welding	oho_wg_Handle.iam			5
1.0	1	Handle Welding	oho_wg_Handle.ipn			6
1.1	1	Handle	oho_wg_handle.ipt	Production	Wood	7
1.2	1	Knob	oho_wg_knob.ipt	Production	Plastic HD	8
1.3	1	bolt 1/4x45	oho_vsw_bolt-1-4x45.ipt	Standard	bolt 1/4x45, 6.0 mm stud x 32 long	
1.4	1	Fiber sleeve	oho_wg_fiber-sleeve.ipt	Production	Fiber or plastic insulation	9
1.5	1	Copper tube	oho_wg_cooper-tube.ipt	Production	pipe ID.10 - Sch 80, copper	10
2.0	1	Conductor tube	oho_wg_conductor-tube.iam			11
2.0	1	Conductor tube	oho_wg_conductor-tube.ipn			12
2.1	1	Tube	oho_wg_conductor-tube.ipt	Production	copper	13
2.2	1	Bolt M6	oho_wg_bolt-1-4x19.ipt	Production	Bolt modif M6x1.5, Steel C45	14
2.3	1	Tee nut	oho_wg_tee-nut.ipt	Standard	Tee nut, M10 x 1.5	
3.0	1	Brass rod	oho_wg_Brass rod.iam			15
3.0	1	Brass rod	oho_wg_Brass rod.ipn			16
3.1	1	Slide rod	oho_wg_slide-rod.ipt	Production	stainless steel or non corrosive metal, brass, bronze	17
3.2	1	suport	oho_wg_suport.iam	Production	pipe-sch 40 weldier, Steel C45	18
3.3	2	Compress Spring	Compress Spring1.ipt	Standard	Compress Spring, Sprint 11x7x2 Long: 40 - light load	
3.4	4	Washer	oho_wg_Washer-M6.ipt	Standard	Washer , M6 DIN 9021	
3.5	2	bolt	oseg_swt_bolt-M4x10.ipt	Standard	bolt , M5 - round head DIN 7985	
3.6	4	pin	oho_wg_pin.ipt	Standard	pin, pin 5mm Steel C45	
4.0	1	Nozzle holder	oho_wg_nozzle-holder.iam			19
4.0	1	Nozzle holder	oho_wg_nozzle-holder.ipn			20
4.1	1	Nozzle	oho_wg_nozzle-holder.ipt	Production	tube 12 a 16 x 50 long, copper	21
4.2	1	Sheet hole	oho_wg_sheet-hole.ipt	Production	Steel C45	22
5.0	1	Welding cable	oho_wg_welding-cable.ipt	Standard	Welding cable, no.4 rubber-jacket type-3.0m, copper	
6.0	1	Lug#4	oho_wg_lug#4.ipt	Standard	Lug#4, for cable 100-amp lug, copper	

PROJECT	CREATED BY	APPROVED BY	DATE	VERSION
Welding gun multifunctional & diy	D. MOSQUERA	A. MORILLO	01/08/2021	1.0
PART NAME	FILE NAME			POS
Parts list	oho_wg_part-list.xls			B1
PUBLISHED BY	DOC. TYPE	MATERIAL		QUANTITY
 OPEN HARDWARE OBSERVATORY Free Blueprints for Sustainable Development OHO e.V.	Parts list			
	LICENCE	SCALE		SHEET
	CC-BY-SA 4.0			4 / 22

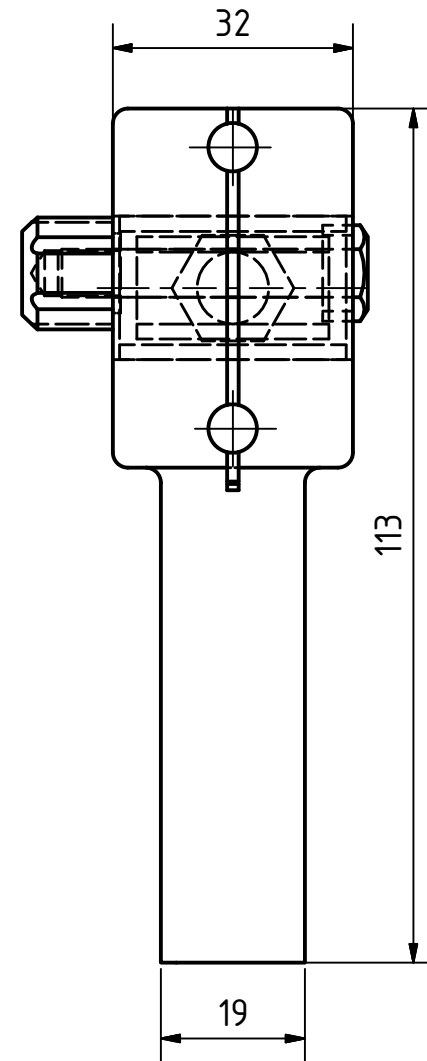
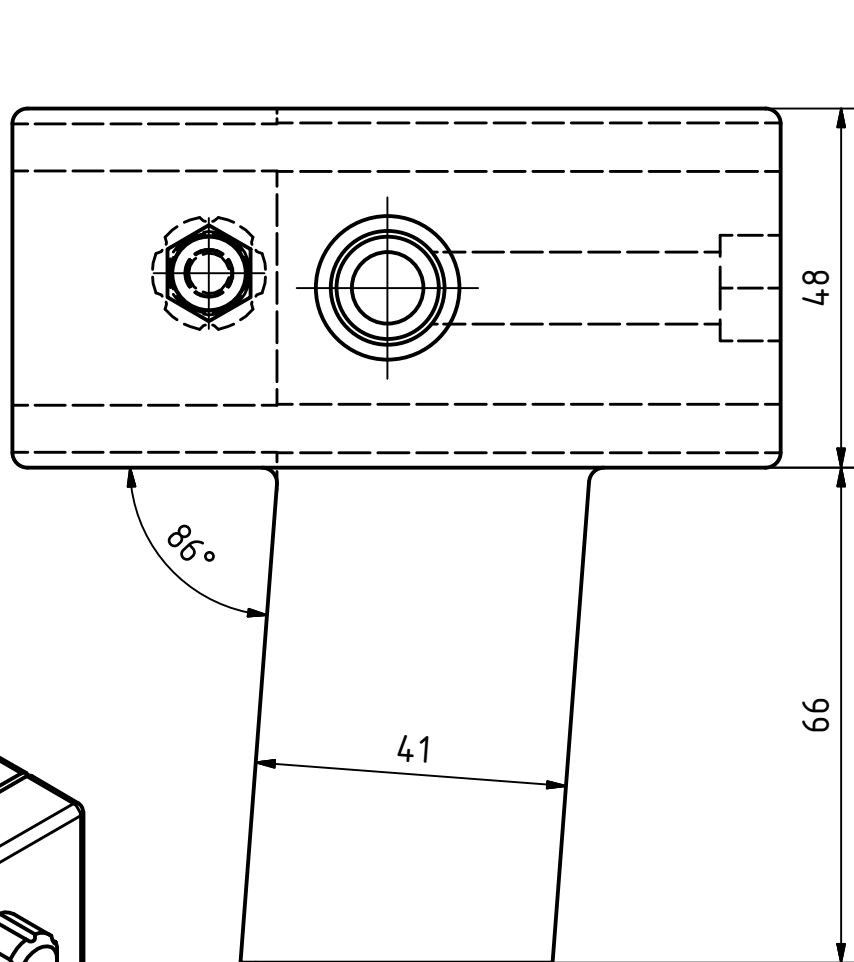
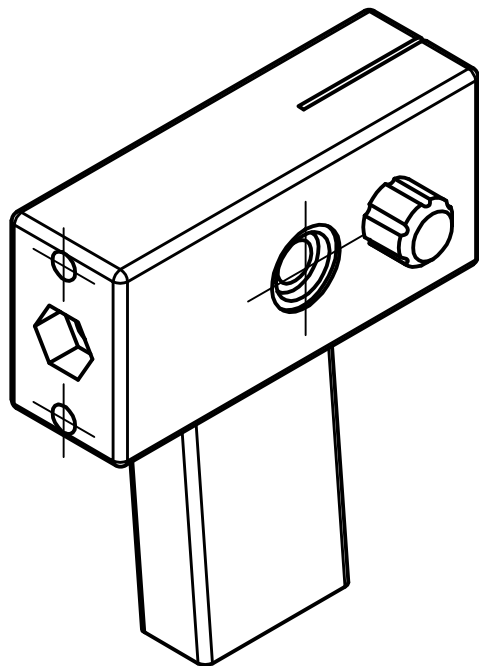

Note: All units in mm.

PROJECT	CREATED BY	APPROVED BY	DATE	VERSION
Welding gun multifuntional & diy	D. MOSQUERA	A. MORILLO	01/08/2021	1.0
PART NAME	FILE NAME			POS
Handle welding	oho_wg_Handle.iam			1.0
PUBLISHED BY	DOC. TYPE	MATERIAL		QUANTITY
 OPEN HARDWARE OBSERVATORY Free Blueprints for Sustainable Development	Assembly			1
	LICENCE	SCALE		SHEET
OHO e.V.	CC-BY-SA 4.0	1:1		5 /22

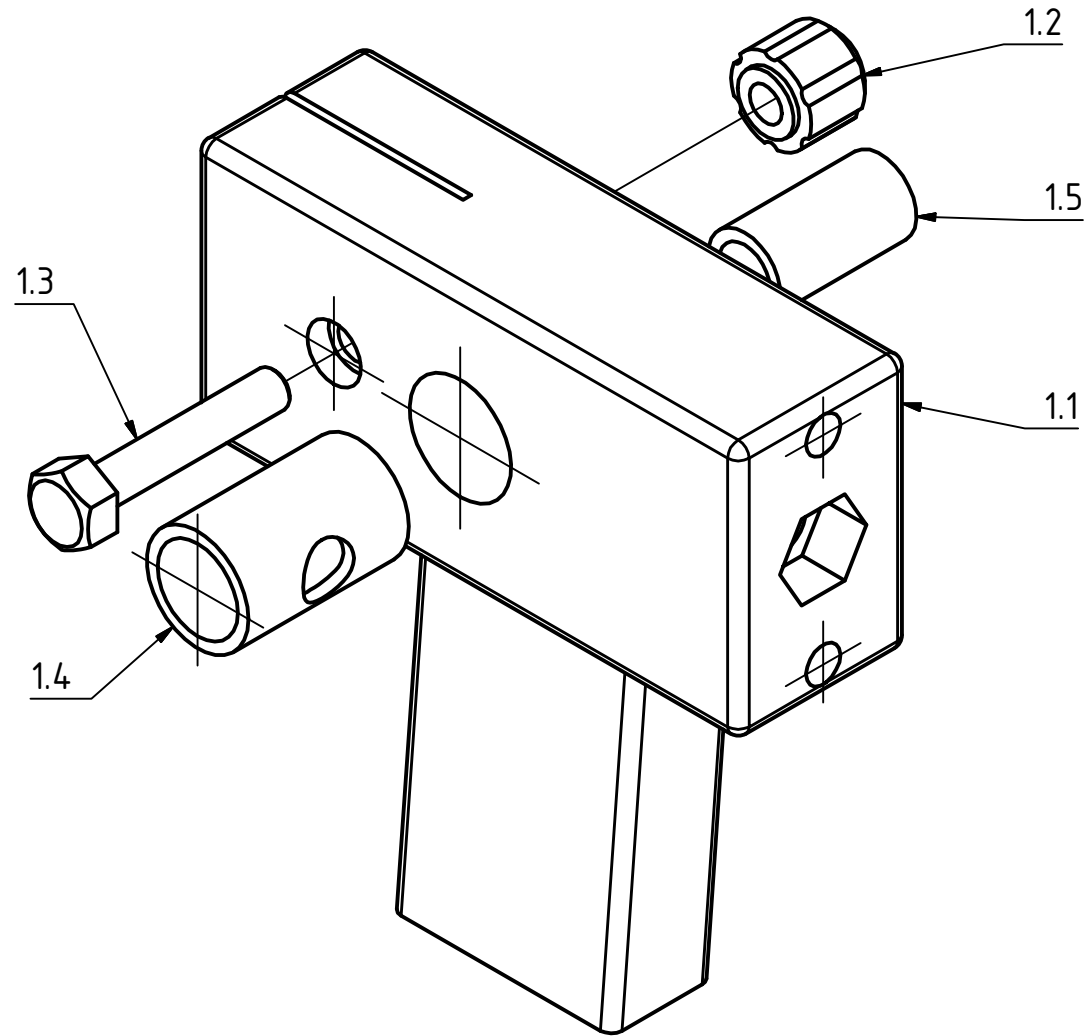

Note: All units in mm.

PROJECT	CREATED BY	APPROVED BY	DATE	VERSION
Welding gun multifuntional & diy	D. MOSQUERA	A. MORILLO	01/08/2021	1.0
PART NAME	FILE NAME			POS
Handle Welding	oho_wg_Handle.ipn			1.0
PUBLISHED BY	DOC. TYPE	MATERIAL		QUANTITY
 OPEN HARDWARE OBSERVATORY Free Blueprints for Sustainable Development OHO e.V.	Assembly			1
	LICENCE	SCALE		SHEET
	CC-BY-SA 4.0	1:1		6 /22

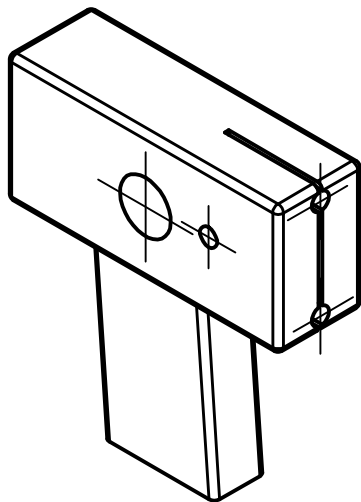
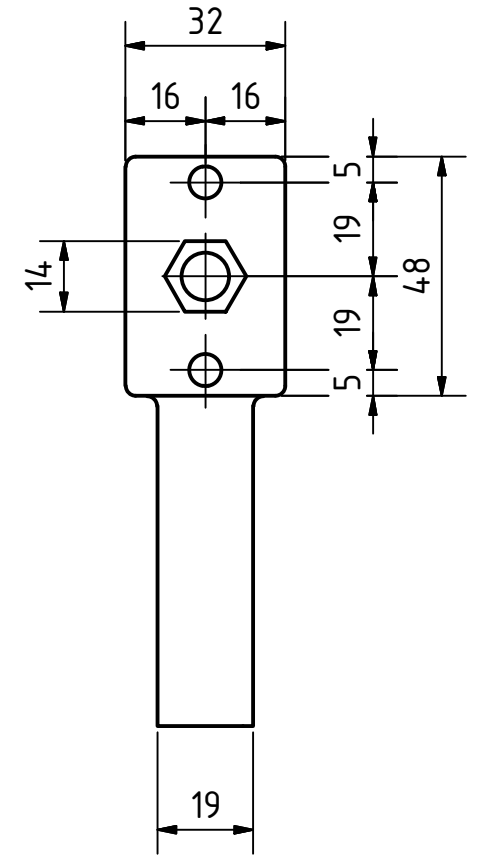
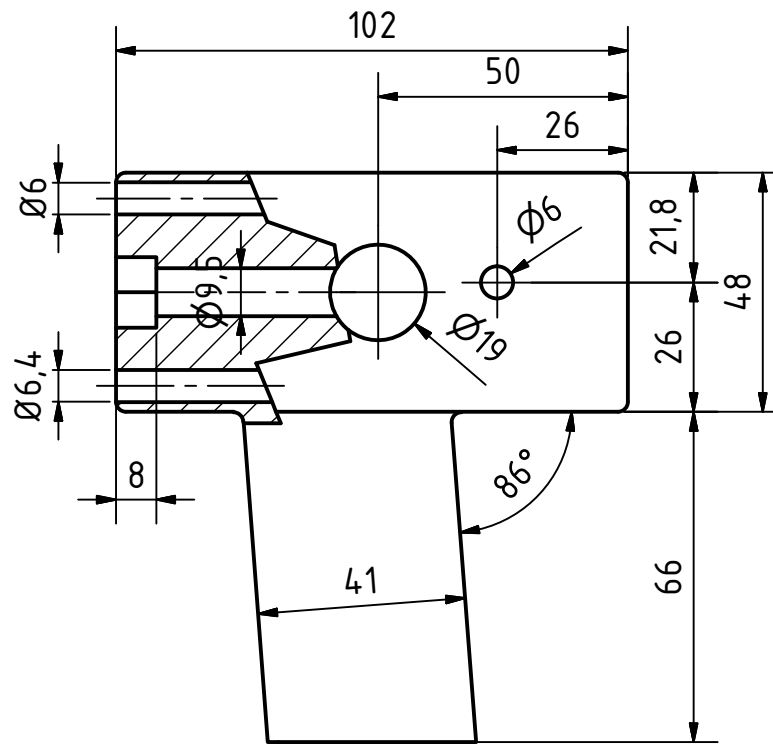
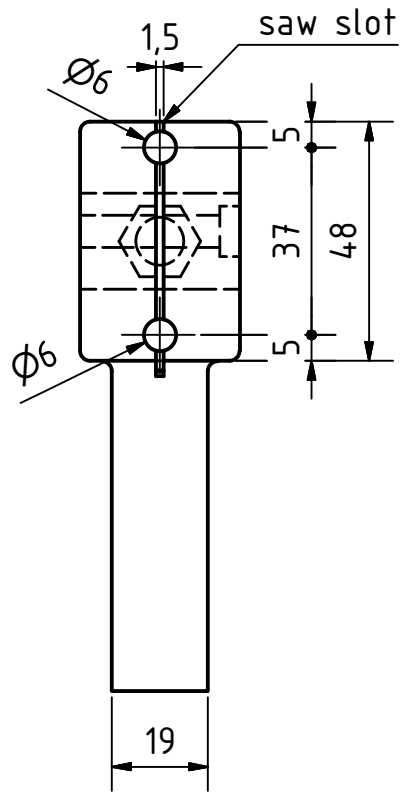

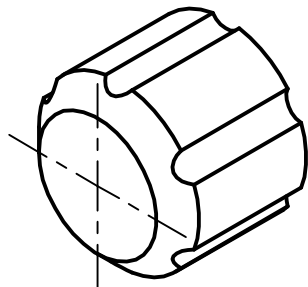
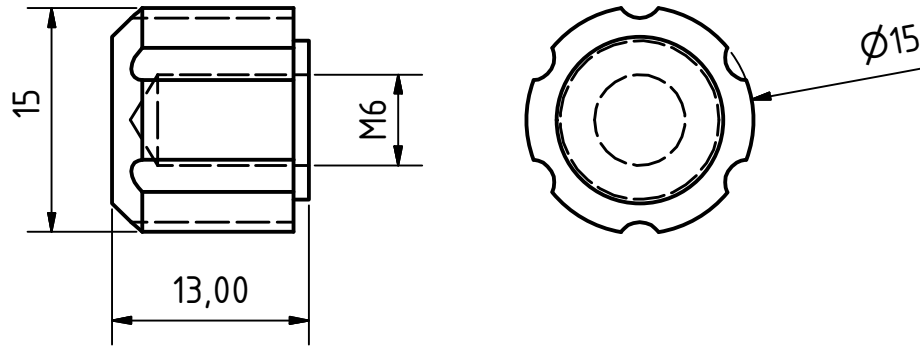

PROJECT	CREATED BY	APPROVED BY	DATE	VERSION
Welding gun multifuntional & diy	D. MOSQUERA	A. MORILLO	01/08/2021	1.0
PART NAME	FILE NAME			POS
Handle	oho_wg_handle.ipt			1.1
PUBLISHED BY	DOC. TYPE	MATERIAL	QUANTITY	
 OPEN HARDWARE OBSERVATORY Free Blueprints for Sustainable Development	Part	Wood	1	
	LICENCE	SCALE	SHEET	
OHO e.V.	CC-BY-SA 4.0	1:1,5	7 /22	



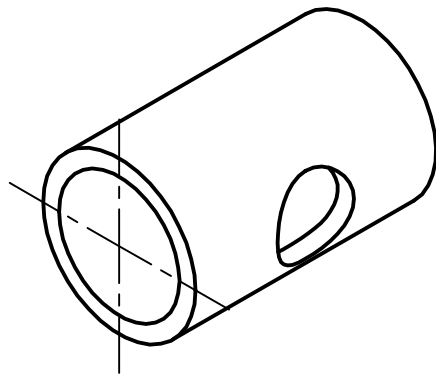
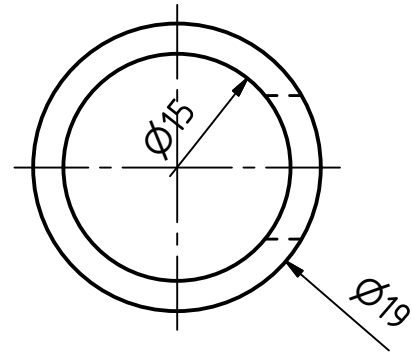
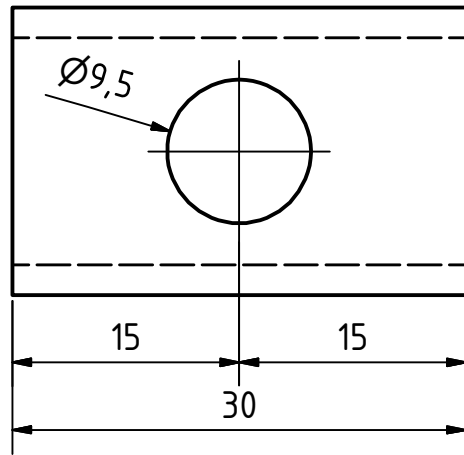

An electronic supply house or radio repair shop can supply a knob of this type

PROJECT	CREATED BY	APPROVED BY	DATE	VERSION
Welding gun multifuntional & diy	D. MOSQUERA	A. MORILLO	01/08/2021	1.0
PART NAME	FILE NAME			POS
Knob	oho_wg_knob.ipt			1.2
PUBLISHED BY	DOC. TYPE	MATERIAL	QUANTITY	
 OPEN HARDWARE OBSERVATORY Free Blueprints for Sustainable Development	Part	Plastic HD	1	
	LICENCE	SCALE	SHEET	
OHO e.V.	CC-BY-SA 4.0	2:1	8 /22	

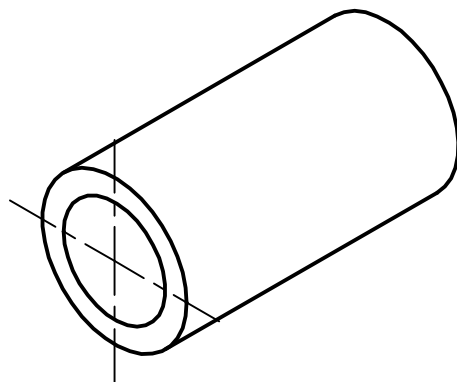
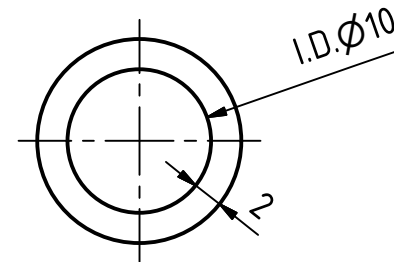
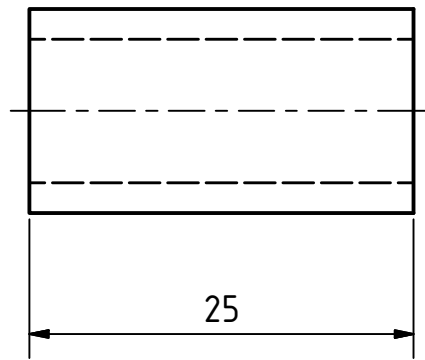

PROJECT	CREATED BY	APPROVED BY	DATE	VERSION
Welding gun multifuntional & diy	D. MOSQUERA	A. MORILLO	01/08/2021	1.0
PART NAME	FILE NAME			POS
Fiber sleeve	oho_wg_fiber-sleeve.ipt			1.4
PUBLISHED BY	DOC. TYPE	MATERIAL	QUANTITY	
 OPEN HARDWARE OBSERVATORY Free Blueprints for Sustainable Development	Part	Fiber or plastic insulation	1	
	LICENCE	SCALE	SHEET	
OHO e.V.	CC-BY-SA 4.0	2:1	9 /22	



PROJECT	CREATED BY	APPROVED BY	DATE	VERSION
Welding gun multifunctional & diy	D. MOSQUERA	A. MORILLO	01/08/2021	1.0
PART NAME	FILE NAME			POS
Copper tube	oho_wg_cooper-tube.ipt			1.5
PUBLISHED BY	DOC. TYPE	MATERIAL	QUANTITY	
 OPEN HARDWARE OBSERVATORY Free Blueprints for Sustainable Development	Part	copper	1	
	LICENCE	SCALE	SHEET	
OHO e.V.	CC-BY-SA 4.0	2:1	10 /22	

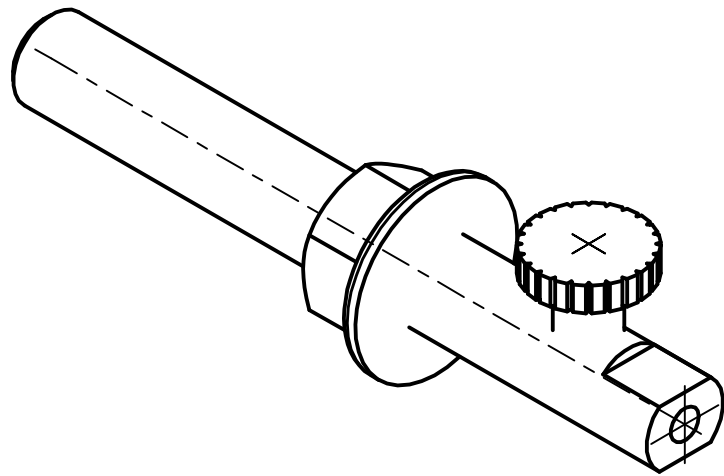
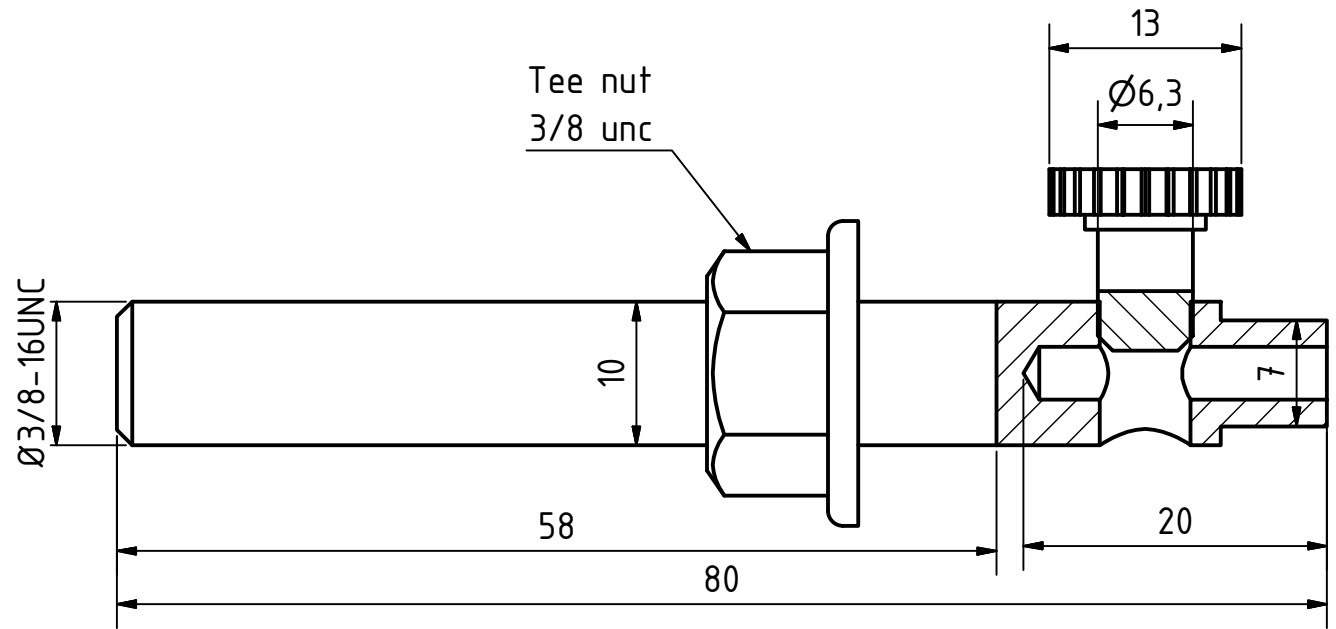
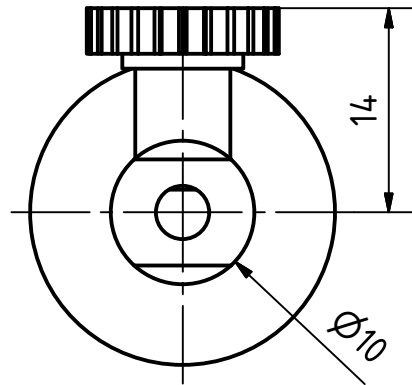

PROJECT	CREATED BY	APPROVED BY	DATE	VERSION
Welding gun multifuntional & diy	D. MOSQUERA	A. MORILLO	01/08/2021	1.0
PART NAME	FILE NAME			POS
Conductor tube	oho_wg_conductor-tube.iam			2.0
PUBLISHED BY	DOC. TYPE	MATERIAL		QUANTITY
 OPEN HARDWARE OBSERVATORY Free Blueprints for Sustainable Development	Assembly			1
	LICENCE	SCALE		SHEET
OHO e.V.	CC-BY-SA 4.0	1:1		11 /22

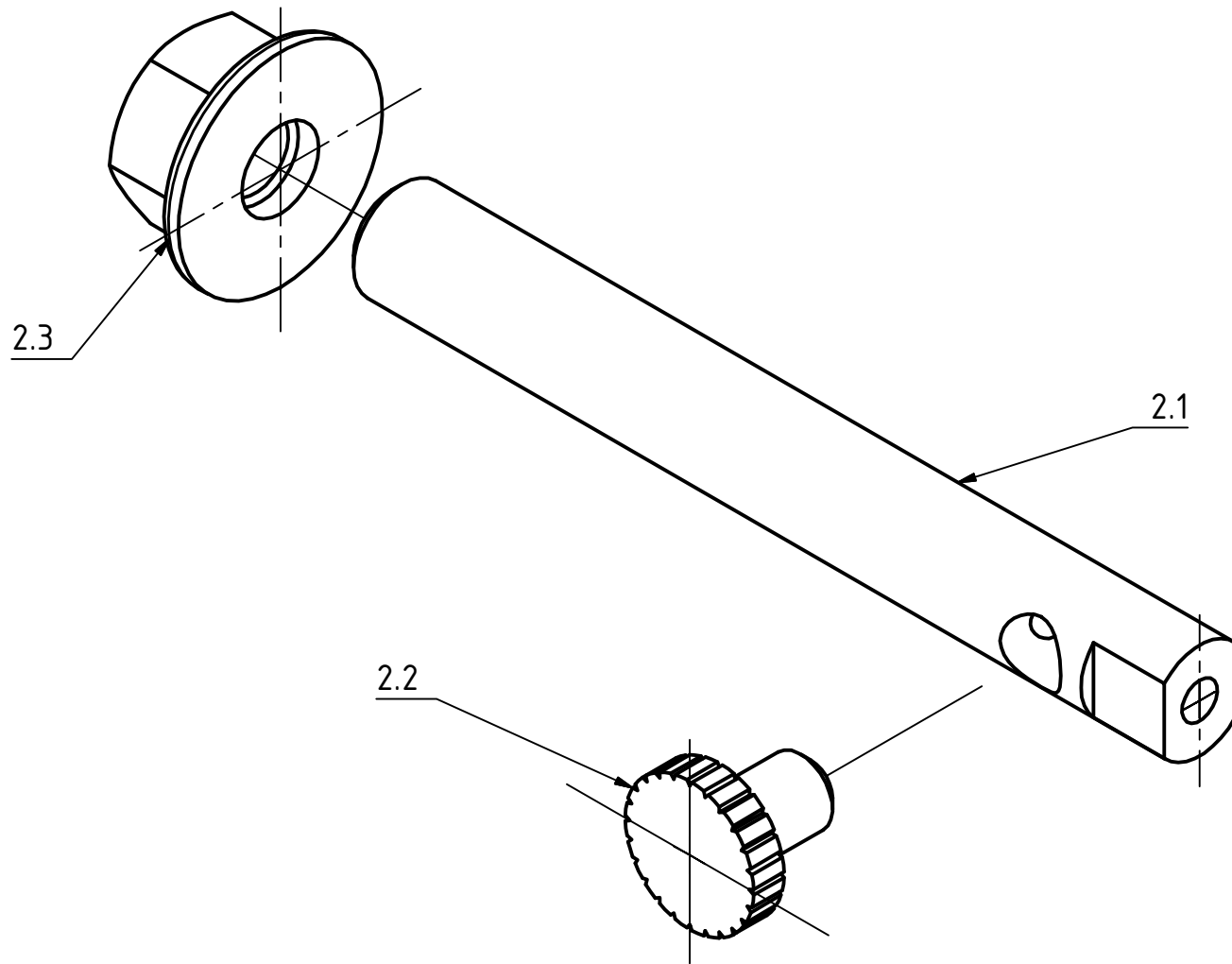

PROJECT	CREATED BY	APPROVED BY	DATE	VERSION
Welding gun multifuntional & diy	D. MOSQUERA	A. MORILLO	01/08/2021	1.0
PART NAME	FILE NAME			POS
Conductor tube	oho_wg_conductor-tube.ipn			2.0
PUBLISHED BY	DOC. TYPE	MATERIAL	QUANTITY	
 OPEN HARDWARE OBSERVATORY Free Blueprints for Sustainable Development OHO e.V.	Assembly		1	
	LICENCE	SCALE	SHEET	
	CC-BY-SA 4.0	2:1	12 /22	

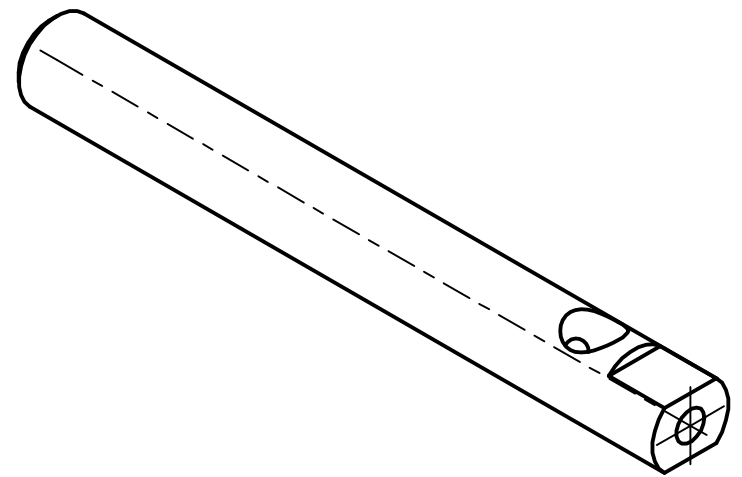
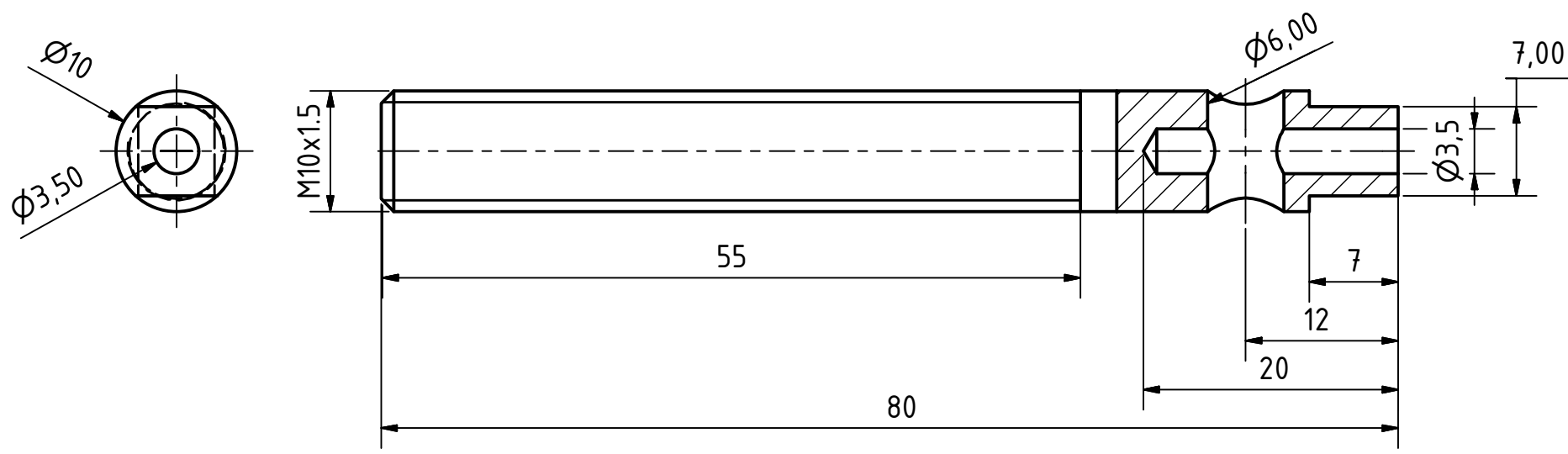

PROJECT	CREATED BY	APPROVED BY	DATE	VERSION
Welding gun multifuntional & diy	D. MOSQUERA	A. MORILLO	01/08/2021	1.0
PART NAME	FILE NAME			POS
Tube	oho_wg_conductor-tube.ipt			2.1
PUBLISHED BY	DOC. TYPE	MATERIAL	QUANTITY	
 OPEN HARDWARE OBSERVATORY Free Blueprints for Sustainable Development	Part	copper	1	
	LICENCE	SCALE	SHEET	
OHO e.V.	CC-BY-SA 4.0	2:1	13 /22	

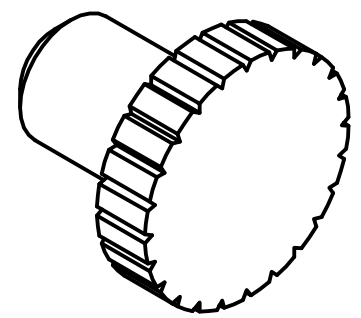
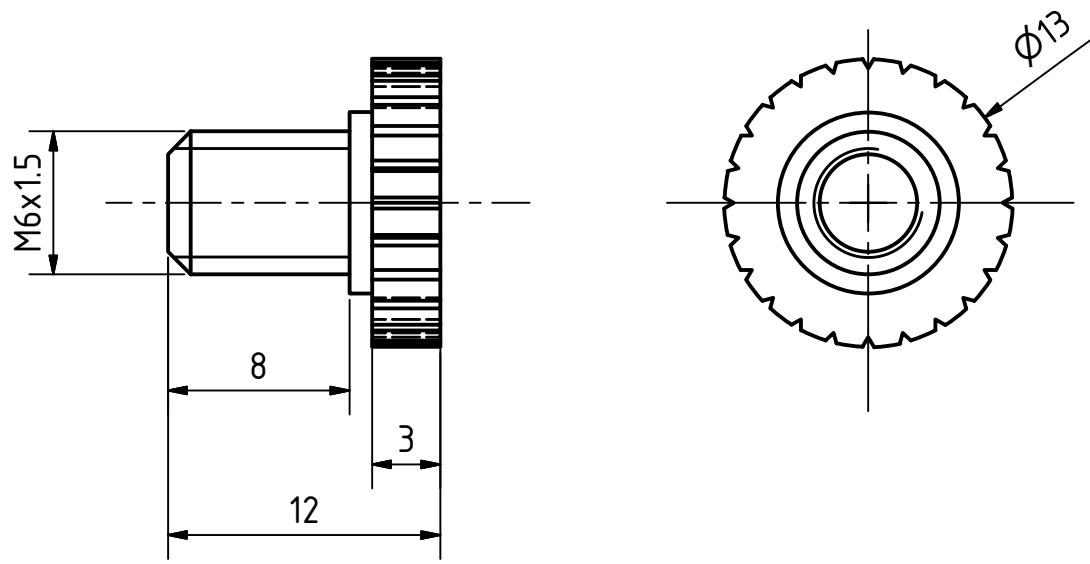

PROJECT	CREATED BY	APPROVED BY	DATE	VERSION
Welding gun multifuntional & diy	D. MOSQUERA	A. MORILLO	01/08/2021	1.0
PART NAME	FILE NAME			POS
Bolt M6	oho_wg_bolt-1-4x19.ipt			2.2
PUBLISHED BY	DOC. TYPE	MATERIAL		QUANTITY
 OPEN HARDWARE OBSERVATORY Free Blueprints for Sustainable Development	Part	Steel C45		1
	LICENCE	SCALE		SHEET
OHO e.V.	CC-BY-SA 4.0	3:1		14 /22

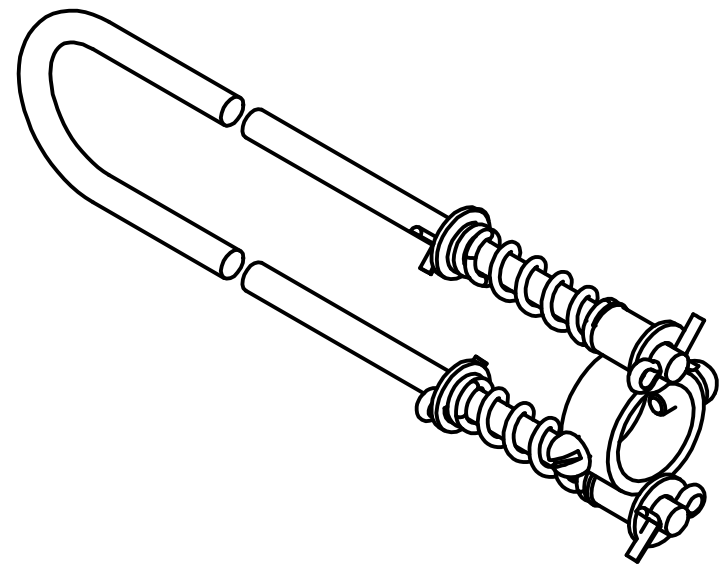
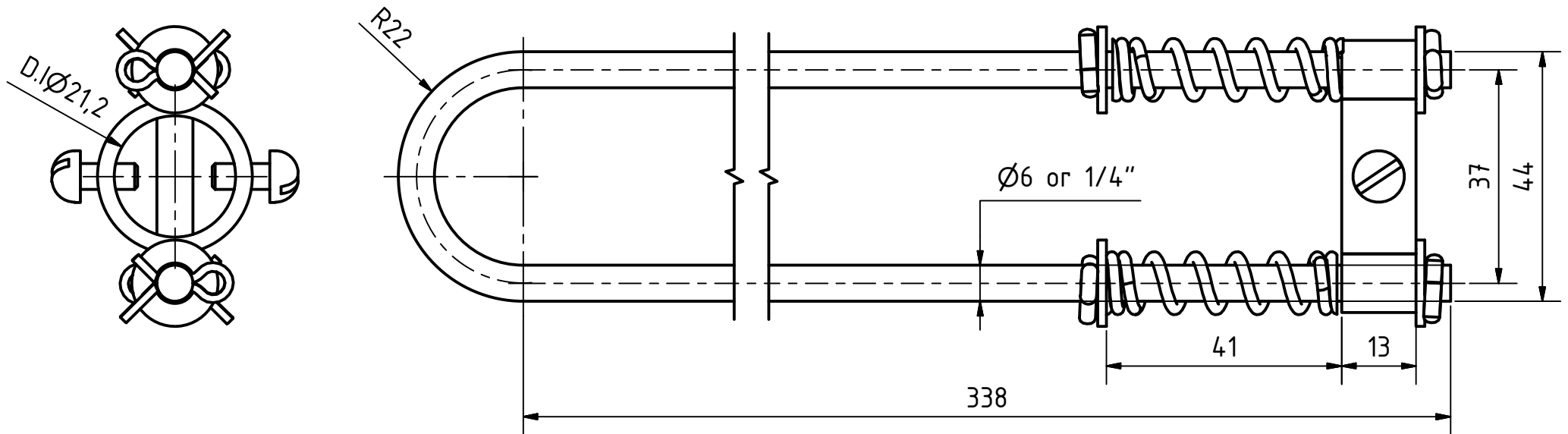

PROJECT	CREATED BY	APPROVED BY	DATE	VERSION
Welding gun multifuntional & diy	D. MOSQUERA	A. MORILLO	01/08/2021	1.0
PART NAME	FILE NAME			POS
Brass rod	oho_wg_Brass rod.iam			3.0
PUBLISHED BY	DOC. TYPE	MATERIAL	QUANTITY	
 OPEN HARDWARE OBSERVATORY Free Blueprints for Sustainable Development	Assembly		1	
	LICENCE	SCALE	SHEET	
OHO e.V.	CC-BY-SA 4.0	1:2	15 /22	

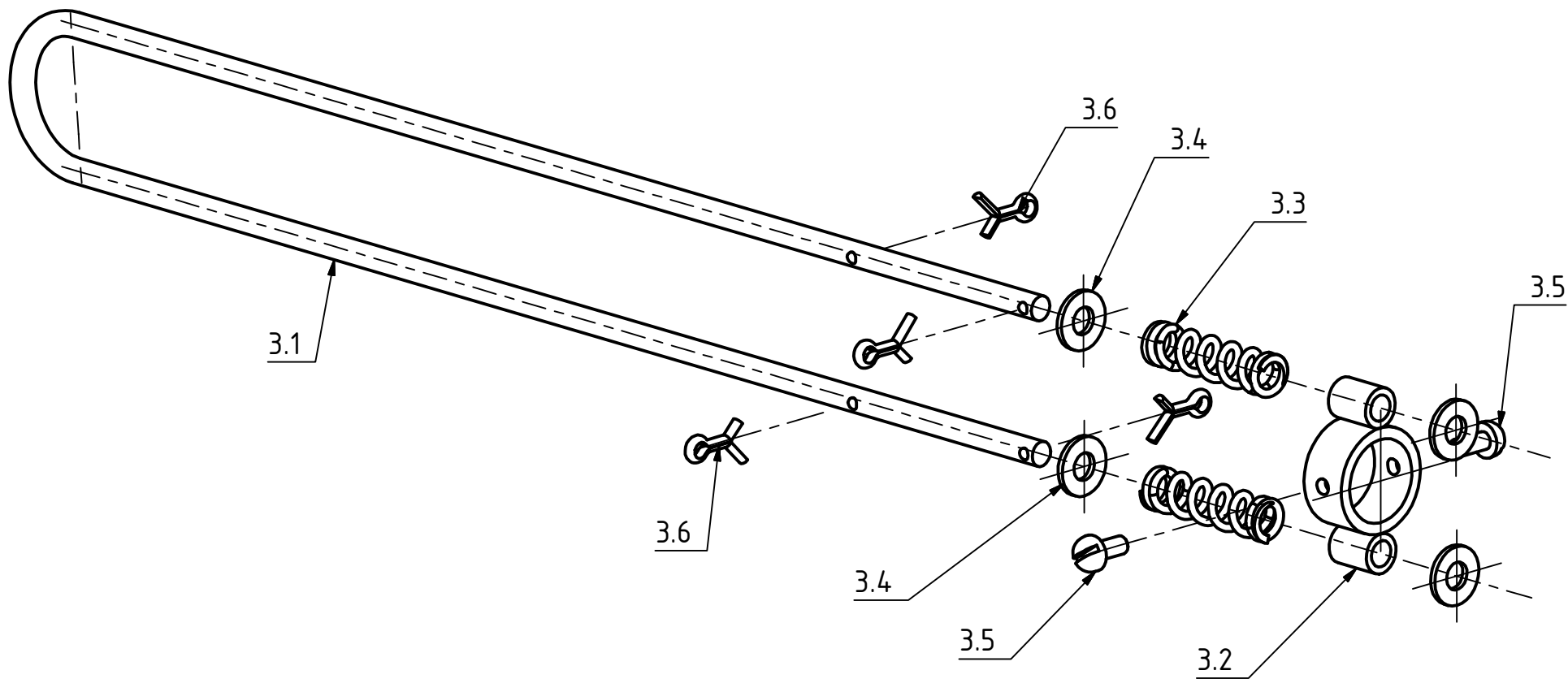

PROJECT	CREATED BY	APPROVED BY	DATE	VERSION
Welding gun multifuntional & diy	D. MOSQUERA	A. MORILLO	01/08/2021	1.0
PART NAME	FILE NAME			POS
Brass rod	oho_wg_Brass rod.ipn			3.0
PUBLISHED BY	DOC. TYPE	MATERIAL		QUANTITY
 OPEN HARDWARE OBSERVATORY Free Blueprints for Sustainable Development	Assembly			1
	LICENCE	SCALE		SHEET
OHO e.V.	CC-BY-SA 4.0	1,5:1		16 /22

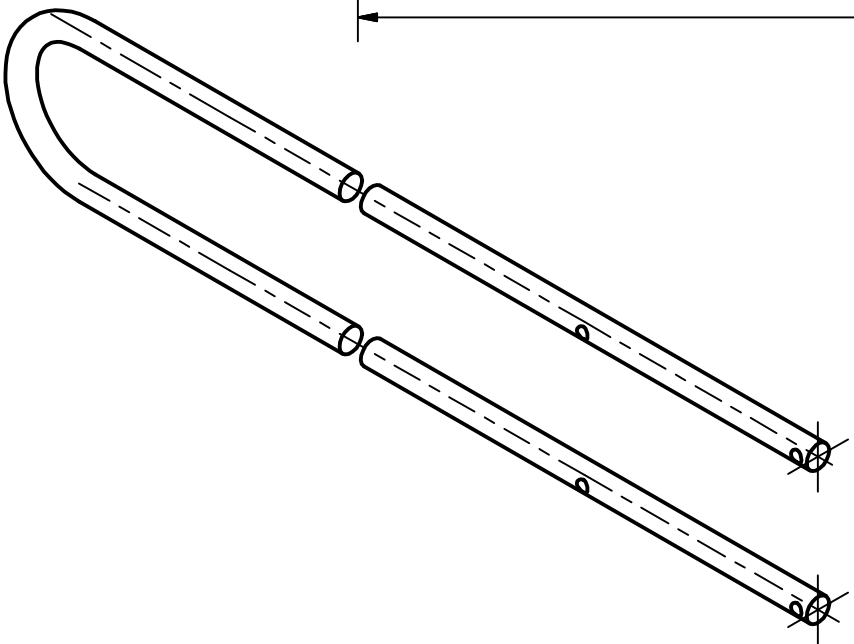
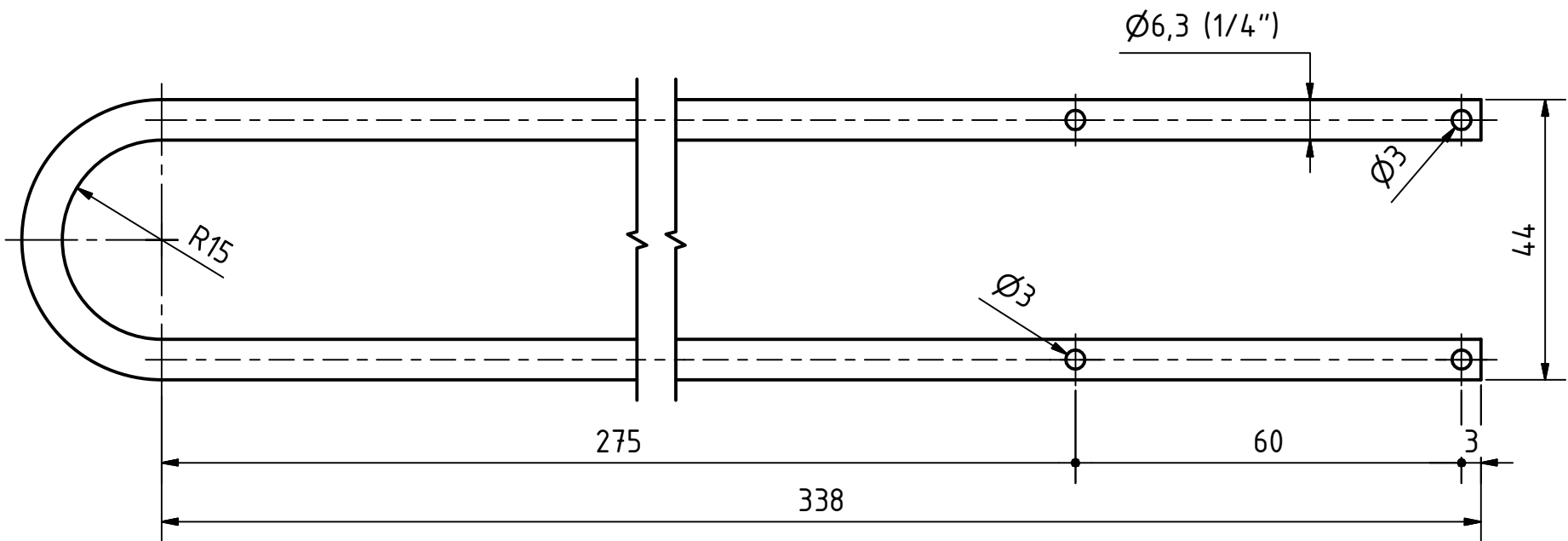

PROJECT	CREATED BY	APPROVED BY	DATE	VERSION
Welding gun multifuntional & diy	D. MOSQUERA	A. MORILLO	01/08/2021	1.0
PART NAME	FILE NAME			POS
Slide rod	oho_wg_slide-rod.ipt			3.1
PUBLISHED BY	DOC. TYPE	MATERIAL	QUANTITY	
 OPEN HARDWARE OBSERVATORY Free Blueprints for Sustainable Development	Part	brass, bronze	1	
	LICENCE	SCALE	SHEET	
OHO e.V.	CC-BY-SA 4.0	1:1	17 /22	

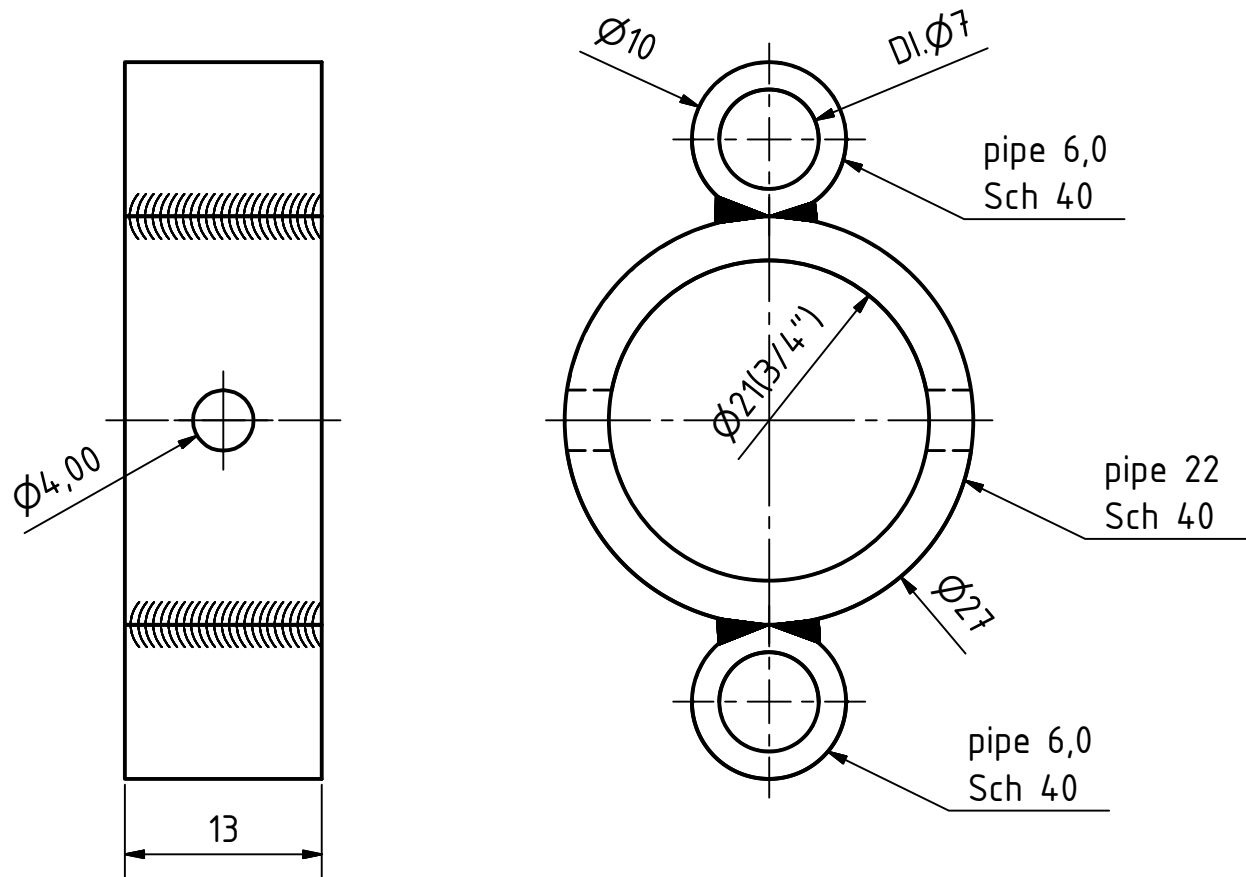
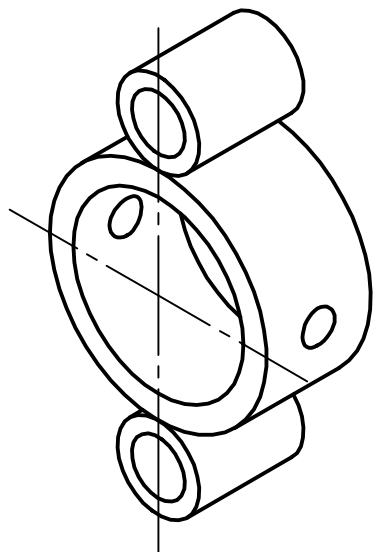

PROJECT	CREATED BY	APPROVED BY	DATE	VERSION
Welding gun multifuntional & diy	D. MOSQUERA	A. MORILLO	01/08/2021	1.0
PART NAME	FILE NAME			POS
suport	oho_wg_suport.iam			3.2
PUBLISHED BY	DOC. TYPE	MATERIAL		QUANTITY
 OPEN HARDWARE OBSERVATORY Free Blueprints for Sustainable Development	Part	Steel C45		1
	LICENCE	SCALE		SHEET
OHO e.V.	CC-BY-SA 4.0	2:1		18 /22

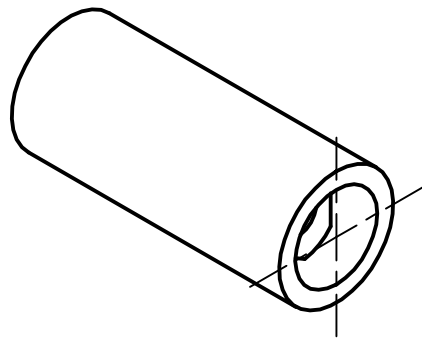
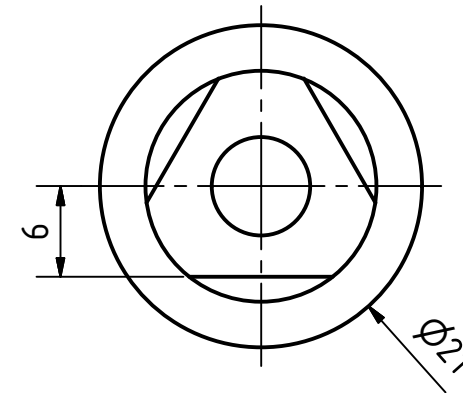
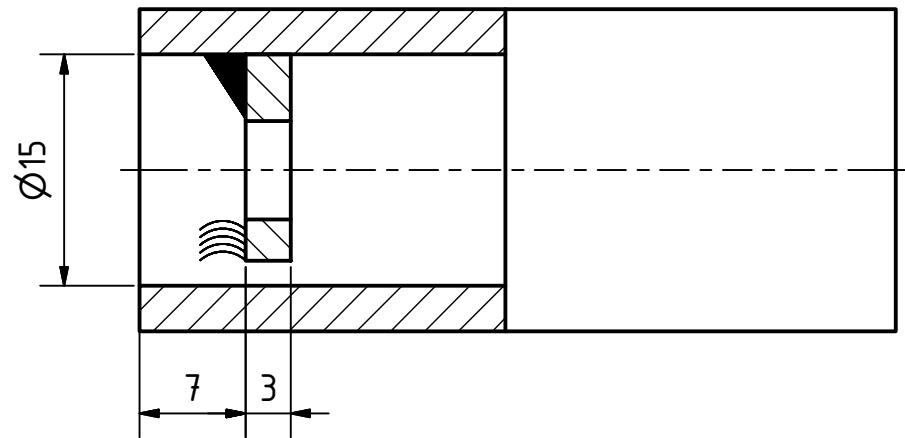

PROJECT	CREATED BY	APPROVED BY	DATE	VERSION
Welding gun multifuntional & diy	D. MOSQUERA	A. MORILLO	01/08/2021	1.0
PART NAME	FILE NAME			POS
Nozzle holder	oho_wg_nozzle-holder.iam			4.0
PUBLISHED BY	DOC. TYPE	MATERIAL	QUANTITY	
 OPEN HARDWARE OBSERVATORY Free Blueprints for Sustainable Development OHO e.V.	Assembly		1	
	LICENCE	SCALE	SHEET	
	CC-BY-SA 4.0	2:1	19 /22	

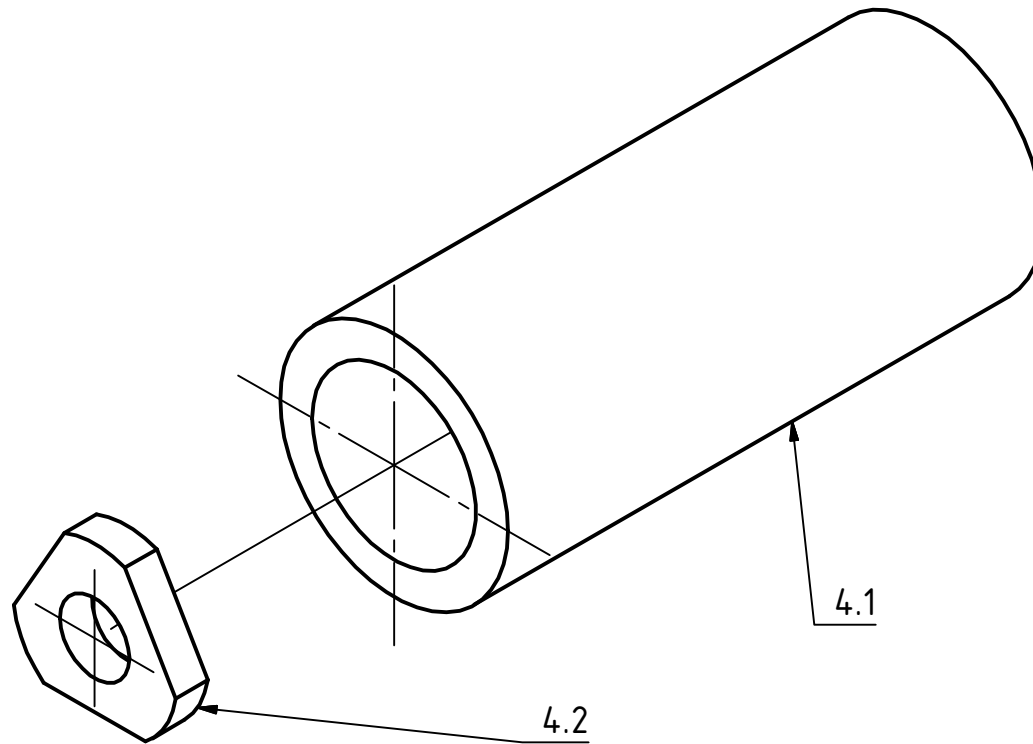

PROJECT	CREATED BY	APPROVED BY	DATE	VERSION
Welding gun multifunctional & diy	D. MOSQUERA	A. MORILLO	01/08/2021	1.0
PART NAME	FILE NAME			POS
Nozzle holder	oho_wg_nozzle-holder.ipn			4.0
PUBLISHED BY	DOC. TYPE	MATERIAL	QUANTITY	
 OPEN HARDWARE OBSERVATORY Free Blueprints for Sustainable Development OHO e.V.	Assembly		1	
	LICENCE	SCALE	SHEET	
	CC-BY-SA 4.0	2:1	20 /22	

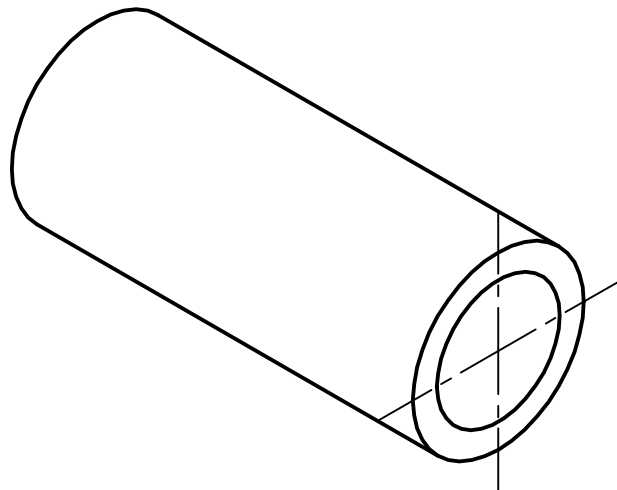
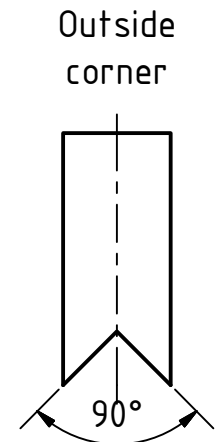
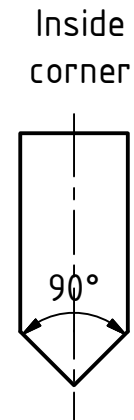
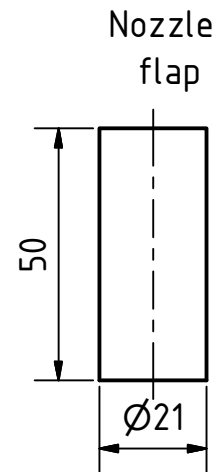
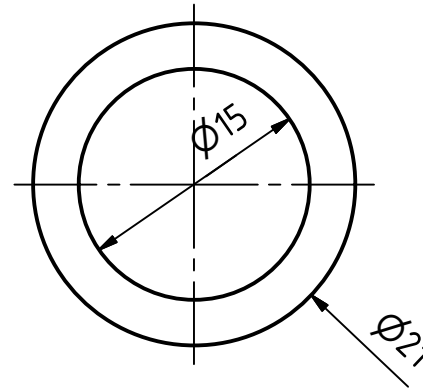
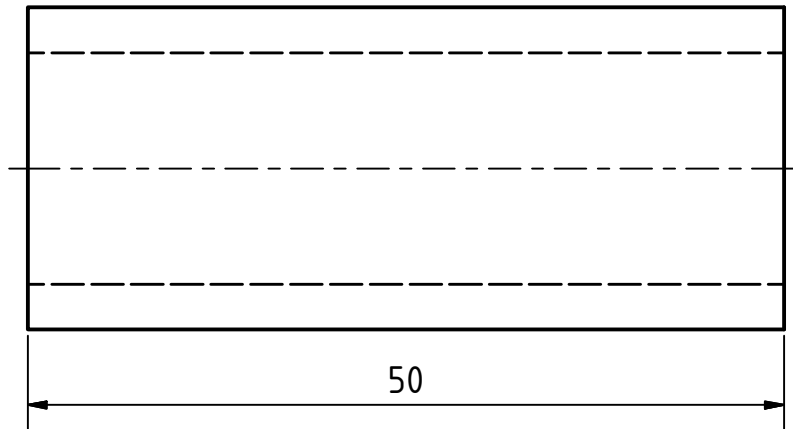

PROJECT	CREATED BY	APPROVED BY	DATE	VERSION
Welding gun multifuntional & diy	D. MOSQUERA	A. MORILLO	01/08/2021	1.0
PART NAME	FILE NAME			POS
Nozzle	oho_wg_nozzle-holder.ipt			4.1
PUBLISHED BY	DOC. TYPE	MATERIAL	QUANTITY	
 OPEN HARDWARE OBSERVATORY Free Blueprints for Sustainable Development	Part	copper	1	
	LICENCE	SCALE	SHEET	
OHO e.V.	CC-BY-SA 4.0	2:1	21 /22	

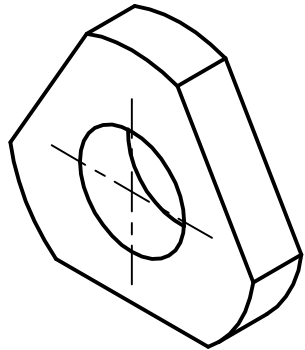
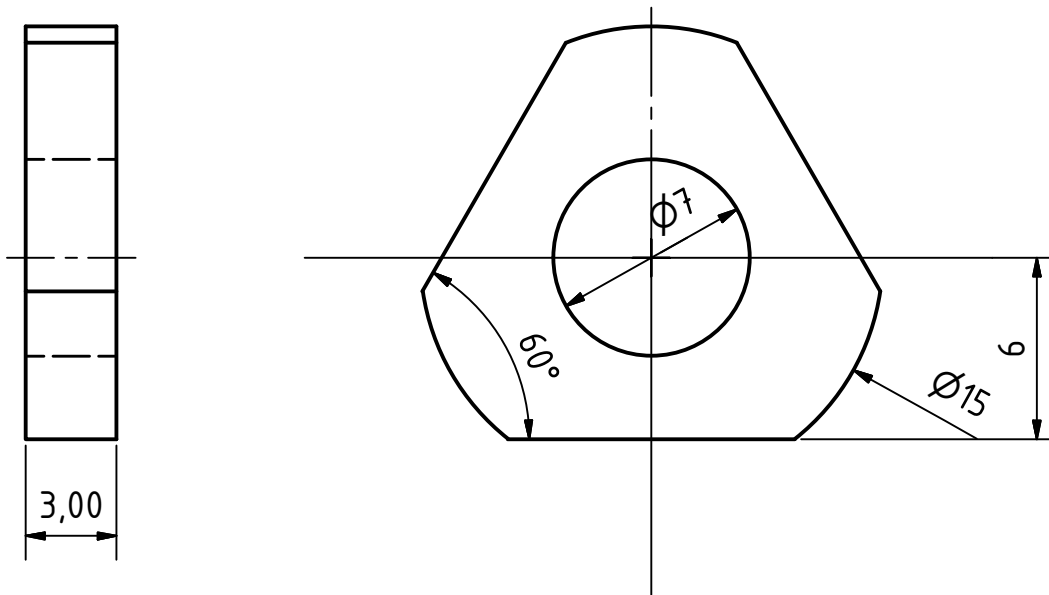

PROJECT	CREATED BY	APPROVED BY	DATE	VERSION
Welding gun multifuntional & diy	D. MOSQUERA	A. MORILLO	01/08/2021	1.0
PART NAME	FILE NAME			POS
Sheet hole	oho_wg_sheet-hole.ipt			4.2
PUBLISHED BY	DOC. TYPE	MATERIAL	QUANTITY	
 OPEN HARDWARE OBSERVATORY Free Blueprints for Sustainable Development	Part	Steel C45	1	
	LICENCE	SCALE	SHEET	
OHO e.V.	CC-BY-SA 4.0	4:1	22 /22	