

# Flamingo rope pump

## PTP2011

### Construction manual

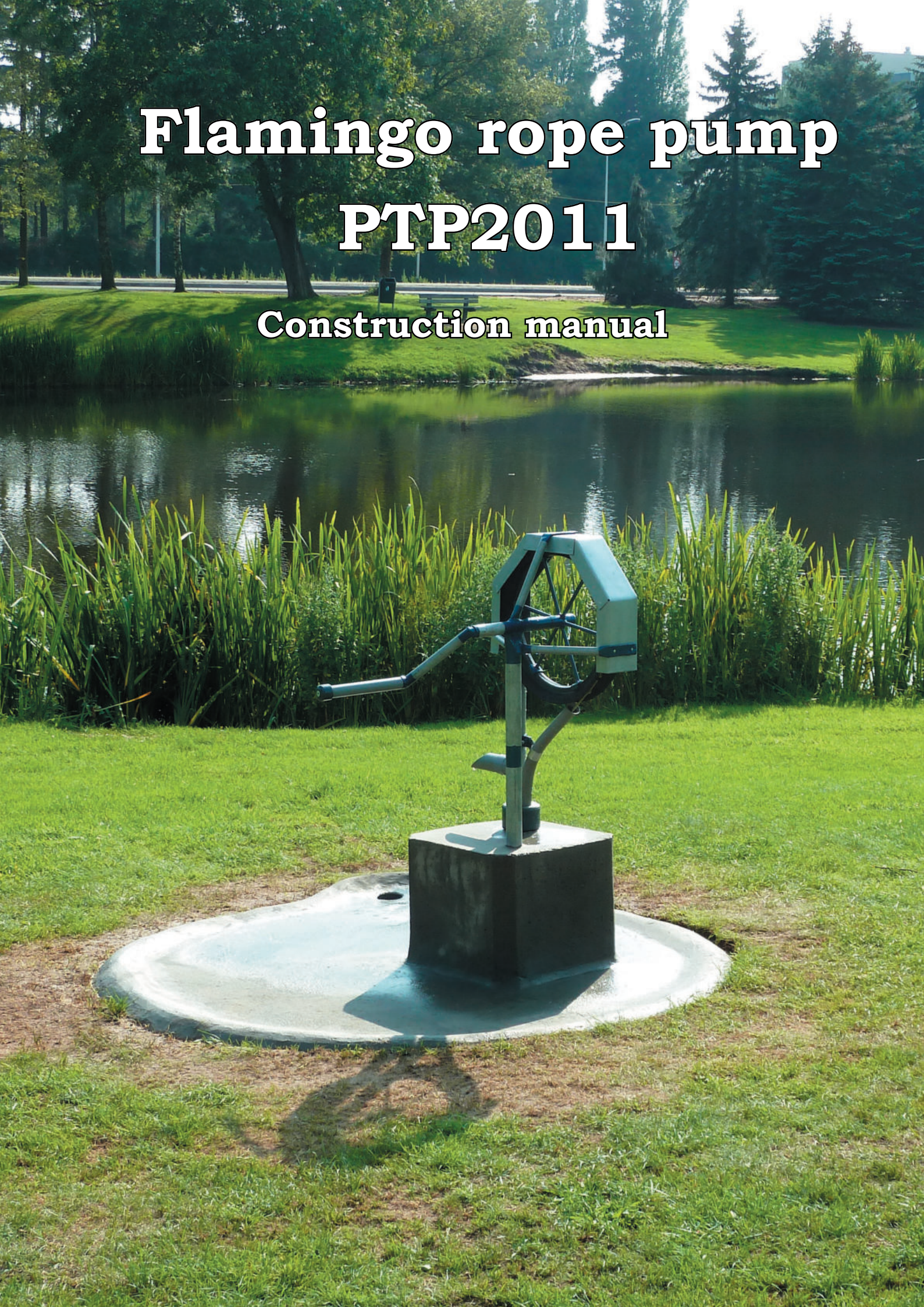

This construction manual is a publication of:

Werkgroep OntwikkelingsTechnieken (WOT)  
University of Twente  
P.O. box 217  
7500 AE Enschede  
wot@utwente.nl  
www.wot.utwente.nl

Autor: Freddy Alferink

Text editing:

Illustrations: Freddy Alferink

Design of the PTP2011 Flamingo Rope Pump: Ton Pütt and Freddy Alferink

Special thanks to:

Henk Holtslag for his review and comments on the design. Members of the WOT who helped installing the prototype.

WOT, november 2012.

# Contents

<b>Principle of working</b>	<b>4</b>	Pump clamp	20
Key features	4	Return tube clamp	20
<b>Pump capacity</b>	<b>4</b>	<b>Frame installation</b>	<b>21</b>
<b>General techniques</b>	<b>5</b>	<b>The pump</b>	<b>23</b>
Sawing	5	<b>Rising main</b>	<b>23</b>
Squeezing pipe ends	5	Making a flare	23
Welding	5	<b>The inlet guide</b>	<b>24</b>
Painting	5	The inlet bracket	24
Concrete	5	Inlet guide assembly	24
<b>Bulding the frame</b>	<b>5</b>	Rope guide	24
<b>The Wheel</b>	<b>6</b>	Top and outlet pipes	25
Preparing the tire	6	Reduction	25
The hub	6	Coupling pipe	25
Spokes and tire clamps	7	Return tube	26
Welding the wheel	7	<b>Pump installation</b>	<b>27</b>
Adjusting the wheel	8	Pistons	27
Painting	8	Rope	27
<b>The handle</b>	<b>9</b>	The rising main	28
Sawing the tubes	9	Rope installation	29
Welding the tubes	9	Rope coupling	30
Rings	10	<b>Maintenance</b>	<b>30</b>
Locking lugs	10	<b>Jigs</b>	<b>31</b>
The grip	10	Cover bracket bend jig	31
Locking the grip	10	Pump support bend jig	31
<b>The frame</b>	<b>11</b>	Handle jig	31
Bearing bush	11	Frame angle jig	32
Post	11	Cover bracket jig	32
Welding the bushing to the frame	12	Wheel welding jig	33
Vertical cover bracket	13	Return tube jig	33
Horizontal cover bracket	13	<b>Errata</b>	<b>34</b>
Welding the cover brackets	14	Orientation pump	34
Anchor bracket	15	Concrete block	34
Pump support arm	16	Pump clamp	34
Mounting the pump support arm	16		
Painting the frame	16		
The wheel cover	17		
<b>Frame assembly</b>	<b>18</b>		
Mounting the cover	18		
Mounting the handle	18		
Wheel assembly	19		
Bore hole cover	19		

## Principle of working

The basic parts of a rope pump are the rising main and the rope with the pistons. The rising main is a pipe, usually made of PVC, that hangs with one end in the ground water and the other end above the ground. By moving the rope, and therefore the pistons upward, water will be lifted.

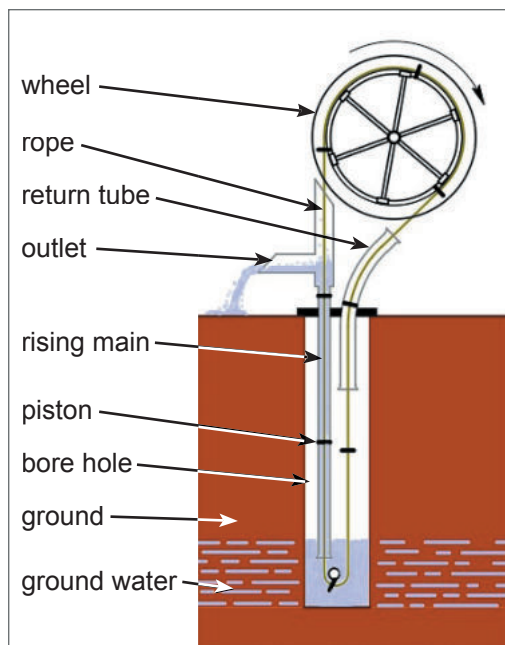

To ease the driving of the rope through the pipe a wheel is used and the rope is made endless by knotting both rope ends together.

### Key features

The wheel is made of the side walls from a car tire. By putting the two walls together a sharp V-shape is created. This V-shape ensures that the wheel has a good grip on the rope so it won't slip and thereby prevents excessive tear and wear.

The pump and inlet guide are made completely from PVC. No iron parts are present in the

water of the well who otherwise corrode easily.

The frame is based on a simple one pole structure that reduces costs and simplifies the manufacturing. The bearing for the wheel axle is made out of one piece of pipe. This avoids aligning problems. The bearing has an integrated automatic one directional brake. This will prevent that the wheel and handle turn in the opposite direction by the pulling action from the water in the raising main when stopped with pumping.

## Pump capacity

How much water a hand pump can deliver is determined by the strength of the user. The general assumed input power is approximately 80 Watt. The rope pump will be operated at an average revolving speed of one turn every second. With the use of a wheel made out of the prescribed 14" tire, the lifted water mass is limited to 7 kg. When simple rubber discs are used for the pistons, the hydraulic efficiency will be approximately 80 % which reduces the amount of water that is pumped. This all together results in the table below:

**Table 1: lifting height, pipe diameter and pump capacity**

Lifting height [m]	0...6	6...11	11...17	17...35
Tube outer diameter [mm]	Ø40	Ø32	Ø25	Ø19
Tube inner diameter [mm]	Ø37,4	Ø28,4	Ø23,0	Ø16,2
Pump capacity [liter/minute]	80	45	30	15

Use this prescribed pipe diameter for the given lifting height! When using a larger pipe diameter the pump will work too heavy to use.



Wheel side view with sharp V-shape



## **General techniques**

### **Sawing**

Use a sharp iron saw for sawing the galvanised steel pipe and PVC-pipe. Deburr the edges with a file.

### **Squeezing pipe ends**

Some pipe ends must be squeezed to make welding easier. Pay attention to the final thickness mentioned in the drawings.

### **Welding**

All weldings are done with 3.25 mm rutile electrodes at 120 ampere. Use a welding mask with a shade 10 to protect your eyes. Before welding remove all the sink plating and loose rust at the places where the parts are welded together.

### **Painting**

The bare metals and the places where the parts are welded together have to be painted to protect it against rust. The galvanised pipe is protected against rust by itself. Before painting undo the parts thoroughly from grease and dust.

### **Concrete**

Don't expose fresh poured concrete to the full sun. Cover the concrete with plastic foil and keep it continuously wet for at least 4 days after pouring. After pouring concrete compact the mass by jab it with a stick.

## **Bulding the frame**

The following pages describe how to build the wheel, handle and the frame.

## The Wheel



### Preparing the tire

The two rubber parts that make the V-shaped wheel are made from a 14" car tire. The inner parts has to cut out. To guarantee the right dimensions, the tire has to be marked out first with the marking tool below.

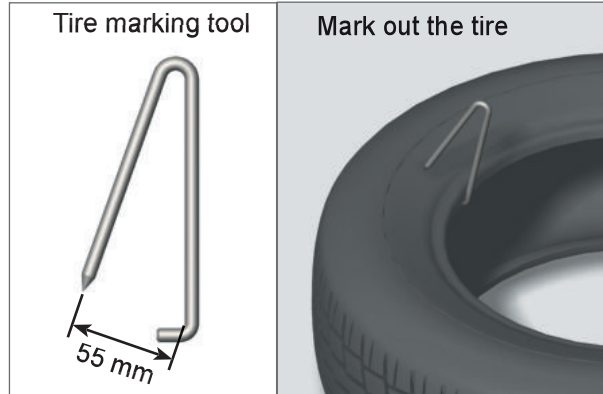

Cut the tire as shown in the picture below. Do this on both sides. The cutting is easiest done by using a serrated knife and by lubricating the rubber with water.

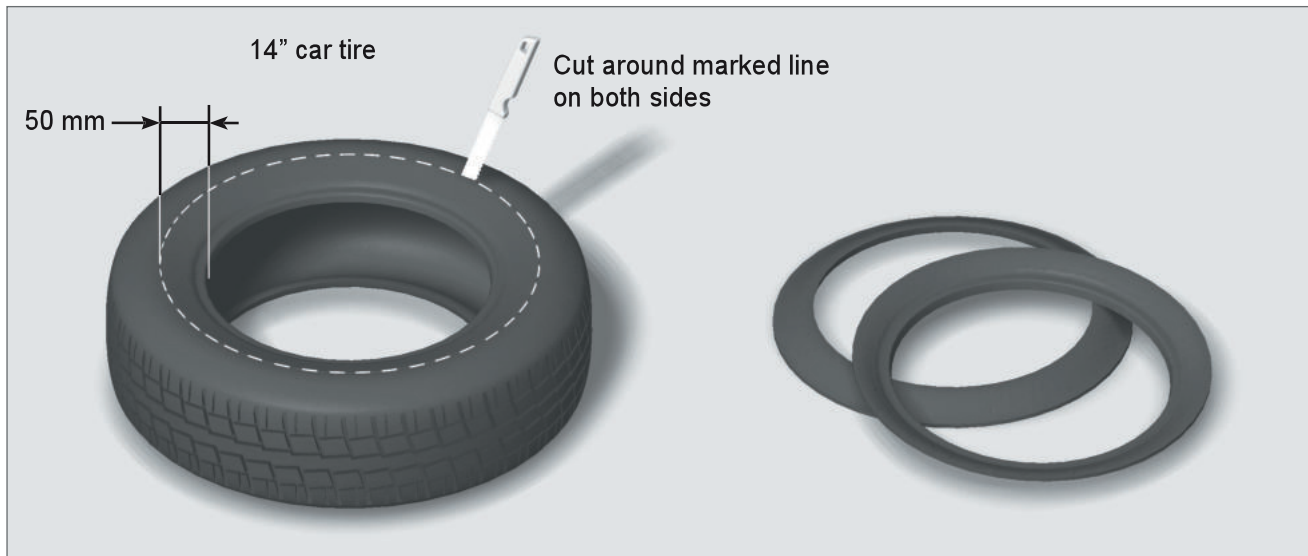

### The hub

The hub is made of an 80 mm long, 1" galvanized steel pipe. Drill two 11 mm holes in the side wall.

M10 nuts must be welded above the two holes. Fixate the nuts to easy the welding.

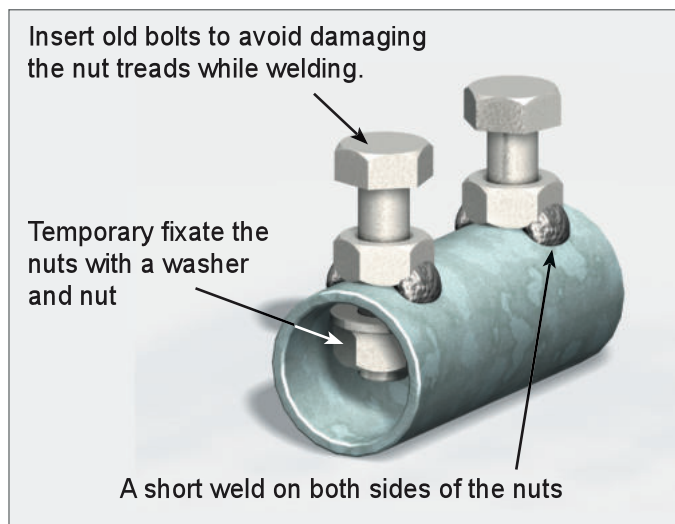
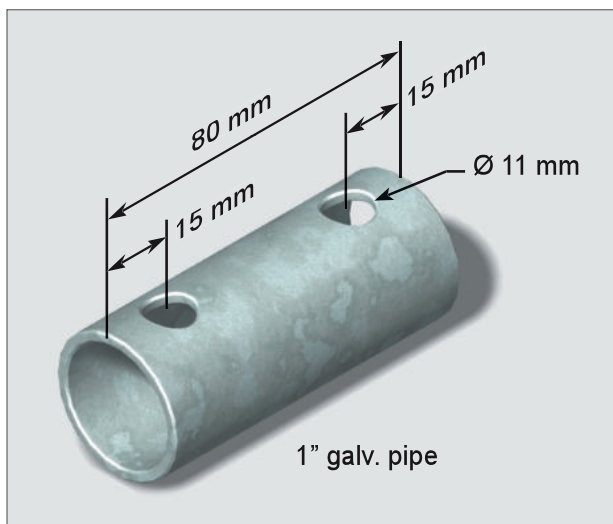

## Spokes and tire clamps

Each wheel requires six spokes and tire clamps.

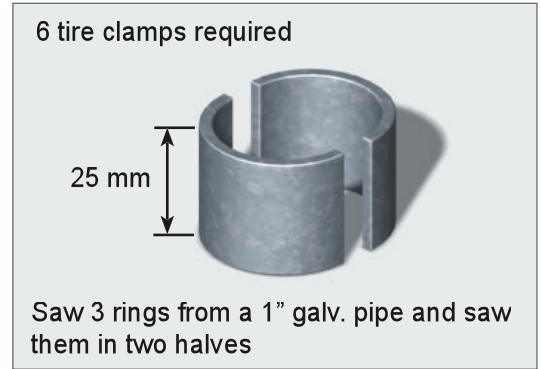
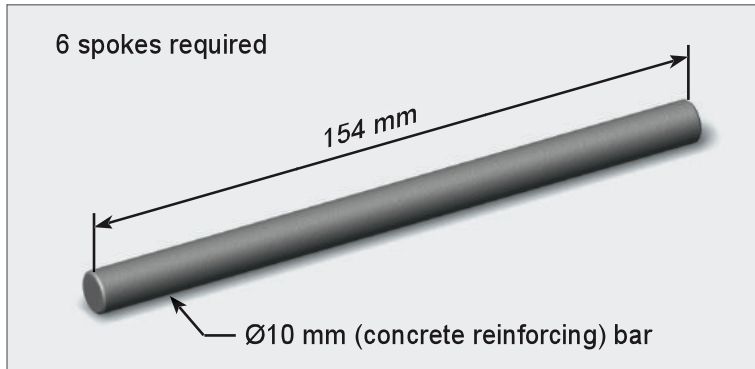

## Welding the wheel

A welding jig will ease the alignment and welding of the wheel parts. The wheel jig is described on page 33.

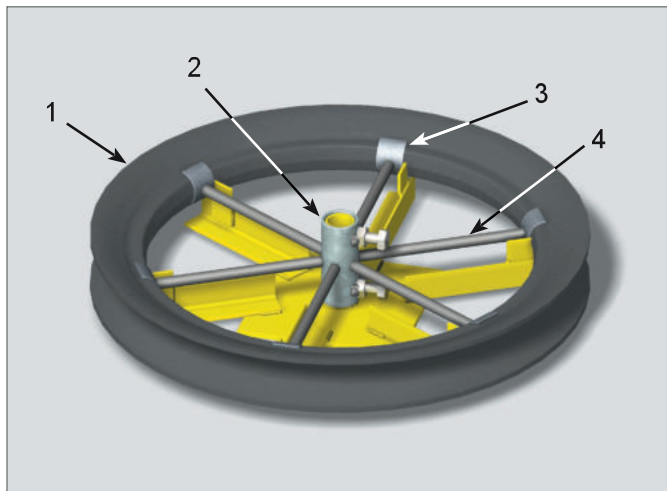
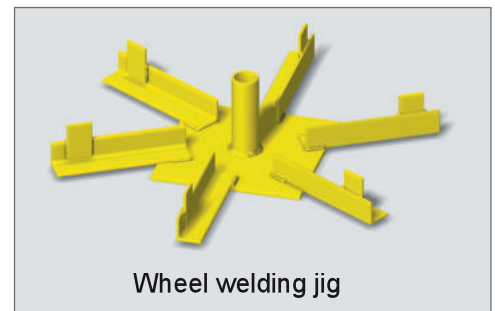

- 1) Place the tire parts on the jig.
- 2) Place the hub over the jig centerpole. Screw old bolts into the nuts of the hub to protect the screw threads while welding and tighten them to secure the hub.
- 3) Push the 6 wheel clamps over the tire parts
- 4) Clamp the six spokes between each tire clamp and hub.

- 5) Weld the spokes on one side onto the tire clamps. Cool directly after each weld the clamp with plenty of water to avoid burning the rubber.
- 6) Weld the spokes onto the hub. Do this only on the spots between the spokes so the spokes can later on be adjusted.

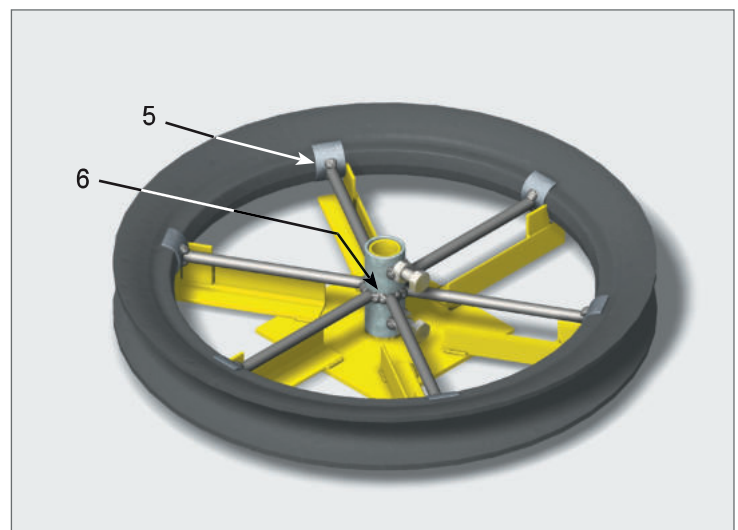

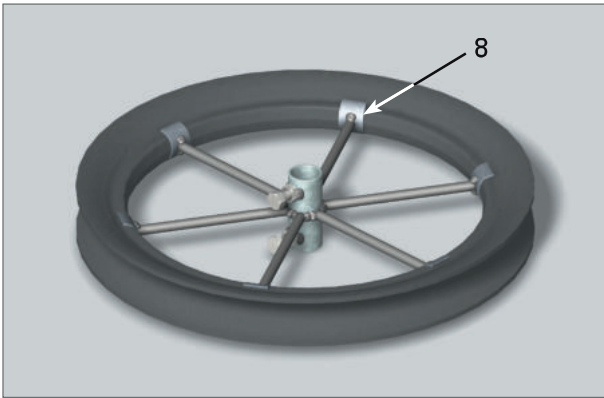

- 7) Separate the wheel carefully from the welding jig.
- 8) The spokes and wheel clamps can now be welded together on the other side.
- 9) Finish the work by replacing the old bolts by new ones.

### **Adjusting the wheel**

Slide the wheel over a 3/4" tube (don't tighten the bolts) and turn the wheel. Probably a wobble in a side motion is visible. Gently hammer on the spokes that cause the wobble to reposition them and so straighten the wheel.

### **Painting**

Paint all the iron parts on the completed wheel to protect it against rusting.



## The handle

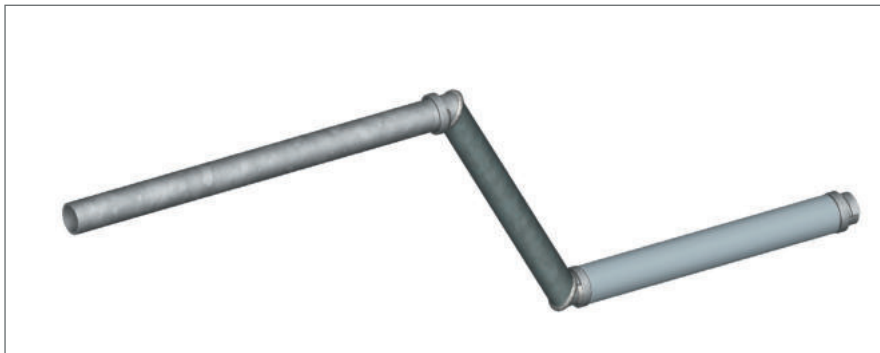

### Sawing the tubes

The handle consists of three parts made of a 3/4" galvanized pipe. Saw the pipe as shown below.

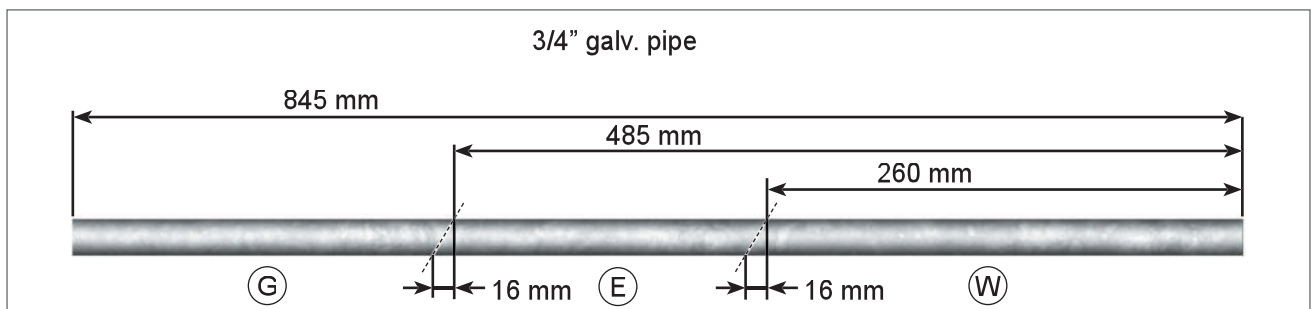

The three different section are marked as follows:

- G) Grip
- E) Eccentric
- G) Wheel side

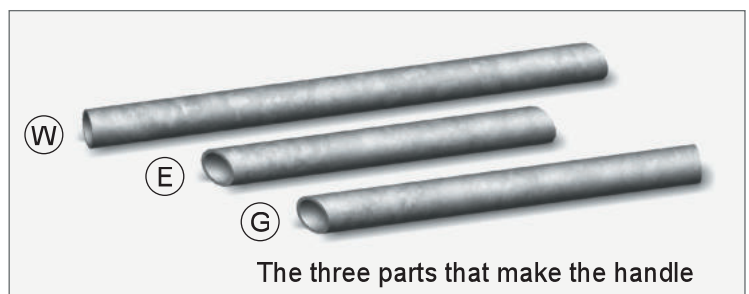

### Welding the tubes

Line up the three tubes on a flat surface as shown in the picture. Use the wooden jig for a correct alignment and secure the tubes with bricks. Weld the tubes together on one side.

The handle jig is described on page 31.

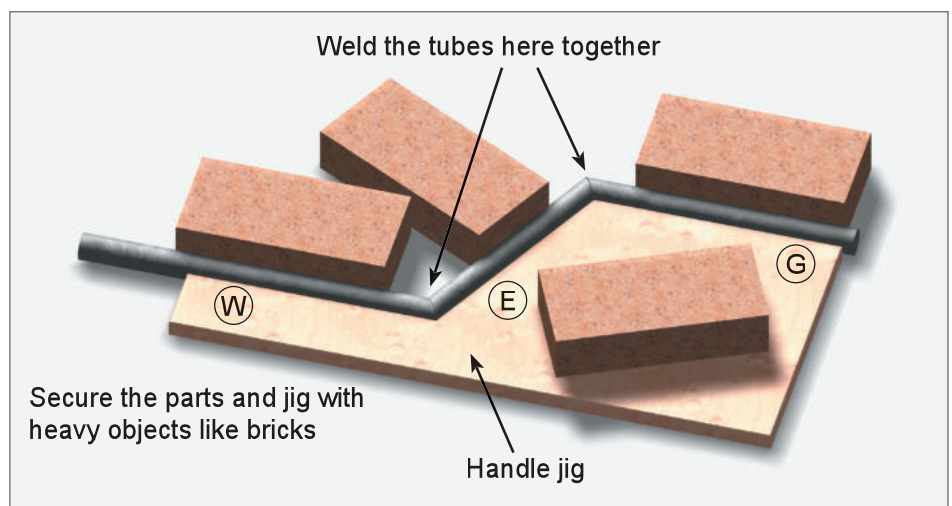

Check the alignment, correct if necessary and weld up the joints on the other side. After that, complete the welding so that all the joints are welded all around. It's very important that the two end tubes are aligned exactly parallel.

### Rings

For a smooth operation of the pump a grip is added. To secure the grip on the handle three rings needed.

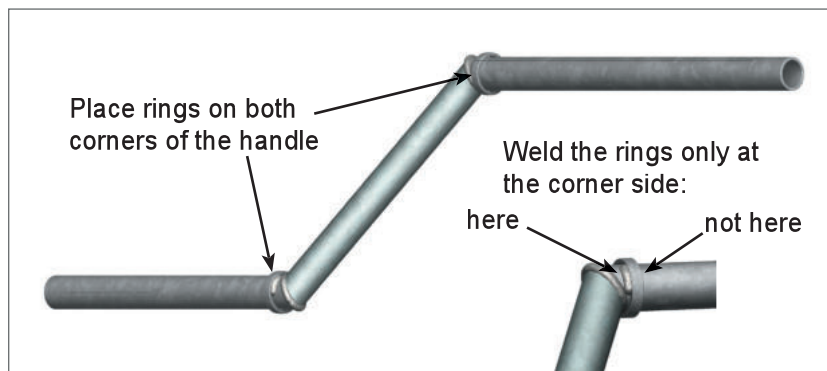

### Locking lugs

One end of the handle pipe marked with "G" must be provided with locking lugs. Pay attention to the saw directions so the lugs will bend open in the right direction. This is to avoid injuring the user.

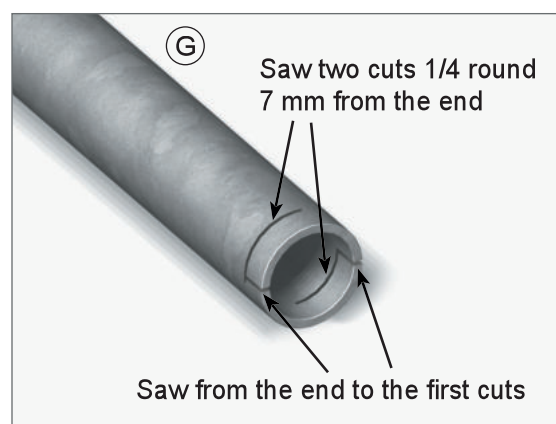

### The grip

The grip is made of a PVC pipe. The inner diameter of the pipe has to be wide enough to easily slide over the handle tubes, but small enough to avoid rattling too much.

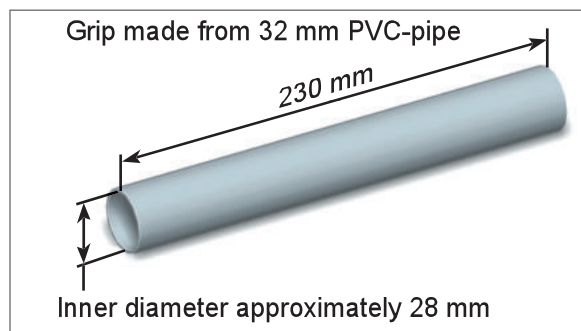

### Locking the grip

The PVC grip is locked into place with the third ring and by bending the locking lugs a little bit outward.

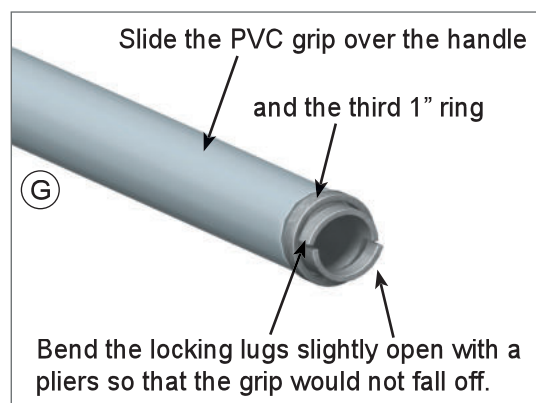

## The frame

The frame is shown in the drawing below. All the part required to construct the frame are described in the following paragraphs.

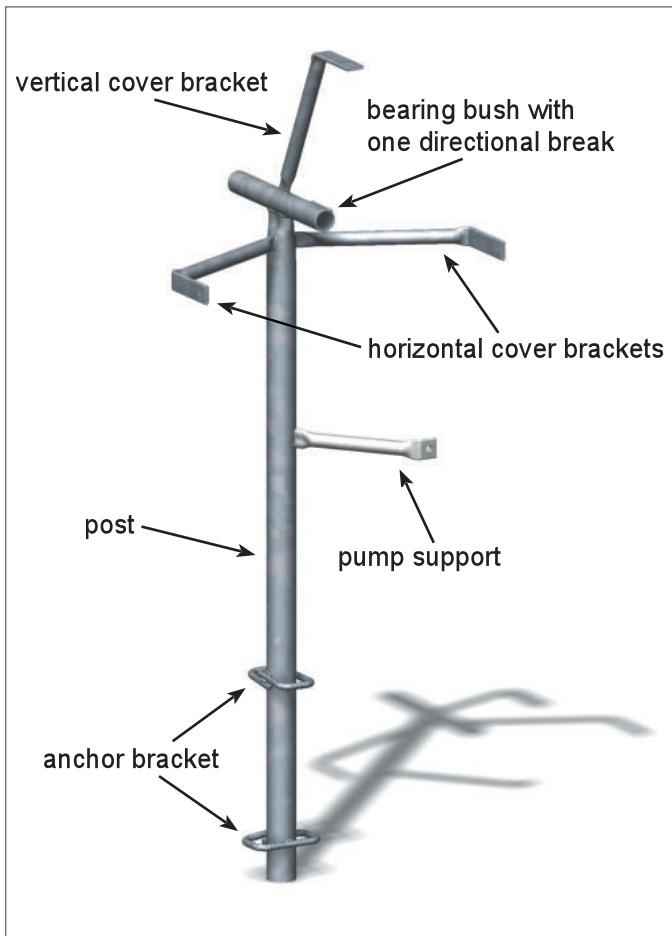

## Post

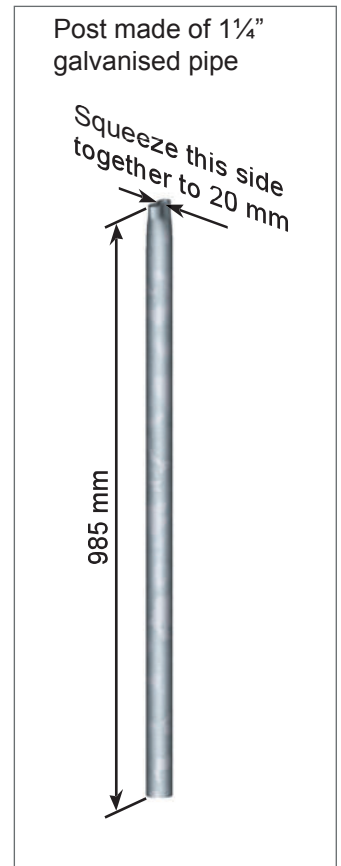

## Bearing bush

The bearing bush has an integrated one direction break. Therefore the pipe needs some modifications.

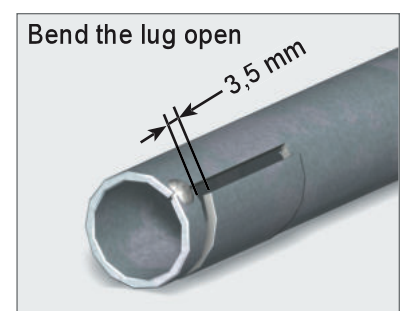
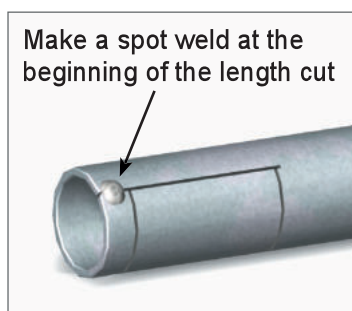
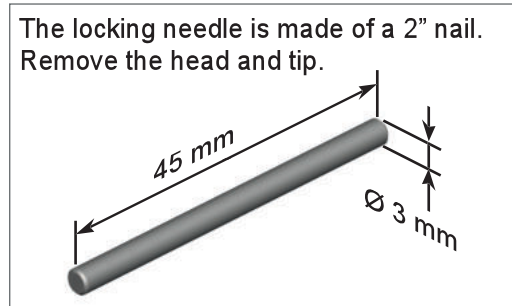
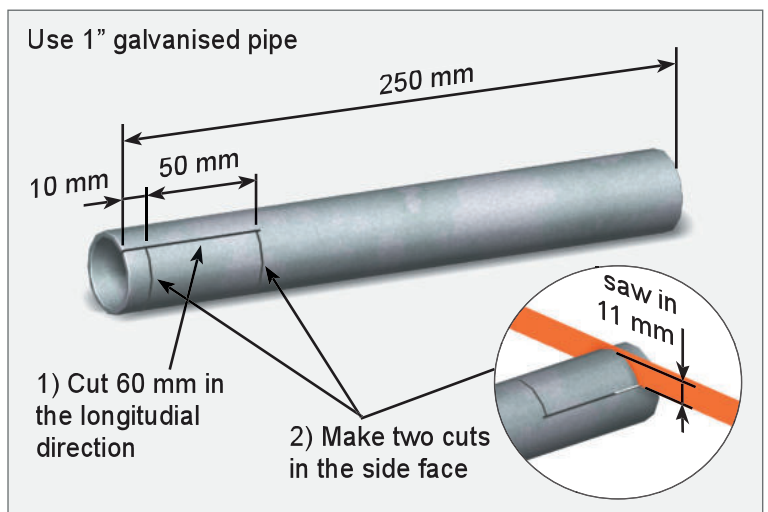
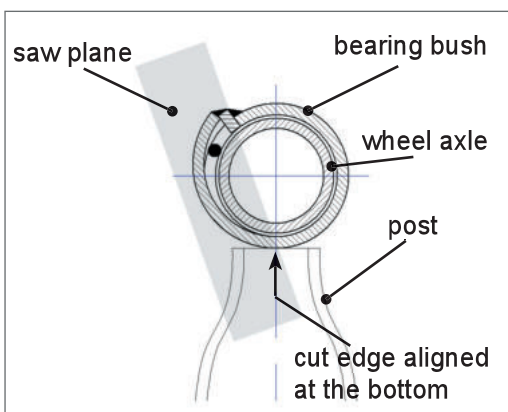

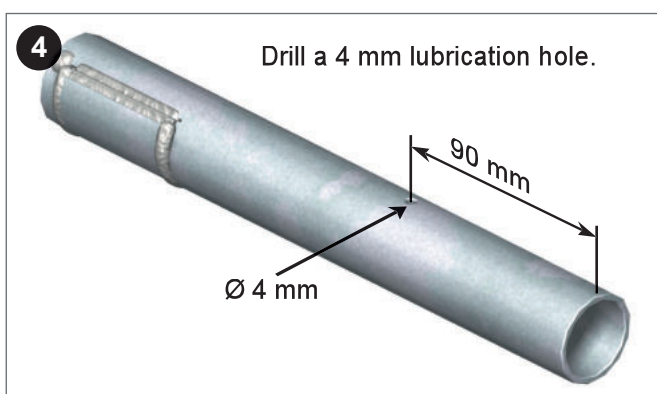
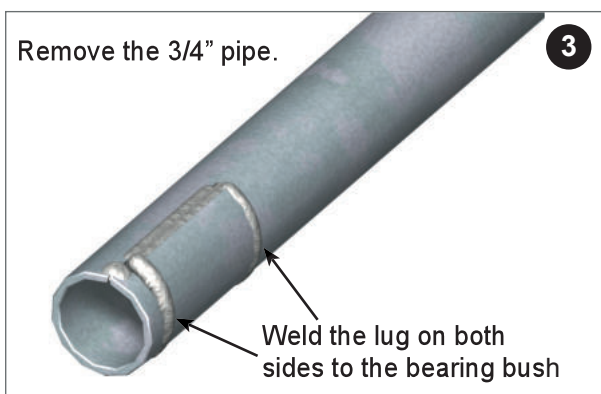
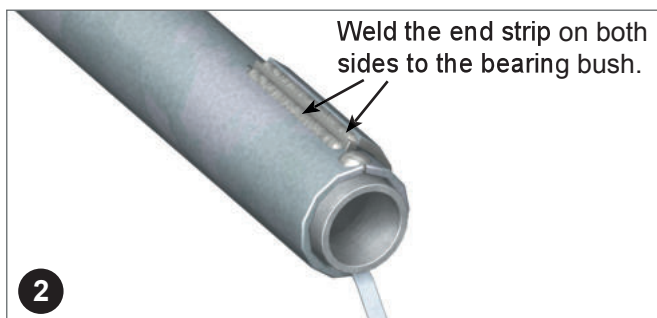
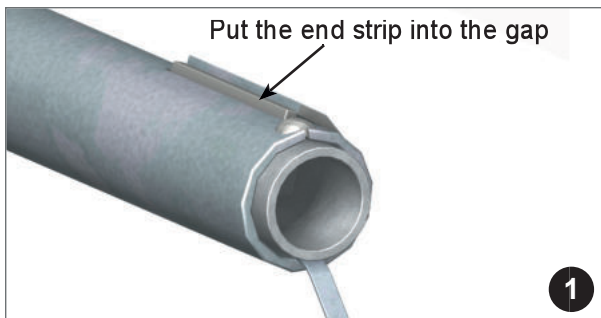
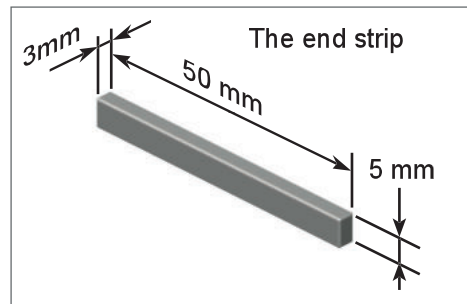
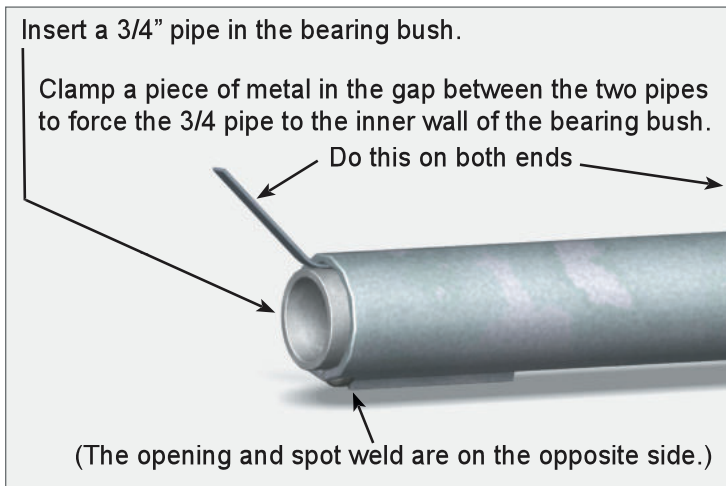

### Welding the bushing to the frame

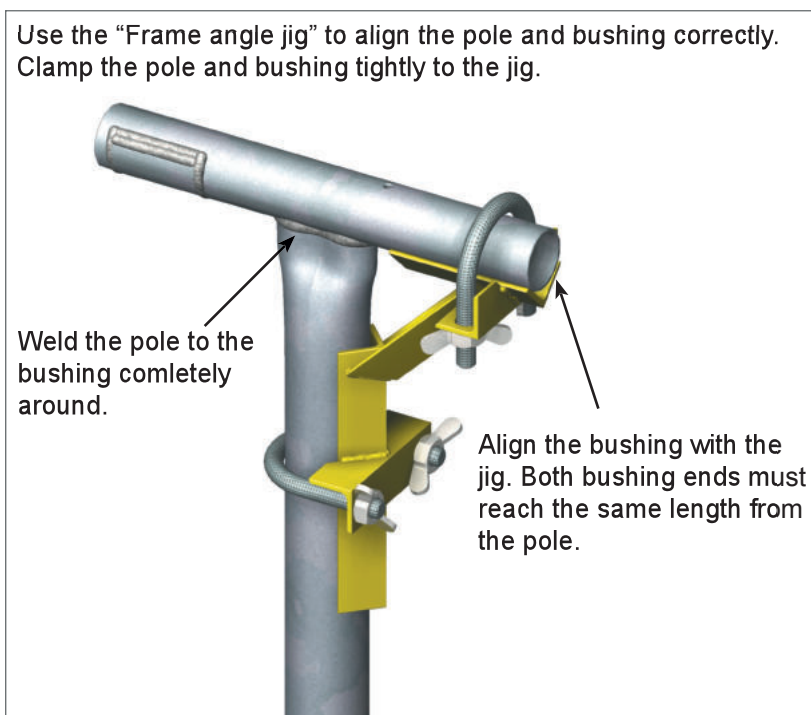

Make sure that bearing bush is positioned with the right angle onto the post. The start of the lug must point to the bottom side.

The used frame angle jig is described on page 32.

### Vertical cover bracket

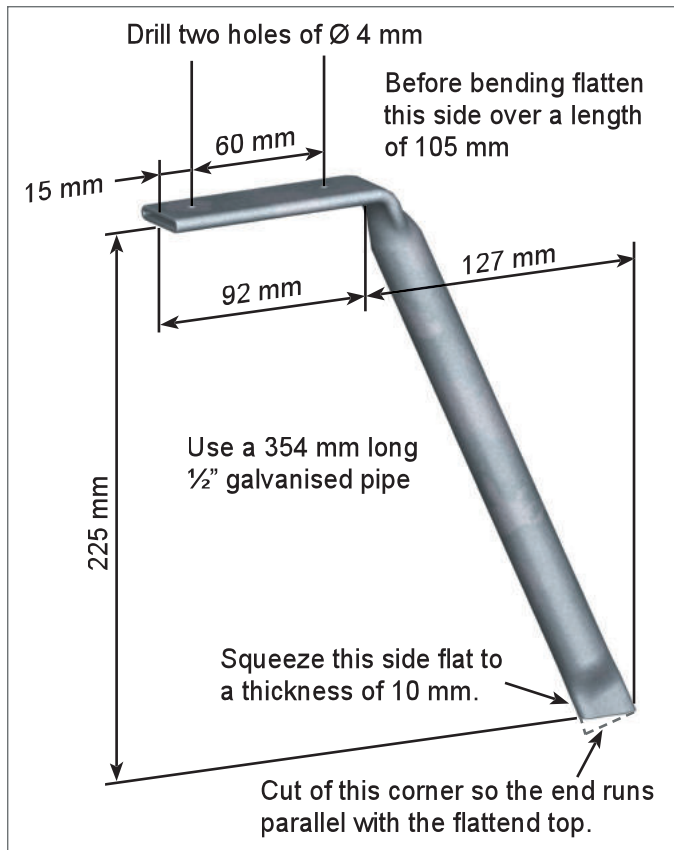

Check the bend angle of the vertical and horizontal cover brackets with the "cover bracket bend jig".

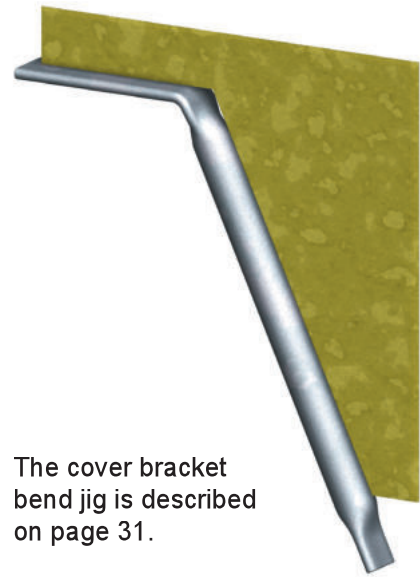

The cover bracket bend jig is described on page 31.

### Horizontal cover bracket

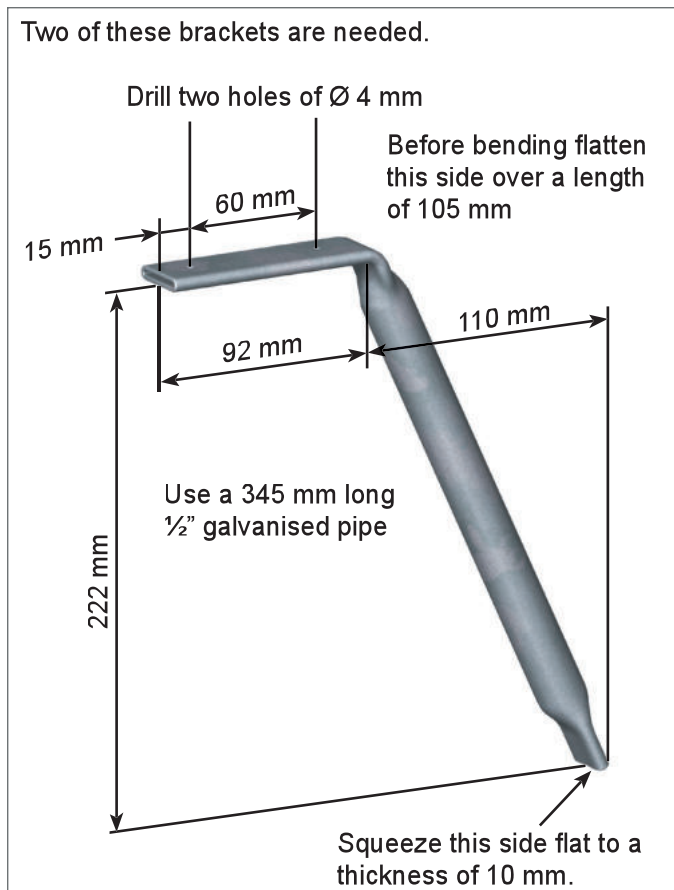

## Welding the cover brackets

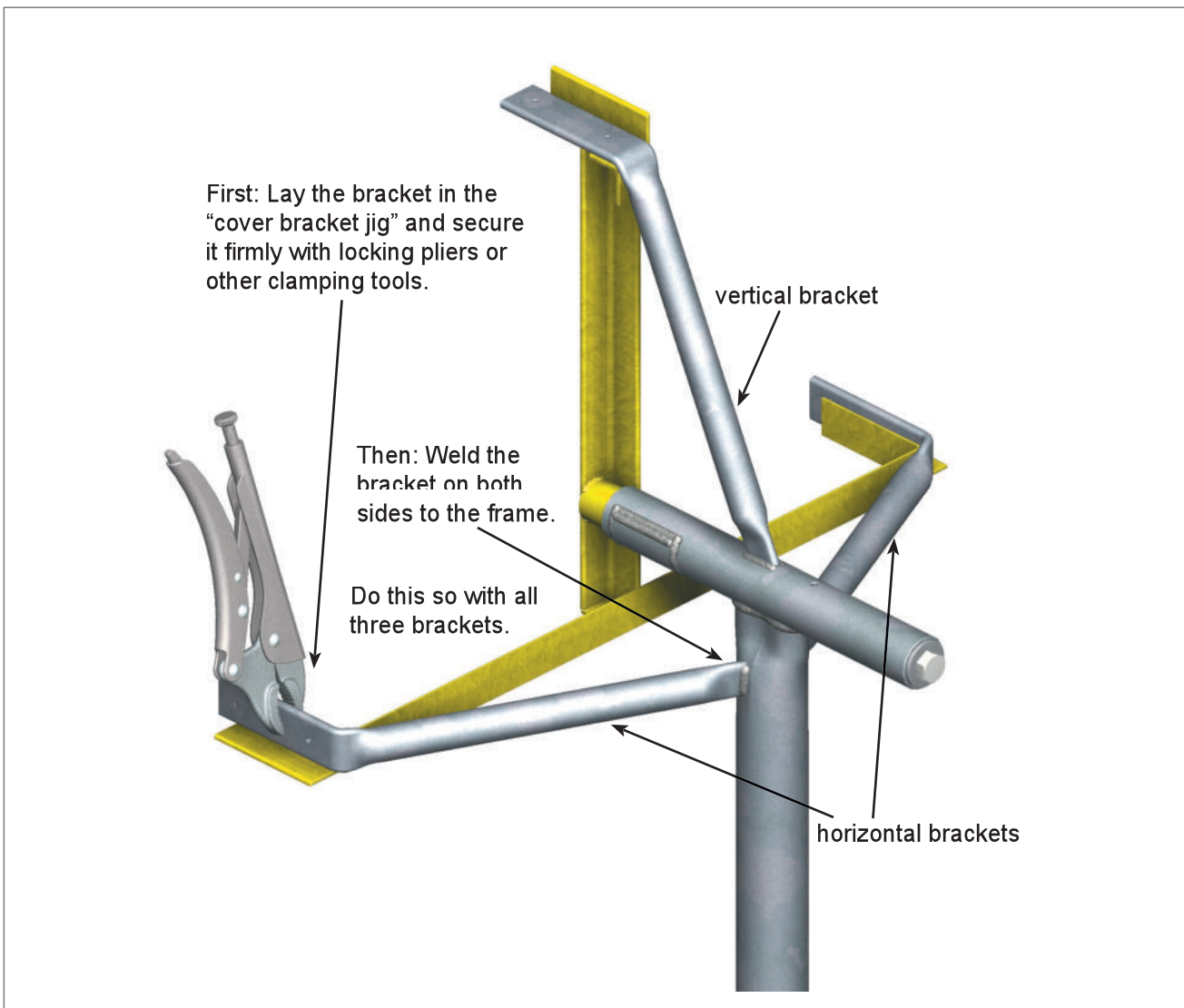
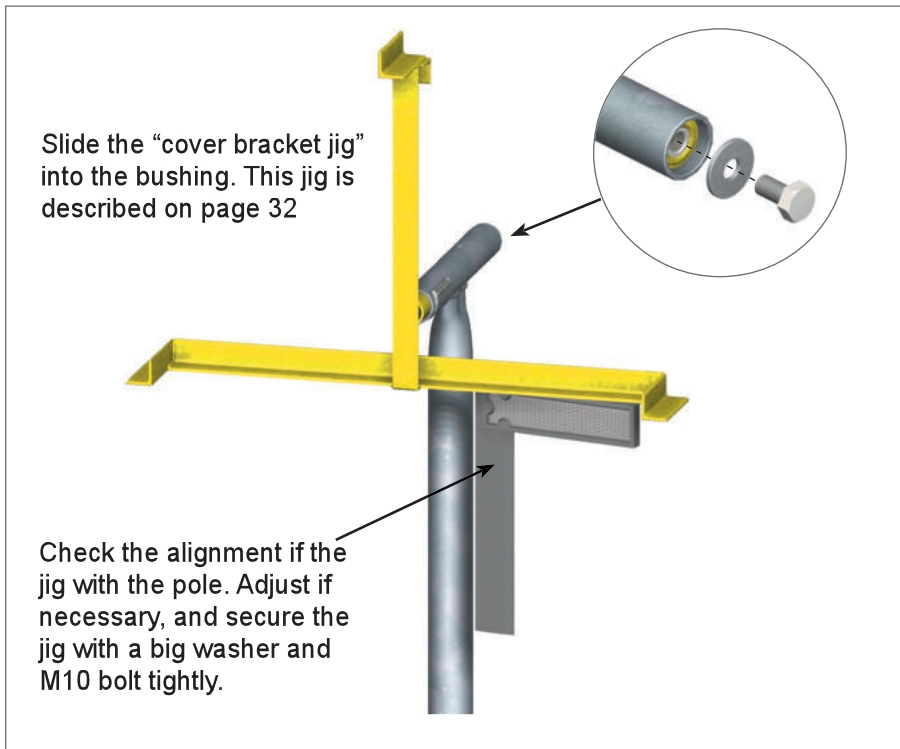

### Anchor bracket

Two anchors are required, made of a 290 mm long  $\text{Ø}10$  mm reinforcement bar.

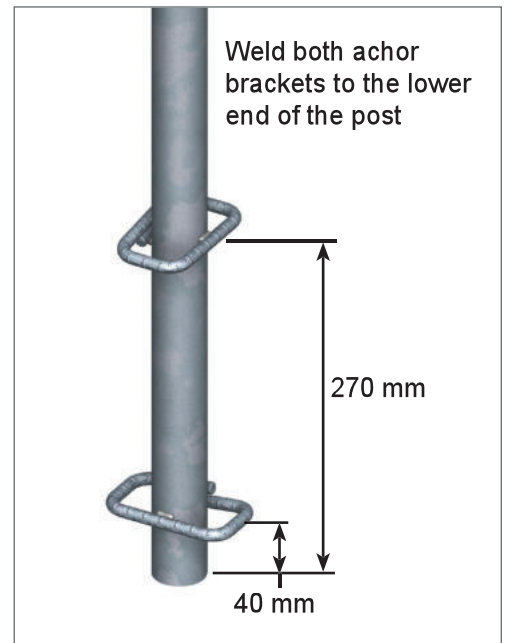
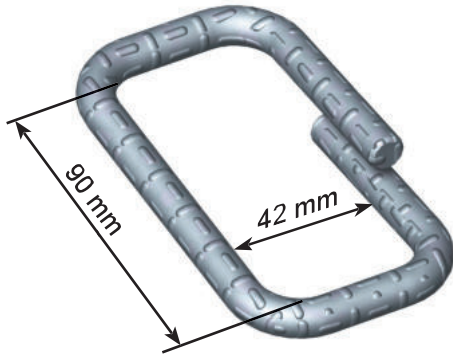

## Pump support arm

The pump support arm is made of a 215 mm long 1/2" galvanised pipe.

Flatten this side over a length of 35 mm. Then bend this end. Check the bend angle with the "pump support bend jig" described on page 31.

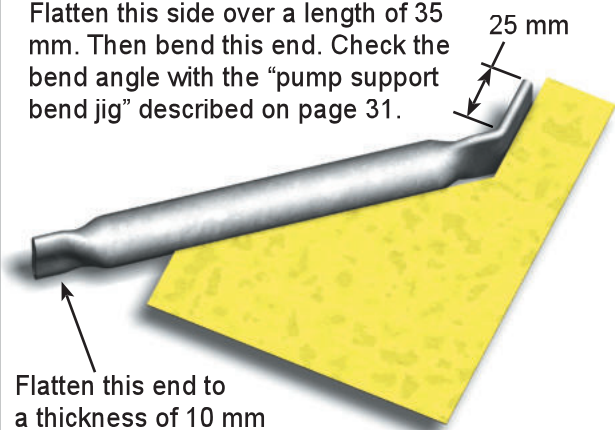

Flatten this end to a thickness of 10 mm

Drill a hole in the bended flat piece.

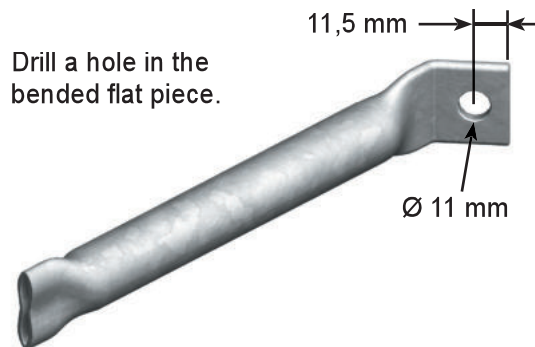

Weld a M10 nut on one side above the hole.



## Mounting the pump support arm

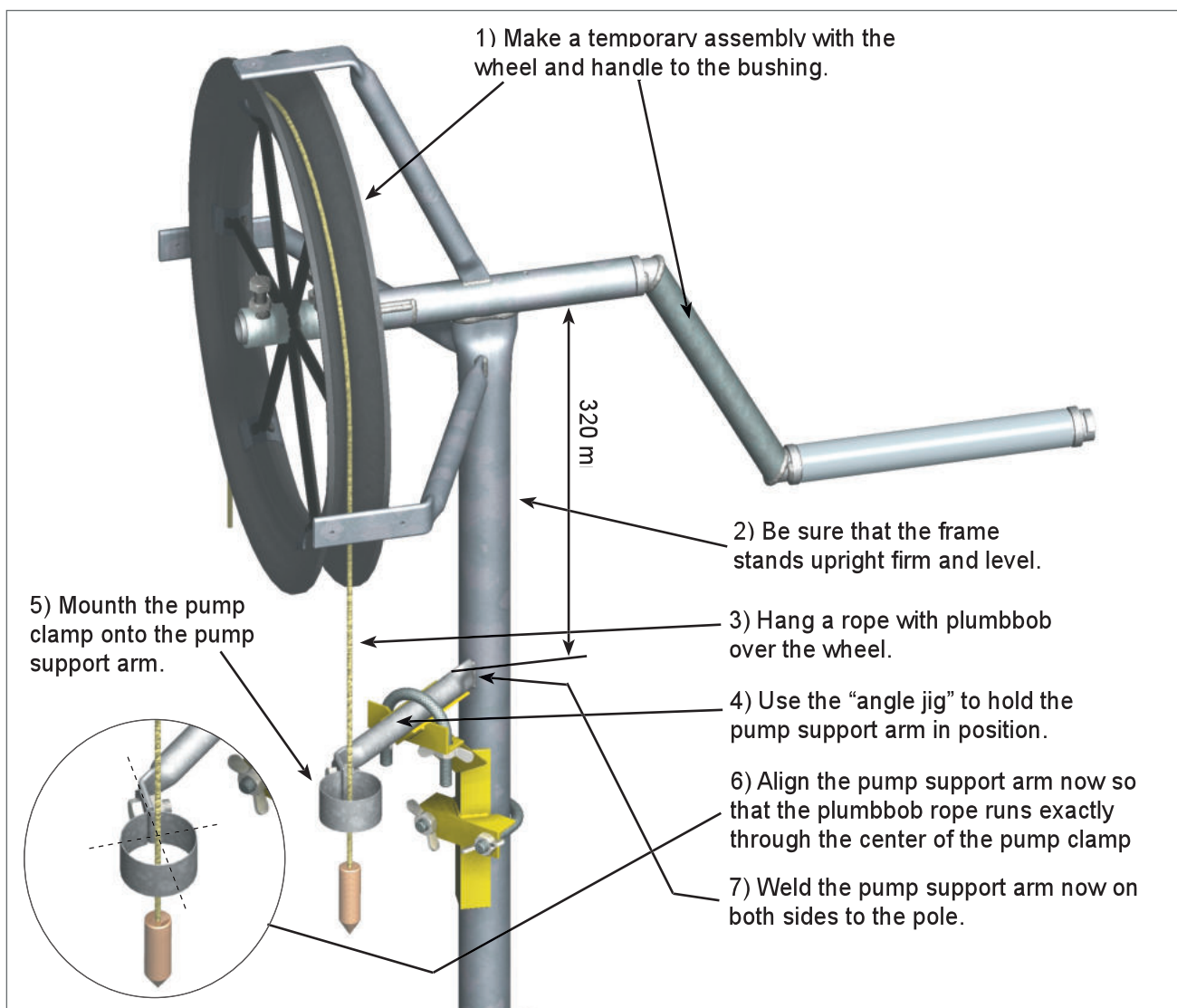

## Painting the frame

All the welding on the frame is now done. Clean the frame thoroughly from dust and grease. Only the bare parts that not are protected by zinc have to be painted.



## The wheel cover

The cover is made of 0,7 mm thick gavanized sheet 200 mm width and 1000 mm long.

Mark out the sheet with the given dimensions.

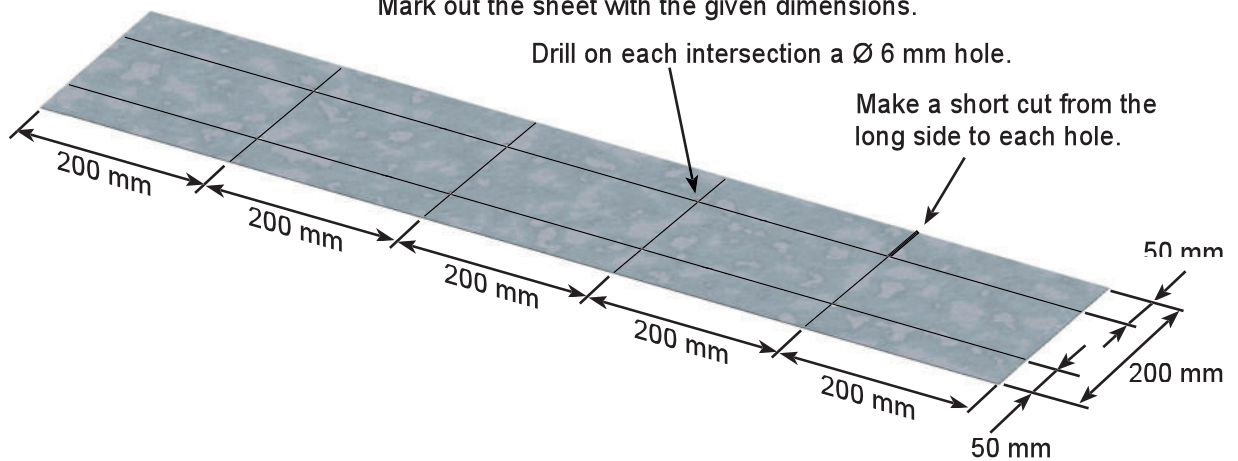

Fold the edges, on the both long sides as well on the short side double to avoid sharp edges.

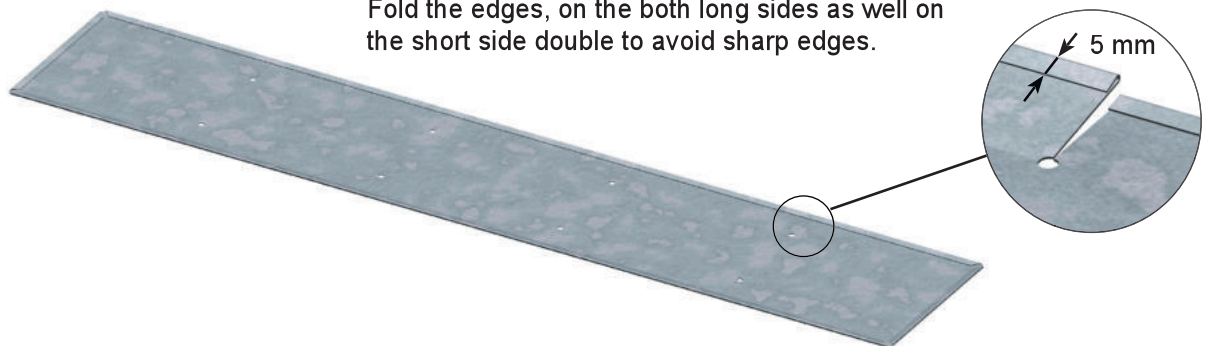

Fold the long side aligned to drilled holes.

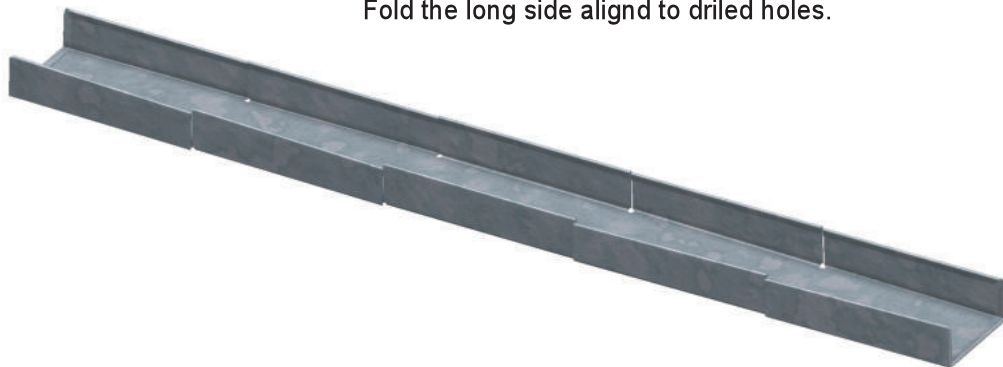

The last bends makes it a cover.

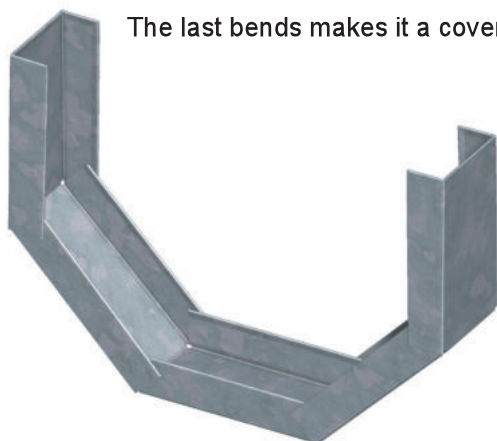

Drill a  $\varnothing 4$  mm hole on each corner and rivet the flanges together.

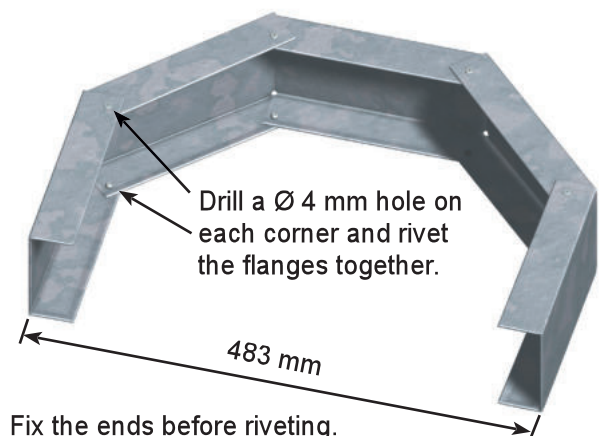

## Frame assembly

### Mounting the cover

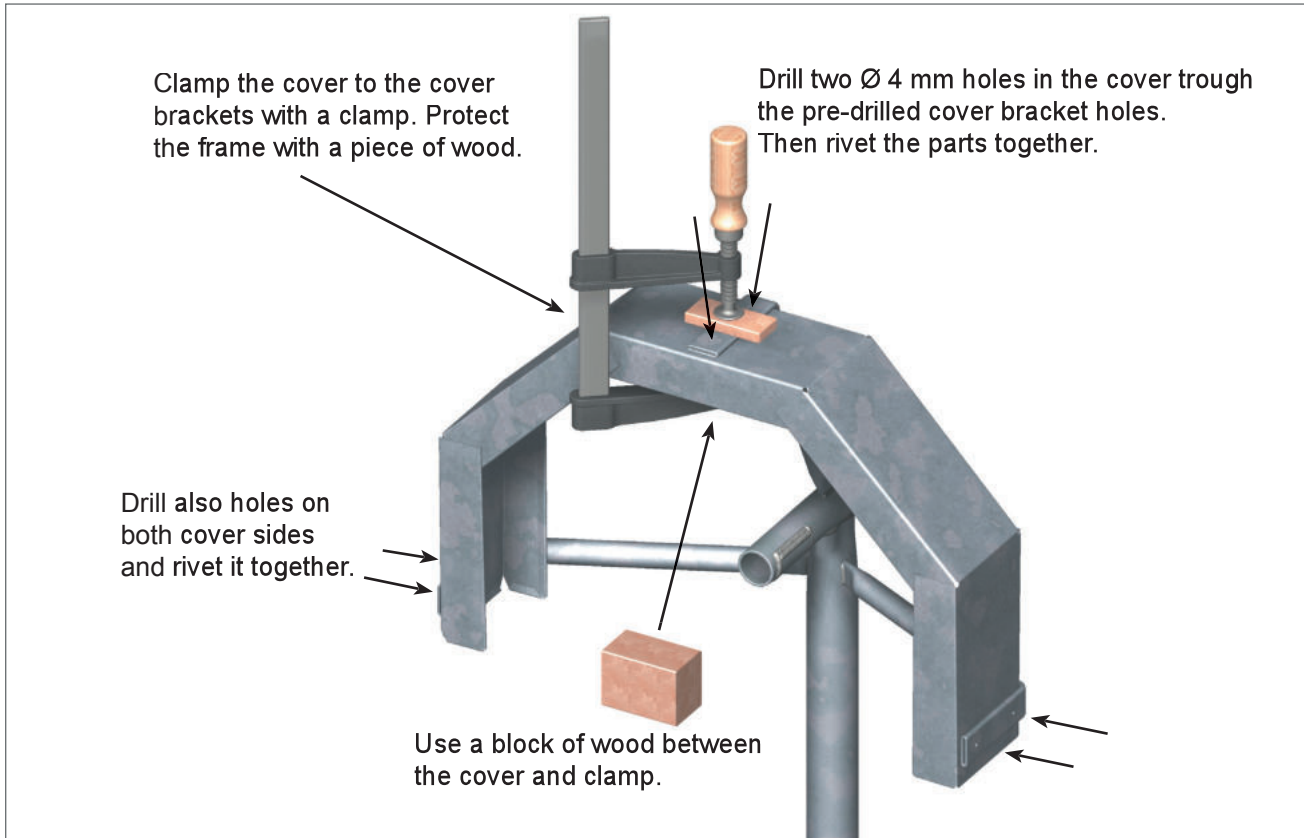

### Mounting the handle

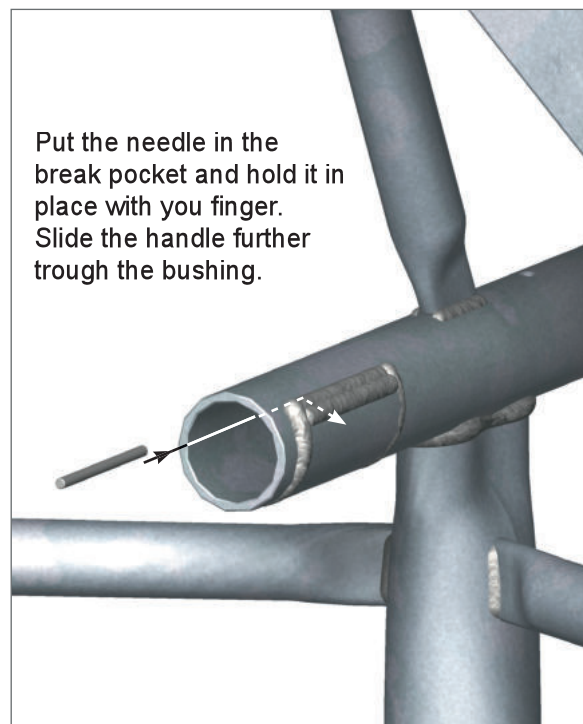
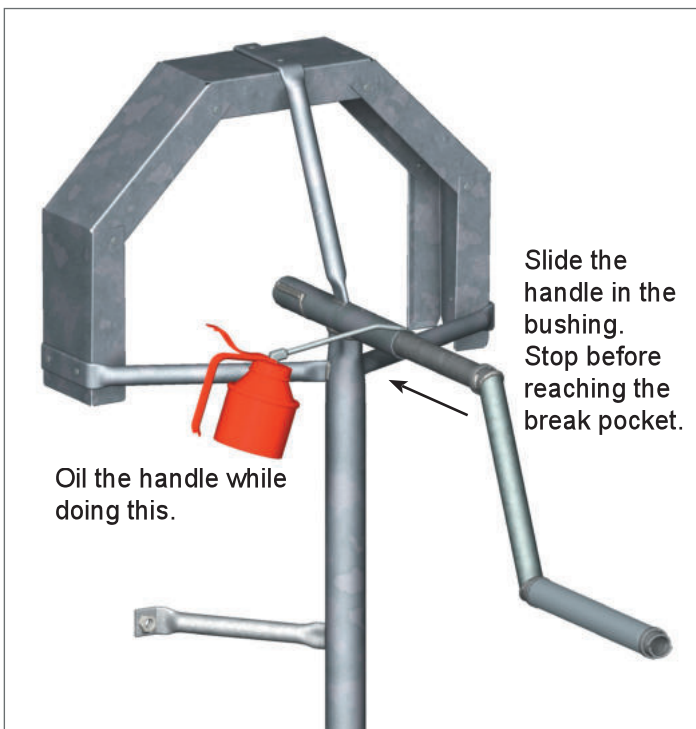

### Wheel assembly

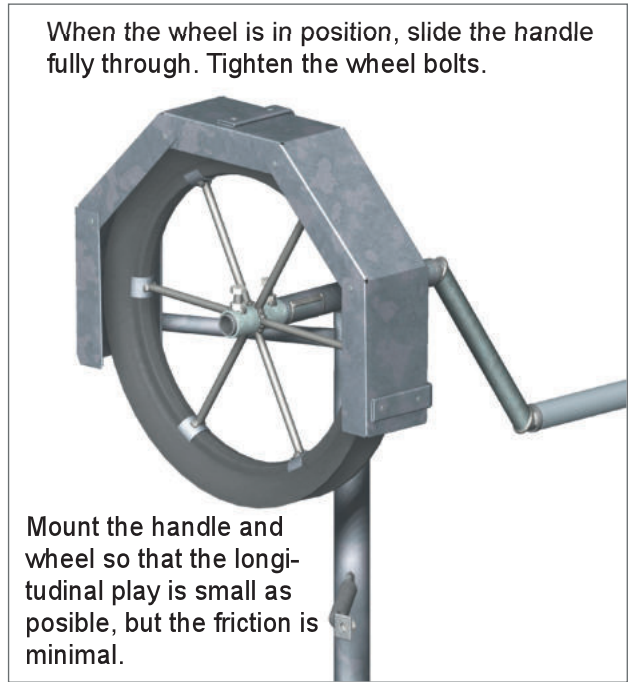
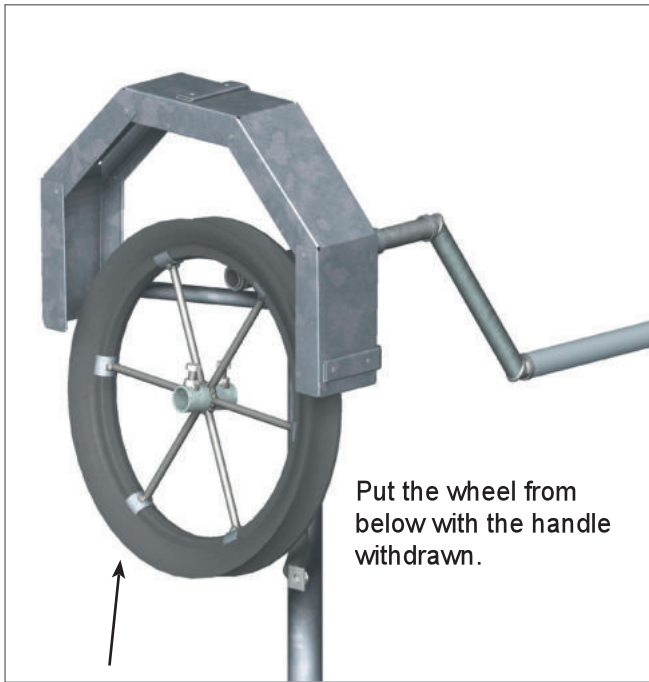

### Bore hole cover

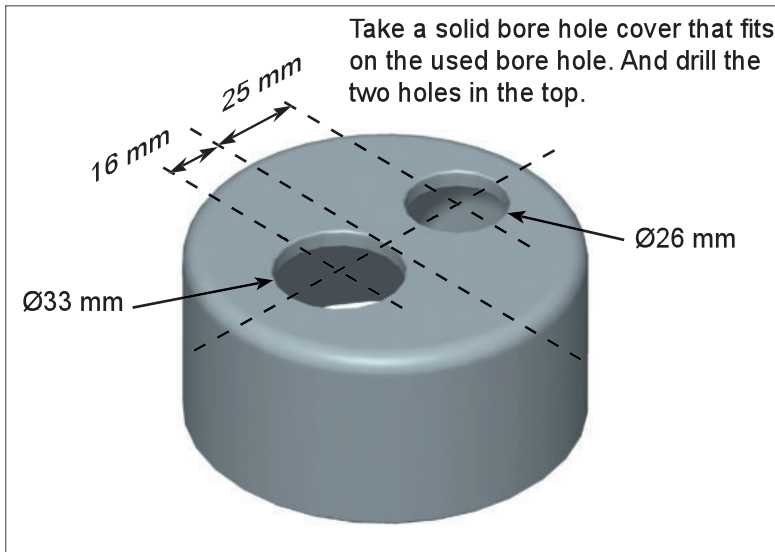

Given measurements are for a Ø25 mm rising main and a Ø32 mm return pipe.

### Pump clamp

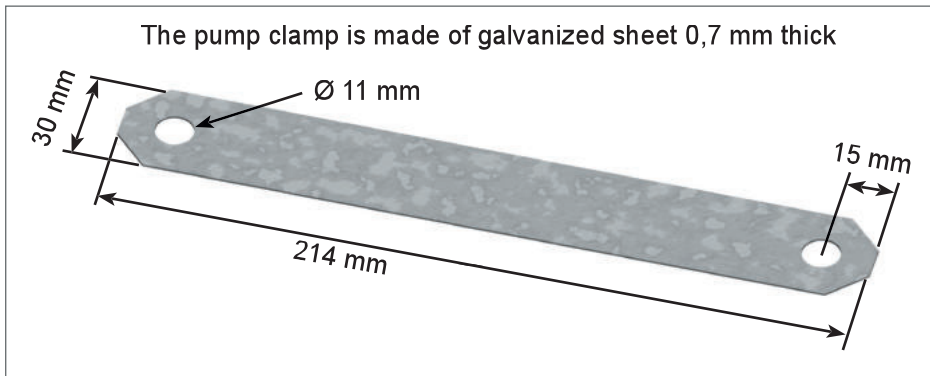

The given measurements are for a Ø40 mm return pipe. Adapt the measurements for other pipe diameters.

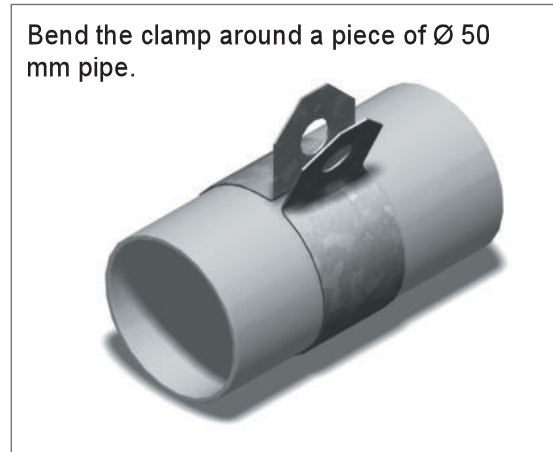
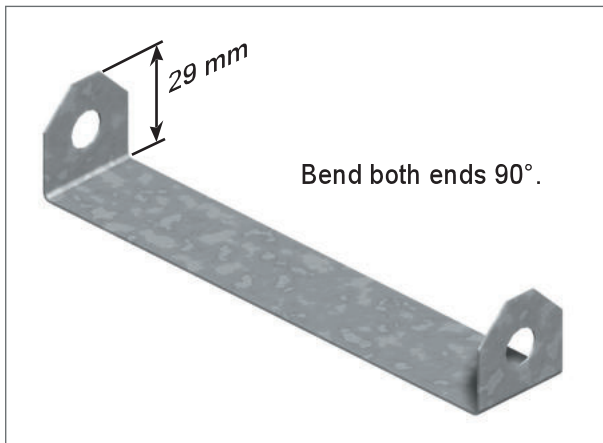

### Return tube clamp

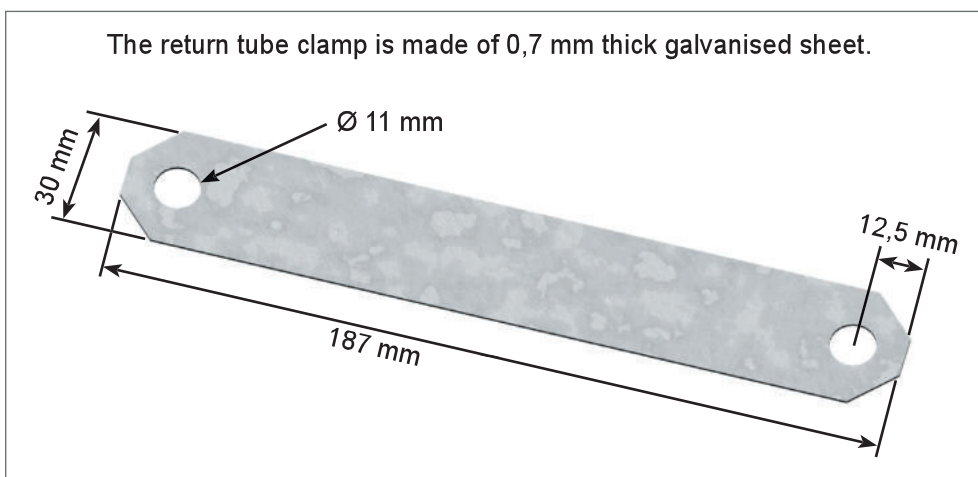

The given measurements are for a Ø32 mm return tube clamp. Adapt the measurements for other pipe diameters.

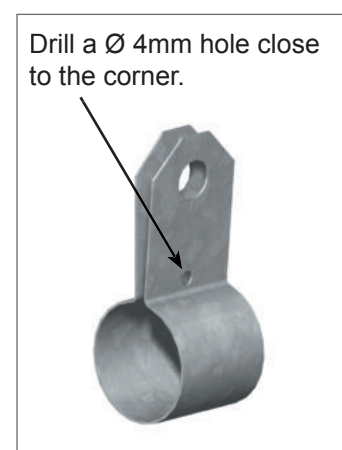
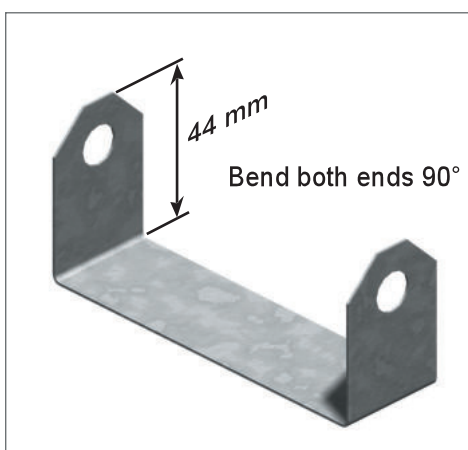

# Frame installation

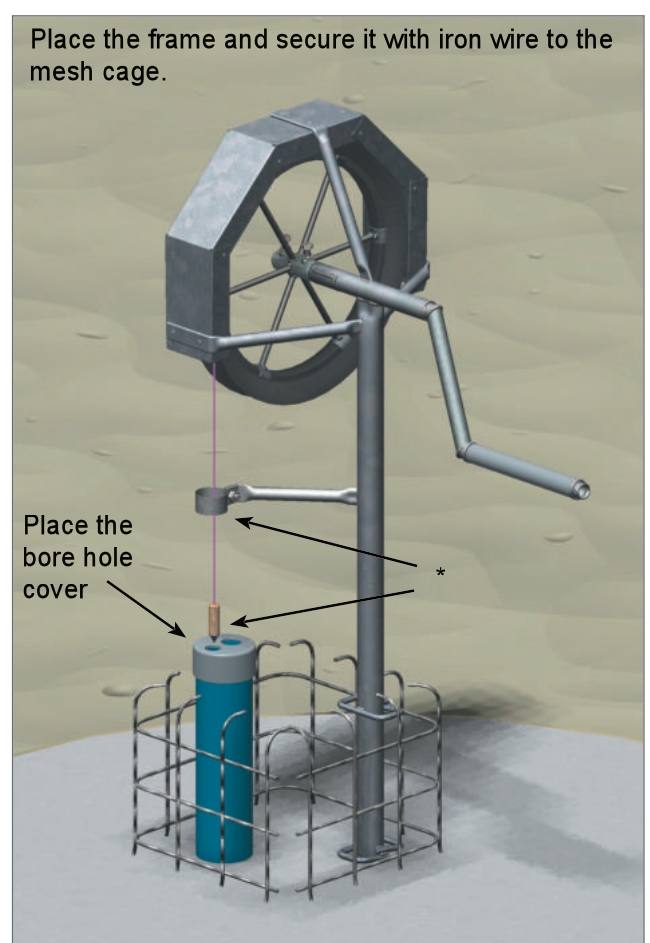
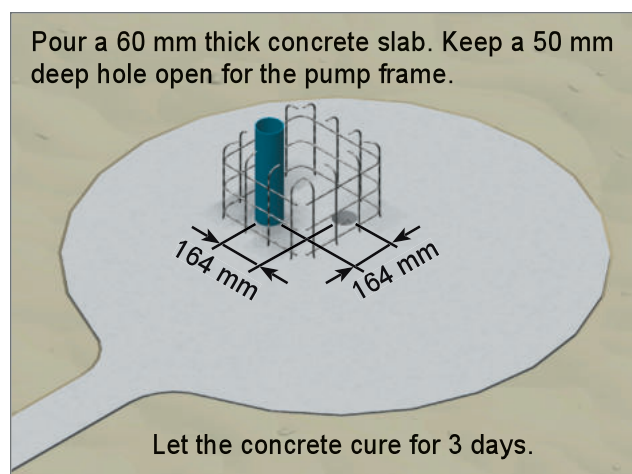
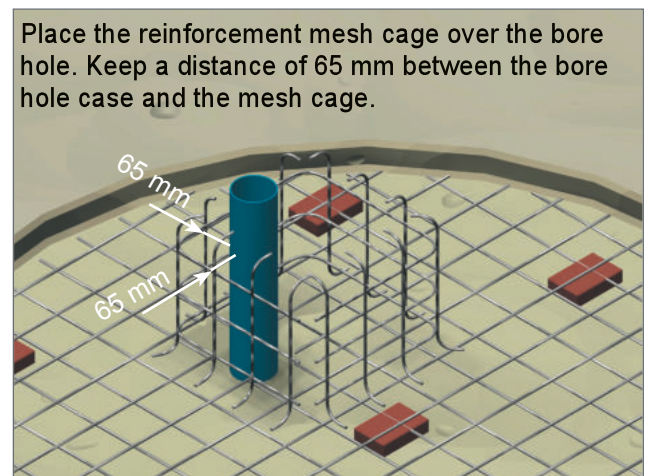
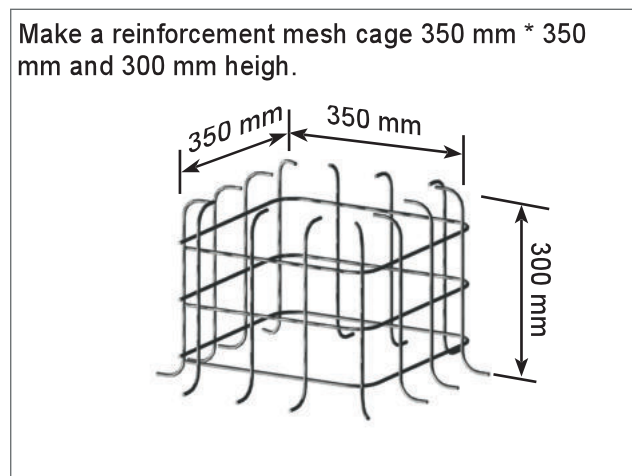
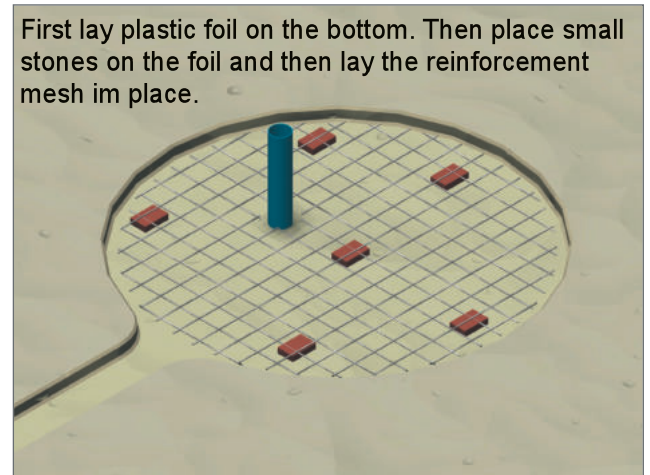
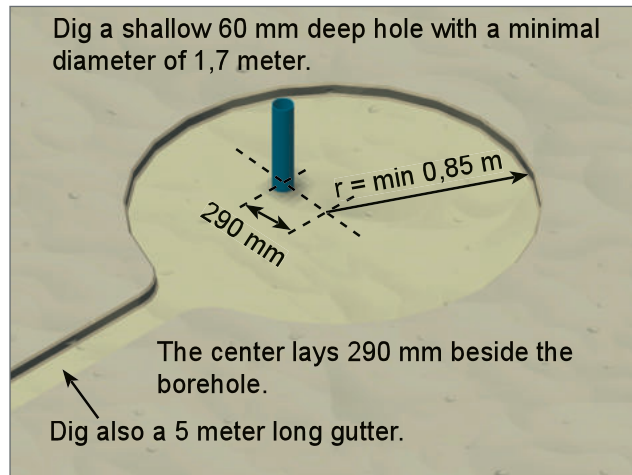

\*) When the pump is placed waterlevel the plumbbob must go though the pump support center and hangs above the small cover hole.

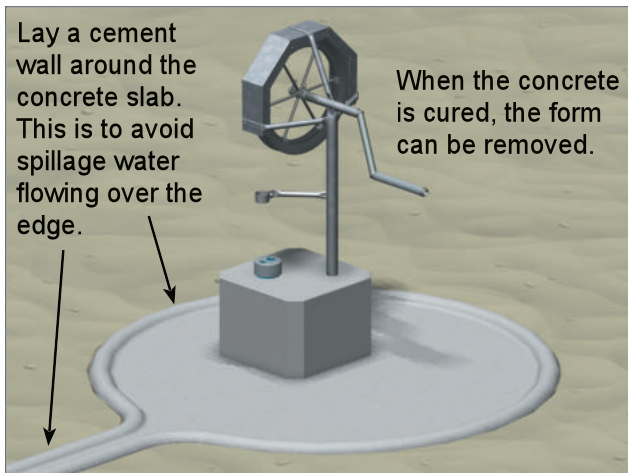
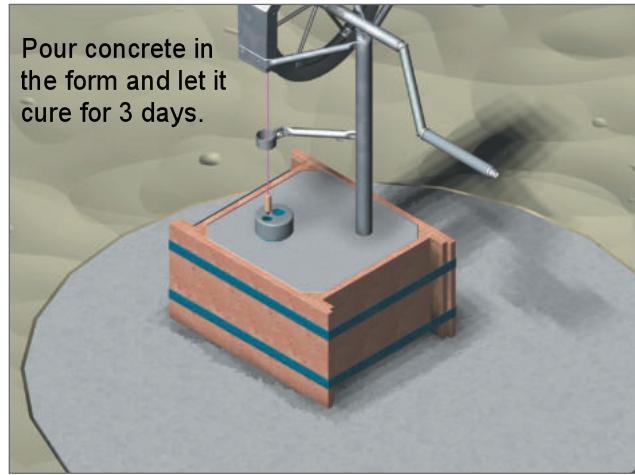
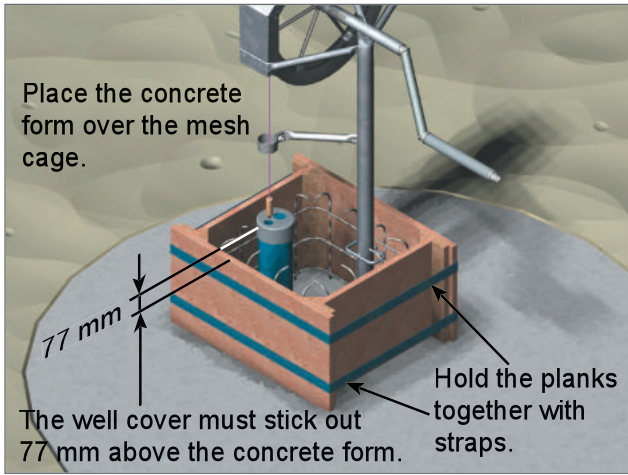

# The pump

(25 mm rising main example)

The pump is the actual part that lifts the water and is located mainly in the borehole or well. It consists of the PVC construction with the rising main, the inlet guide and the outlet construction. And secondary the rope with the pistons.

## Rising main

The diameter of the rising main depends on the water lifting height. Choose the tube diameter from the table under section "Pump capacity" on page 4.

## Making a flare

The lower end of the rising main must have a flare so the pistons will easily slide in the pipe.

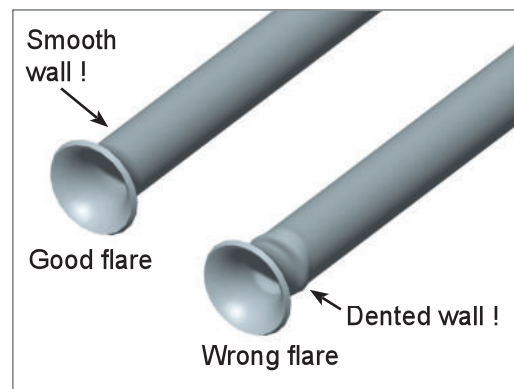
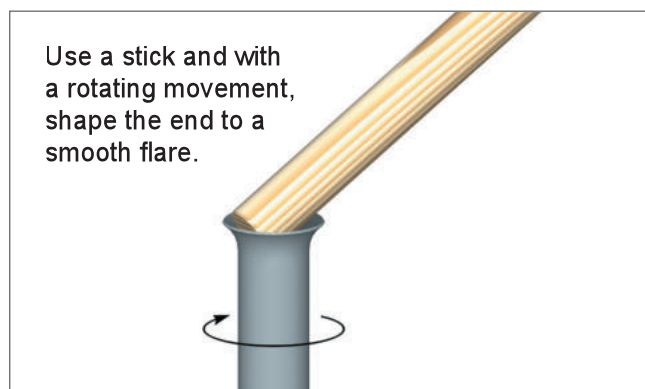
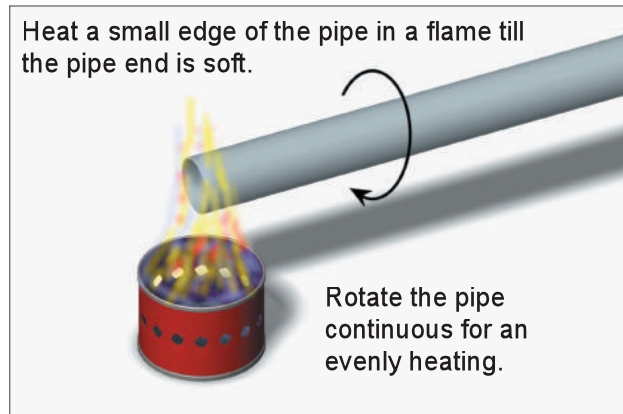
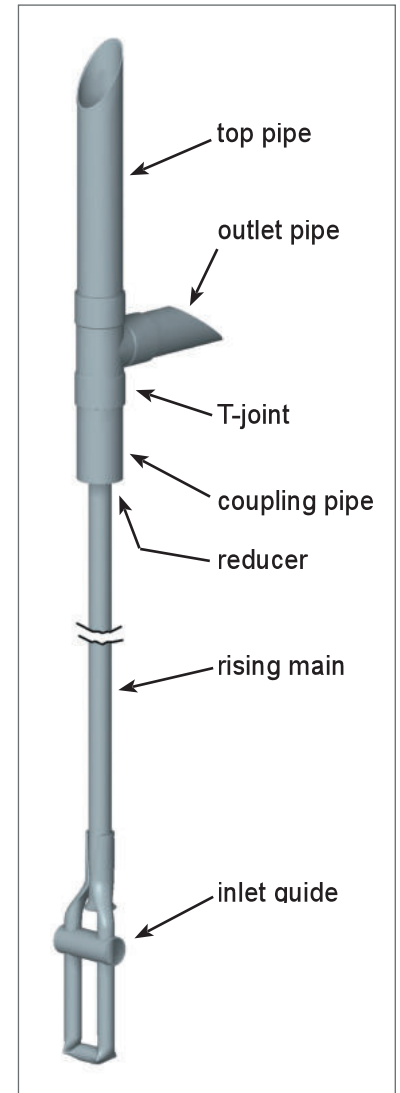

## The inlet guide

The inlet guide ensures that the rope with the pistons smoothly enters the rising main. The given dimensions concern only the 25 mm rising main.

## The inlet bracket

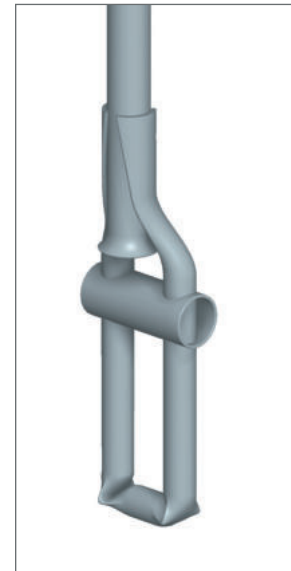
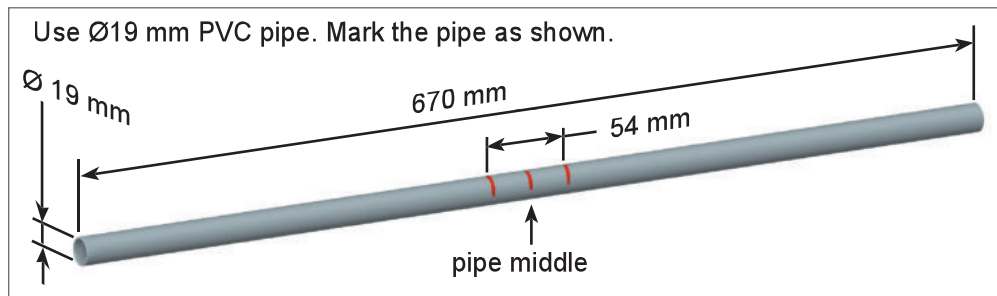

Nod the pipe at the marked places.

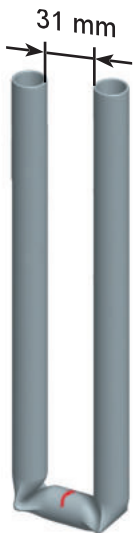

Warm the nod places a little bit, but don't soften them!

## Rope guide

The length of rope guide must fit in the borehole diameter.

The rope guide is made of a Ø32 mm PVC pipe, ca. 80 mm long.

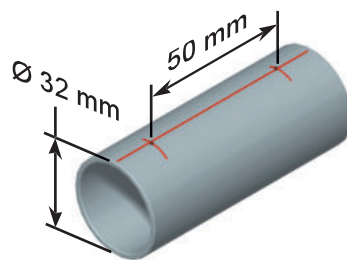

Make two holes at the marked places trough both, the top and bottom side.

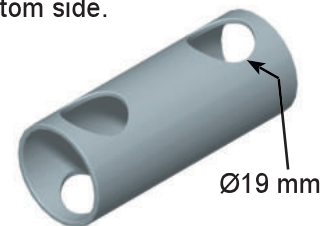

## Inlet guide assembly

Slide the rope guide over the two inlet bracket legs.

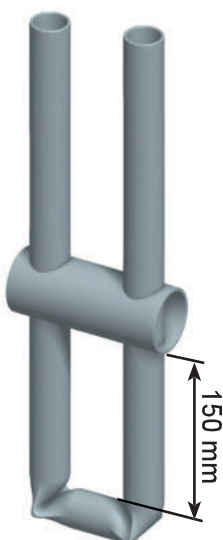

Heat both inlet bracket legs simultaneously until they feel soft over the full length.

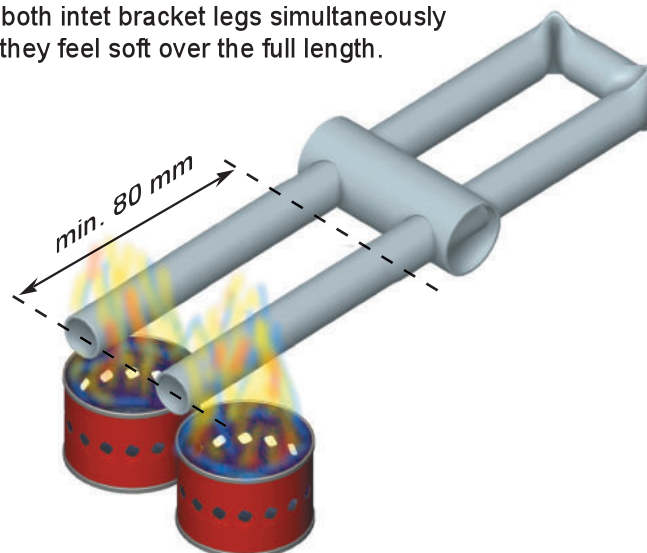



While the inlet guide brackets legs are still warm and soft squeeze them to the flared rising main. Wear gloves for heat protection.

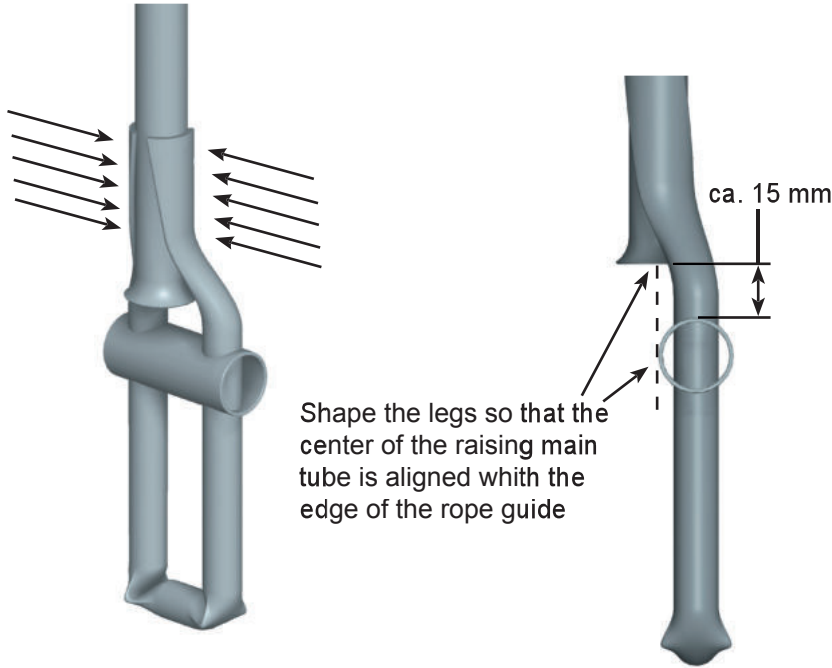

After the shaping of the inlet guide bracket legs, they can be glued to the raising main. Sand the adjoining faces before.

Wrap rubber strips around the glued parts so there are pressed to each other firmly.

### Top and outlet pipes

The top and outlet pipes are made of  $\text{Ø}50$  mm PVC pipe. Take a 395 mm long pipe and saw this diagonal in two parts as shown.

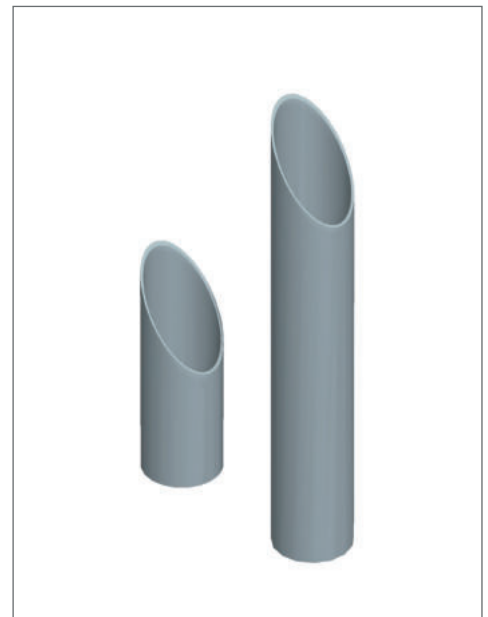
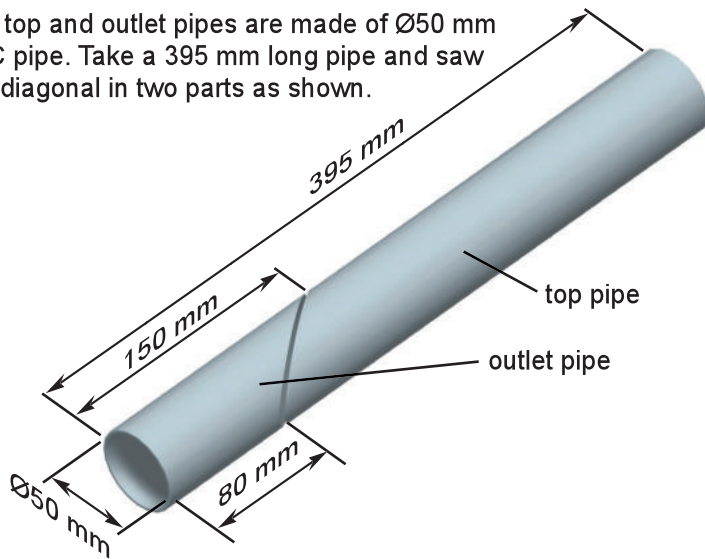

### Reduction

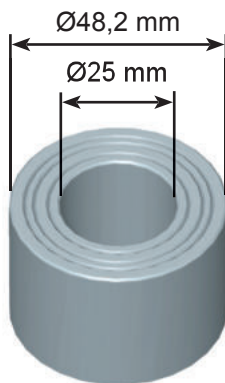

To couple the  $\text{Ø}25$  mm rising main to the  $\text{Ø}50$  mm coupling tube, a reduction is needed. Assemble this from different pipe sizes.

### Coupling pipe

The coupling pipe is made of  $\text{Ø}50$  mm, 117 mm long PVC pipe.

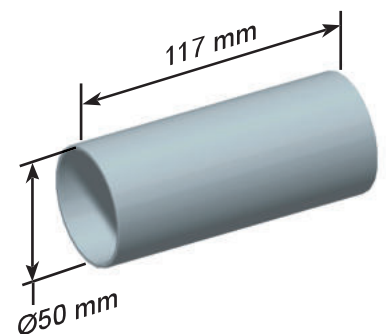

## Return tube

The used return tube jig is described on page 33.

Prepare the return tube jig.

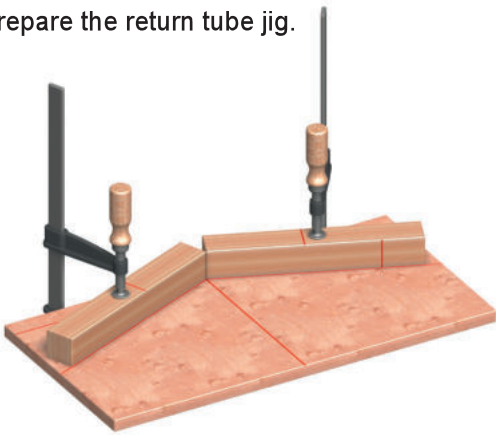

The return tube is made of a 620 mm long  $\text{Ø}32$  mm PVC pipe.

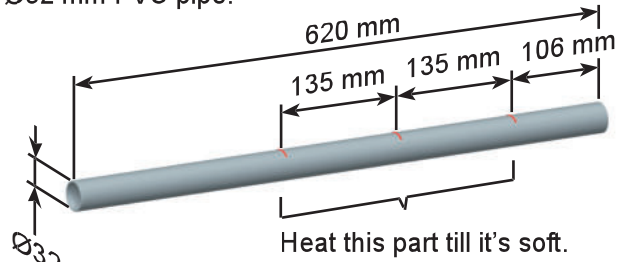

Place before heating on both ends airtight endcaps. The generated inner pressure by heating will prevent buckling of the pipe.

Lay the softend pipe in the jig.

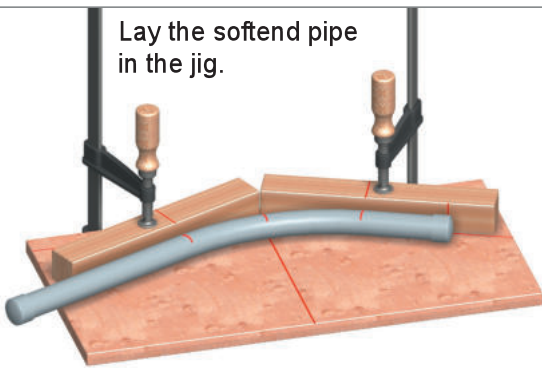

Cool the made bend with water.

Put the return pipe in the biggest hole of the bore hole cover. Now flare both ends as shown before the rising main.

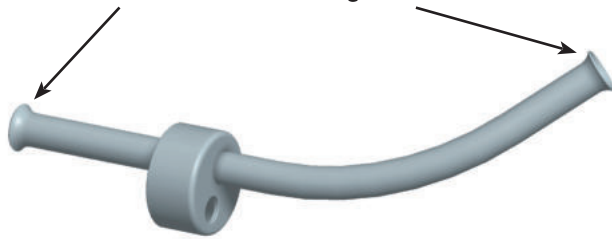

Put the return pipe clamp on the return pipe and put a rivet in the small hole.

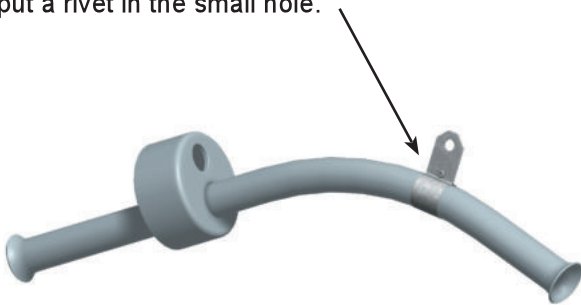

# Pump installation

## Pistons

The best pistons are the molded HDPE ones. They have the best wear resistance and the best fitting in the main raising pipe. But to make those pistons special equipment is needed. With more basic techniques pistons can be made from the remaining car tire material that is used for making the wheel.

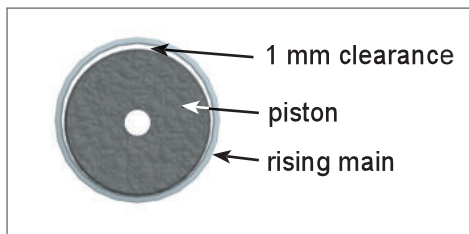

It's important that the pistons can slide easily trough the rising main. Therefore the pistons must have a slightly smaller diameter than the inner diameter of the rising main. A clearance between 0,5 and 1 mm is sufficient.

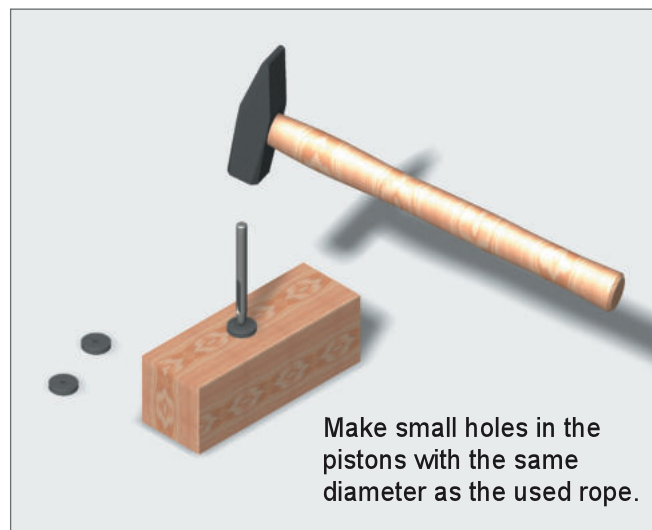
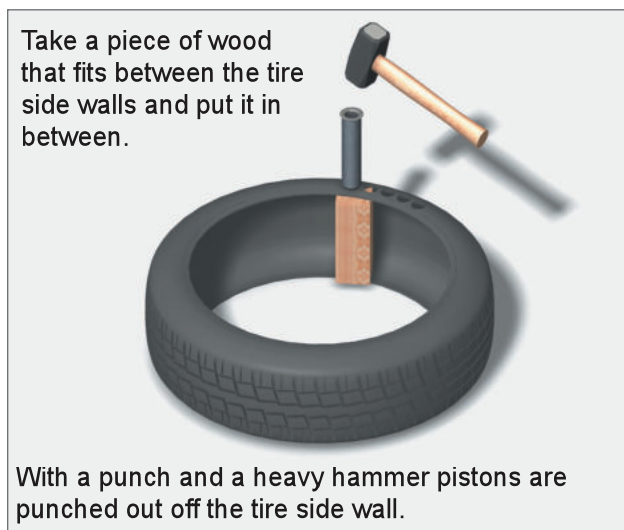

## Rope

Use only plastic rope with a diameter of Ø 4 mm. Organic rope will decompose and therefore it won't last long and can pollute the water. The required length of the rope can be calculated as:

$$\text{rope length [meters]} = (\text{well depth} + 1) * 2,2$$

## Mounting pistons on the rope

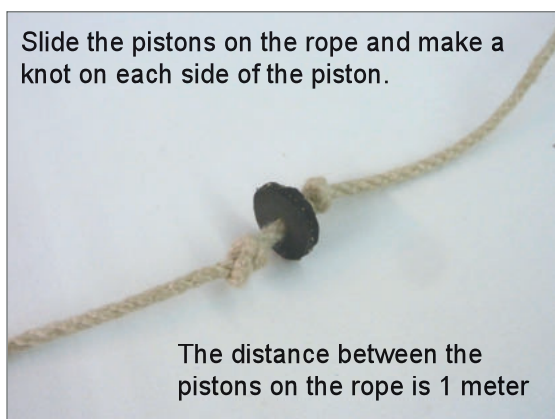

## The rising main

The rising main including the inlet block must reach from the bottom of the well till the top of the bore hole casing. To obtain this rising main length, more PVC-pipes must be coupled together. This is done by making a sock on the bottom side of each extending pipe and glue them together.

For a smooth sliding of the pistons through the pipes it's important that the sock is made on the right side of the pipes as shown in the figure right.

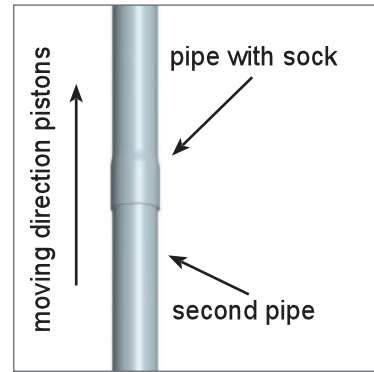

To couple two PVC-pipes together gently heat one end till it softens.



Then put a second pipe in the soft end, and cool it directly with water.

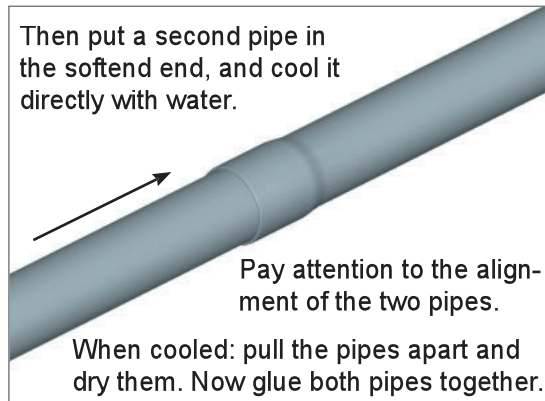

Pay attention to the alignment of the two pipes.

When cooled: pull the pipes apart and dry them. Now glue both pipes together.

If the rising main is assembled including the inlet guide, the exact length has to be determined. Put the pipe (inlet guide first) in the bore hole until it reaches the bottom.

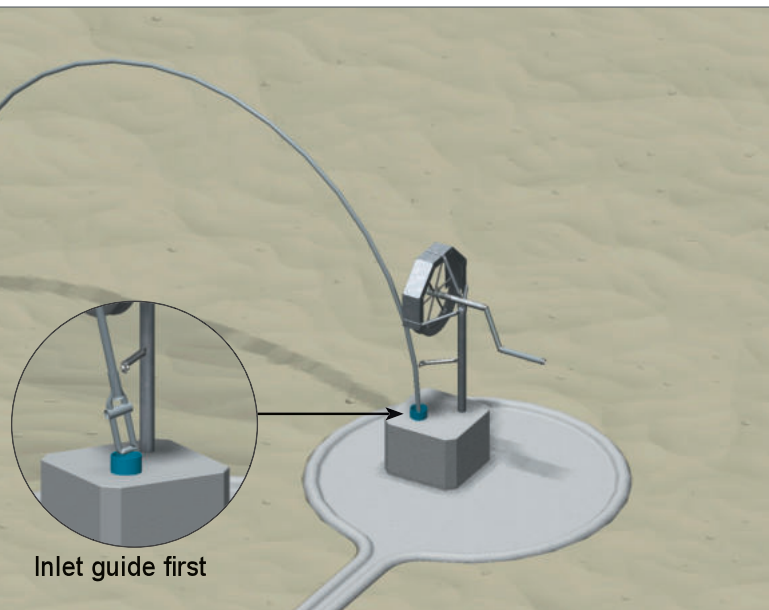

When the inlet guide rests on the bottom, mark out the well casing top on the rising main.

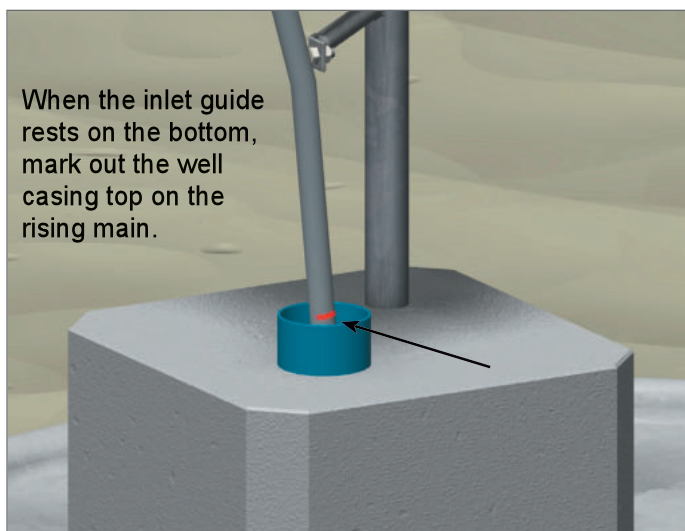

Now remove the rising main out of the bore hole and cut the pipe at the marked place.

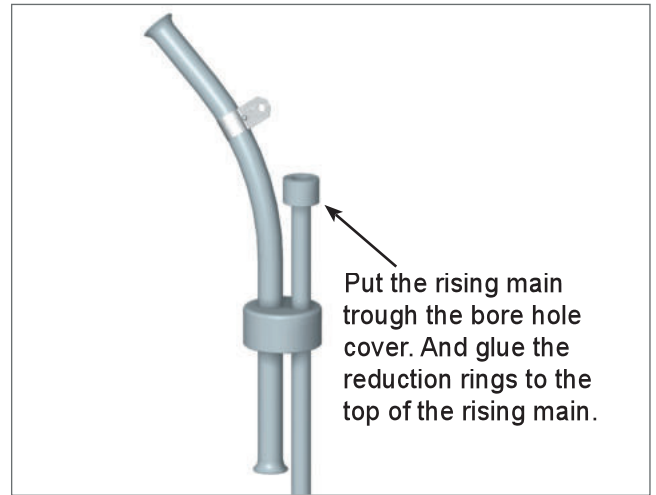
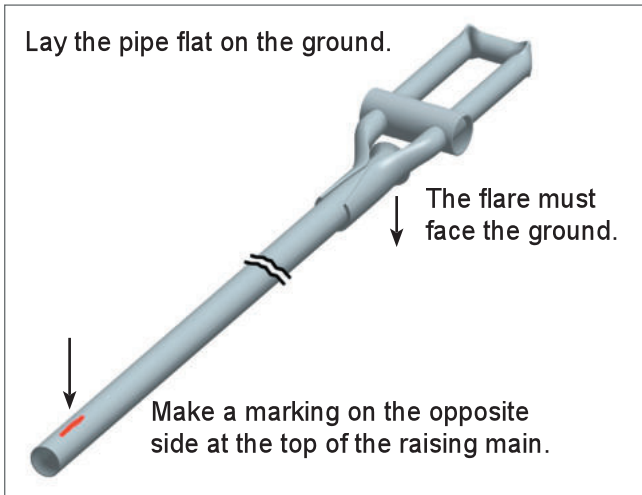

### Rope installation

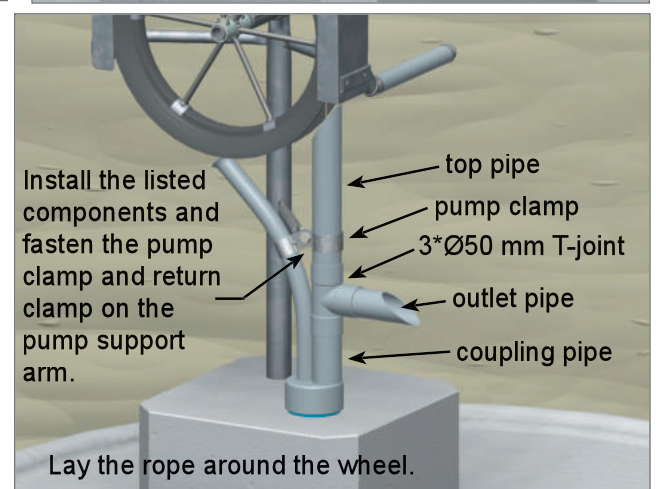
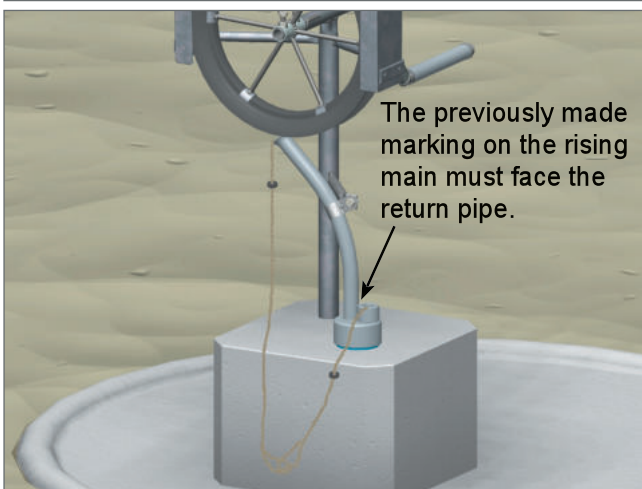
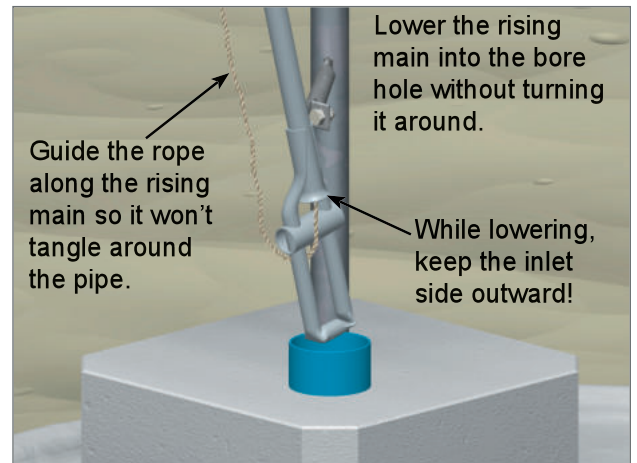
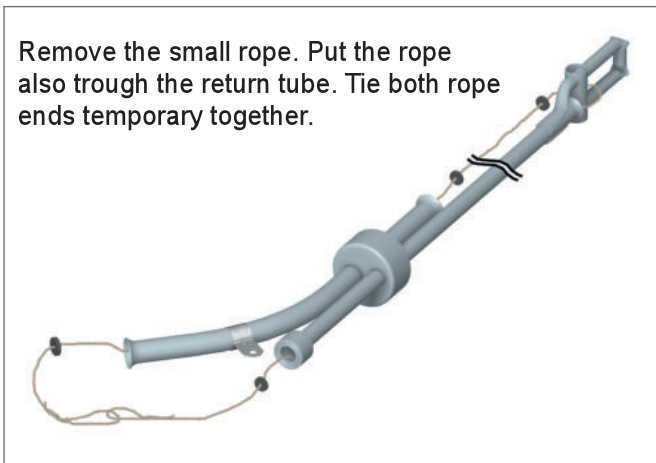
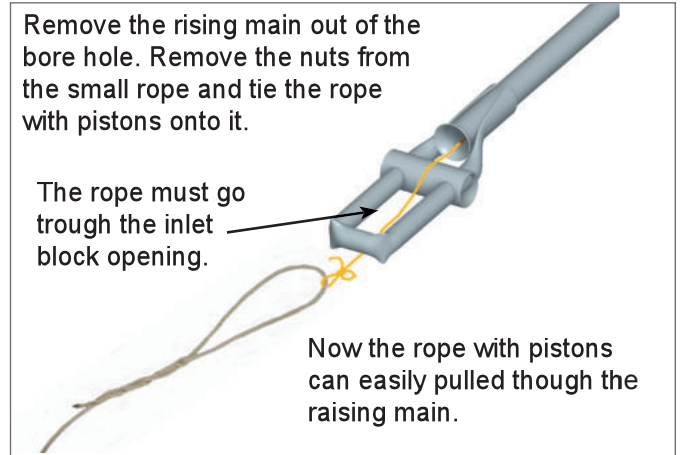
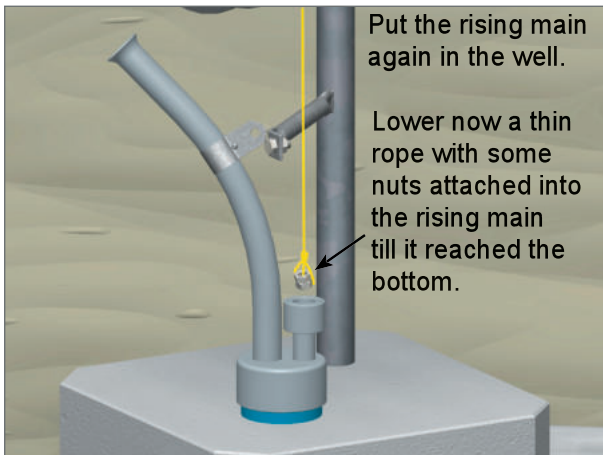

## Rope coupling

Both rope ends are connected together with adjustable loops.

Stitch the rope end 3 or 4 times through the strands.

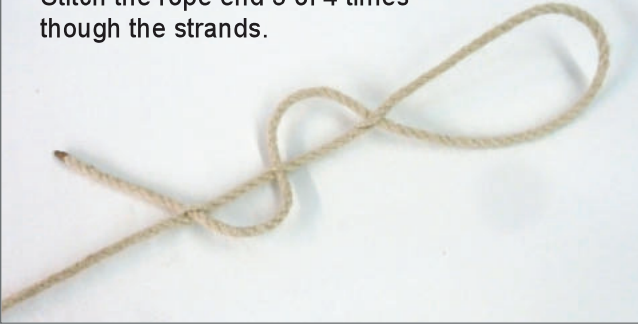

Do this also with the other end with both loops intertwined.

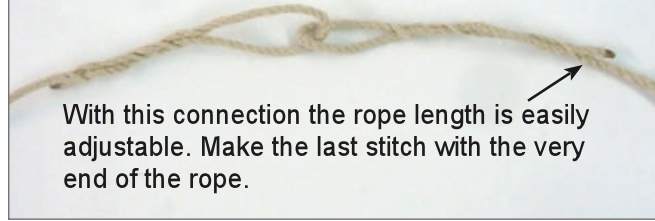

With this connection the rope length is easily adjustable. Make the last stitch with the very end of the rope.



Now adjust the rope length so that there is just a little slack. The photo on the left shows the right amount of slag.

## Maintenance

For a long lifetime of the pump a regular maintenance is essential.

Lubricate the bearing every two weeks with a few drips of oil.

Check the faultless working of the braking mechanism. If necessary take the handle out of the bearing and clean the bearing inside, handle and locking needle.

When signs of wear on the rope appear: Check the strength of the rope and replace it when it's too weak.

## Jigs

However it is possible to make the pump without jigs, the use of jigs are recommended for maintaining the right dimensions and to ease the building of the pump. This chapter describes the necessary jigs.

### Cover bracket bend jig

The cover bend jig is used for checking the bend angle from the horizontal and vertical cover brackets.

This jig can be made from (galvanised) sheet metal.

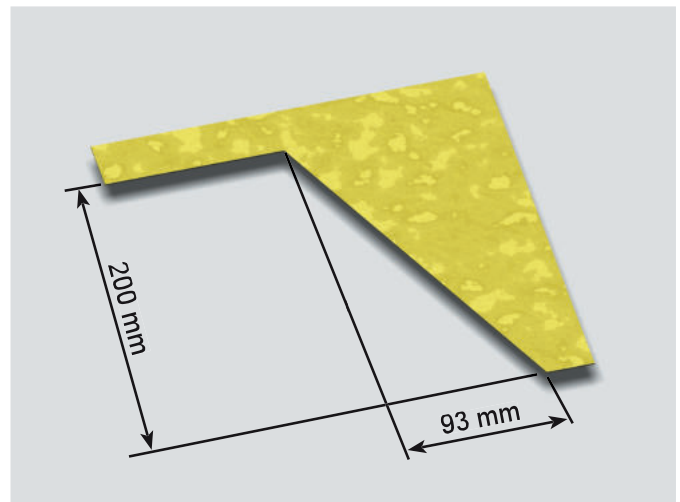

### Pump support bend jig

The pump support bend jig will be used for checking the bend angle from the mounting lip and support arm.

This jig is also made from (galvanised) sheet metal.

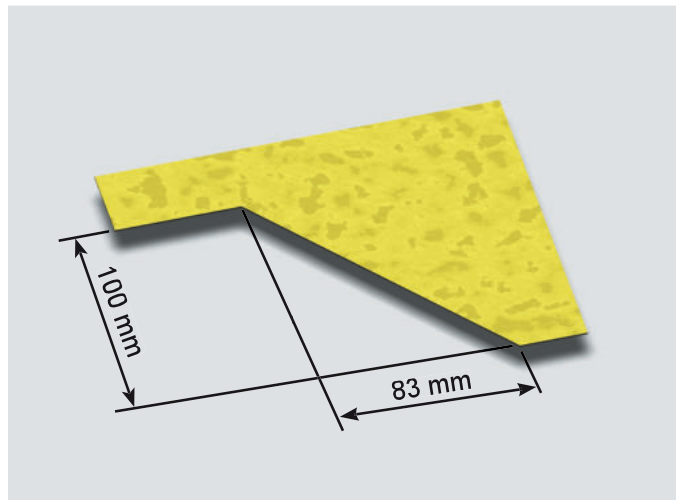

### Handle jig

The handle jig is used for aligning the three handle pipes when they are welded.

This jig is made from 18 mm plywood, ca. 605 mm \* 270 mm.

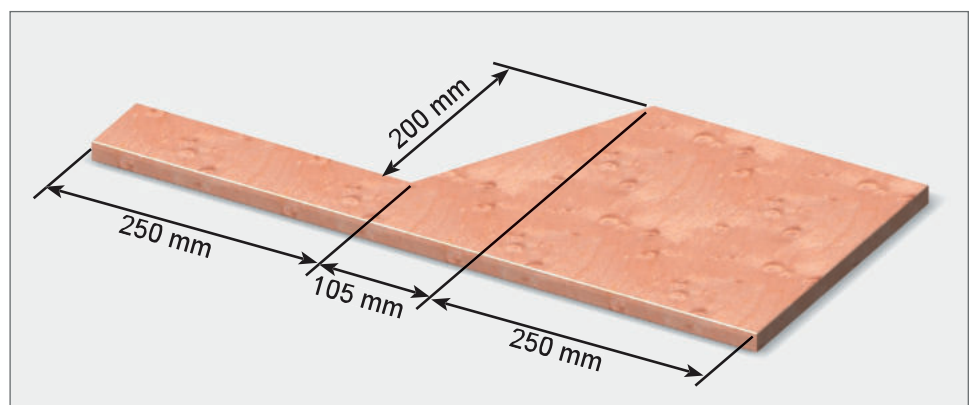

### Frame angle jig

The frame angle jig is used as a welding jig to place the bearing bush and pump support arm perpendicular on the frame pole.

There are 5 pieces angle iron 25\*25\*3 used. For details see the drawing PTP2011/m3.

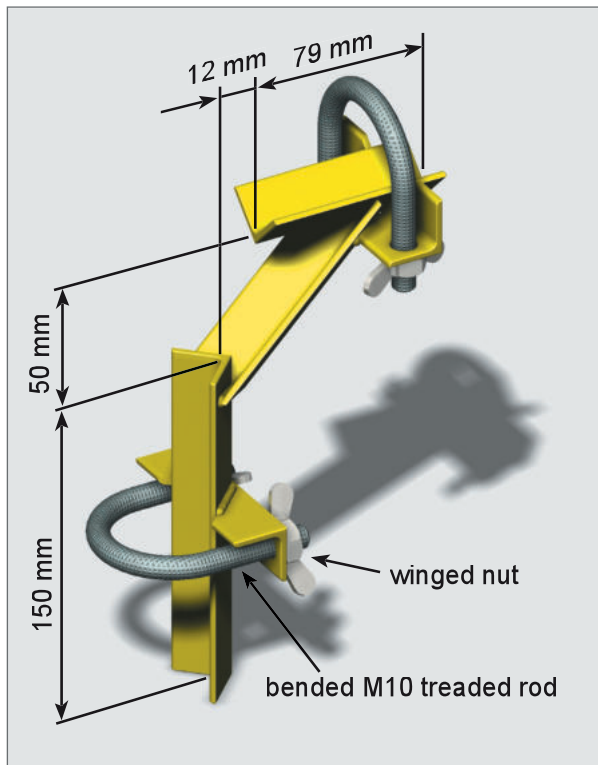

### Cover bracket jig

To fixate the two horizontal and the vertical cover brackets for welding, the cover bracket jig is used.

The frame is made from 6 pieces angle iron 25\*25\*3 and a 3/4" pipe. The jig is drawn in more detail in drawing PTP2011/m4

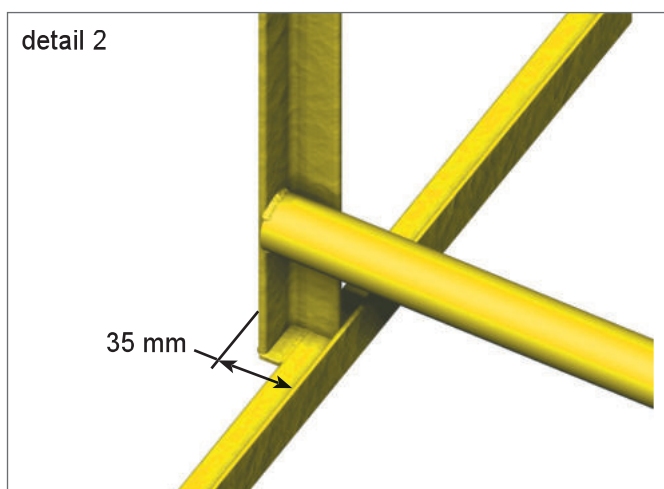
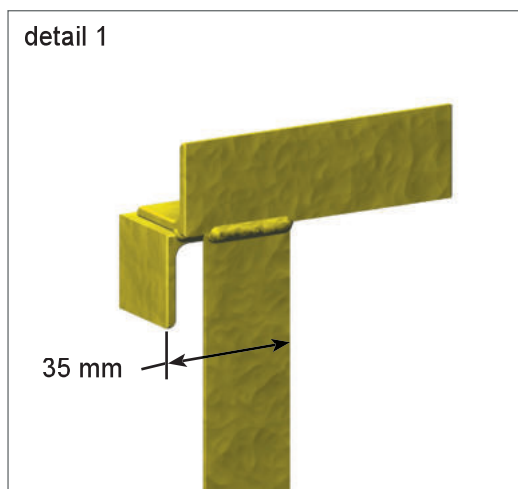
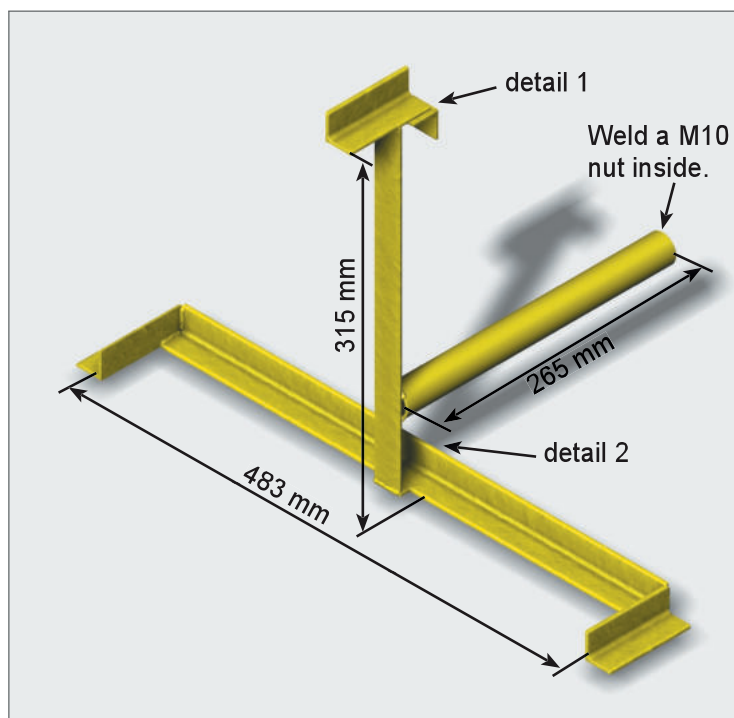



### Wheel welding jig

The wheel welding jig is fixates and aligns the tire parts, the hub and the spokes. With this jig the parts can be welded together with ease.

The base of the jig is a steel base plate ca 150 mm \* 150 mm with a 3/4" pipe welded in the center. The six angle irons 25\*25\*3 are welded on the base plate evenly spreaded with a mutual angle of 60°. To hold the tire parts a small strip is welded on each angle iron. Details of this jig can be found in drawing PTP2011/m1.

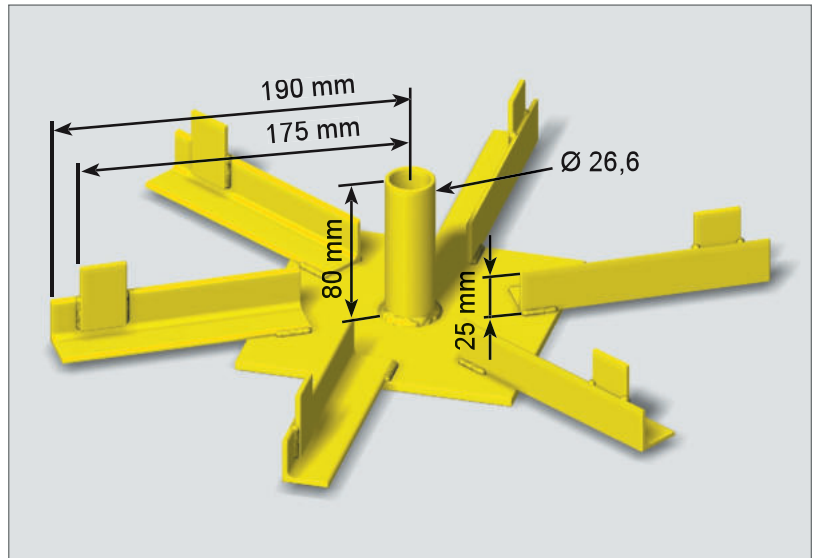

### Return tube jig

The pump return tube has to be bent under a specific angle of 134°. To ease the bending a jig is used.

This jig can be made of a ca. 300 mm \* 600 mm, 18 mm thick plywood plate. Mark out the bord as shown. Clamp or nail two wooden beams on the bord aligned with the drawn lines.

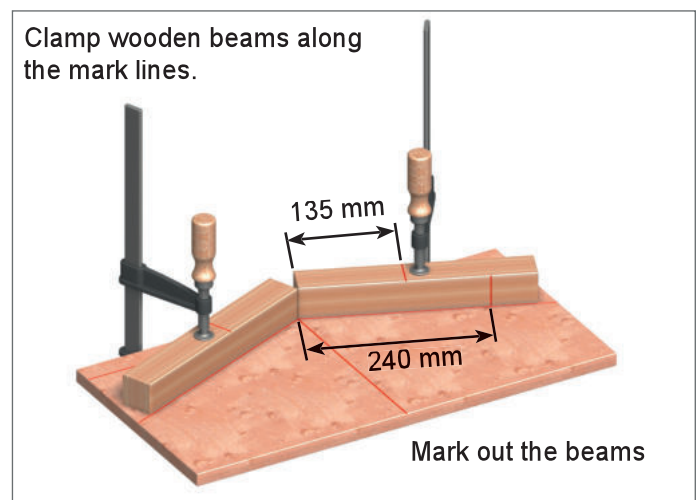
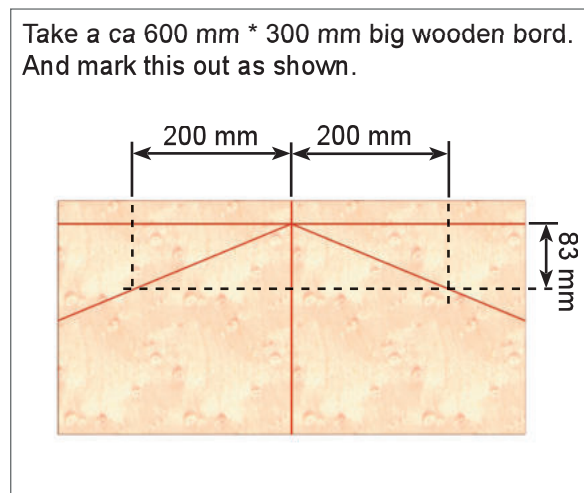

## Errata

To improve the given design the following instructions must be applied.

### **Orientation pump**

*page 21*

Rotate the complete pump 180° with respect to the concrete slab so that the outlet pipe faces the opposite site of the waste water drainage. This is will improve the self cleaning of the concrete floor.

### **Concrete block**

*page 22*

Apply a gentle slope on the top of the concrete block that anchored the pump frame. This prevents that water remains on the block. Also camfer the top edges.

### **Pump clamp**

*page 20*

Make the pump clamp with thicker material, 3 mm instead of 0.7 mm sheet. The pump outlet is then less sensitive for bending out of alignment.