

SCALE ( 1 : 1 )

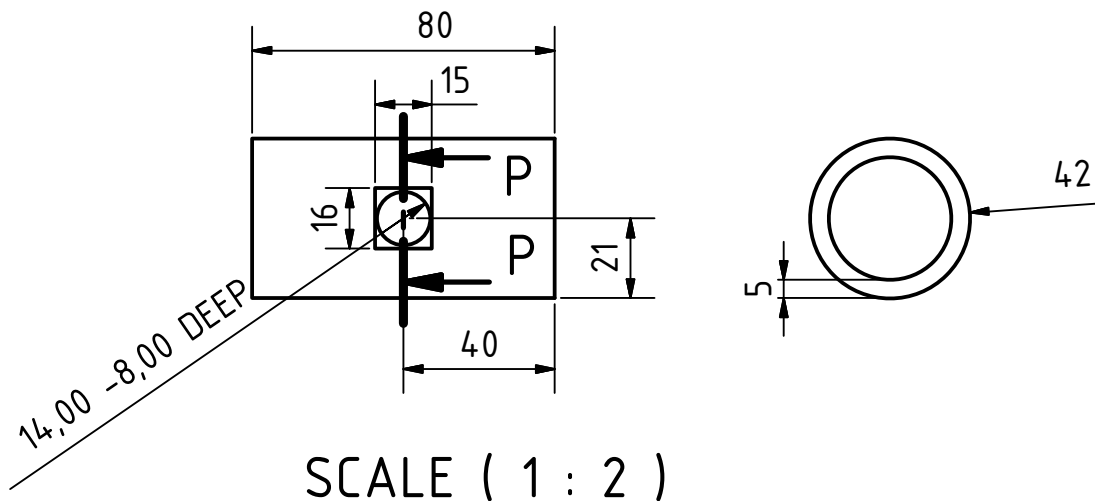
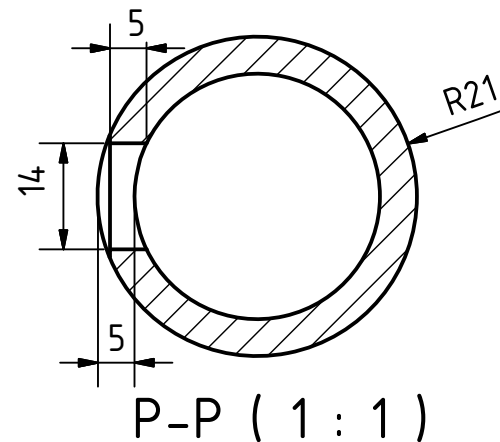
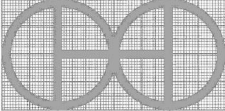

Note: All units in mm.

PROJECT	CREATED BY	APPROVED BY	DATE	VERSION
Ox-drawn Plough	L. Ruda	A. Morillo	09/09/2021	1.0
PART NAME	FILE NAME	POS		
pipe adjustment 80 32 A	pipe adjustment 80 32 A.ipt	2.2		
DEVELOPED BY	REDESIGNED BY	DOC. TYPE	MATERIAL	QUANTITY
		Part	Steel A36	2
Practical Action	OHO e.V.	LICENCE	SCALE	SHEET
		CC-BY-SA 4.0	1:2	11 /26