

Note: All units in mm.

PROJECT	CREATED BY	APPROVED BY	DATE	VERSION
Flat Bottom Boat Scow-Type	J. Zeron	A. Morillo	08/10/2021	1.0
PART NAME	FILE NAME			POS
3D views	Flat Bottom Boat Scow-Type.iam			A1
PUBLISHED BY		DOC. TYPE	MATERIAL	QUANTITY
OHO e.V.		Assembly		1
		LICENCE	SCALE	SHEET
		CC-BY-SA 4.0	1:25	1 / 17

B-B

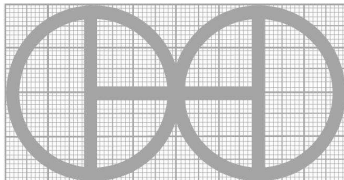
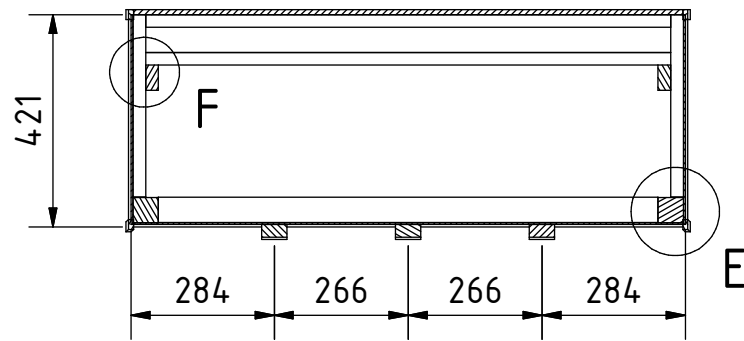

E (1 : 5)

F (1 : 5)

C-C

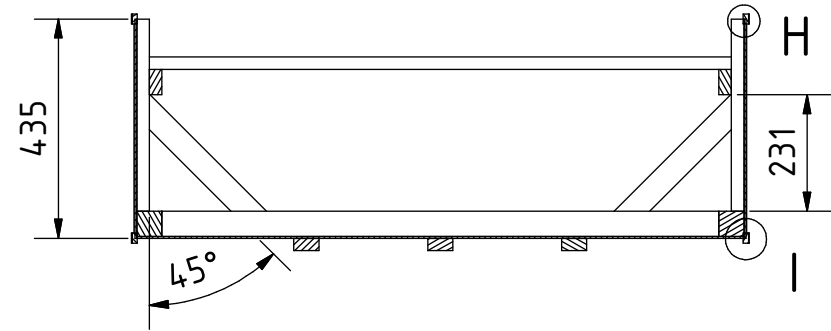

D-D

I (1 : 2)

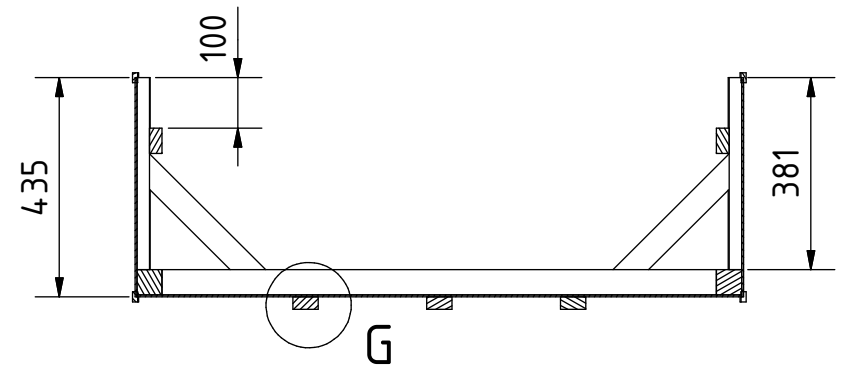
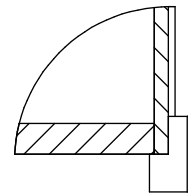

G (1 : 5)

H (1 : 2)

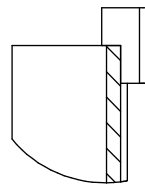
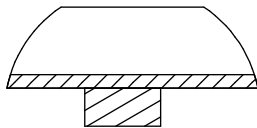

Note: All units in mm.

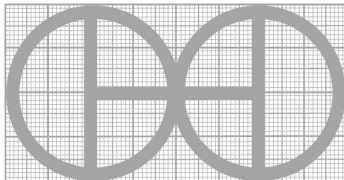
PROJECT	CREATED BY	APPROVED BY	DATE	VERSION
Flat Bottom Boat Scow-Type	J. Zeron	A. Morillo	08/10/2021	1.0
PART NAME	FILE NAME			POS
3D views	Flat Bottom Boat Scow-Type.iam			A1
PUBLISHED BY		DOC. TYPE	MATERIAL	QUANTITY
		Assembly		1
		LICENCE	SCALE	SHEET
OHO e.V.		CC-BY-SA 4.0	1:15	2 / 17

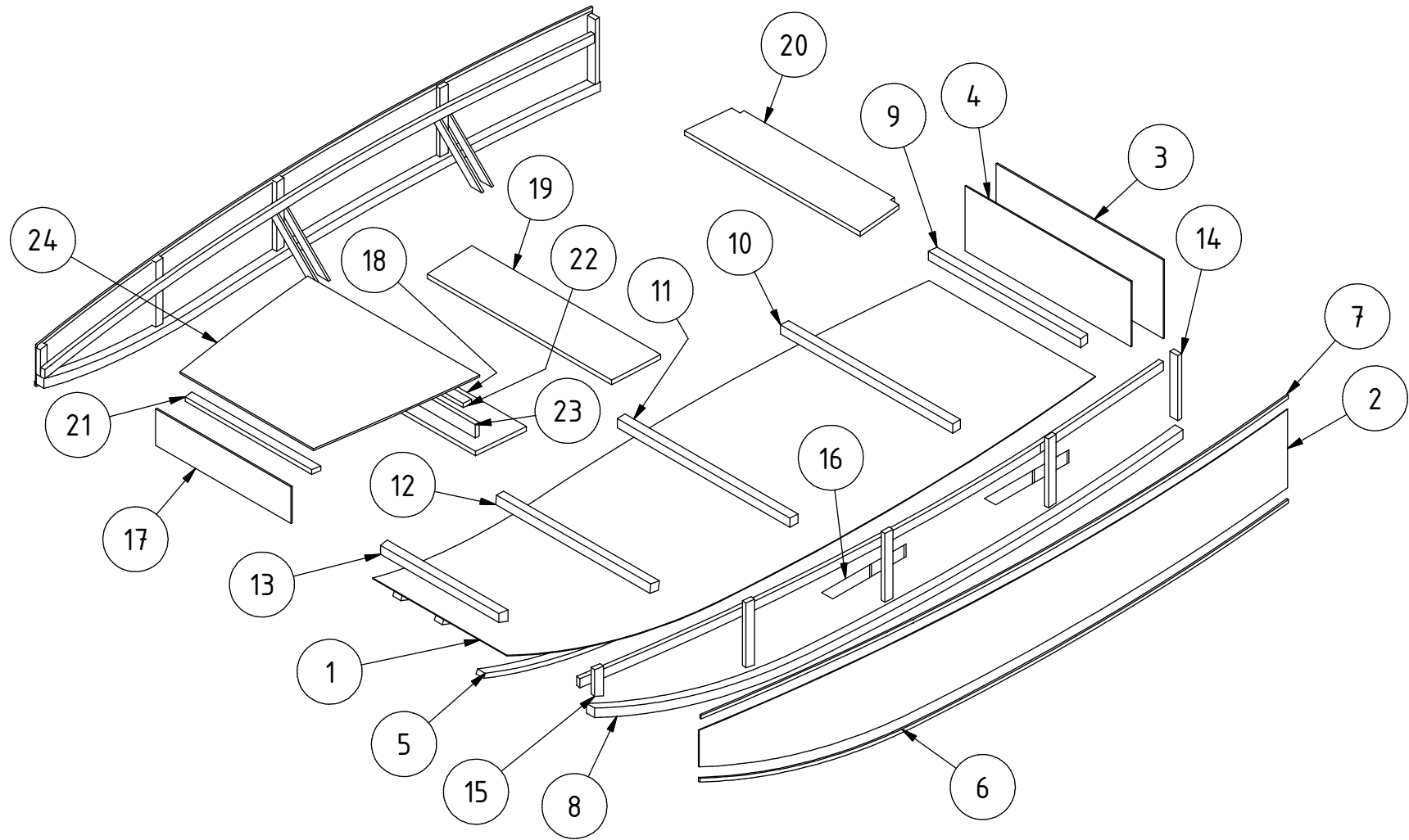

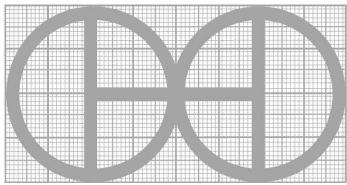
PROJECT	CREATED BY	APPROVED BY	DATE	VERSION
Flat Bottom Boat Scow-Type	J. Zeron	A. Morillo	08/10/2021	1.0
PART NAME	FILE NAME	POS		
Exploded 3D view	Flat Bottom Boat Scow-Type.ipn	A2		
PUBLISHED BY		DOC. TYPE	MATERIAL	QUANTITY
OHO e.V.		Assembly		1
		LICENCE	SCALE	SHEET
		CC-BY-SA 4.0	1:28	3 /17

Parts list

POS	QTY	PART NAME	FILE NAME	PART TYPE	SPECIFICATIONS	SHEET
A1	1	3d views	Flat Bottom Boat Scow-Type.iam	-	-	1
A1	1	3d views	Flat Bottom Boat Scow-Type.iam	-	-	2
A2	1	Exploded 3d view	Flat Bottom Boat Scow-Type.ipn	-	-	3
B1	-	Parts list	Flat Bottom Boat Scow-Type.csv	-	-	4
C1	-	Technical notes	-	-	-	5
1	1	Floor	Floor.ipt	Productuion	Hardwood 12mm	6
2	2	Side wall	Side wall.ipt	Productuion	Hardwood 3.75mm	7
3	1	Rear wall A	-	Productuion	Hardwood 7.50mm	-
4	1	Rear wall B	-	Productuion	Hardwood 7.50mm	-
5	3	Oak runner	Oak runner.ipt	Productuion	Hardwood 25x50mm	8
6	2	Oak chine molding	Oak chine molding.ipt	Productuion	Hardwood 10x30mm	9
7	2	Gunwale	Gunwale.ipt	Productuion	Hardwood 10x30mm	10
8	2	Chine log A	Chine log A.ipt	Productuion	Hardwood 50x50mm	11
9	1	Chine log B	-	Productuion	Hardwood 50x50x973mm	-
10	1	Chine log C	-	Productuion	Hardwood 50x50x1102mm	-
11	1	Chine log D	-	Productuion	Hardwood 50x50x1105mm	-
12	1	Chine log E	-	Productuion	Hardwood 50x50x986mm	-
13	1	Chine log F	-	Productuion	Hardwood 50x50x756mm	-
14	8	Vertical reinforcement A	-	Productuion	Hardwood 25x50x381mm	-
15	2	Vertical reinforcement B	Vertical reinforcement B.ipt	Productuion	Hardwood 25x50x381mm	12
16	8	Gusset	Gusset.ipt	Productuion	Hardwood 13x50mm	13
17	1	Front wall	-	Productuion	Hardwood 7.50mm	-
18	1	Seat A	Seat A.ipt	Productuion	Hardwood 25mm	14
19	1	Seat B	Seat B.ipt	Productuion	Hardwood 25mm	15
20	1	Seat C	Seat C.ipt	Productuion	Hardwood 25mm	16
21	1	Horizontal bracket A	-	Productuion	Hardwood 25x50x808mm	-
22	1	Horizontal bracket B	-	Productuion	Hardwood 25x50x1046mm	-
23	1	Seat back	-	Productuion	Hardwood 25x75x1097mm	-
24	1	Top cap	Top cap.ipt	Productuion	Hardwood 10mm	17
25	200	Join	-	Buy	Galvanized nails 1.8x35mm	-

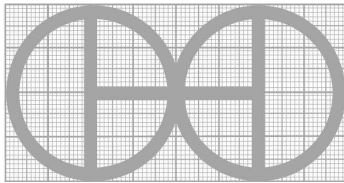
PROJECT		CREATED BY		APPROVED BY		DATE		VERSION	
Flat Bottom Boat Scow-Type		J. Zeron		A. Morillo		08/10/2021		1.0	
PART NAME			FILE NAME					POS	
Parts list			Flat Bottom Boat Scow-Type.csv					B1	
PUBLISHED BY					DOC. TYPE		MATERIAL		QUANTITY
OHO e.V.					Parts list		LICENCE		SCALE
					CC-BY-SA 4.0				4 / 17

TECHNICAL NOTES

NOTES	CONTENT
GENERAL NOTES	
Wood treatment	<ul style="list-style-type: none"> - The wood must be treated with pesticides and kiln-dried to ensure adequate humidity. - Wood sealer should be applied for later use. - Apply wood preservative on all surfaces. - Painting the outside of the bottom with bitumastic paint. - All joints should be treated with an asphalt-based or bitumastic compound during the construction. It may be necessary to caulk eventual bad leaks with caulking compound afterwards. - All wood pieces must be glued together with white glue before nailing.

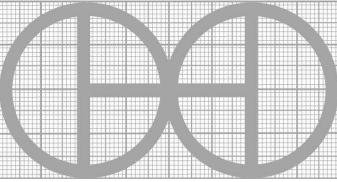
PROJECT Flat Bottom Boat Scow-Type	CREATED BY J. Zeron	APPROVED BY A. Morillo	DATE 08/10/2021	VERSION 1.0
PART NAME Technical notes	FILE NAME			POS C1
PUBLISHED BY OHO e.V.		DOC. TYPE Technical notes	MATERIAL	QUANTITY
LICENCE CC-BY-SA 4.0		SCALE	SHEET 5 /17	

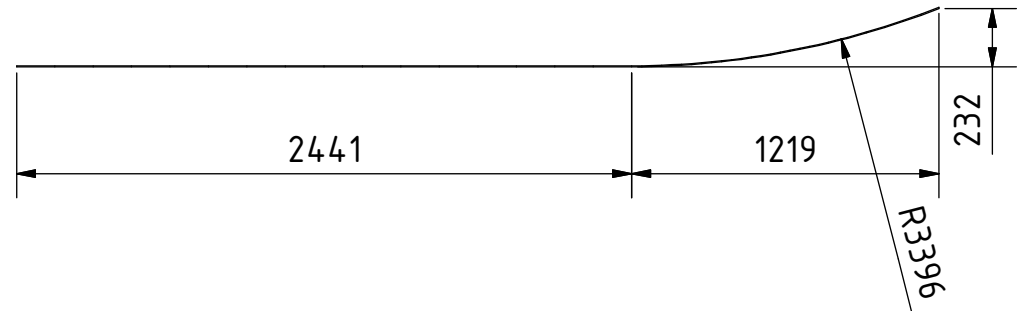
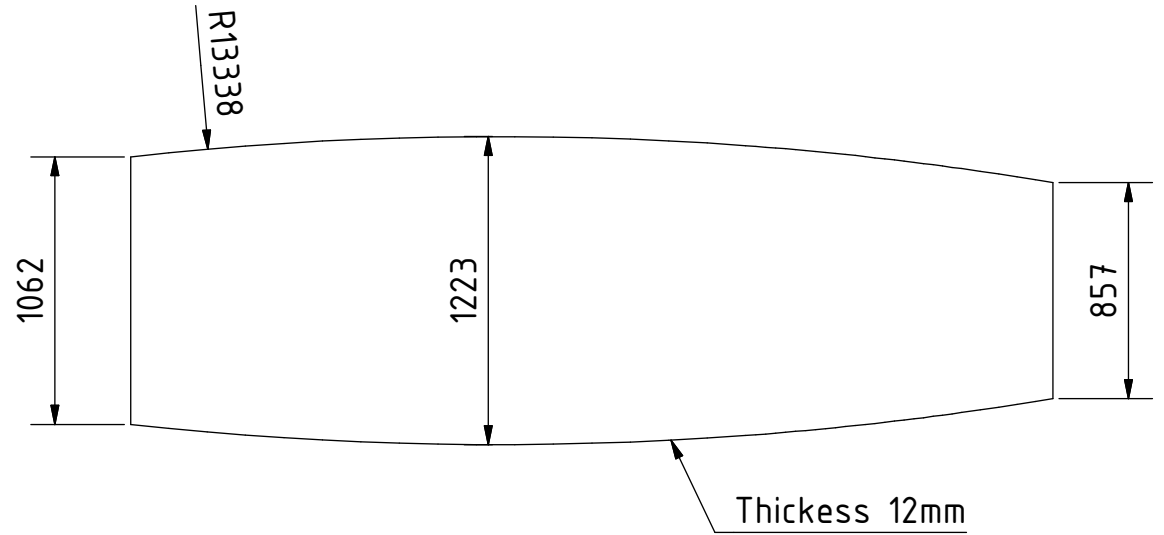
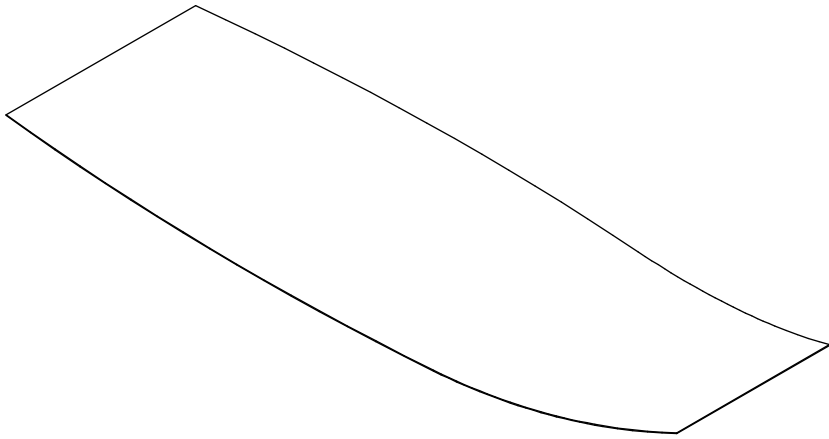

Note: All units in mm.

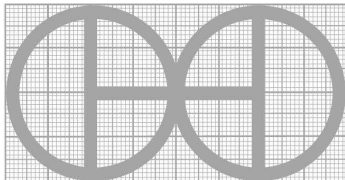
PROJECT	CREATED BY	APPROVED BY	DATE	VERSION
Flat Bottom Boat Scow-Type	J. Zeron	A. Morillo	08/10/2021	1.0
PART NAME	FILE NAME			POS
Floor	Floor.ipt			1
PUBLISHED BY		DOC. TYPE	MATERIAL	QUANTITY
OHO e.V.		Part	Hardwood	1
		LICENCE	SCALE	SHEET
		CC-BY-SA 4.0	1:30	6 /17

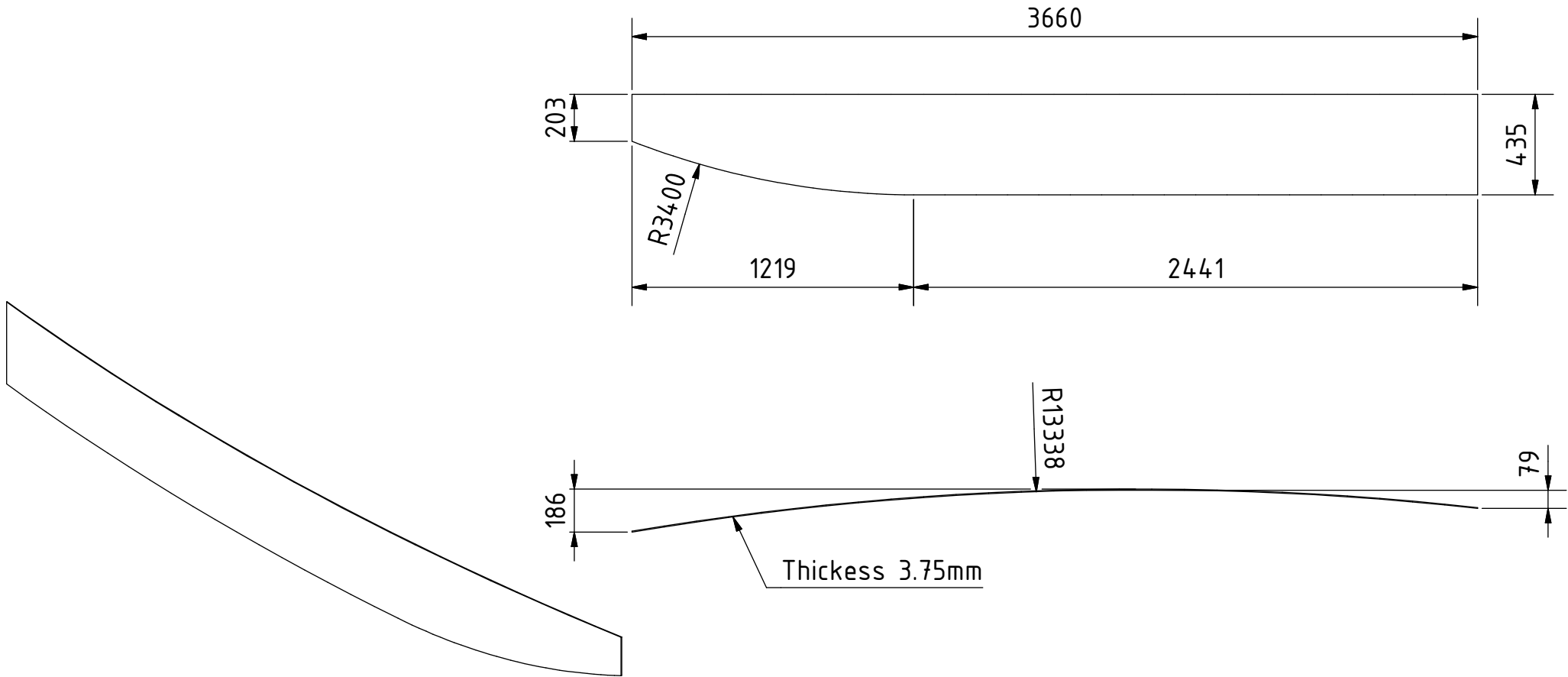

Note: All units in mm.

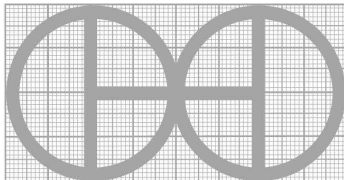
PROJECT	CREATED BY	APPROVED BY	DATE	VERSION
Flat Bottom Boat Scow-Type	J. Zeron	A. Morillo	08/10/2021	1.0
PART NAME	FILE NAME			POS
Side wall	Side wall.ipt			2
PUBLISHED BY		DOC. TYPE	MATERIAL	QUANTITY
OHO e.V.		Part	Hardwood	2
		LICENCE	SCALE	SHEET
		CC-BY-SA 4.0	1:25	7 / 17

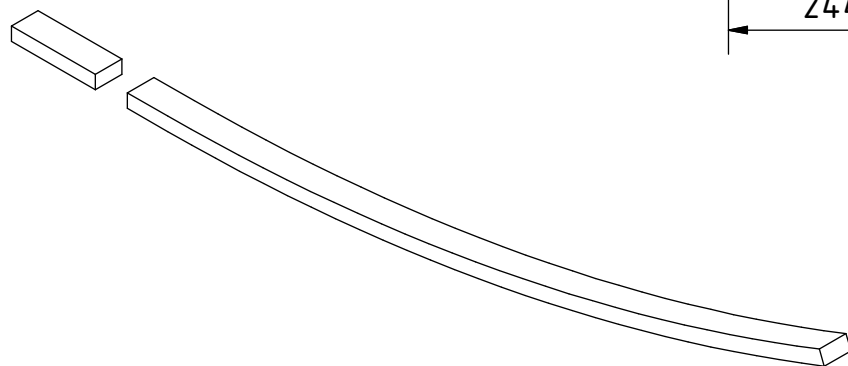
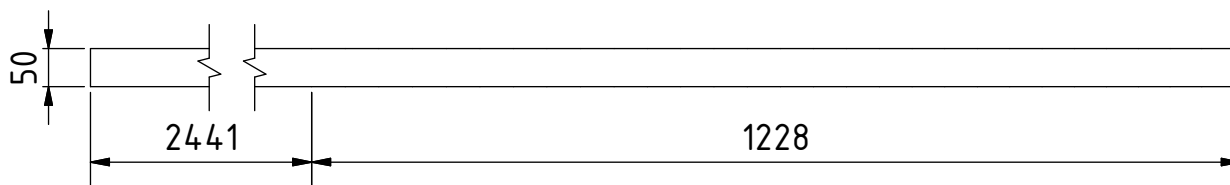
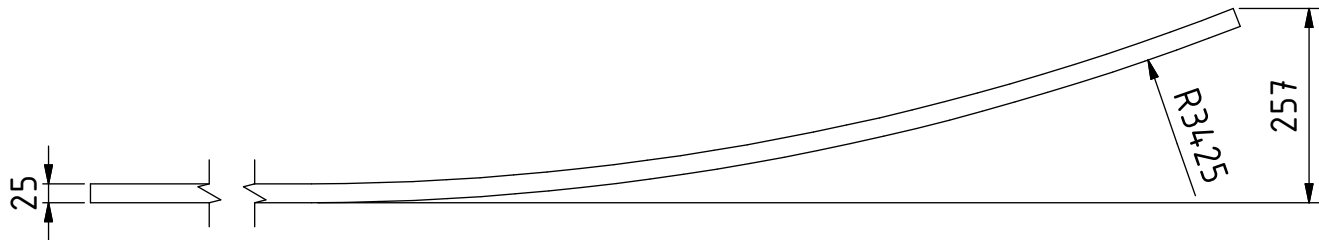

Note: All units in mm.

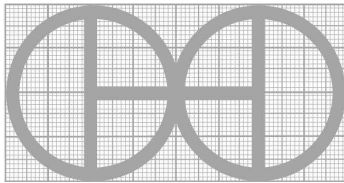
PROJECT	CREATED BY	APPROVED BY	DATE	VERSION
Flat Bottom Boat Scow-Type	J. Zeron	A. Morillo	08/10/2021	1.0
PART NAME	FILE NAME			POS
Oak runner	Oak runner.ipt			5
PUBLISHED BY		DOC. TYPE	MATERIAL	QUANTITY
		Part	Hardwood	3
		LICENCE	SCALE	SHEET
OHO e.V.		CC-BY-SA 4.0	1:10	8 /17

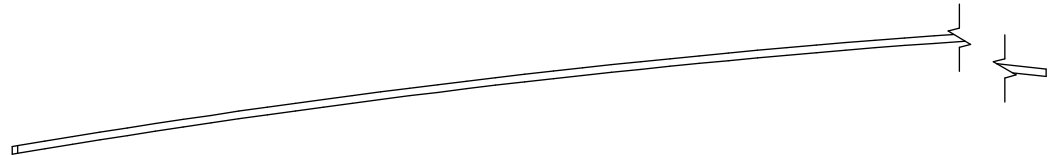
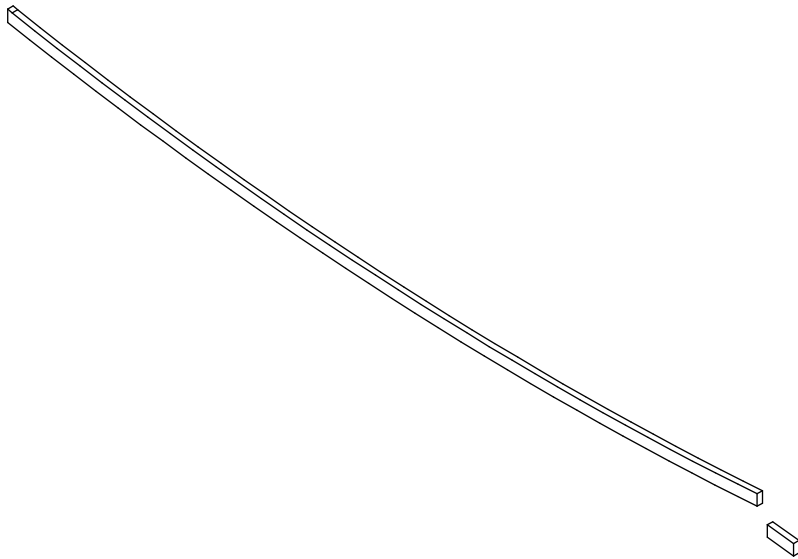
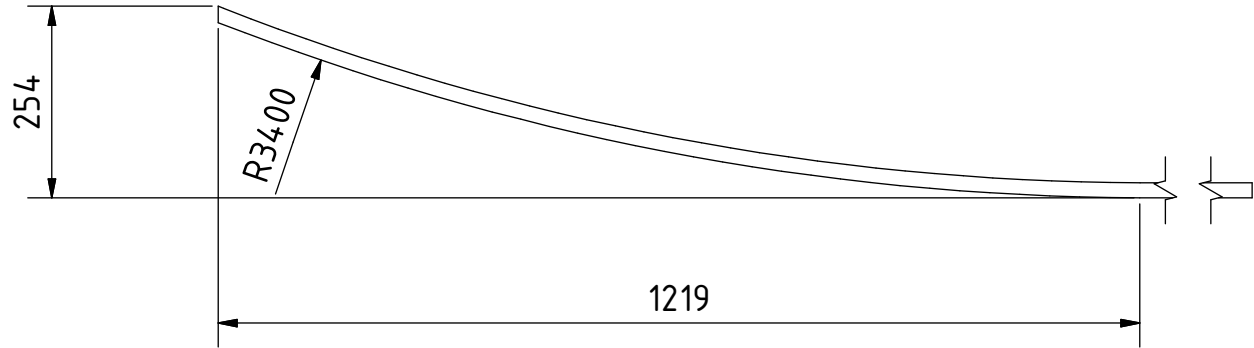
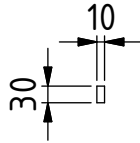

Note: All units in mm.

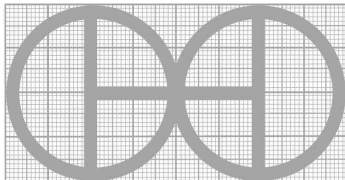
PROJECT	CREATED BY	APPROVED BY	DATE	VERSION
Flat Bottom Boat Scow-Type	J. Zeron	A. Morillo	08/10/2021	1.0
PART NAME	FILE NAME			POS
Oak chine molding	Oak chine molding.ipt			6
PUBLISHED BY		DOC. TYPE	MATERIAL	QUANTITY
		Part	Hardwood	2
		LICENCE	SCALE	SHEET
OHO e.V.		CC-BY-SA 4.0	1:10	9 /17

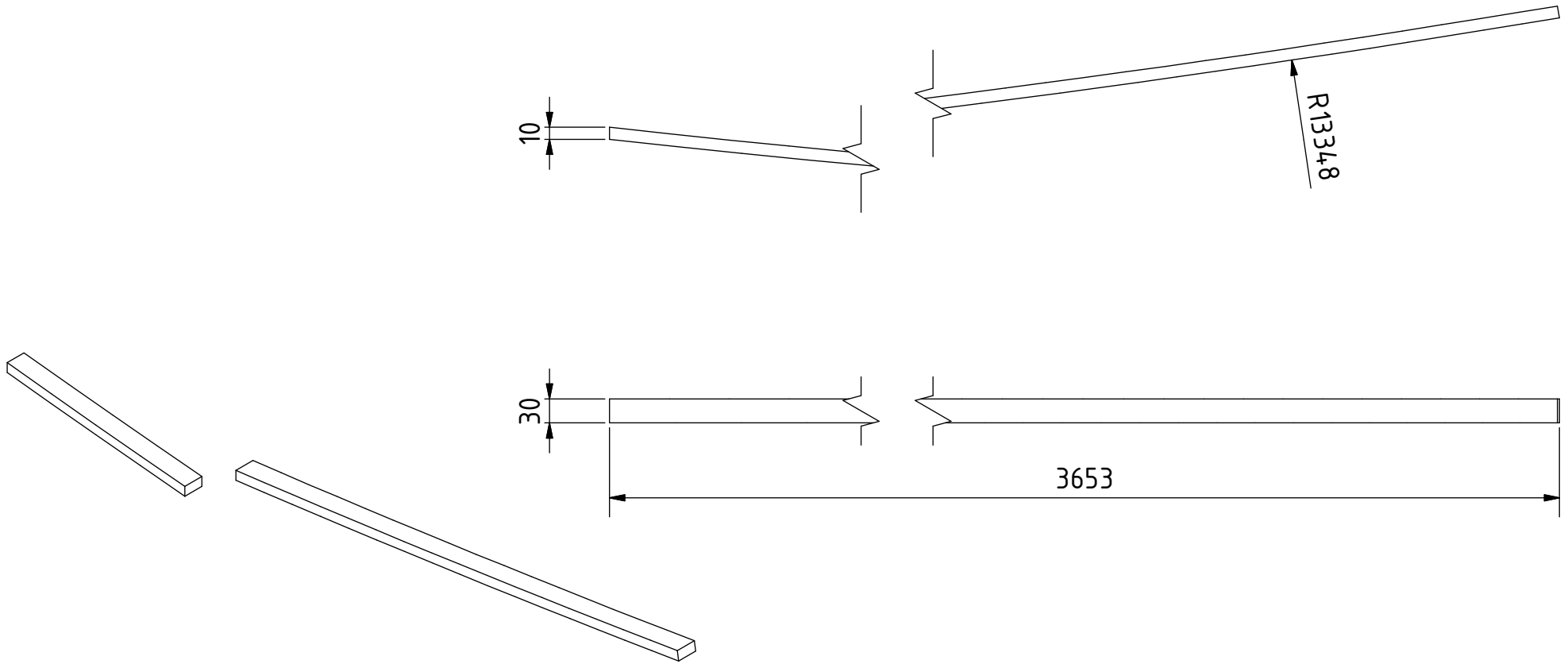

Note: All units in mm.

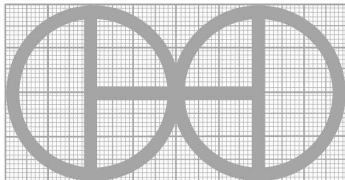
PROJECT	CREATED BY	APPROVED BY	DATE	VERSION
Flat Bottom Boat Scow-Type	J. Zeron	A. Morillo	08/10/2021	1.0
PART NAME	FILE NAME			POS
Gunwale	Gunwale.ipt			7
PUBLISHED BY		DOC. TYPE	MATERIAL	QUANTITY
OHO e.V.		Part	Hardwood	2
		LICENCE	SCALE	SHEET
		CC-BY-SA 4.0	1:5	10 /17

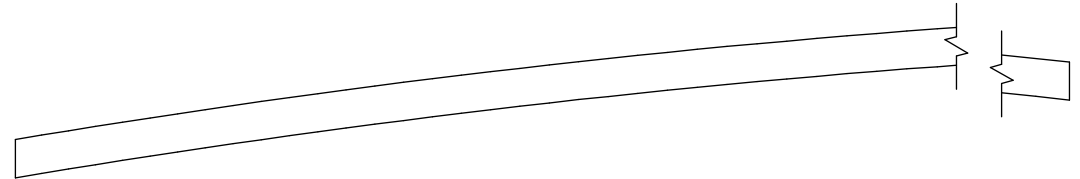
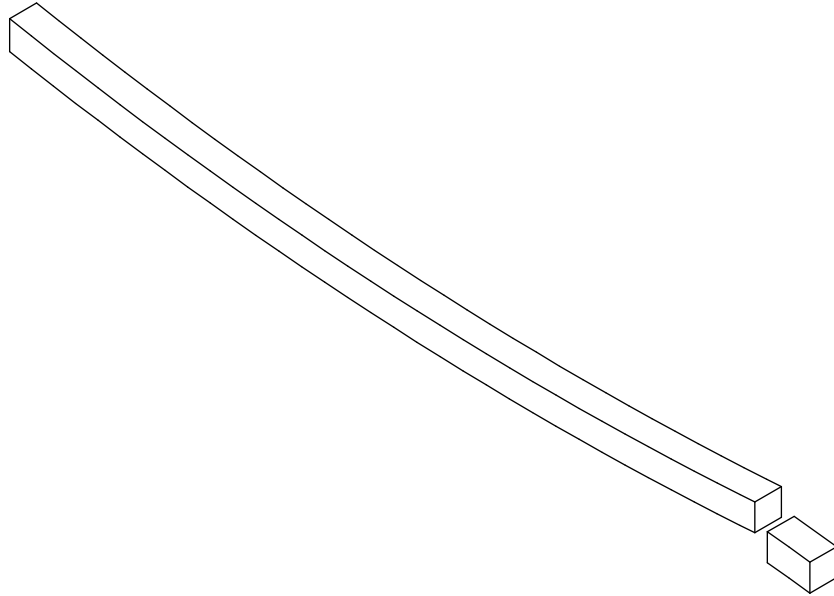
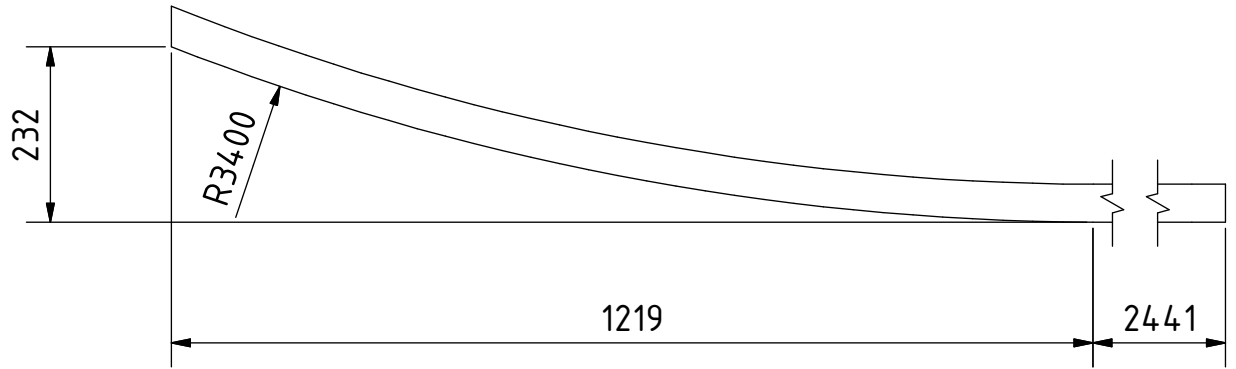
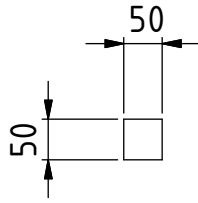

Note: All units in mm.

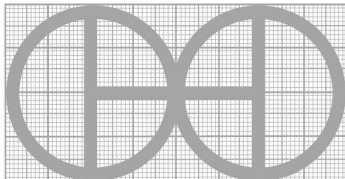
PROJECT	CREATED BY	APPROVED BY	DATE	VERSION
Flat Bottom Boat Scow-Type	J. Zeron	A. Morillo	08/10/2021	1.0
PART NAME	FILE NAME			POS
Chine log A	Chine log A.ipt			8
PUBLISHED BY		DOC. TYPE	MATERIAL	QUANTITY
		Part	Hardwood	2
		LICENCE	SCALE	SHEET
OHO e.V.		CC-BY-SA 4.0	1:10	11 /17

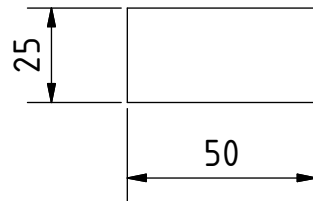
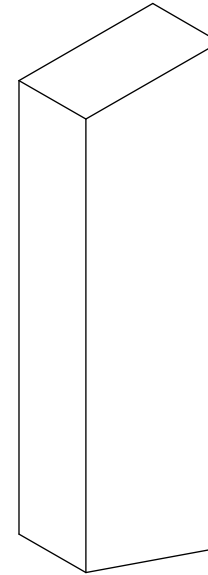
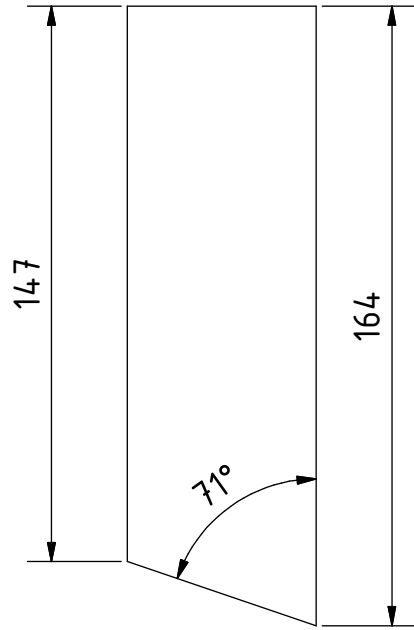

Note: All units in mm.

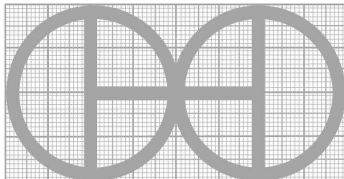
PROJECT	CREATED BY	APPROVED BY	DATE	VERSION
Flat Bottom Boat Scow-Type	J. Zeron	A. Morillo	08/10/2021	1.0
PART NAME	FILE NAME			POS
Vertical reinforcement B	Vertical reinforcement B.ipt			15
PUBLISHED BY		DOC. TYPE	MATERIAL	QUANTITY
OHO e.V.		Part	Hardwood	2
		LICENCE	SCALE	SHEET
		CC-BY-SA 4.0	1:2	12 /17

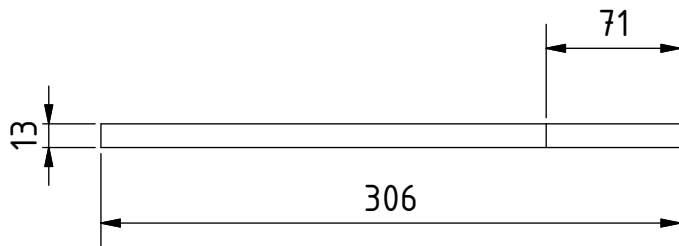
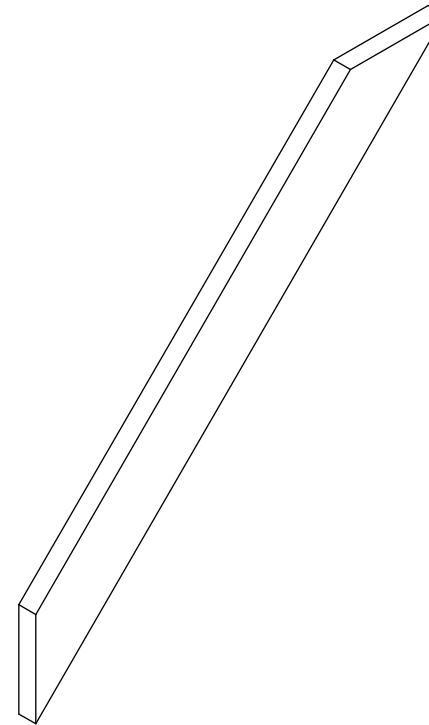
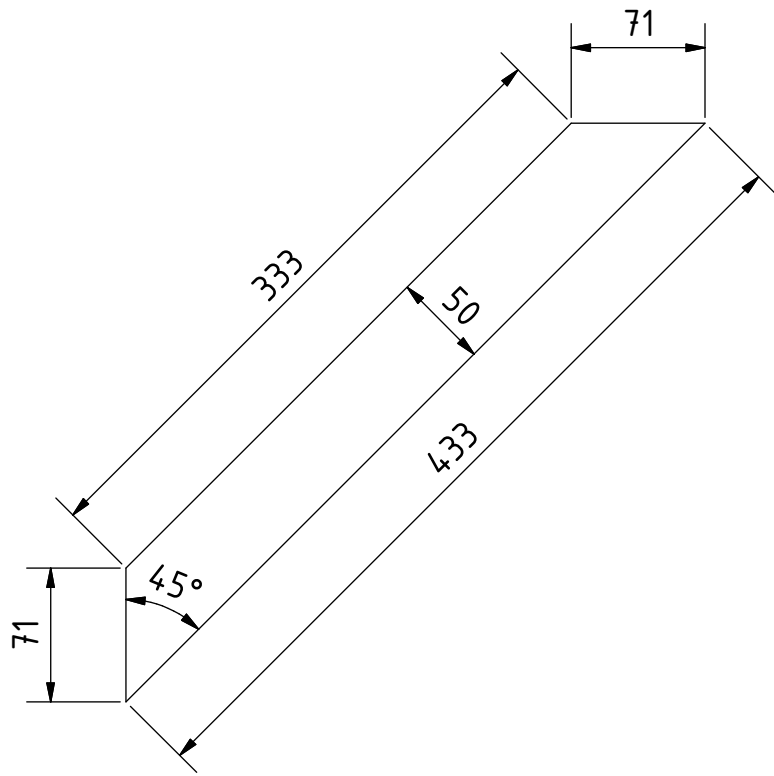

Note: All units in mm.

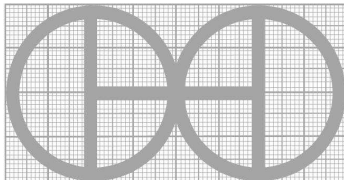
PROJECT	CREATED BY	APPROVED BY	DATE	VERSION
Flat Bottom Boat Scow-Type	J. Zeron	A. Morillo	08/10/2021	1.0
PART NAME	FILE NAME			POS
Gusset	Gusset.ipt			16
PUBLISHED BY		DOC. TYPE	MATERIAL	QUANTITY
OHO e.V.		Part	Hardwood	8
		LICENCE	SCALE	SHEET
		CC-BY-SA 4.0	1:4	13 /17

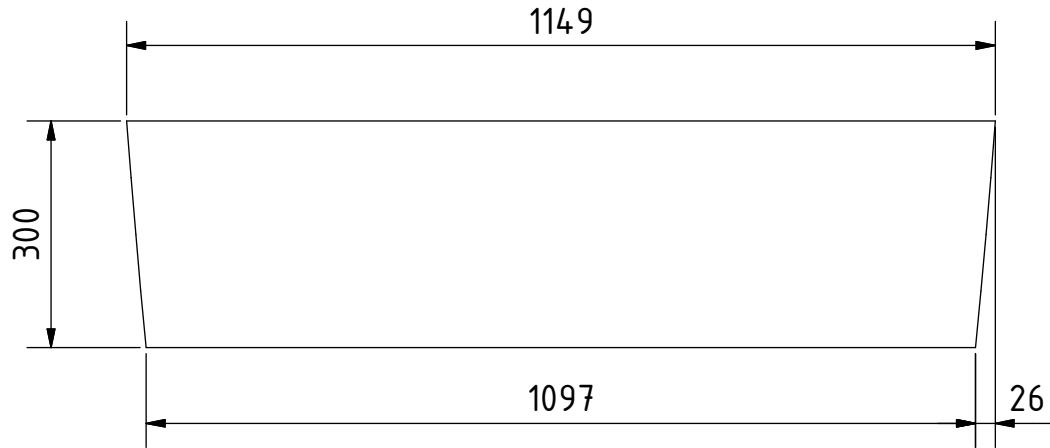
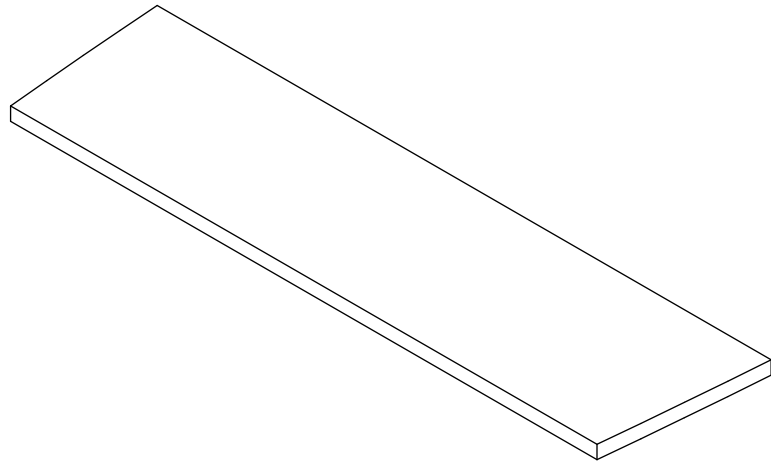

Note: All units in mm.

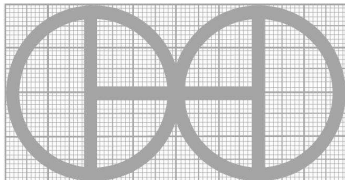
PROJECT	CREATED BY	APPROVED BY	DATE	VERSION
Flat Bottom Boat Scow-Type	J. Zeron	A. Morillo	08/10/2021	1.0
PART NAME	FILE NAME			POS
Seat A	Seat A.ipt			18
PUBLISHED BY		DOC. TYPE	MATERIAL	QUANTITY
OHO e.V.		Part	Hardwood	1
		LICENCE	SCALE	SHEET
		CC-BY-SA 4.0	1:10	14 /17

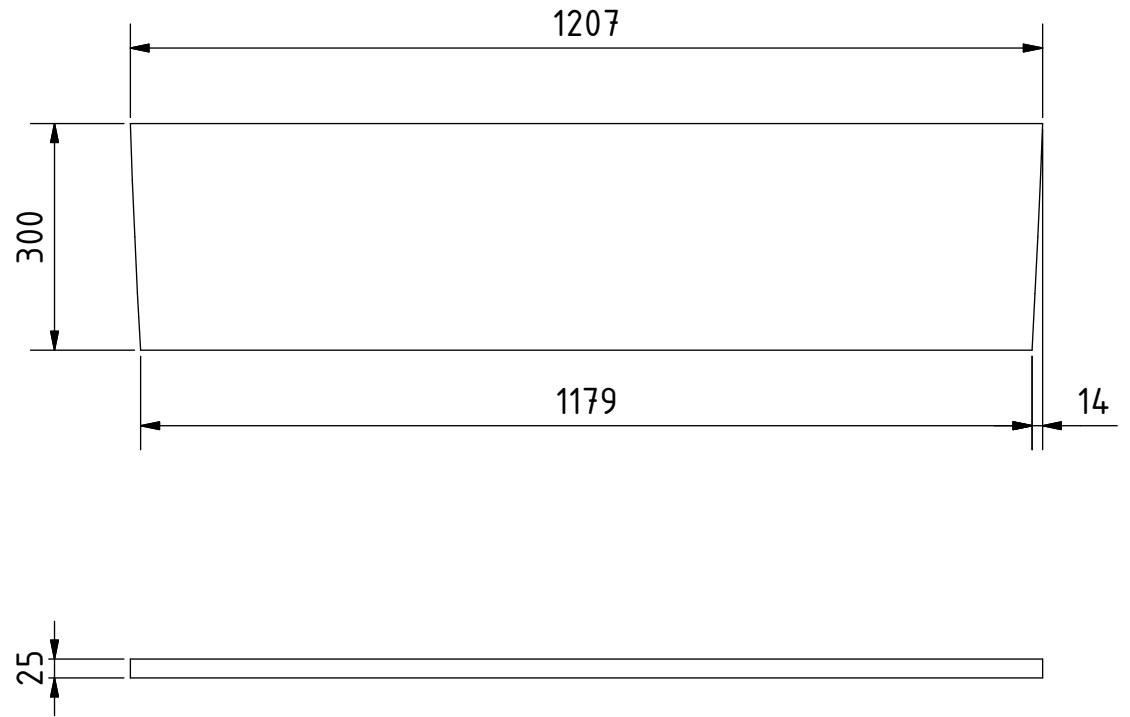
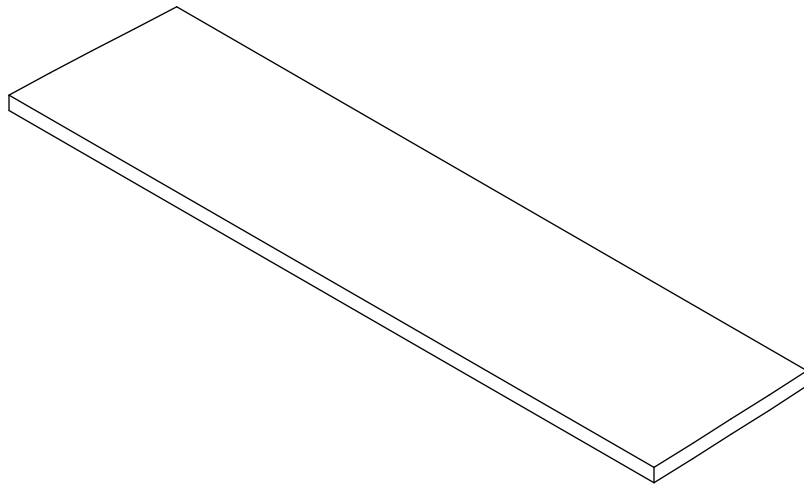

Note: All units in mm.

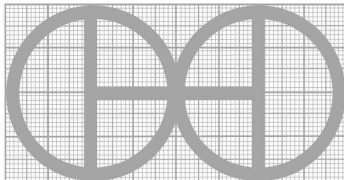
PROJECT	CREATED BY	APPROVED BY	DATE	VERSION
Flat Bottom Boat Scow-Type	J. Zeron	A. Morillo	08/10/2021	1.0
PART NAME	FILE NAME			POS
Seat B	Seat B.ipt			19
PUBLISHED BY		DOC. TYPE	MATERIAL	QUANTITY
OHO e.V.		Part	Hardwood	1
		LICENCE	SCALE	SHEET
		CC-BY-SA 4.0	1:10	15 /17

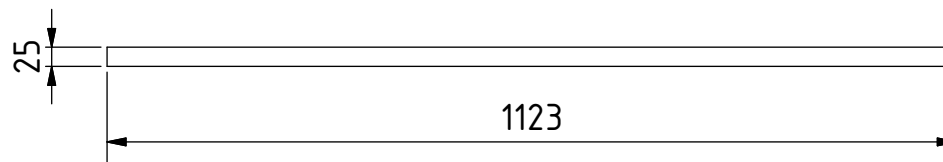
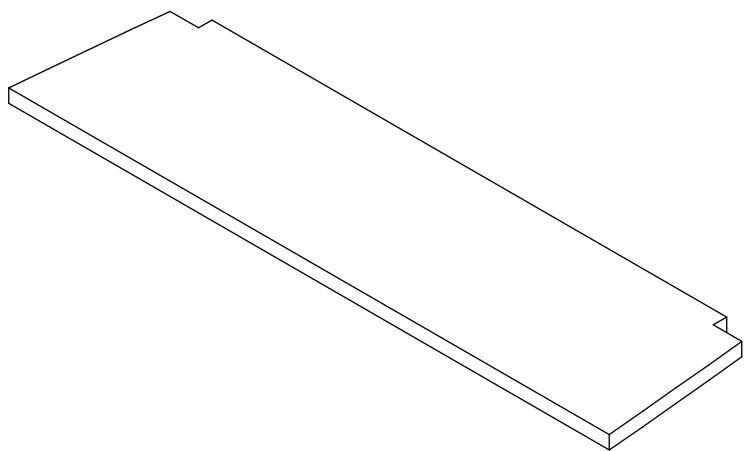
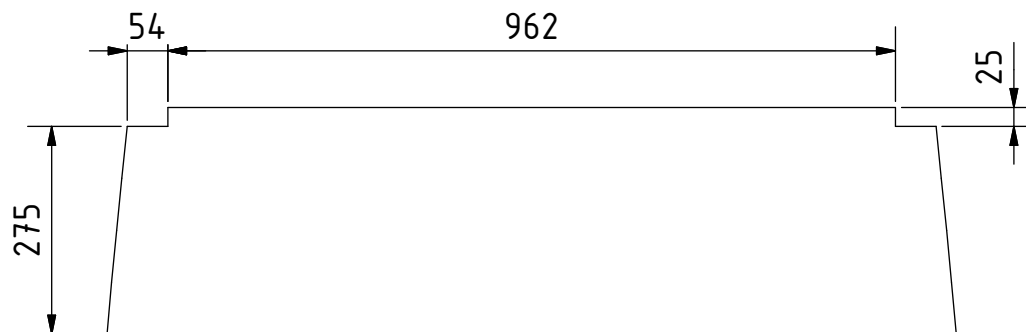

Note: All units in mm.

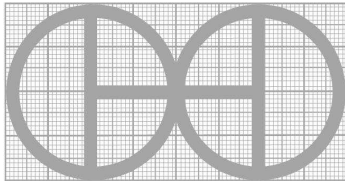
PROJECT	CREATED BY	APPROVED BY	DATE	VERSION
Flat Bottom Boat Scow-Type	J. Zeron	A. Morillo	08/10/2021	1.0
PART NAME	FILE NAME			POS
Seat C	Seat C.ipt			20
PUBLISHED BY		DOC. TYPE	MATERIAL	QUANTITY
OHO e.V.		Part	Hardwood	1
		LICENCE	SCALE	SHEET
		CC-BY-SA 4.0	1:10	16 /17

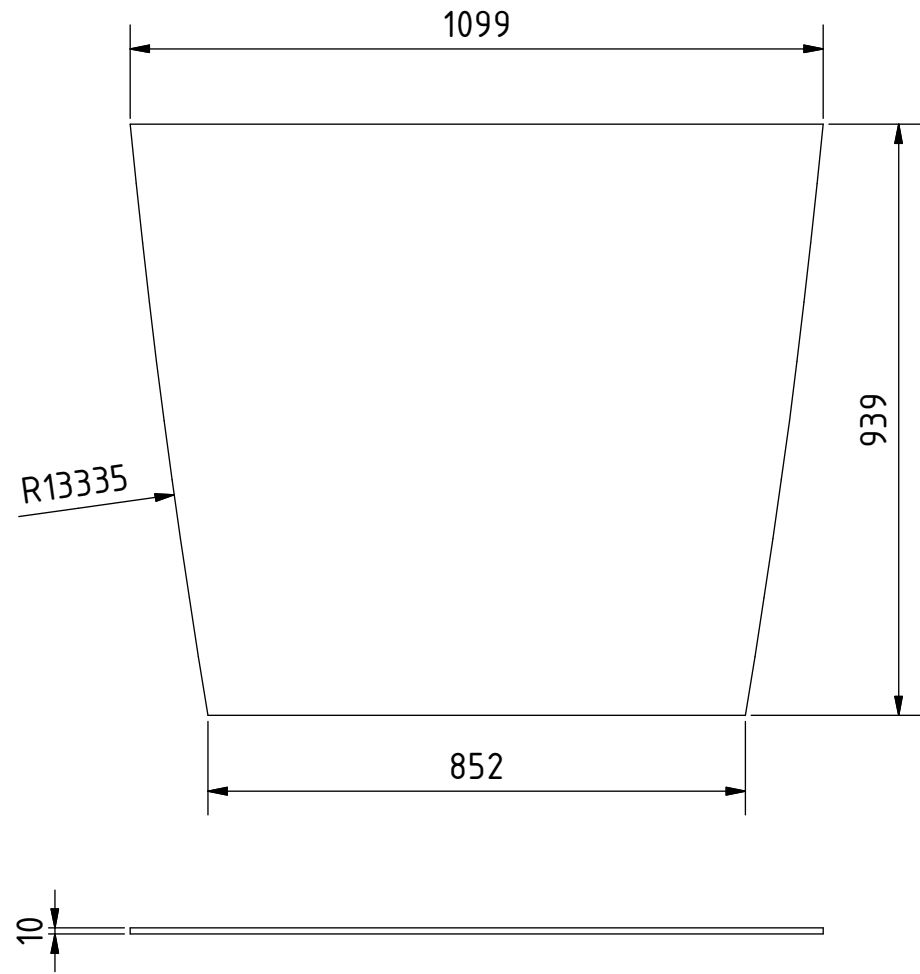
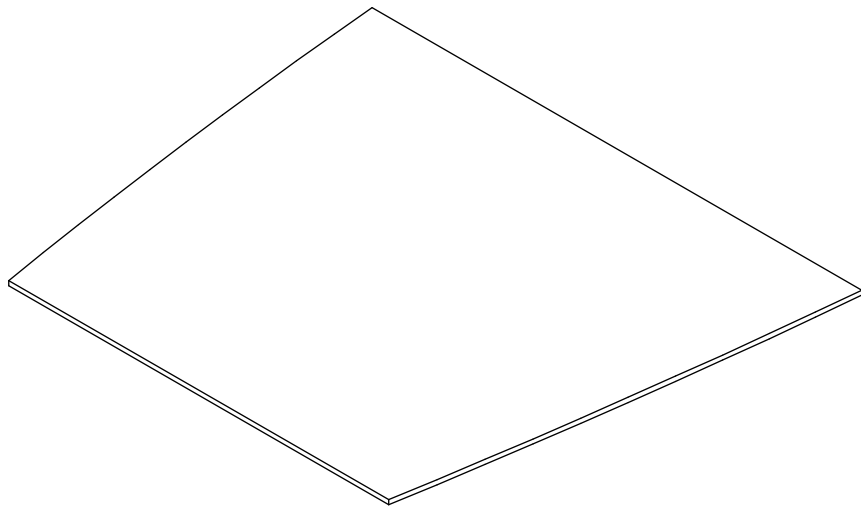

Note: All units in mm.

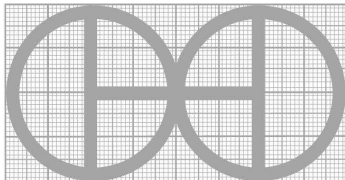
PROJECT	CREATED BY	APPROVED BY	DATE	VERSION
Flat Bottom Boat Scow-Type	J. Zeron	A. Morillo	08/10/2021	1.0
PART NAME	FILE NAME			POS
Top cap	Top cap.ipt			24
PUBLISHED BY		DOC. TYPE	MATERIAL	QUANTITY
OHO e.V.		Part	Hardwood	1
		LICENCE	SCALE	SHEET
		CC-BY-SA 4.0	1:12	17 /17