

DR: Drehgelenk.  
Hinweis: Alle einheiten in mm.

PROJEKT	ERSTELLT VON	GENEHMIGT VON	DATE	VERSION
Schmiedefaltenbalg	J. Zeron	A. Morillo	30/07/2021	1.0
TEIL-NAME	DATEI-NAME			TEIL-CODE
3d-Ansichten	ung_bb_blacksmiths-bellows.iam			A1
ENTWICKELT VON	UMGESTALTET VON	DOK. TYP	WERKSTOFF	MENGE
University of Technology LAE Papua New Guinea	OHO e.V.	Assembly		-
		LIZENZ	SCALE	SEITE
		CC-BY-SA 4.0	1:13	1 / 22

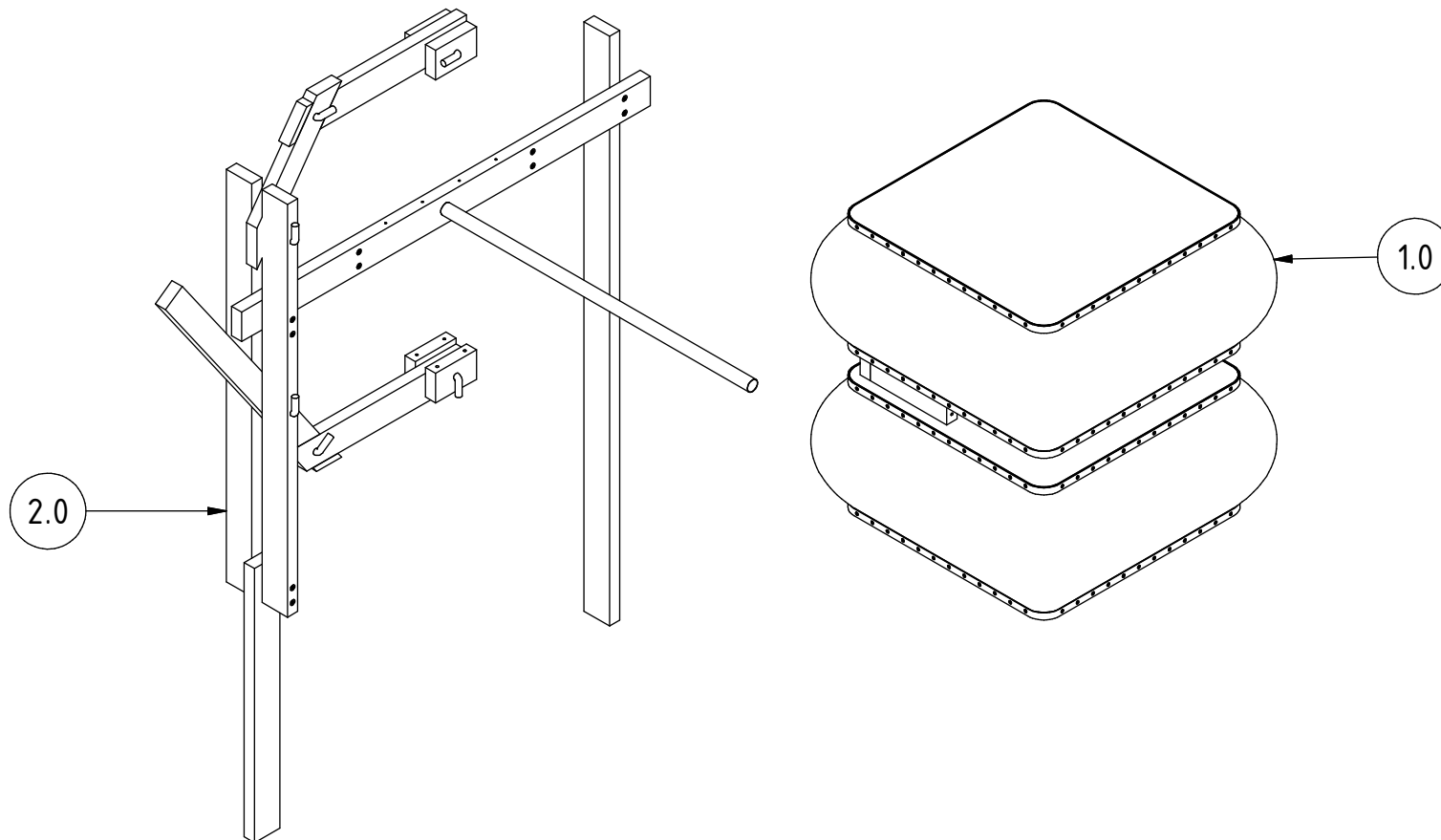
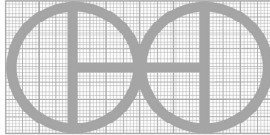

PROJEKT	ERSTELLT VON	GENEHMIGT VON	DATE	VERSION
Schmiedefaltenbalg	J. Zeron	A. Morillo	30/07/2021	1.0
TEIL-NAME	DATEI-NAME			TEIL-CODE
3d-Explosionszeichnungen	ung_bb_blacksmiths-bellows.ipn			A2
ENTWICKELT VON	UMGESTALTET VON	DOK. TYP	WERKSTOFF	MENGE
University of Technology LAE Papua New Guinea	 OHO e.V.	Assembly		
		LIZENZ	SCALE	SEITE
		CC-BY-SA 4.0	1:10	2 /22

Parts list

POS	QTY	TEIL NAME	DATEI-NAME	TEIL-TYP	SPEZIFIKATIONEN	SEITE
A1	-	3d-Ansichten	ung_bb_blacksmiths-bellows.iam	-	-	1
A2	-	3d-Explosionszeichnungen	ung_bb_blacksmiths-bellows.ipn	-	-	2
B1	-	Teileliste	ung_bb_blacksmiths-bellows.csv	-	-	3
1.0	-	Balg	Bellows.ipn	-	-	4
1.1	2	Elastischer schlauchgummi	-	Production	Elastischer gummi	-
1.2	1	Quadratisches brett A	Square board A.ipt	Production	Sperrholz 12mm	5
1.3	2	Quadratisches brett B	Square board B.ipt	Production	Sperrholz 12mm	6
1.4	1	Quadratisches brett C	Square board C.ipt	Production	Sperrholz 12mm	7
1.5	4	Blech	Sheet metal.ipt	Production	Stahlblech C45 G25	8
1.6	192	Schraube A	-	Standard	BS 4183 schraube M3x10mm	-
1.7	2	Buchsbaumholz A	Box timber A.ipt	Production	Hartholz 50x20mm	9
1.8	1	Buchsbaumholz B	Box timber B.ipt	Production	Hartholz 50x20mm	10
1.9	4	Schraube B	-	Standard	BS 4183 schraube M5x30mm	-
1.10	3	Klappe	-	Buy	Schwergummi 260x80mm	-
1.11	3	Blech	-	Production	Stahlblech C45 G25, 10x80mm	-
1.12	28	Schraube C	-	Standard	BS 4183 schraube M3x20mm	-
1.13	8	Schraube D	-	Standard	BS 4183 schraube M5x30mm	-
2.0	-	Rahmen	Frame.ipn	-	-	11
2.1	1	Fub A	Foot A.ipt	Production	Hartholz 50x20mm	12
2.2	1	Fub B	Foot B.ipt	Production	Hartholz 50x20mm	13
2.3	2	Fub C	Foot C.ipt	Production	Hartholz 50x20mm	14
2.4	1	Buchsbaumholz C	Box timber C.ipt	Production	Hartholz 50x20mm	15
2.5	4	Kleinholz	Small timber.ipt	Production	Hartholz 50x20mm	16
2.6	2	Arm A	Arm A.ipt	Production	Hartholz 50x20mm	17
2.7	1	Arm B	Arm B.ipt	Production	Hartholz 40x20mm	18
2.8	1	Arm C	Arm C.ipt	Production	Hartholz 40x20mm	19
2.9	8	Schraube E	-	Standard	BS 4183 schraube M6x60m	-
2.10	8	Schraube F	-	Standard	BS 4183 schraube M5x30mm	-
2.11	2	Stift A	Pin A.ipt	Production	Stahl A36 10mm	20
2.12	2	Stift B	Pin B.ipt	Production	Stahl A36 10mm	21
2.13	2	Stift C	Pin C.ipt	Production	Stahl A36 10mm	22

PROJEKT		ERSTELLT VON		GENEHMIGT VON		DATE		VERSION	
Schmiedefaltenbalg		J. Zeron		A. Morillo		30/07/2021		1.0	
TEIL-NAME		DATEI-NAME						TEIL-CODE	
Teileliste		ung_bb_blacksmiths-bellows.csv						B1	
ENTWICKELT VON		UMGESTALTET VON		DOK. TYP		WERKSTOFF		MENGE	
University of Technology LAE Papua New Guinea		 OHO e.V.		Parts list				-	
				LIZENZ		SCALE		SEITE	
				CC-BY-SA 4.0				3 /22	

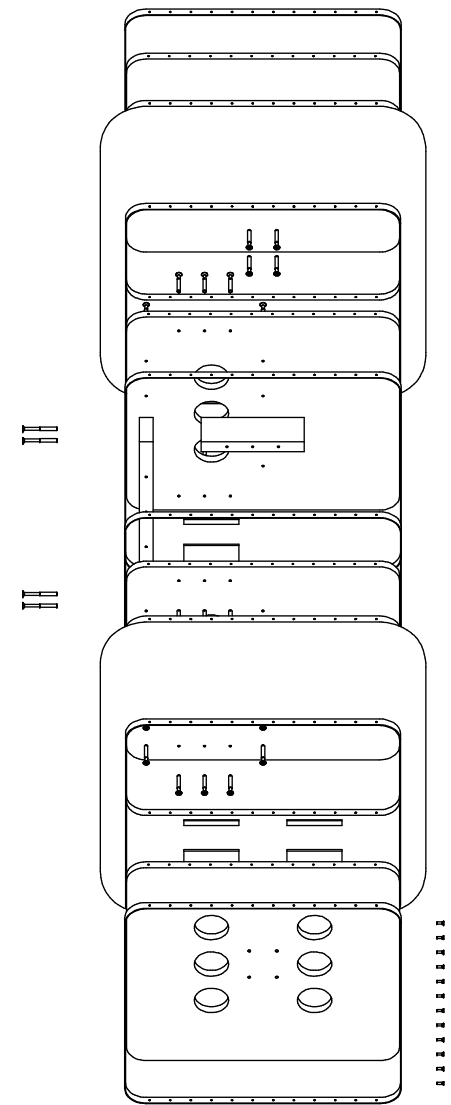
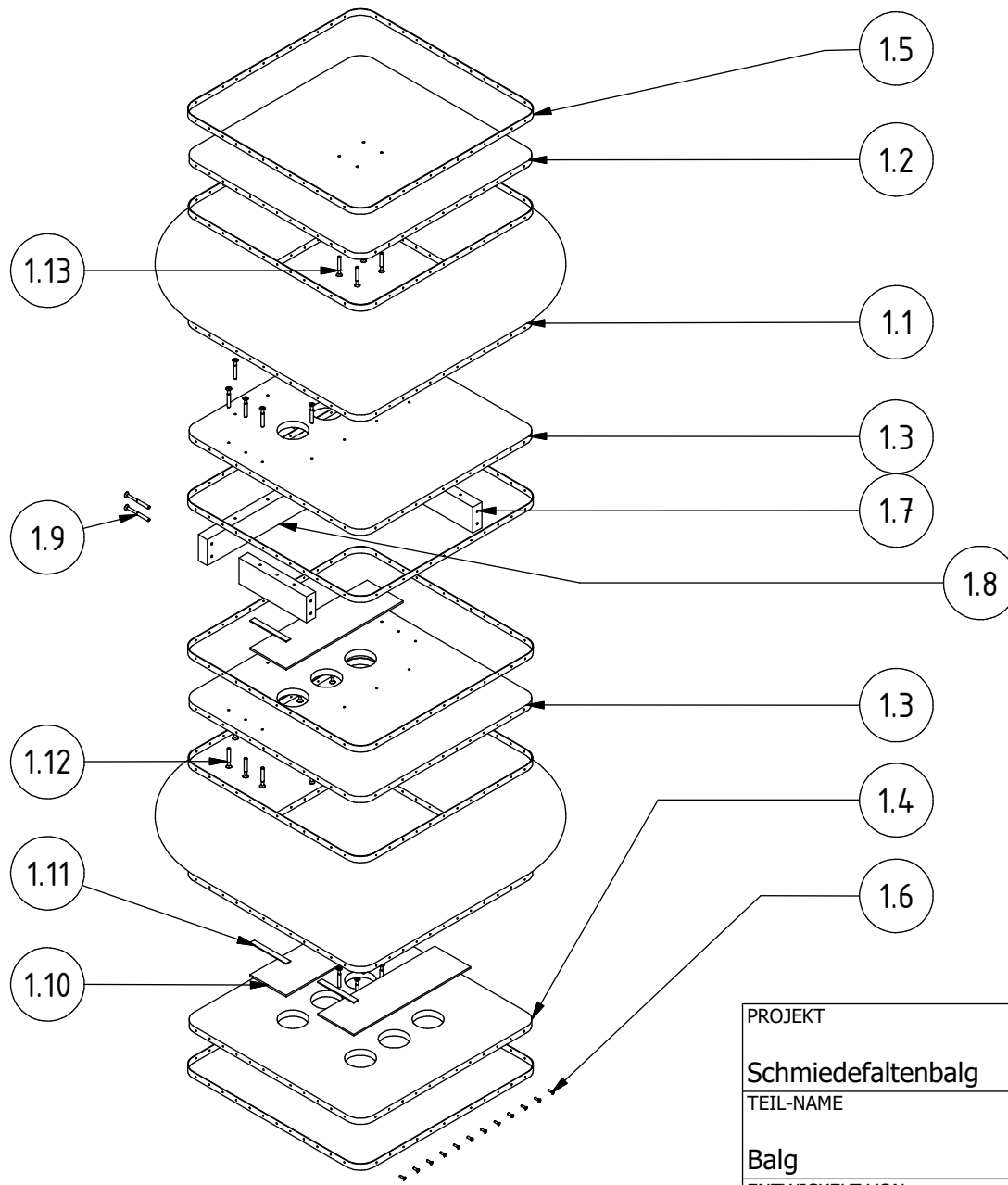

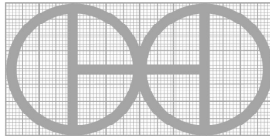
PROJEKT	ERSTELLT VON	GENEHMIGT VON	DATE	VERSION
Schmiedefaltenbalg	J. Zeron	A. Morillo	30/07/2021	1.0
TEIL-NAME	DATEI-NAME			TEIL-CODE
Balg	Bellows.ipn			1.0
ENTWICKELT VON	UMGESTALTET VON	DOK. TYP	WERKSTOFF	MENGE
University of Technology LAE Papua New Guinea	 OHO e.V.	Assembly		-
		LIZENZ	SCALE	SEITE
		CC-BY-SA 4.0	1:11	4 /22

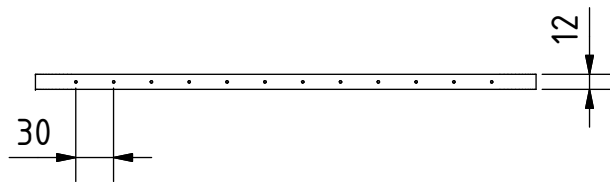
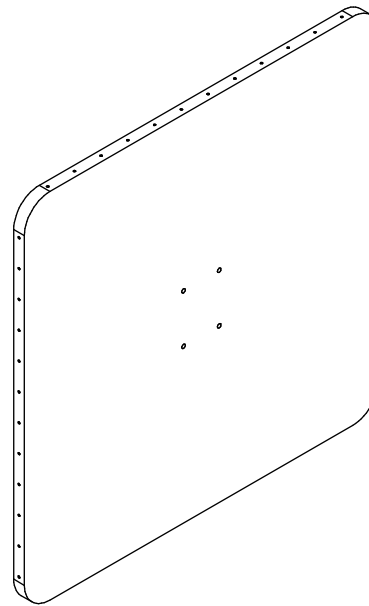
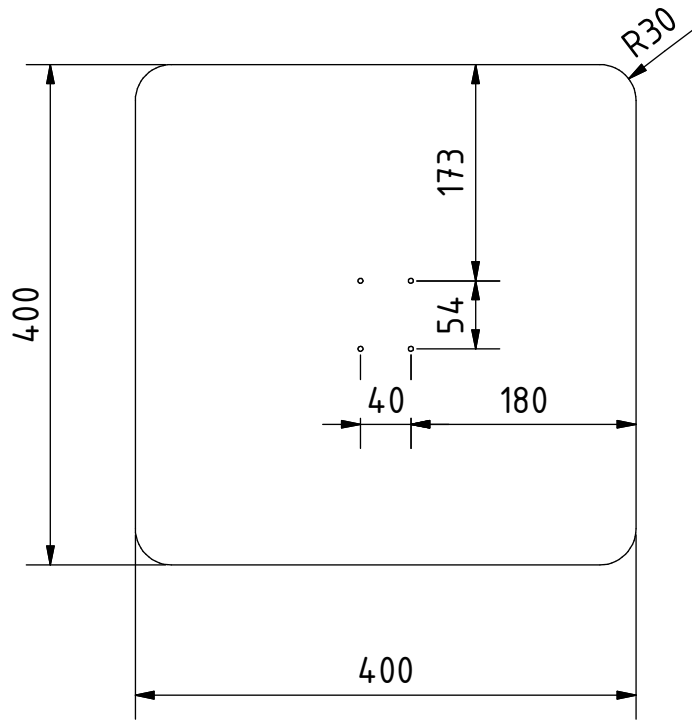

Hinweis: Alle einheiten in mm.

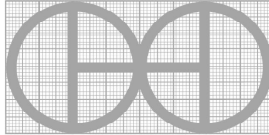
PROJEKT	ERSTELLT VON	GENEHMIGT VON	DATE	VERSION
Schmiedefaltenbalg	J. Zeron	A. Morillo	30/07/2021	1.0
TEIL-NAME	DATEI-NAME			TEIL-CODE
Quadratisches brett A	Square board A.ipt			1.2
ENTWICKELT VON	UMGESTALTET VON	DOK. TYP	WERKSTOFF	MENGE
University of Technology LAE Papua New Guinea	 OHO e.V.	Part	Sperrholz	1
		LIZENZ	SCALE	SEITE
		CC-BY-SA 4.0	1:6	5 /22

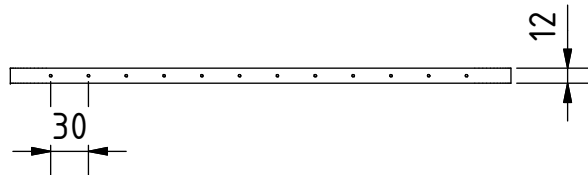
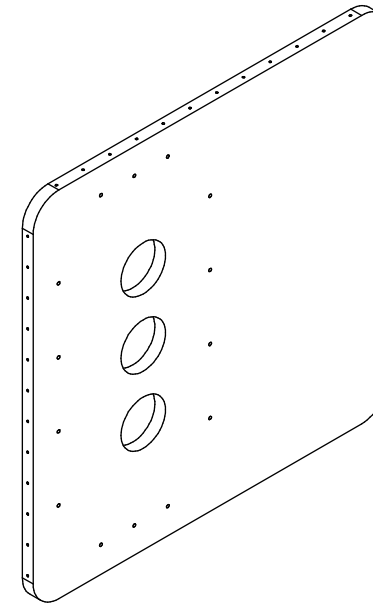
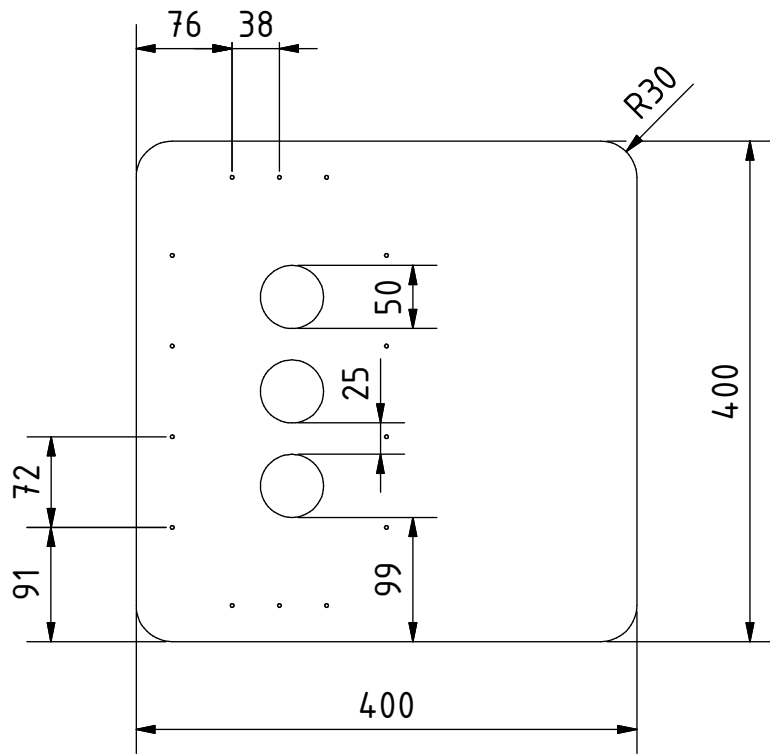

Hinweis: Alle einheiten in mm.

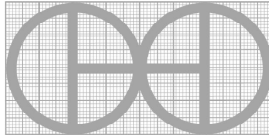
PROJEKT	ERSTELLT VON	GENEHMIGT VON	DATE	VERSION
Schmiedefaltenbalg	J. Zeron	A. Morillo	30/07/2021	1.0
TEIL-NAME	DATEI-NAME			TEIL-CODE
Quadratisches brett B	Square board B.ipt			1.3
ENTWICKELT VON	UMGESTALTET VON	DOK. TYP	WERKSTOFF	MENGE
University of Technology LAE Papua New Guinea	 OHO e.V.	Part	Sperrholz	2
		LIZENZ	SCALE	SEITE
		CC-BY-SA 4.0	1:6	6 /22

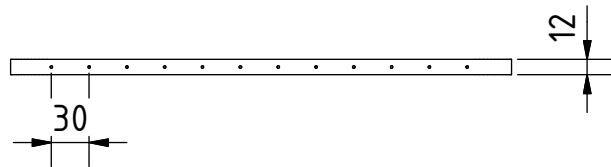
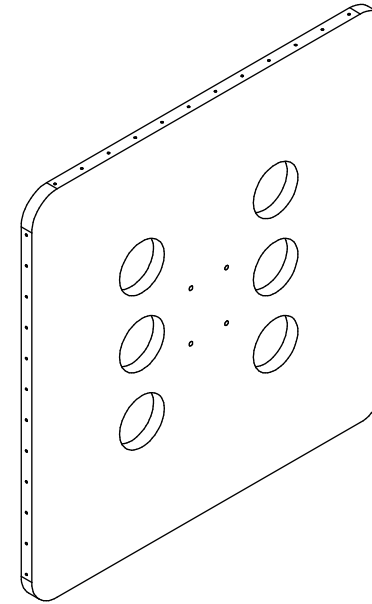
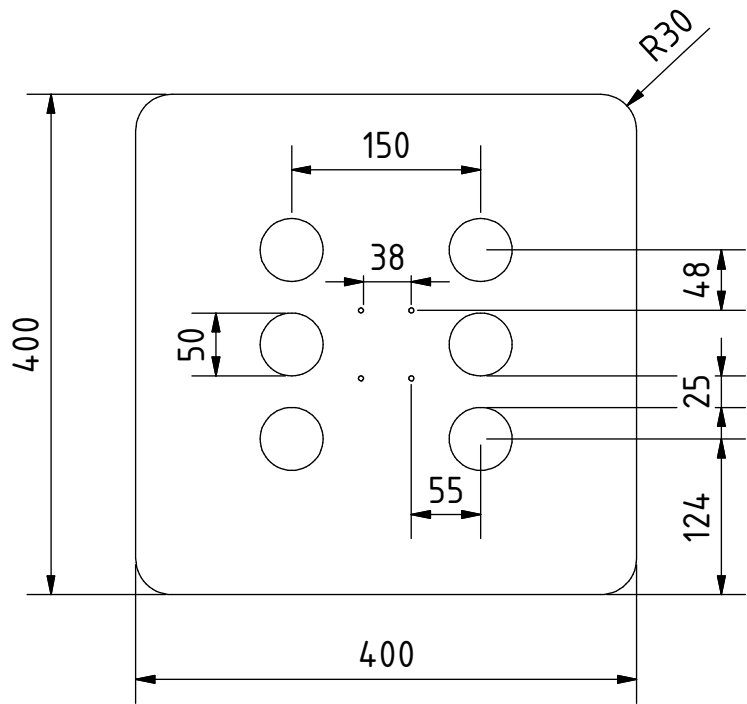

Hinweis: Alle einheiten in mm.

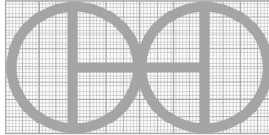
PROJEKT	ERSTELLT VON	GENEHMIGT VON	DATE	VERSION
Schmiedefaltenbalg	J. Zeron	A. Morillo	30/07/2021	1.0
TEIL-NAME	DATEI-NAME			TEIL-CODE
Quadratisches brett C	Square board C.ipt			1.4
ENTWICKELT VON	UMGESTALTET VON	DOK. TYP	WERKSTOFF	MENGE
University of Technology LAE Papua New Guinea	 OHO e.V.	Part	Sperrholz	1
		LIZENZ	SCALE	SEITE
		CC-BY-SA 4.0	1:6	7 /22

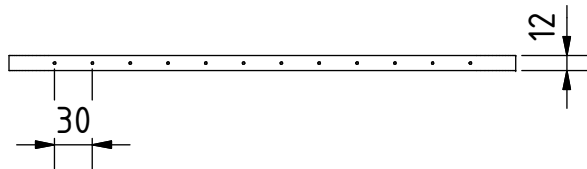
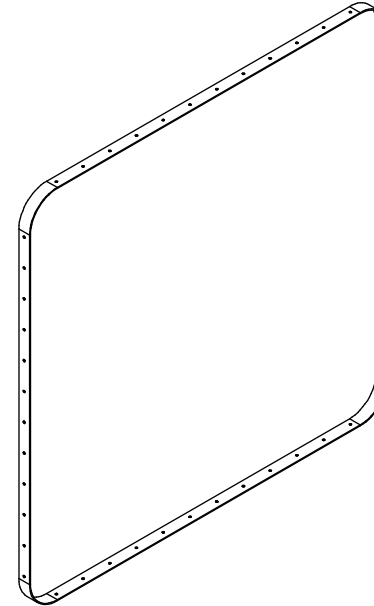
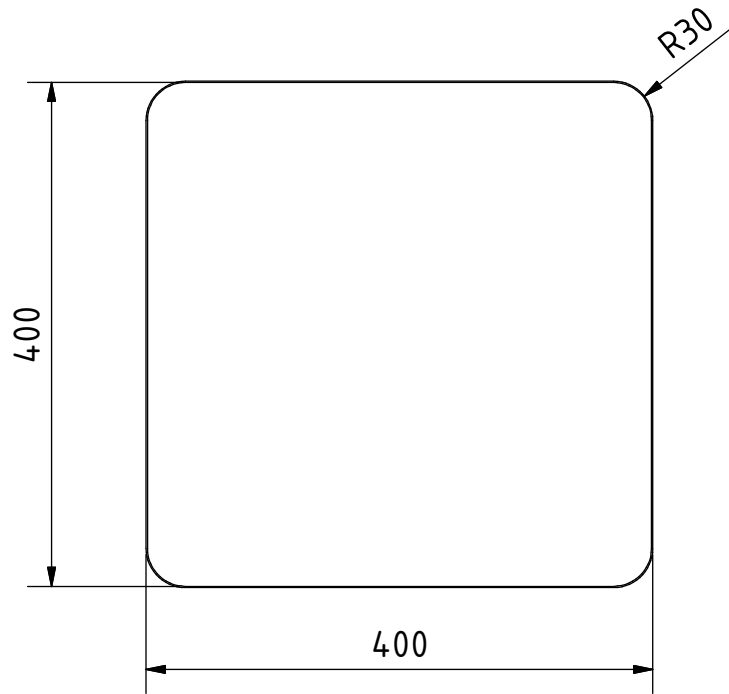

Hinweis: Alle einheiten in mm.

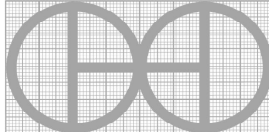
PROJEKT	ERSTELLT VON	GENEHMIGT VON	DATE	VERSION
Schmiedefaltenbalg	J. Zeron	A. Morillo	30/07/2021	1.0
TEIL-NAME	DATEI-NAME			TEIL-CODE
Blech	Sheet metal.ipt			1.5
ENTWICKELT VON	UMGESTALTET VON	DOK. TYP	WERKSTOFF	MENGE
		Part	Stahl C45	4
University of Technology LAE Papua New Guinea	OHO e.V.	LIZENZ	SCALE	SEITE
		CC-BY-SA 4.0	1:6	8 /22



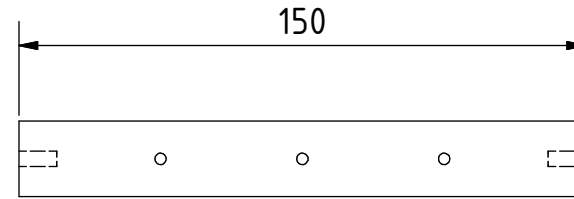
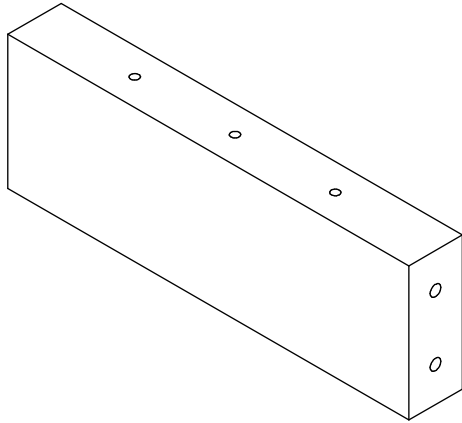
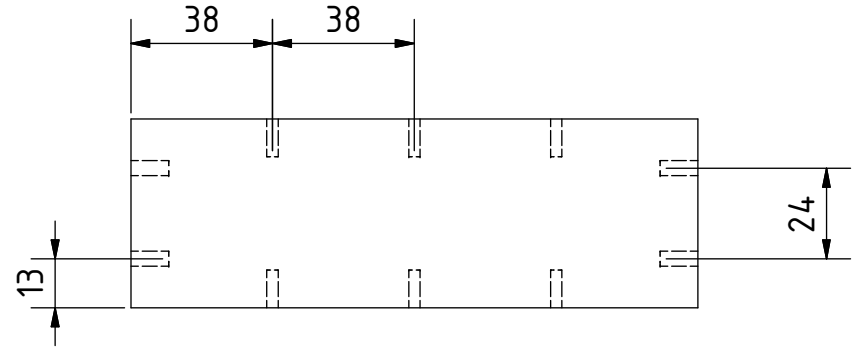
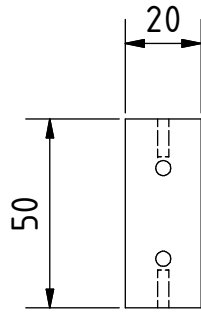

Hinweis: Alle einheiten in mm.

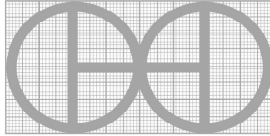
PROJEKT	ERSTELLT VON	GENEHMIGT VON	DATE	VERSION
Schmiedefaltenbalg	J. Zeron	A. Morillo	30/07/2021	1.0
TEIL-NAME	DATEI-NAME			TEIL-CODE
Buchsbaumholz A	Box timber A.ipt			1.7
ENTWICKELT VON	UMGESTALTET VON	DOK. TYP	WERKSTOFF	MENGE
University of Technology LAE Papua New Guinea	 OHO e.V.	Part	Hartholz	2
		LIZENZ	SCALE	SEITE
		CC-BY-SA 4.0	1:2	9 /22

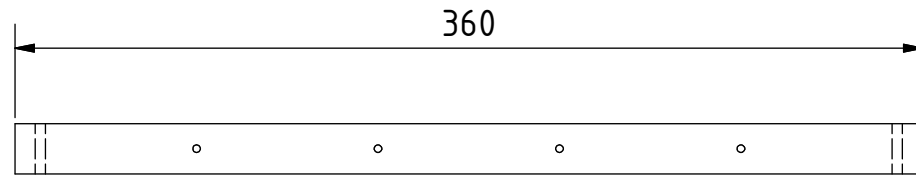
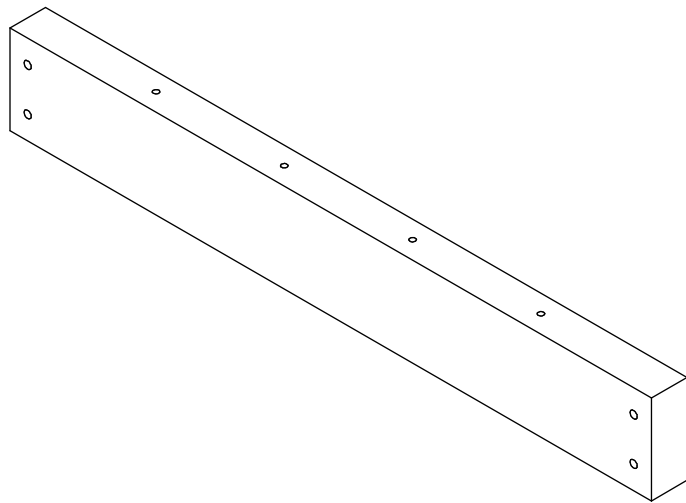
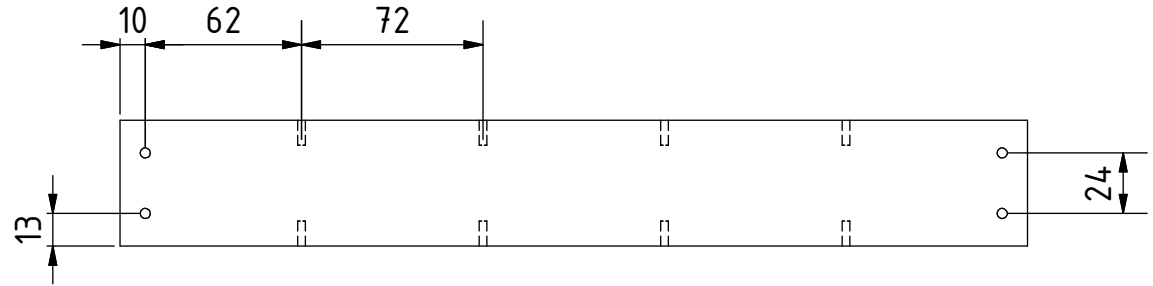
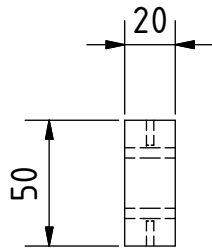

Hinweis: Alle einheiten in mm.

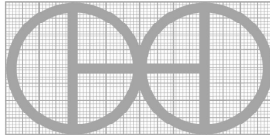
PROJEKT	ERSTELLT VON	GENEHMIGT VON	DATE	VERSION
Schmiedefaltenbalg	J. Zeron	A. Morillo	30/07/2021	1.0
TEIL-NAME	DATEI-NAME			TEIL-CODE
Buchsbaumholz B	Box timber B.ipt			1.8
ENTWICKELT VON	UMGESTALTET VON	DOK. TYP	WERKSTOFF	MENGE
University of Technology LAE Papua New Guinea	 OHO e.V.	Part	Hartholz	1
		LIZENZ	SCALE	SEITE
		CC-BY-SA 4.0	1:3	10 /22

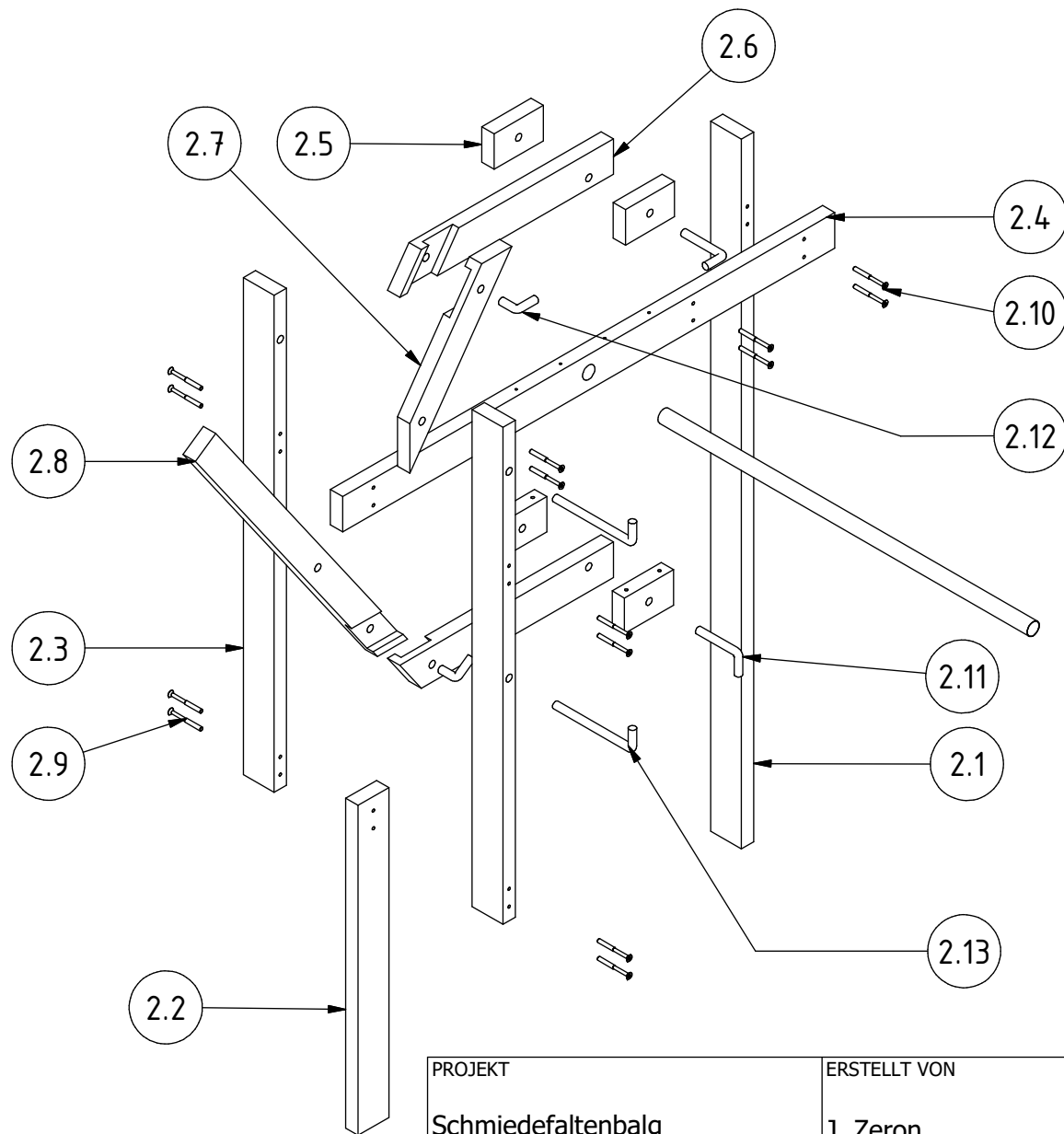

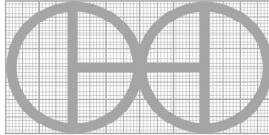
PROJEKT	ERSTELLT VON	GENEHMIGT VON	DATE	VERSION
Schmiedefaltenbalg	J. Zeron	A. Morillo	30/07/2021	1.0
TEIL-NAME	DATEI-NAME			TEIL-CODE
Rahmen	Frame.ipn			2.0
ENTWICKELT VON	UMGESTALTET VON	DOK. TYP	WERKSTOFF	MENGE
		Assembly		-
University of Technology LAE Papua New Guinea	OHO e.V.	LIZENZ	SCALE	SEITE
		CC-BY-SA 4.0	1:8	11 /22

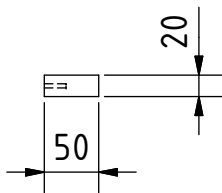
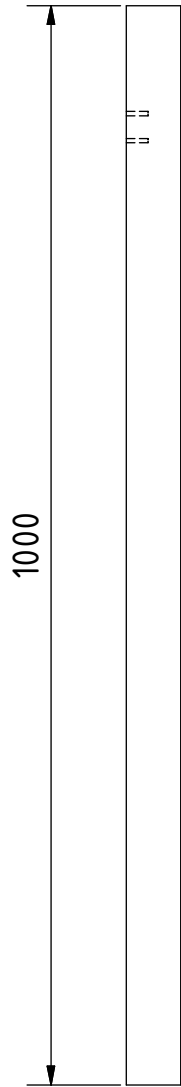

Hinweis: Alle einheiten in mm.

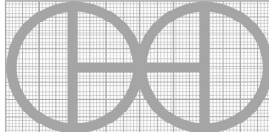
PROJEKT	ERSTELLT VON	GENEHMIGT VON	DATE	VERSION
Schmiedefaltenbalg	J. Zeron	A. Morillo	30/07/2021	1.0
TEIL-NAME	DATEI-NAME			TEIL-CODE
Fub A	Foot A.ipt			2.1
ENTWICKELT VON	UMGESTALTET VON	DOK. TYP	WERKSTOFF	MENGE
University of Technology LAE Papua New Guinea	 OHO e.V.	Part	Hartholz	1
		LIZENZ	SCALE	SEITE
		CC-BY-SA 4.0	1:7	12 /22

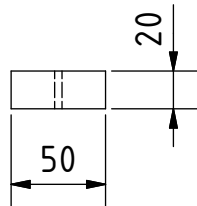
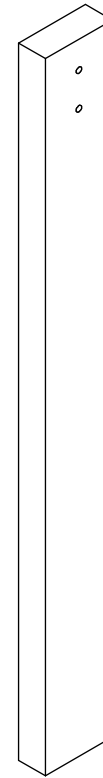
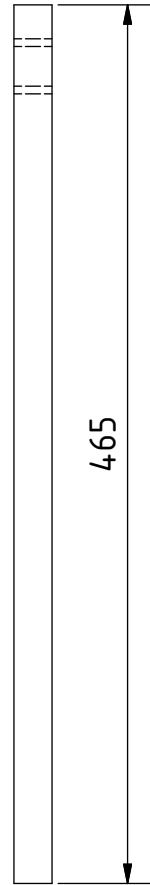
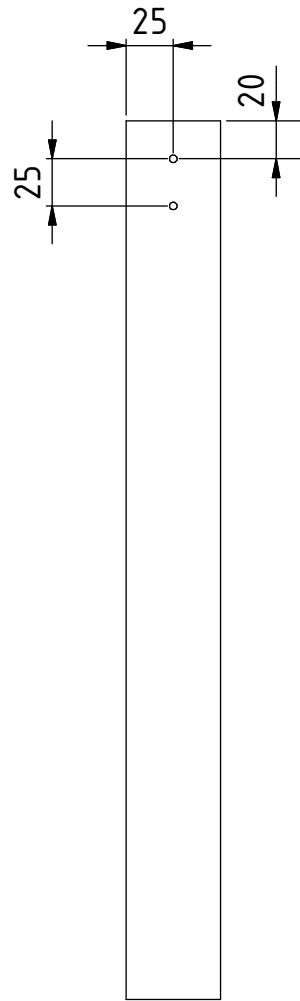

Hinweis: Alle einheiten in mm.

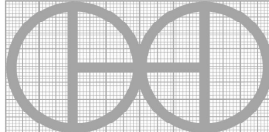
PROJEKT	ERSTELLT VON	GENEHMIGT VON	DATE	VERSION
Schmiedefaltenbalg	J. Zeron	A. Morillo	30/07/2021	1.0
TEIL-NAME	DATEI-NAME			TEIL-CODE
Fub B	Foot B.ipt			2.2
ENTWICKELT VON	UMGESTALTET VON	DOK. TYP	WERKSTOFF	MENGE
		Part	Hartholz	1
University of Technology LAE Papua New Guinea	OHO e.V.	LIZENZ	SCALE	SEITE
		CC-BY-SA 4.0	1:4	13 /22

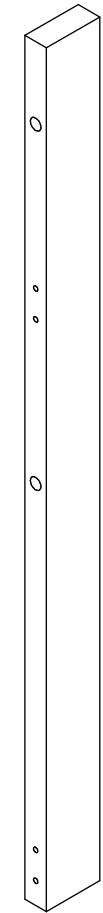
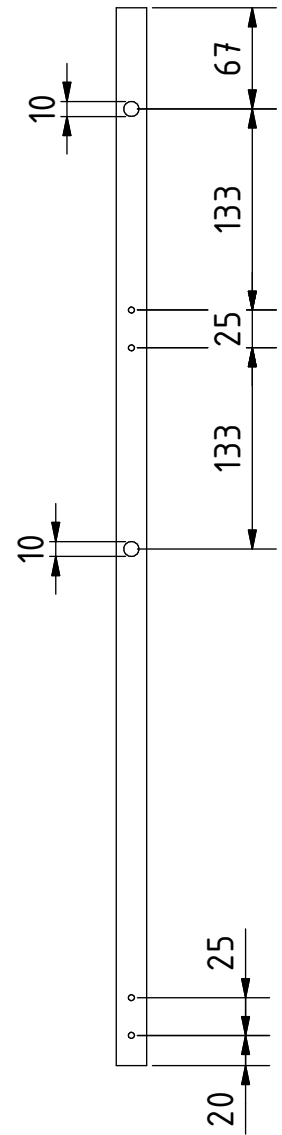
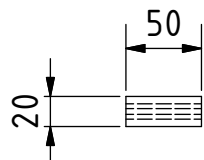
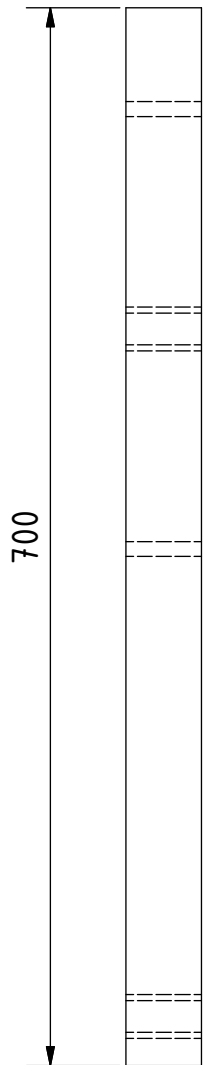

Hinweis: Alle einheiten in mm.

PROJEKT	ERSTELLT VON	GENEHMIGT VON	DATE	VERSION
Schmiedefaltenbalg	J. Zeron	A. Morillo	30/07/2021	1.0
TEIL-NAME	DATEI-NAME			TEIL-CODE
Fub C	Foot C.ipt			2.3
ENTWICKELT VON	UMGESTALTET VON	DOK. TYP	WERKSTOFF	MENGE
University of Technology LAE Papua New Guinea	 OHO e.V.	Part	Hartholz	2
		LIZENZ	SCALE	SEITE
		CC-BY-SA 4.0	1:5	14 /22

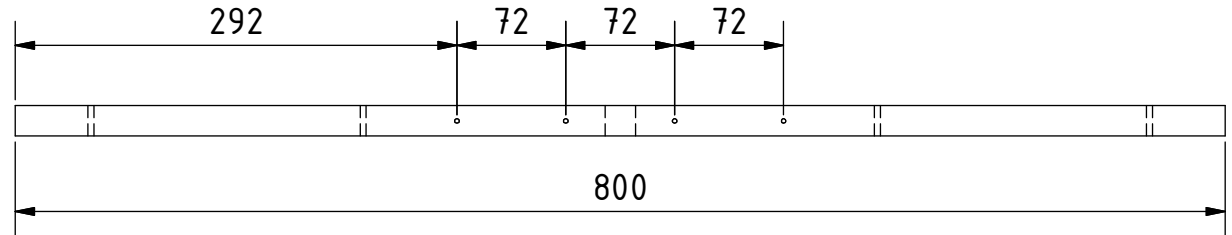
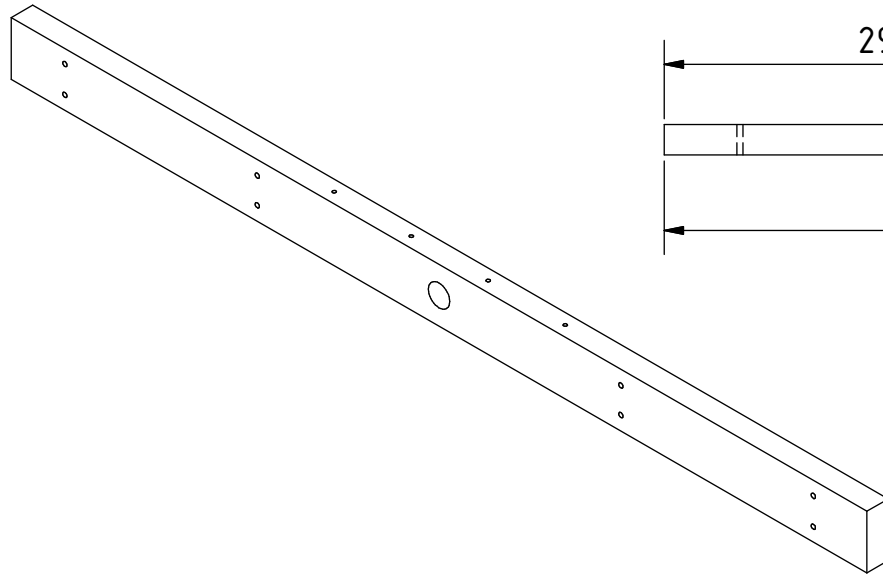
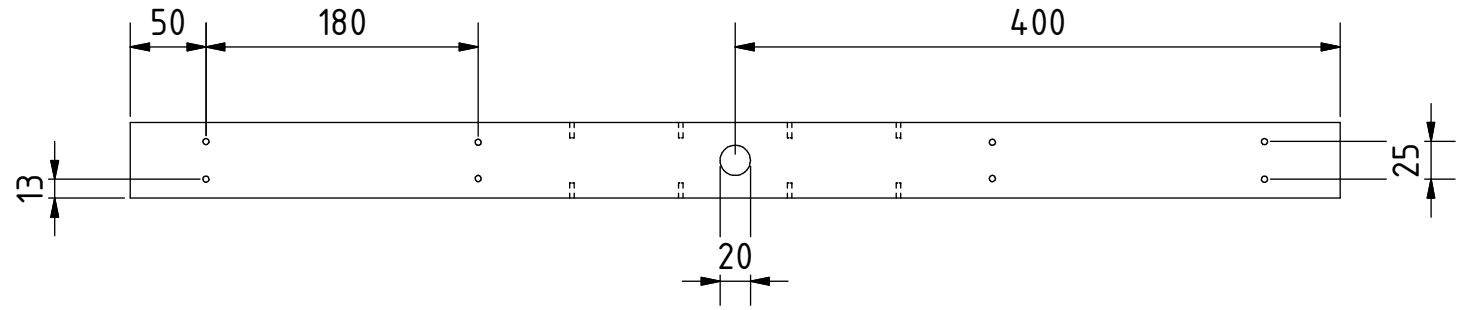
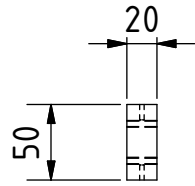

Hinweis: Alle einheiten in mm.

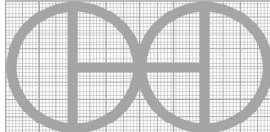
PROJEKT	ERSTELLT VON	GENEHMIGT VON	DATE	VERSION
Schmiedefaltenbalg	J. Zeron	A. Morillo	30/07/2021	1.0
TEIL-NAME	DATEI-NAME	TEIL-CODE		
Buchsbaumholz C	Box timber C.ipt	2.4		
ENTWICKELT VON	UMGESTALTET VON	DOK. TYP	WERKSTOFF	MENGE
University of Technology LAE Papua New Guinea	 OHO e.V.	Part	Hartholz	1
		LIZENZ	SCALE	SEITE
		CC-BY-SA 4.0	1:5	15 /22

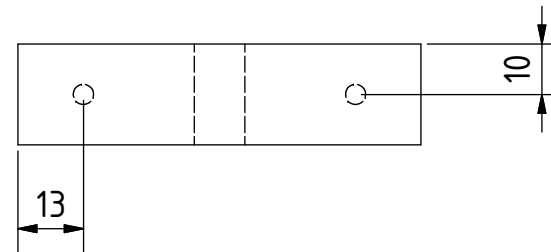
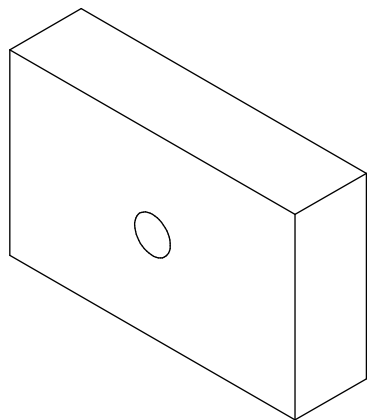
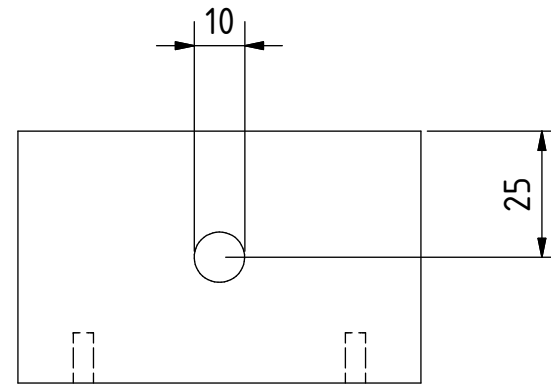
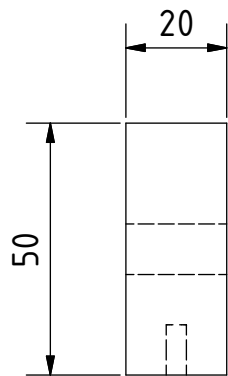

Hinweis: Alle einheiten in mm.

PROJEKT	ERSTELLT VON	GENEHMIGT VON	DATE	VERSION
Schmiedefaltenbalg	J. Zeron	A. Morillo	30/07/2021	1.0
TEIL-NAME	DATEI-NAME			TEIL-CODE
Kleinholz	Small timber.ipt			2.5
ENTWICKELT VON	UMGESTALTET VON	DOK. TYP	WERKSTOFF	MENGE
University of Technology LAE Papua New Guinea	 OHO e.V.	Part	Hartholz	4
		LIZENZ	SCALE	SEITE
		CC-BY-SA 4.0	1:1.5	16 /22



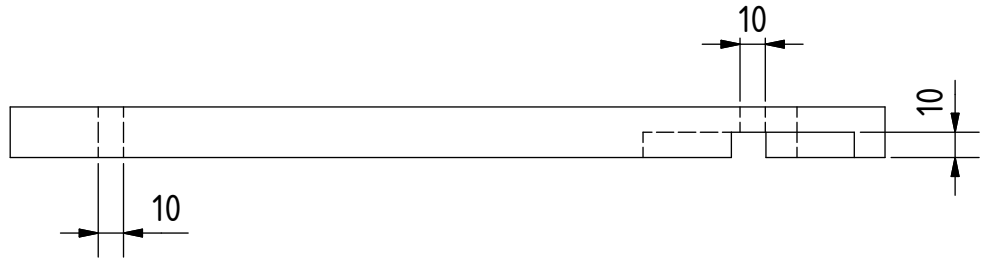
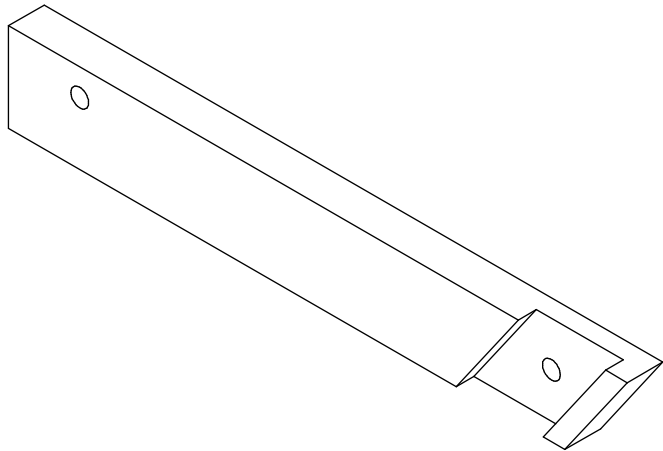
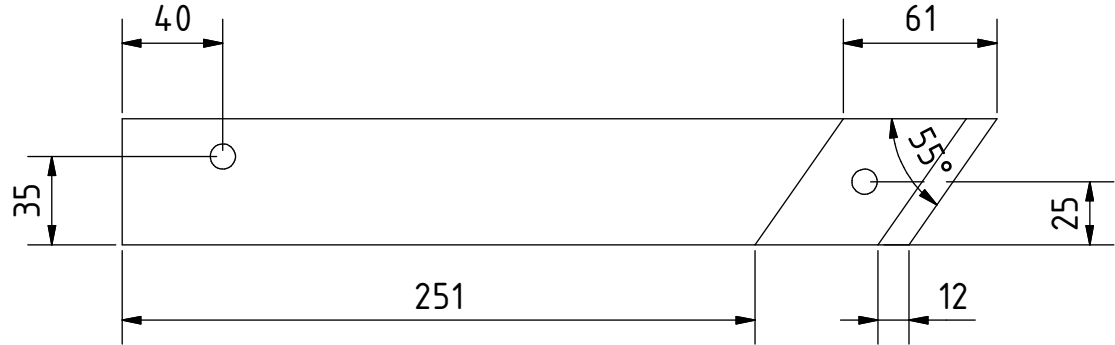
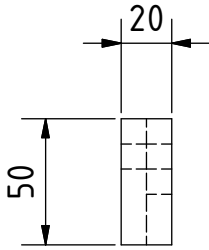

Hinweis: Alle einheiten in mm.

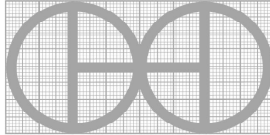
PROJEKT	ERSTELLT VON	GENEHMIGT VON	DATE	VERSION
Schmiedefaltenbalg	J. Zeron	A. Morillo	30/07/2021	1.0
TEIL-NAME	DATEI-NAME			TEIL-CODE
Arm A	Arm A.ipt			2.6
ENTWICKELT VON	UMGESTALTET VON	DOK. TYP	WERKSTOFF	MENGE
University of Technology LAE Papua New Guinea	 OHO e.V.	Part	Hartholz	2
		LIZENZ	SCALE	SEITE
		CC-BY-SA 4.0	1:3	17 /22

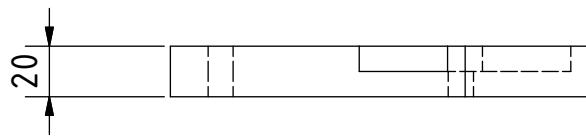
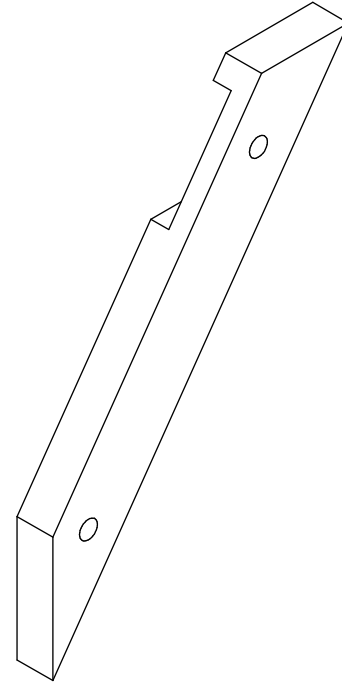
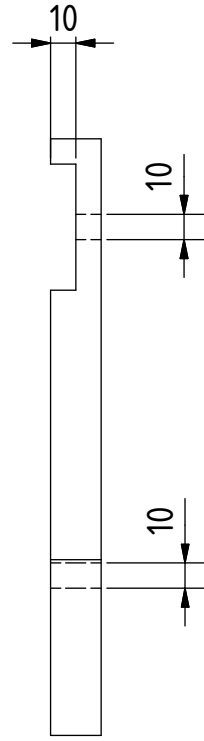
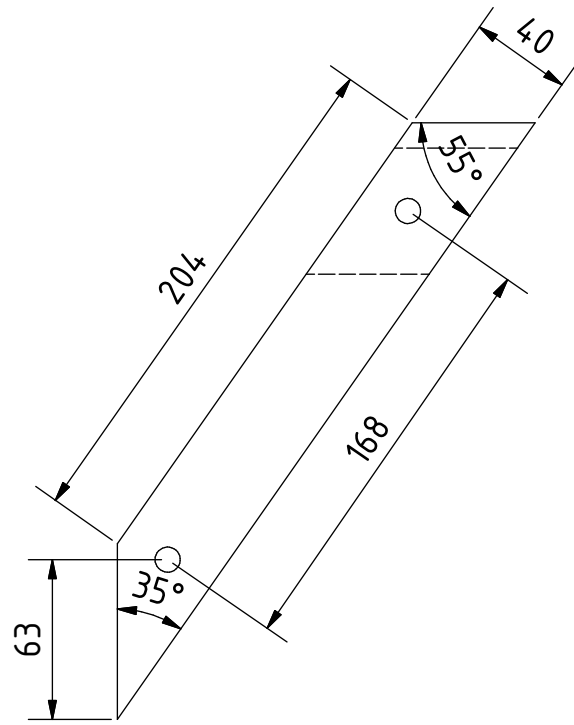

Hinweis: Alle einheiten in mm.

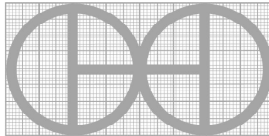
PROJEKT	ERSTELLT VON	GENEHMIGT VON	DATE	VERSION
Schmiedefaltenbalg	J. Zeron	A. Morillo	30/07/2021	1.0
TEIL-NAME	DATEI-NAME			TEIL-CODE
Arm B	Arm B.ipt			2.7
ENTWICKELT VON	UMGESTALTET VON	DOK. TYP	WERKSTOFF	MENGE
		Part	Hartholz	1
University of Technology LAE Papua New Guinea	OHO e.V.	LIZENZ	SCALE	SEITE
		CC-BY-SA 4.0	1:3	18 /22

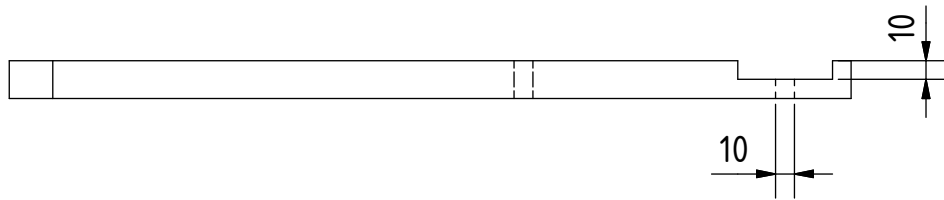
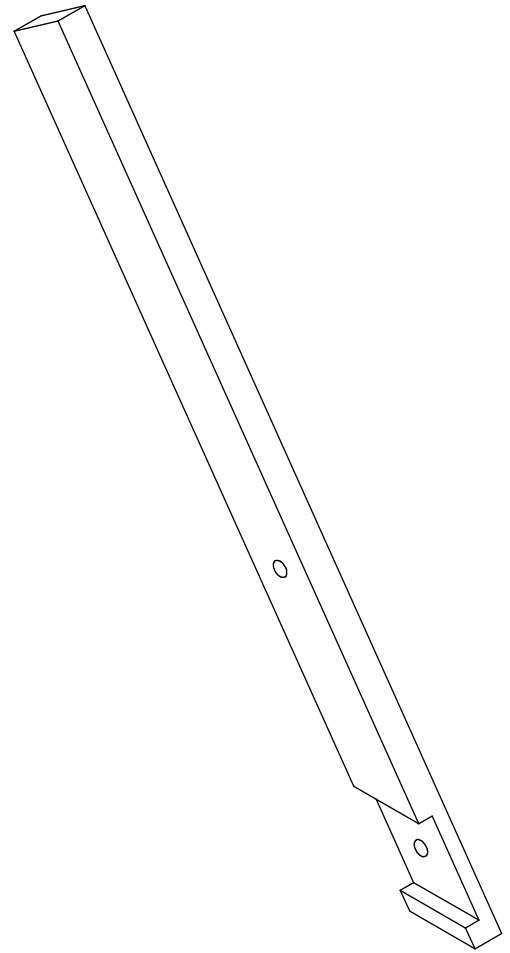
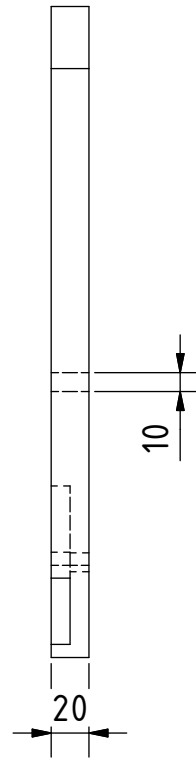
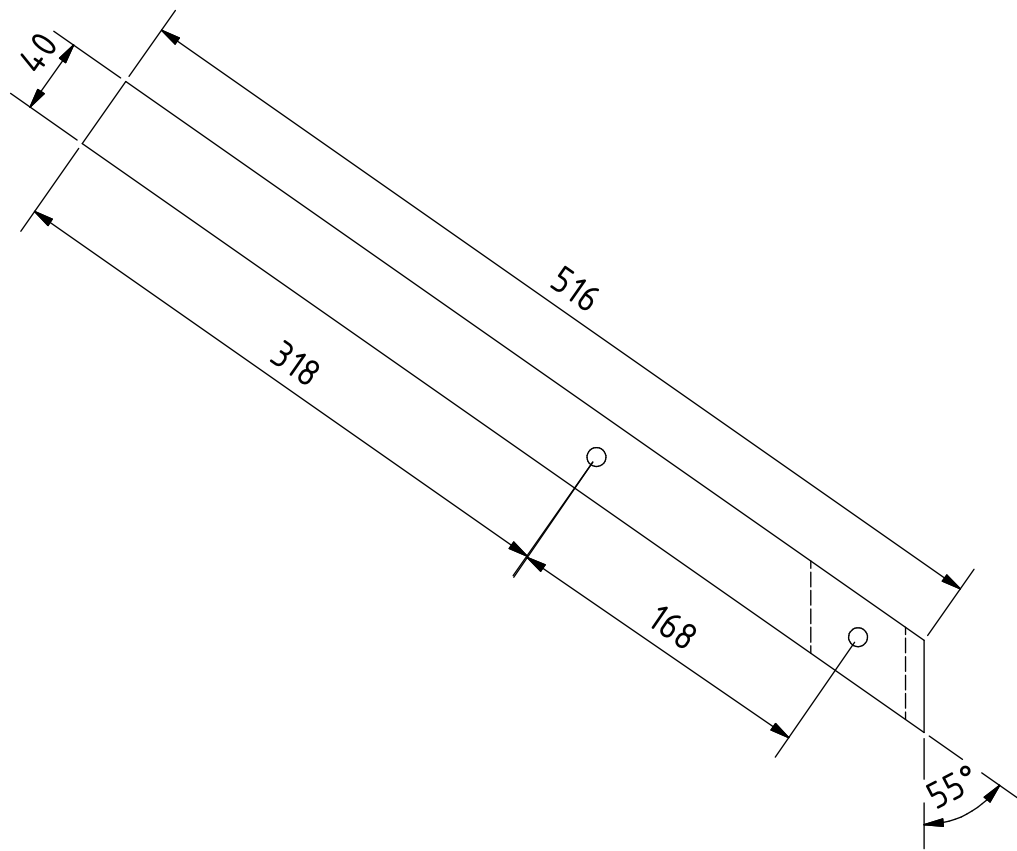

Hinweis: Alle einheiten in mm.

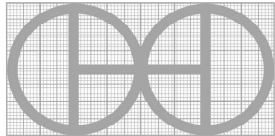
PROJEKT	ERSTELLT VON	GENEHMIGT VON	DATE	VERSION
Schmiedefaltenbalg	J. Zeron	A. Morillo	30/07/2021	1.0
TEIL-NAME	DATEI-NAME			TEIL-CODE
Arm C	Arm C.ipt			2.8
ENTWICKELT VON	UMGESTALTET VON	DOK. TYP	WERKSTOFF	MENGE
		Part	Hartholz	1
University of Technology LAE Papua New Guinea	OHO e.V.	LIZENZ	SCALE	SEITE
		CC-BY-SA 4.0	1:4	19 /22

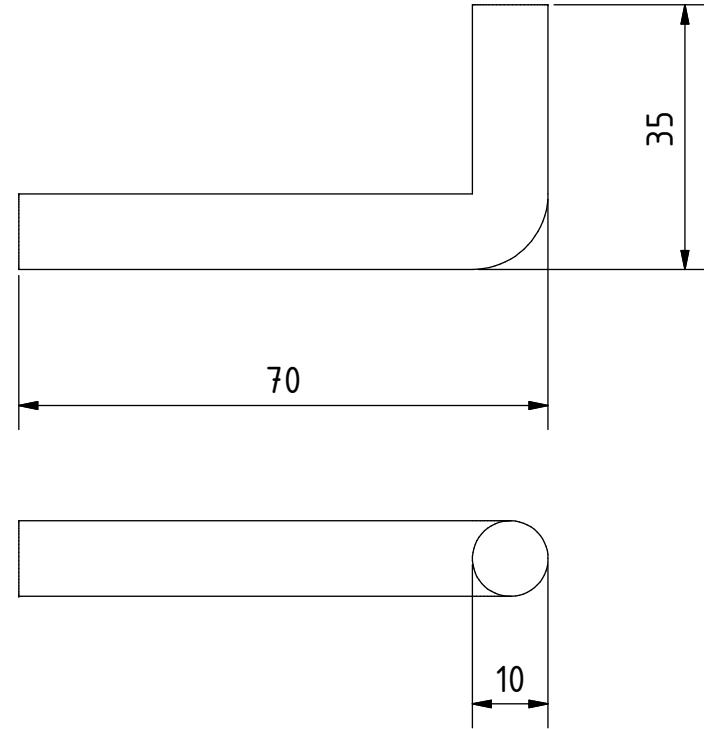
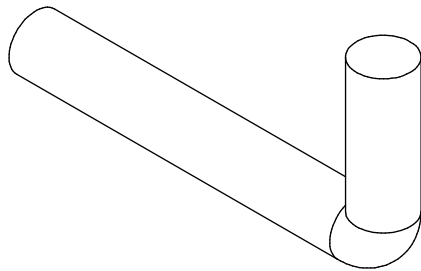

Hinweis: Alle einheiten in mm.

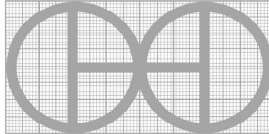
PROJEKT	ERSTELLT VON	GENEHMIGT VON	DATE	VERSION
Schmiedefaltenbalg	J. Zeron	A. Morillo	30/07/2021	1.0
TEIL-NAME	DATEI-NAME			TEIL-CODE
Stift A	Pin A.ipt			2.11
ENTWICKELT VON	UMGESTALTET VON	DOK. TYP	WERKSTOFF	MENGE
University of Technology LAE Papua New Guinea	 OHO e.V.	Part	Stahl A36	2
		LIZENZ	SCALE	SEITE
		CC-BY-SA 4.0	1:1	20 /22

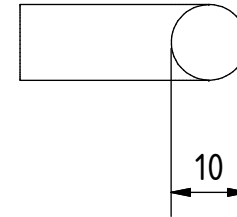
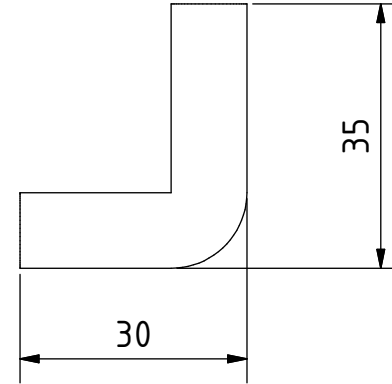
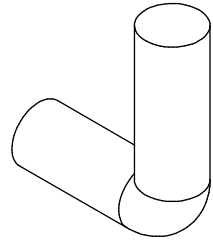

Hinweis: Alle einheiten in mm.

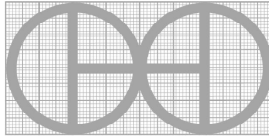
PROJEKT	ERSTELLT VON	GENEHMIGT VON	DATE	VERSION
Schmiedefaltenbalg	J. Zeron	A. Morillo	30/07/2021	1.0
TEIL-NAME	DATEI-NAME			TEIL-CODE
Stift B	Pin B.ipt			2.12
ENTWICKELT VON	UMGESTALTET VON	DOK. TYP	WERKSTOFF	MENGE
University of Technology LAE Papua New Guinea	 OHO e.V.	Part	Stahl A36	2
		LIZENZ	SCALE	SEITE
		CC-BY-SA 4.0	1:1	21 /22

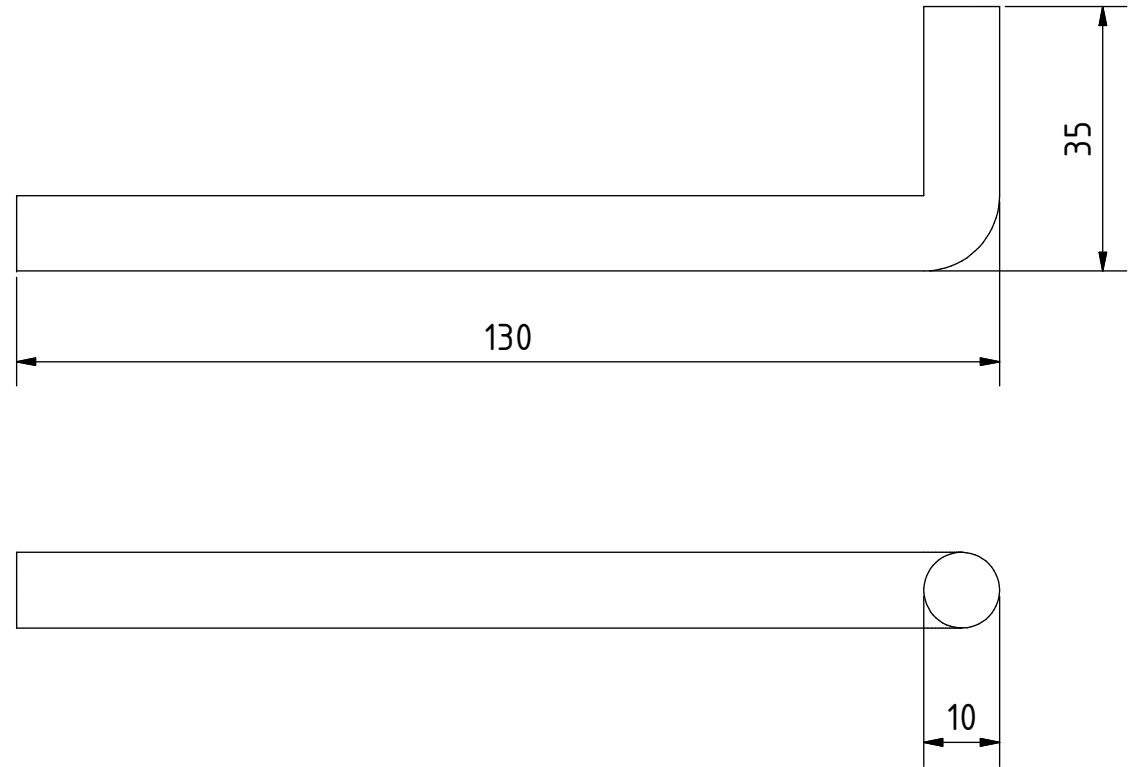
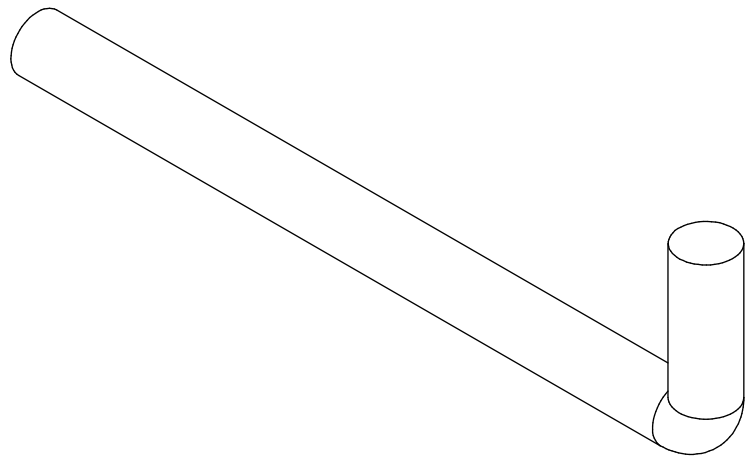

Hinweis: Alle einheiten in mm.

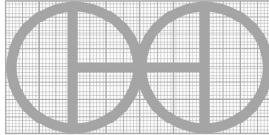
PROJEKT	ERSTELLT VON	GENEHMIGT VON	DATE	VERSION
Schmiedefaltenbalg	J. Zeron	A. Morillo	30/07/2021	1.0
TEIL-NAME	DATEI-NAME			TEIL-CODE
Stift C	Pin C.ipt			2.13
ENTWICKELT VON	UMGESTALTET VON	DOK. TYP	WERKSTOFF	MENGE
		Part	Stahl A36	2
University of Technology LAE Papua New Guinea	OHO e.V.	LIZENZ	SCALE	SEITE
		CC-BY-SA 4.0	1:1	22 /22