

PROJECT		CREATED BY		APPROVED BY		DATE		VERSION	
Nest box for rabbits		E. CEBALLOS		A. MORILLO		24-05-2021		1.0	
PART NAME		FILE NAME						PART CODE	
Nest box for rabbits		nest-box-rabbit.iam						A1	
DEVELOPED BY		REDESIGNED BY		SUPPORTED BY		DOC. TYPE		MATERIAL	
						ASSEMBLY			
Rodale Press		OHO e.V.				LICENCE		SCALE	
						CC-BY-SA 4.0		1:8	
								QUANTITY	
								1	
								SHEET	
								1 / 8	

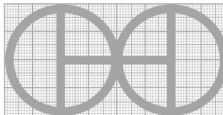
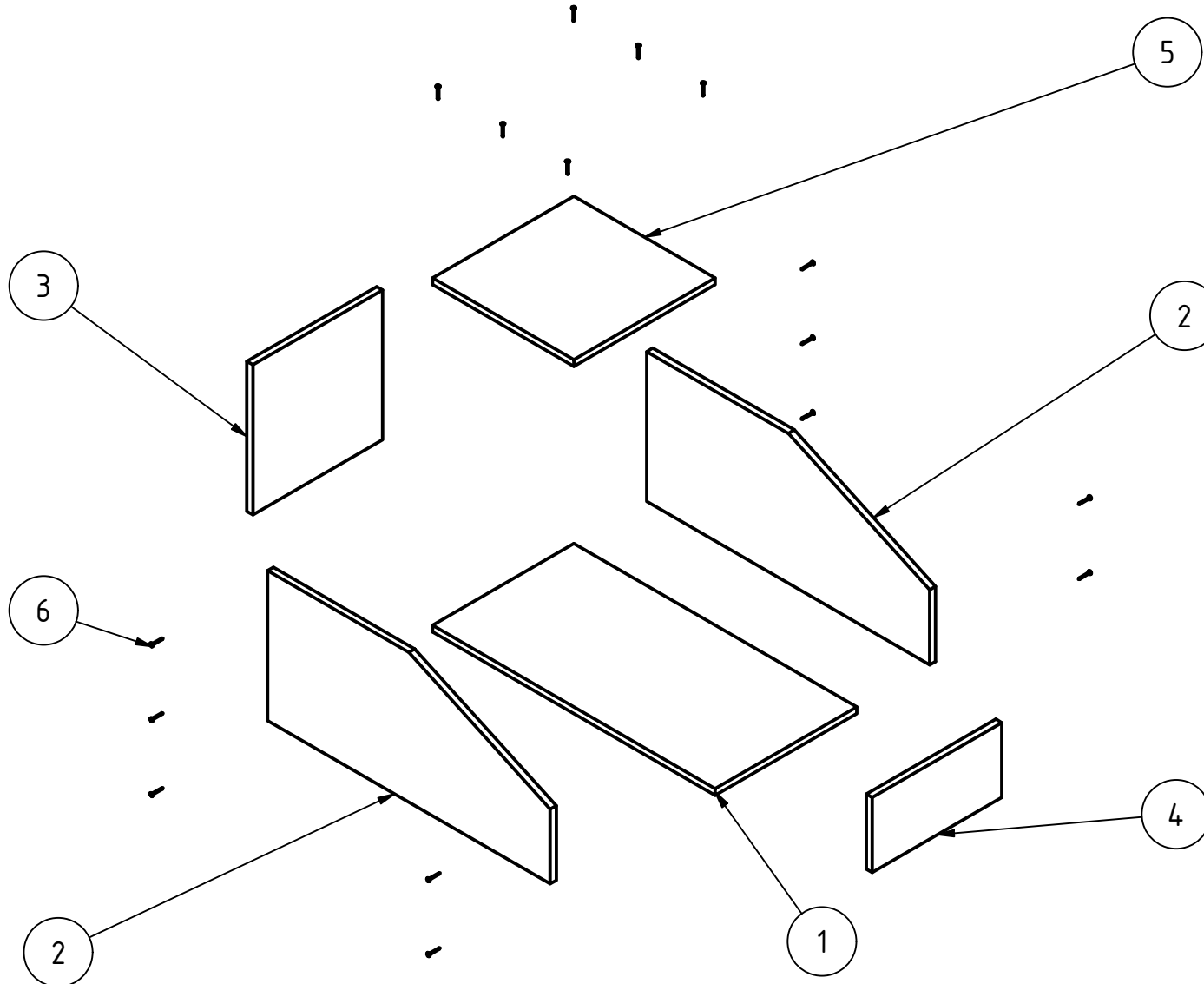
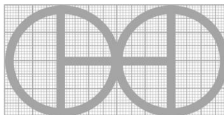
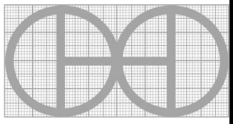

PROJECT		CREATED BY	APPROVED BY	DATE	VERSION
Nest box for rabbits		E. CEBALLOS	A. MORILLO	24-05-2021	1.0
PART NAME		FILE NAME			PART CODE
Nest box for rabbits		nest-box-rabbits.ipn			A2
DEVELOPED BY	REDESIGNED BY	SUPPORTED BY	DOC. TYPE	MATERIAL	QUANTITY
			ASSEMBLY		1
			LICENCE	SCALE	SHEET
Rodale Press	OHO e.V.		CC-BY-SA 4.0	1:10	2 / 8

PART LIST							
POS	POS.OLD	QTY	PART NAME	FILE NAME	PART TYPE	SPECIFICATIONS	SHEET
A			Nest Box	Proyecto OHO AF-AH_A1_P1 05-261 Kleinvieh_P41.iam			1-2
B			Part List				3
1		1	Base table	Base table.ipt	Production	Kiln-dried pine, thickness 1/2 "	4
2		2	side table	side table.ipt	Production	Kiln-dried pine, thickness 1/2 "	5
3		1	back table	back table.ipt	Production	Kiln-dried pine, thickness 1/2 "	6
4		1	front table	front table.ipt	Production	Kiln-dried pine, thickness 1/2 "	7
5		1	upper table	upper table.ipt	Production	Kiln-dried pine, thickness 1/2 "	8
6		16	Nail	Nail.ipt	Standard	Steel ASTM F-1667, Nail 1"	

PROJECT		CREATED BY	APPROVED BY	DATE	VERSION
Nest box for rabbits		E. CEBALLOS	A. MORILLO	24-05-2021	1.0
PART NAME		FILE NAME			PART CODE
PART LIST					B1
DEVELOPED BY	REDESIGNED BY	SUPPORTED BY	DOC. TYPE	MATERIAL	QUANTITY
			PART LIST		
Rodale Press		OHO e.V.	LICENCE	SCALE	SHEET
			CC-BY-SA 4.0		3 / 8

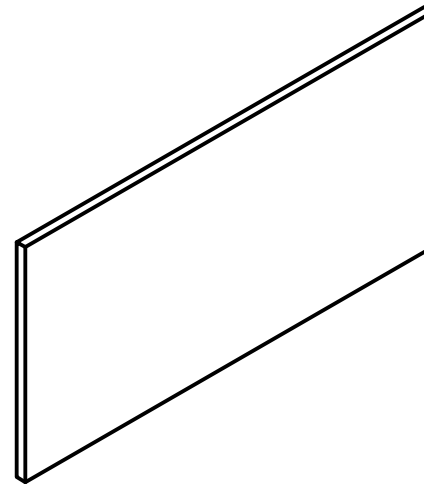
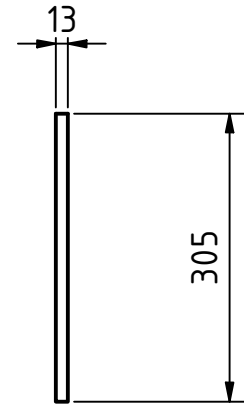
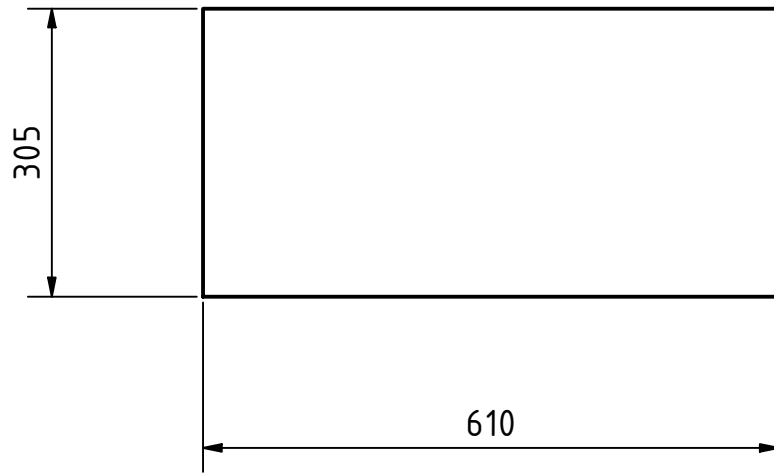

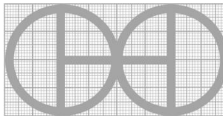
PROJECT		CREATED BY		APPROVED BY		DATE		VERSION	
Nest box for rabbits		E. CEBALLOS		A. MORILLO		24-05-2021		1.0	
PART NAME				FILE NAME				PART CODE	
Base table				Base table.ipt				1	
DEVELOPED BY		REDESIGNED BY		SUPPORTED BY		DOC. TYPE		MATERIAL	
						PART		Kilndried pine, thickness 1/2"	
Rodale Press		OHO e.V.				LICENCE		SCALE	
						CC-BY-SA 4.0		1:8	
								QUANTITY	
								1	
								SHEET	
								4 / 8	

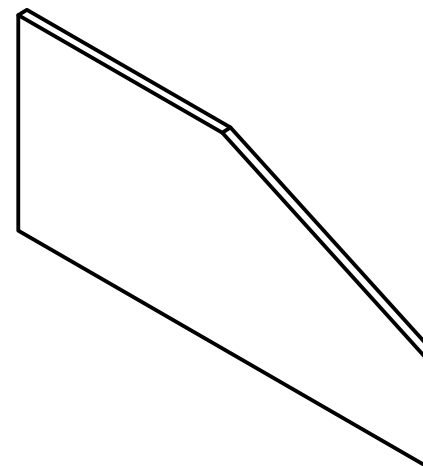
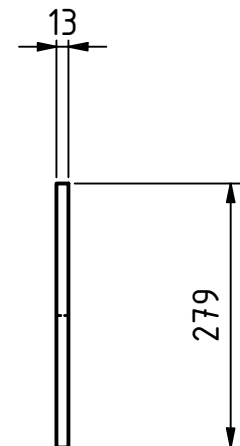
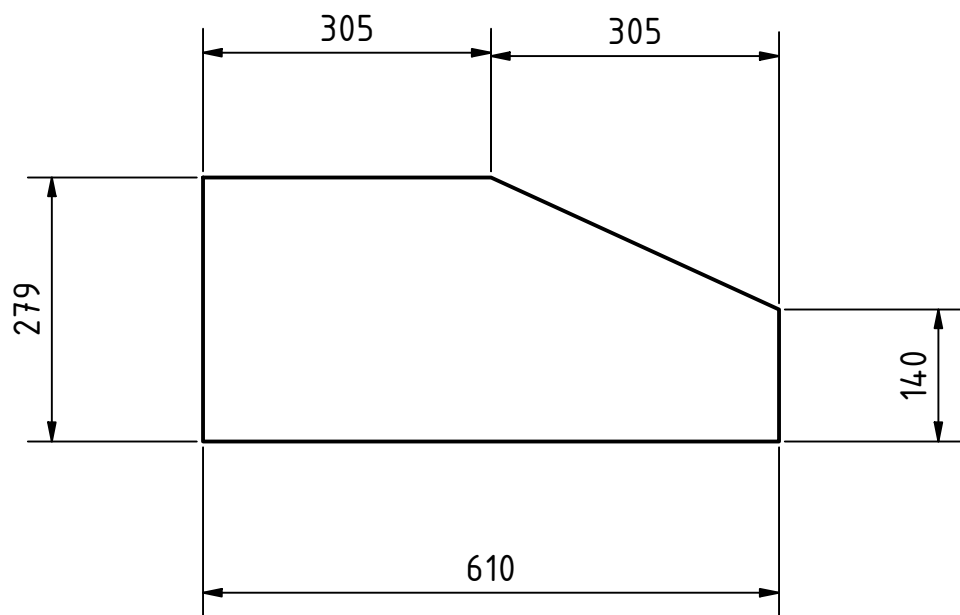

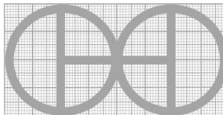
PROJECT		CREATED BY	APPROVED BY	DATE	VERSION
Nest box for rabbits		E. CEBALLOS	A. MORILLO	24-05-2021	1.0
PART NAME		FILE NAME			PART CODE
side table		side table.ipt			2
DEVELOPED BY	REDESIGNED BY	SUPPORTED BY	DOC. TYPE	MATERIAL	QUANTITY
			PART	Kiln-dried pine, thickness 1/2"	2
			LICENCE	SCALE	SHEET
Rodale Press	OHO e.V.		CC-BY-SA 4.0	1:8	5 / 8

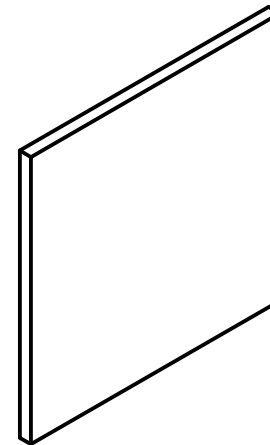
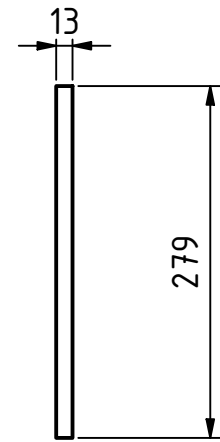
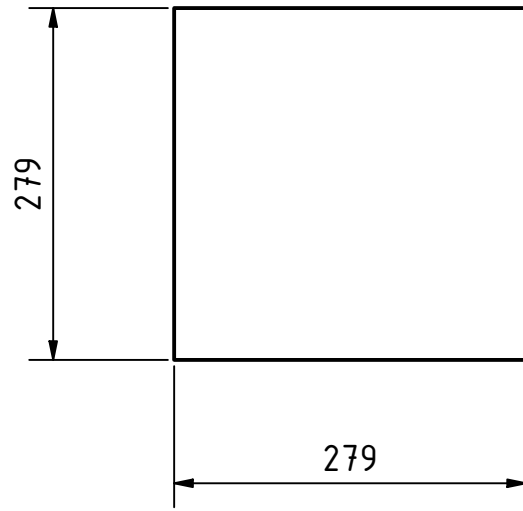

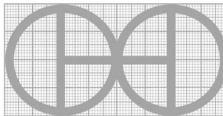
PROJECT		CREATED BY	APPROVED BY	DATE	VERSION
Nest box for rabbits		E. CEBALLOS	A. MORILLO	24-05-2021	1.0
PART NAME		FILE NAME			PART CODE
back table		back table.ipt			3
DEVELOPED BY	REDESIGNED BY	SUPPORTED BY	DOC. TYPE	MATERIAL	QUANTITY
			PART	Kiln-dried pine, thickness 1/2"	1
			LICENCE	SCALE	SHEET
Rodale Press	OHO e.V.		CC-BY-SA 4.0	1:6	6 / 8

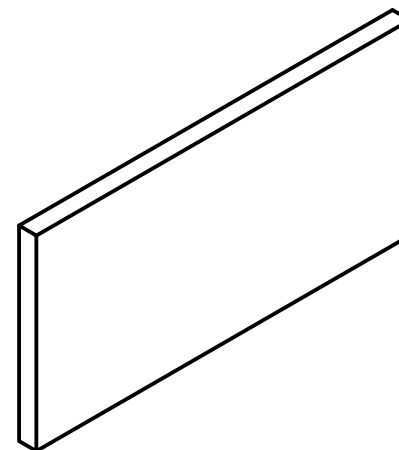
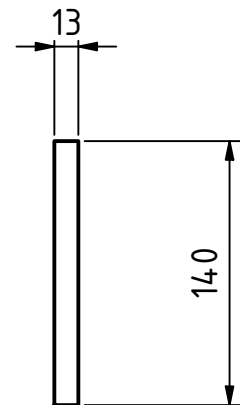
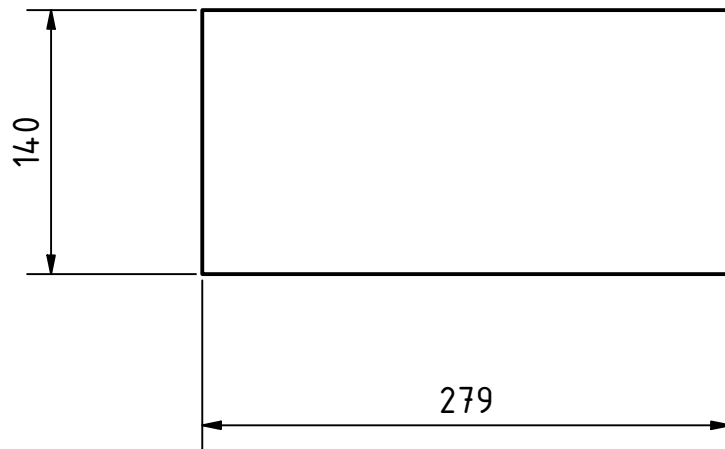

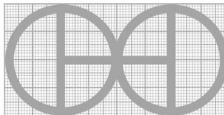
PROJECT		CREATED BY	APPROVED BY	DATE	VERSION
Nest box for rabbits		E. CEBALLOS	A. MORILLO	24-05-2021	1.0
PART NAME		FILE NAME			PART CODE
front table		front table.ipt			4
DEVELOPED BY	REDESIGNED BY	SUPPORTED BY	DOC. TYPE	MATERIAL	QUANTITY
			PART	Kiln-dried pine, thickness 1/2"	1
			LICENCE	SCALE	SHEET
Rodale Press	OHO e.V.		CC-BY-SA 4.0	1:4	7 / 8

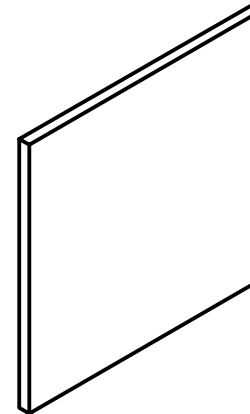
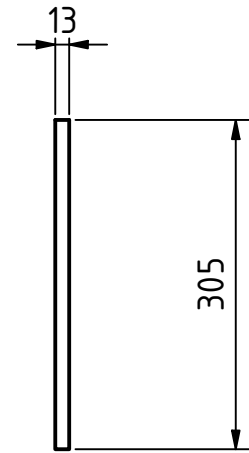
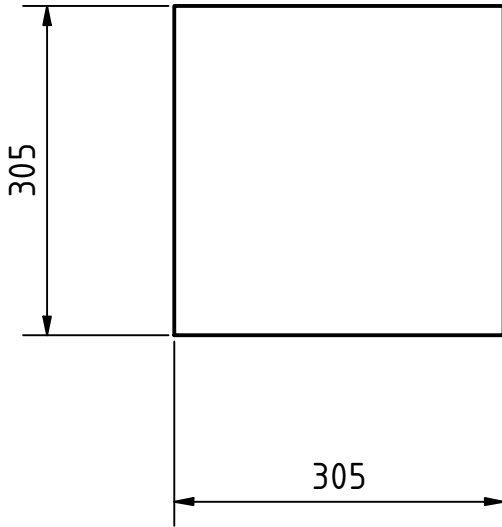

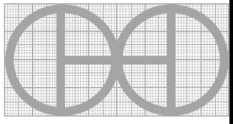
PROJECT		CREATED BY	APPROVED BY	DATE	VERSION
Nest box for rabbits		E. CEBALLOS	A. MORILLO	24-05-2021	1.0
PART NAME		FILE NAME			PART CODE
upper table		upper table.ipt			5
DEVELOPED BY	REDESIGNED BY	SUPPORTED BY	DOC. TYPE	MATERIAL	QUANTITY
			PART	Kiln-dried pine, thickness 1/2"	1
			LICENCE	SCALE	SHEET
Rodale Press	OHO e.V.		CC-BY-SA 4.0	1:7	8 / 8