

C-C ( 1 : 4 )

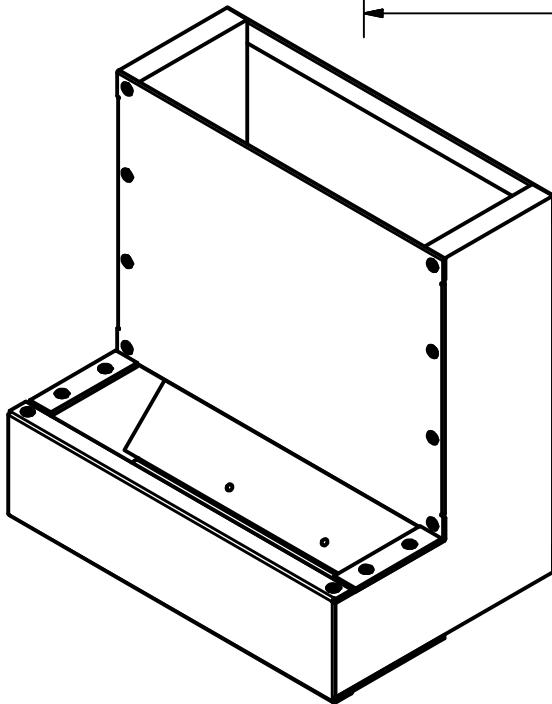

PROJECT		CREATED BY	APPROVED BY	DATE	VERSION
Feeder for Rabbits		D. Rodriguez	A. Morillo	27-05-2021	1.0
PART NAME		FILE NAME			PART CODE
Feeder for Rabbits		Feeder for Rabbits.iam			A1
DEVELOPED BY	REDESIGNED BY	SUPPORTED BY	DOC. TYPE	MATERIAL	QUANTITY
			ASSEMBLY		1
Rodale Press		OHO e.V.	LICENCE	SCALE	SHEET
			CC-BY-SA 4.0	1:4	1 / 10

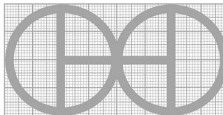
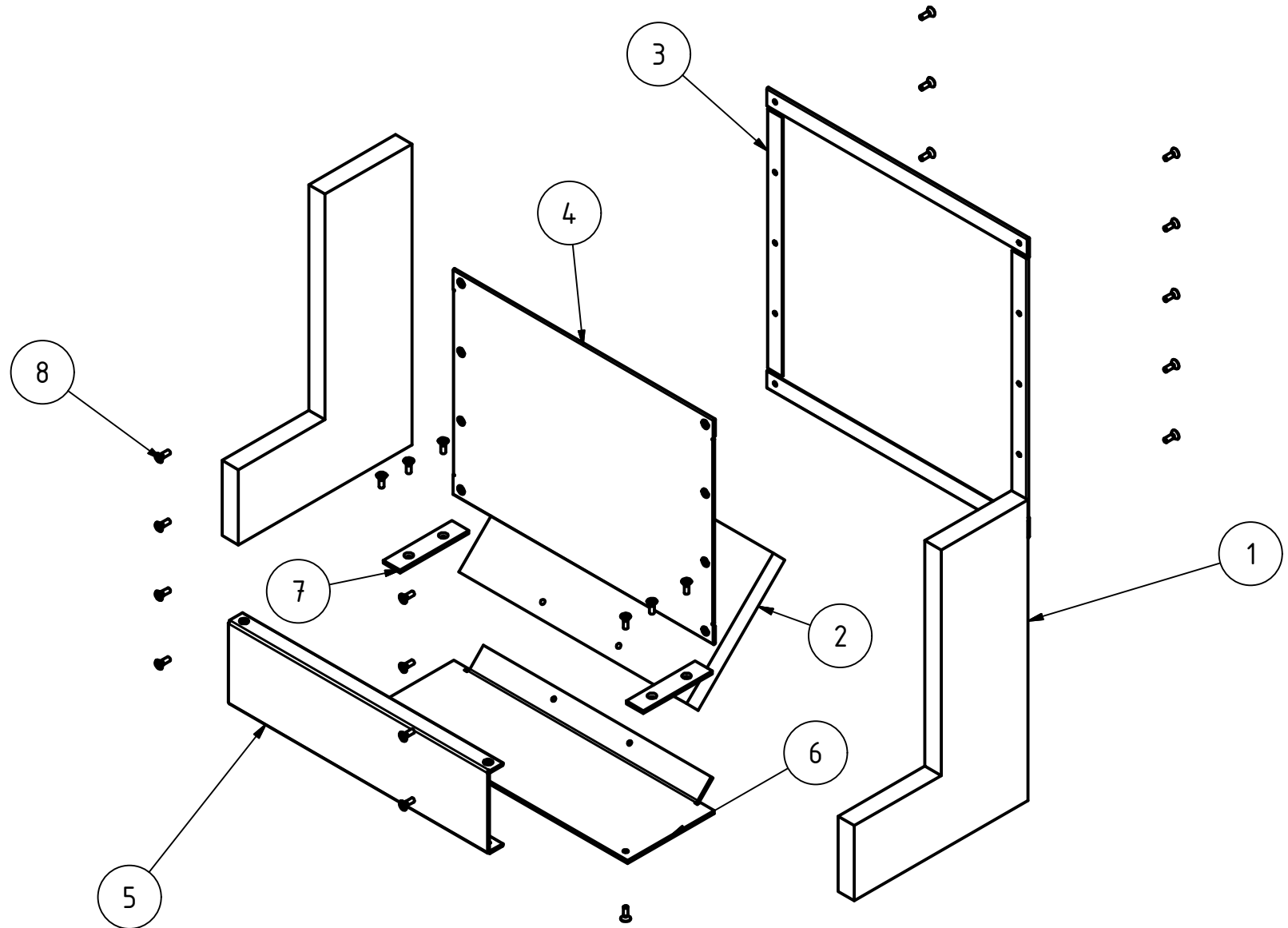
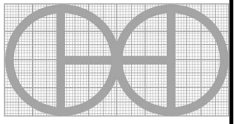

PROJECT		CREATED BY	APPROVED BY	DATE	VERSION
Feeder for Rabbits		D. Rodriguez	A. Morillo	27-05-2021	1.0
PART NAME		FILE NAME			PART CODE
Feeder for Rabbits		Feeder for Rabbits.ipn			A2
DEVELOPED BY	REDESIGNED BY	SUPPORTED BY	DOC. TYPE	MATERIAL	QUANTITY
			ASSEMBLY		1
Rodale Press	OHO e.V.		LICENCE	SCALE	SHEET
			CC-BY-SA 4.0	1:5	2 / 10

**PART LIST**

POS	POS.OLD	QTY	PART NAME	FILE NAME	PART TYPE	SPECIFICATIONS	SHEET
A1		1	Feeder for Rabbits	Feeder for Rabbits.iam			1
A2		1	Feeder for Rabbits	Feeder for Rabbits.ipn			2
B1			PART LIST				3
1		1	Wood Sheet1	Wood Sheet1.ipt	Production	Klin dried pine	4
2		1	Wood Sheet2	Wood Sheet2.ipt	Production	Klin dried pine	5
3		1	Metal Sheet1	Metal Sheet1.ipt	Production	thickness 1 mm, Steel C45	6
4		1	Metal Sheet2	Metal Sheet2.ipt	Production	thickness 1 mm, Steel C45	7
5		1	Metal Sheet3	Metal Sheet3.ipt	Production	thickness 1 mm, Steel C45	8
6		1	Metal Mesh	Metal Mesh.ipt	Production	Perforated Metal, Steel C45	9
7		2	Metal strip	EN 10278 - 20 x 3 - 80.5.ipt	Production	DIN 174 - 20 x 3 - 80.5, Steel A36	10
8		24	Drywall screw		Standard	#8 * 1/2"	

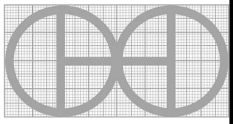
PROJECT		CREATED BY	APPROVED BY	DATE	VERSION
Feeder for Rabbits		D. Rodriguez	A. Morillo	27-05-2021	1.0
PART NAME		FILE NAME			PART CODE
PART LIST					B1
DEVELOPED BY	REDESIGNED BY	SUPPORTED BY	DOC. TYPE	MATERIAL	QUANTITY
			PART LIST		
Rodale Press	OH0 e.V.		LICENCE	SCALE	SHEET
			CC-BY-SA 4.0		3 /10

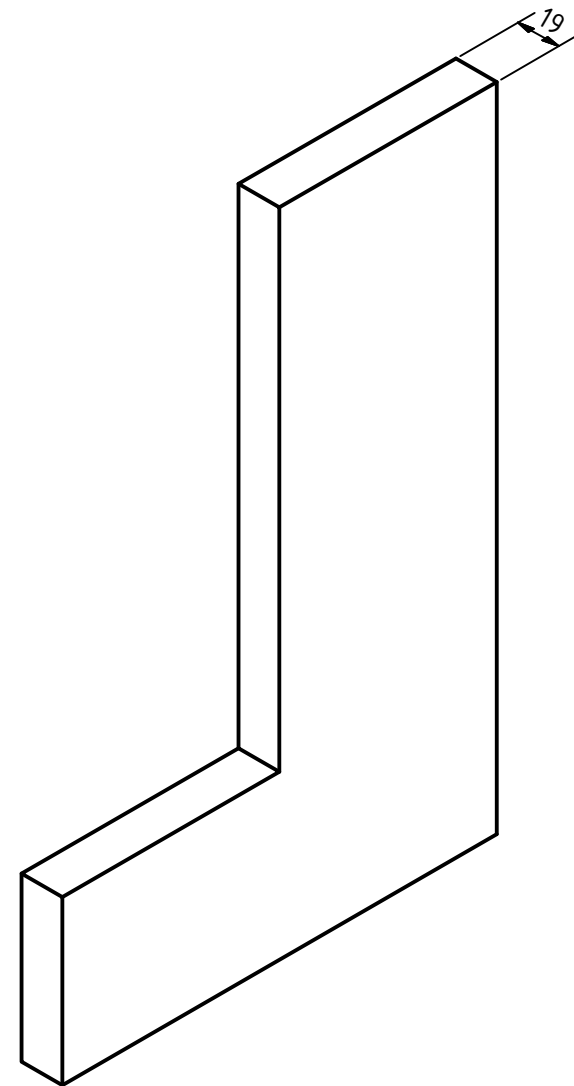
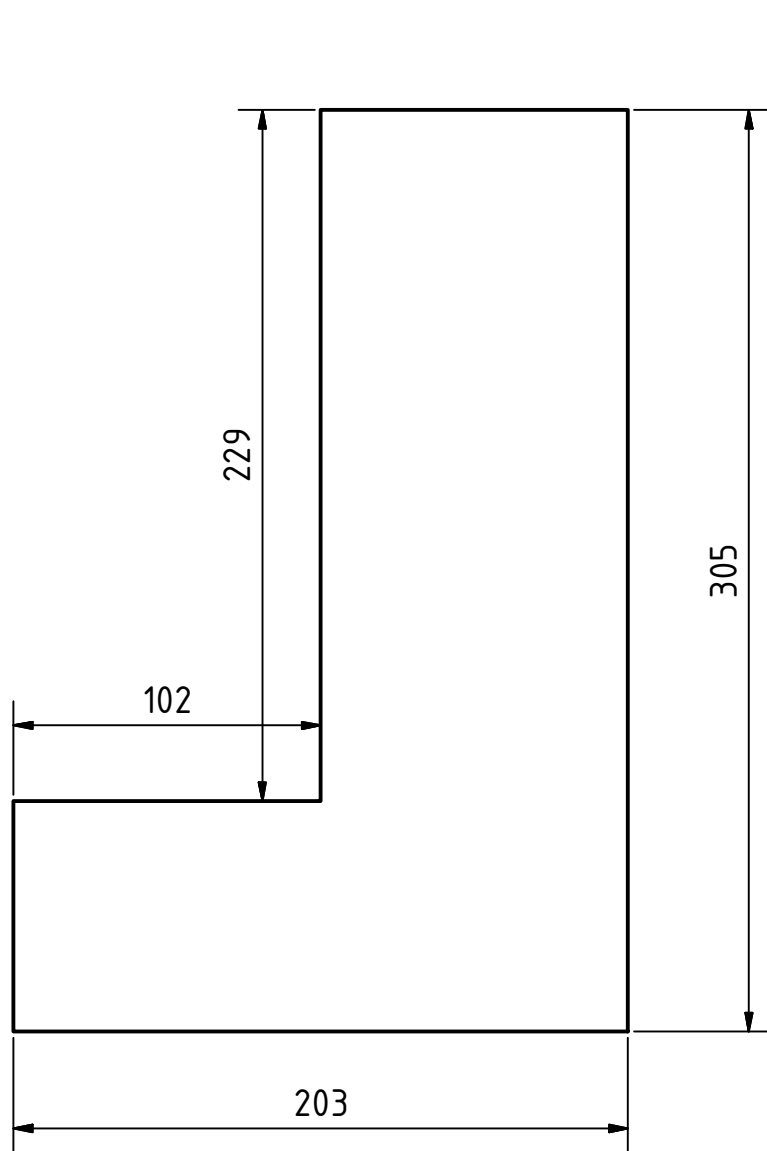

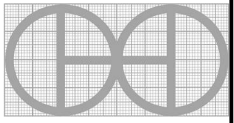
PROJECT		CREATED BY	APPROVED BY	DATE	VERSION
Feeder for Rabbits		D. Rodriguez	A. Morillo	27-05-2021	1.0
PART NAME		FILE NAME			PART CODE
Wood Sheet		Wood Sheet1.ipt			1
DEVELOPED BY	REDESIGNED BY	SUPPORTED BY	DOC. TYPE	MATERIAL	QUANTITY
			PART	Klin dried pine	1
			LICENCE	SCALE	SHEET
Rodale Press	OHO e.V.		CC-BY-SA 4.0		4 / 10

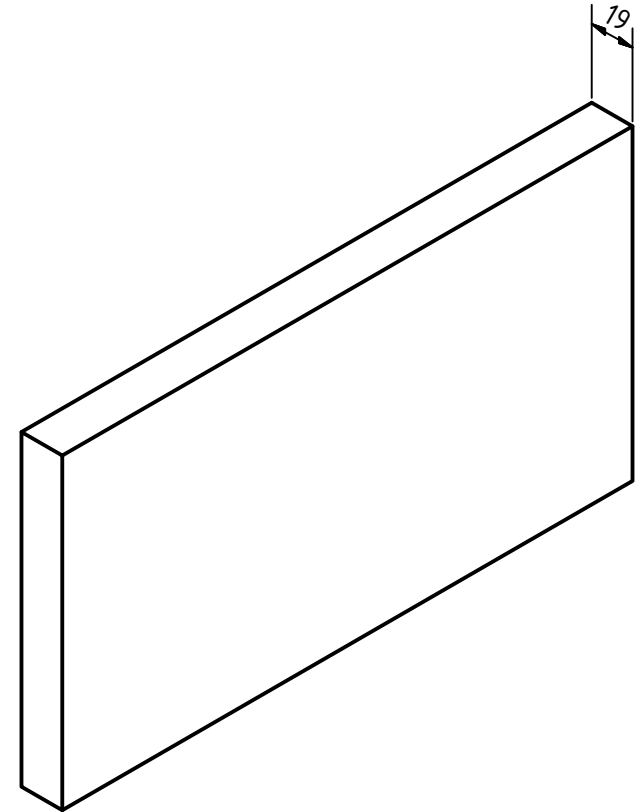
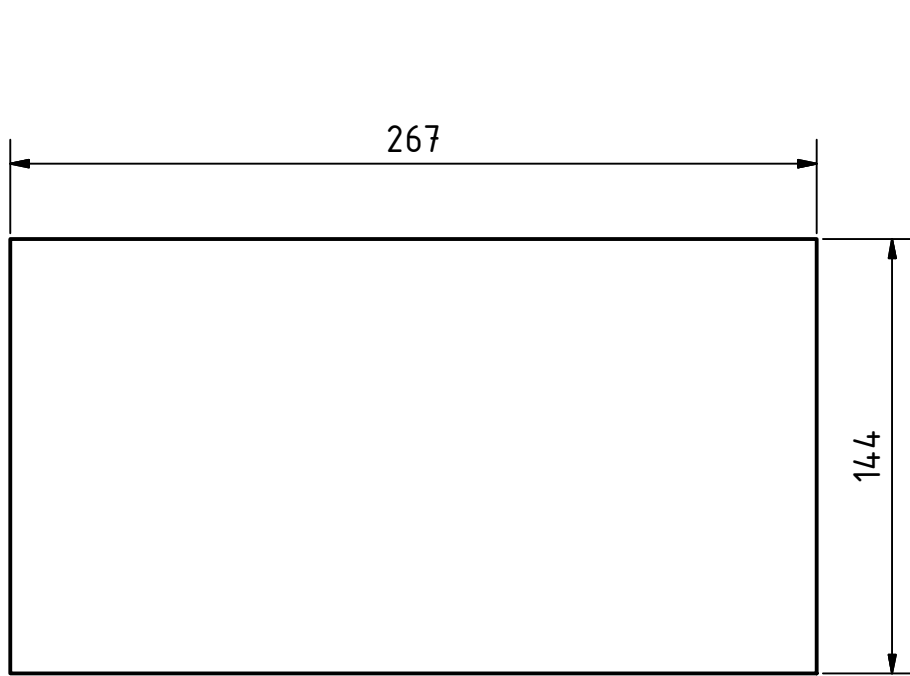

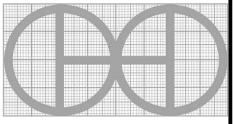
PROJECT		CREATED BY	APPROVED BY	DATE	VERSION
Feeder for Rabbits		D. Rodriguez	A. Morillo	27-05-2021	1.0
PART NAME		FILE NAME			PART CODE
Wood Sheet2		Wood Sheet2.ipt			2
DEVELOPED BY	REDESIGNED BY	SUPPORTED BY	DOC. TYPE	MATERIAL	QUANTITY
			PART	Klin dried pine	1
			LICENCE	SCALE	SHEET
Rodale Press	OHO e.V.		CC-BY-SA 4.0	1:2.5	5 /10

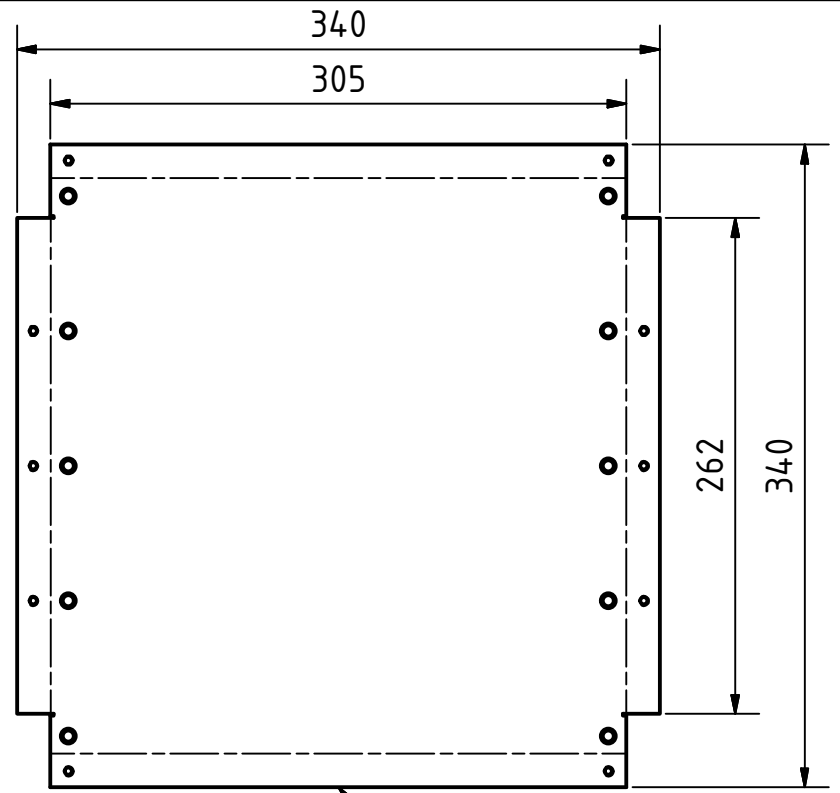
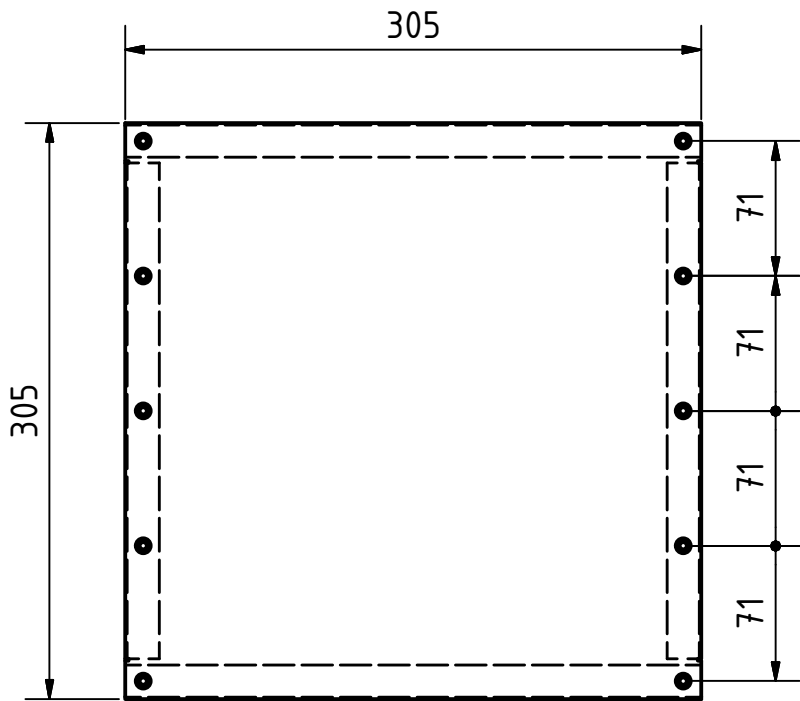

Thickness 1mm

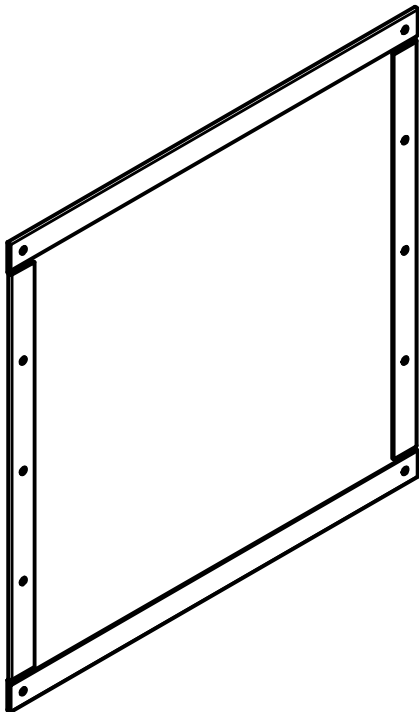

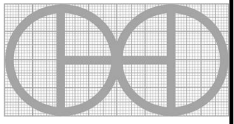
PROJECT		CREATED BY		APPROVED BY		DATE		VERSION	
Feeder for Rabbits		D. Rodriguez		A. Morillo		27-05-2021		1.0	
PART NAME				FILE NAME				PART CODE	
Metal Sheet1				Metal Sheet1.ipt				3	
DEVELOPED BY		REDESIGNED BY		SUPPORTED BY		DOC. TYPE	MATERIAL		QUANTITY
						PART	Steel C45		1
						LICENCE	SCALE		SHEET
Rodale Press		OHO e.V.				CC-BY-SA 4.0	1:4		6 /10

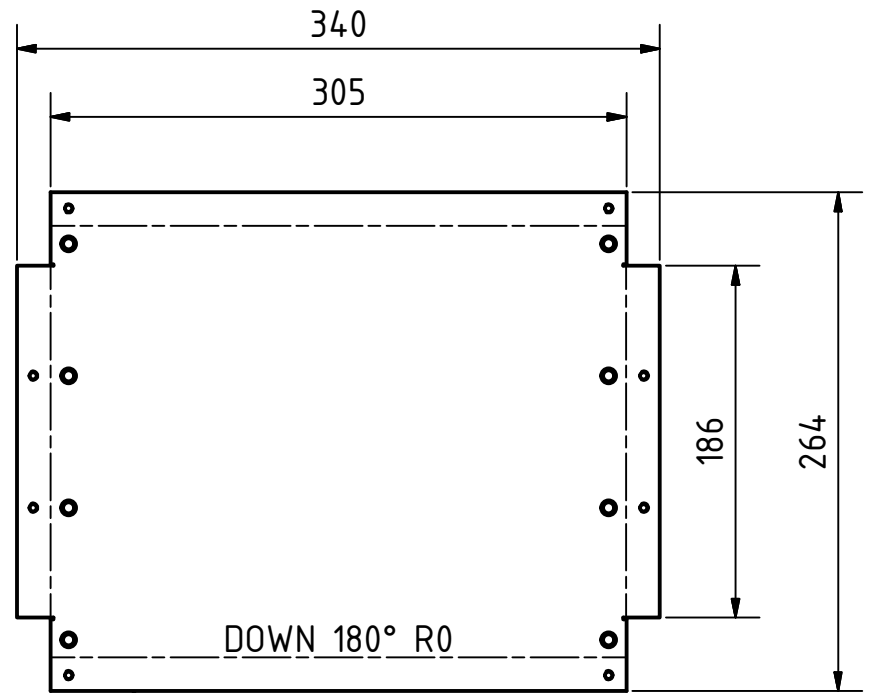
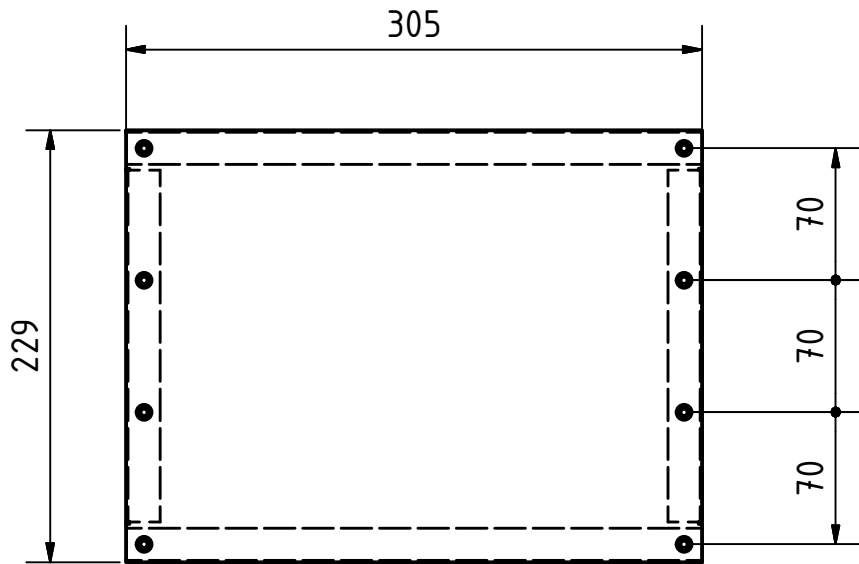

thickness 1 mm

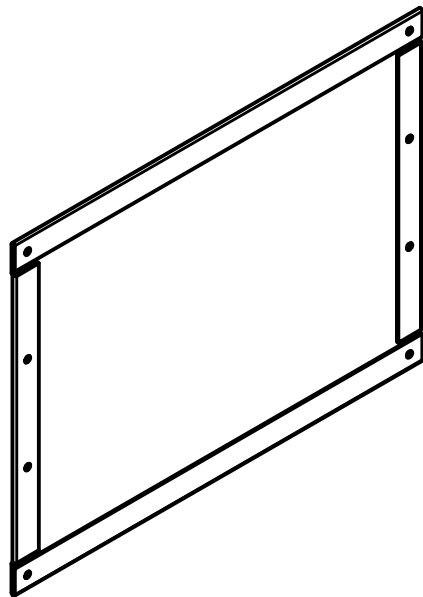

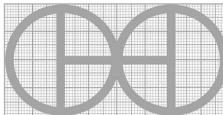
PROJECT		CREATED BY		APPROVED BY		DATE		VERSION	
Feeder for Rabbits		D. Rodriguez		A. Morillo		27-05-2021		1.0	
PART NAME				FILE NAME				PART CODE	
Metal Sheet2				Metal Sheet2.ipt				4	
DEVELOPED BY		REDESIGNED BY		SUPPORTED BY		DOC. TYPE	MATERIAL		QUANTITY
						PART	Steel C45		1
						LICENCE	SCALE		SHEET
Rodale Press		OHO e.V.				CC-BY-SA 4.0	1:4		7 /10

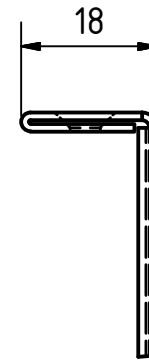
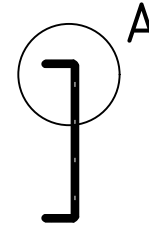
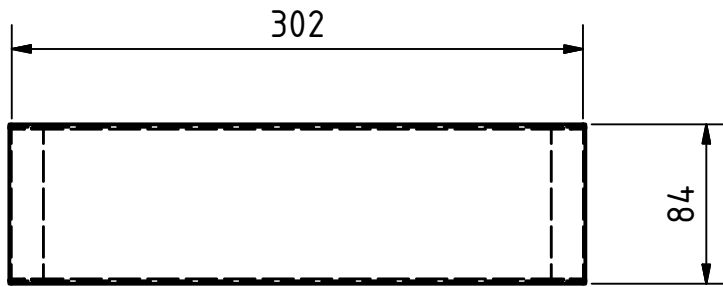

A ( 1 : 1 )

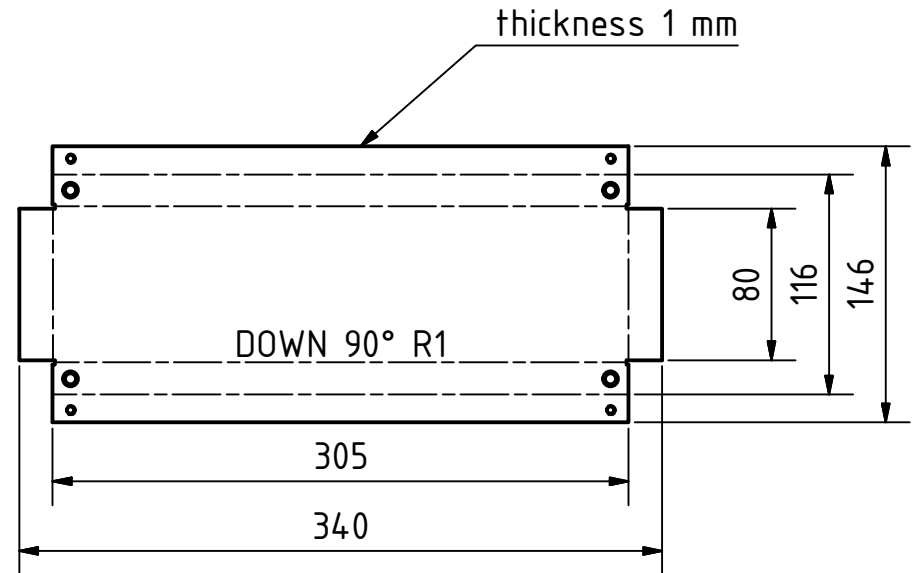
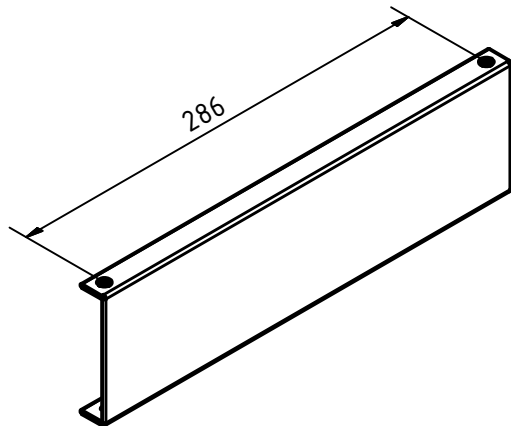

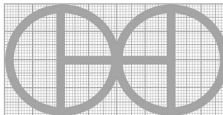
PROJECT		CREATED BY	APPROVED BY	DATE	VERSION
Feeder for Rabbits		D. Rodriguez	A. Morillo	27-05-2021	1.0
PART NAME		FILE NAME			PART CODE
Metal Sheet3		Metal Sheet3.ipt			5
DEVELOPED BY	REDESIGNED BY	SUPPORTED BY	DOC. TYPE	MATERIAL	QUANTITY
			PART	Steel C45	1
Rodale Press	OHO e.V.		LICENCE	SCALE	SHEET
			CC-BY-SA 4.0	1:4	8 /10



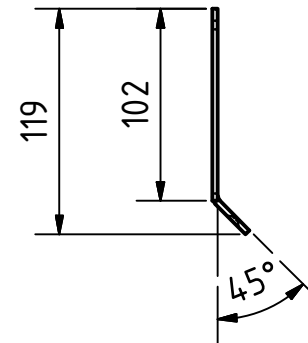
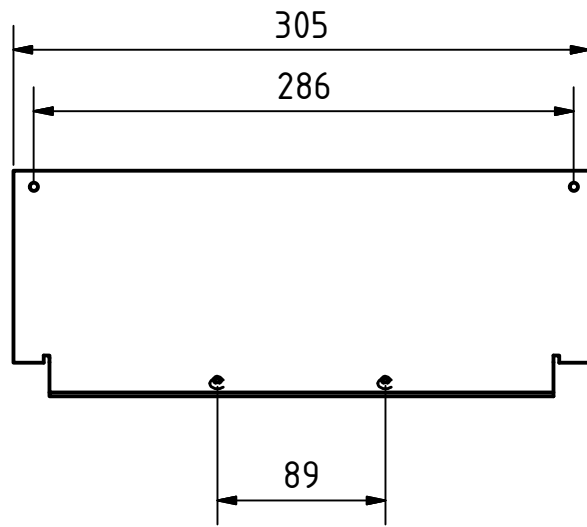

thickness 3mm  
Perforated metal

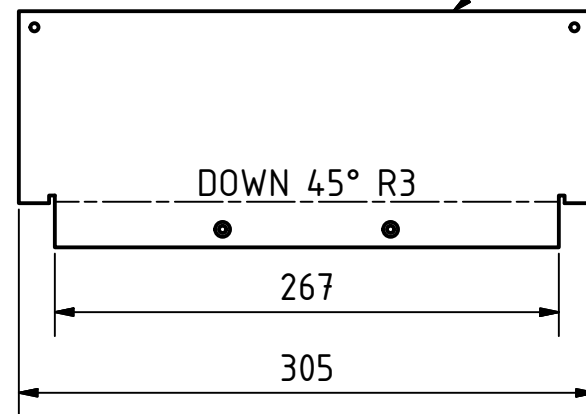
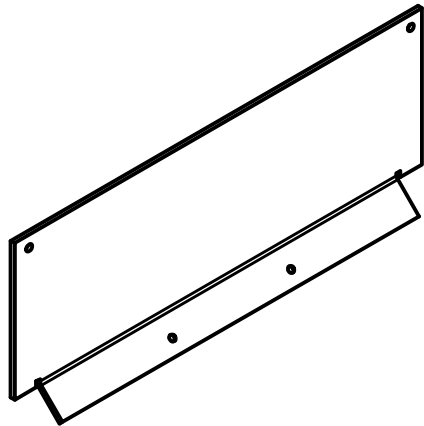

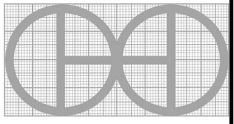
PROJECT		CREATED BY		APPROVED BY		DATE		VERSION	
Feeder for Rabbits		D. Rodriguez		A. Morillo		27-05-2021		1.0	
PART NAME		FILE NAME						PART CODE	
Metal Mesh		Metal Mesh.ipt						6	
DEVELOPED BY		REDESIGNED BY		SUPPORTED BY		DOC. TYPE	MATERIAL		QUANTITY
						PART	Steel C45		1
Rodale Press		OHO e.V.				LICENCE	SCALE		SHEET
						CC-BY-SA 4.0	1:4		9 / 10

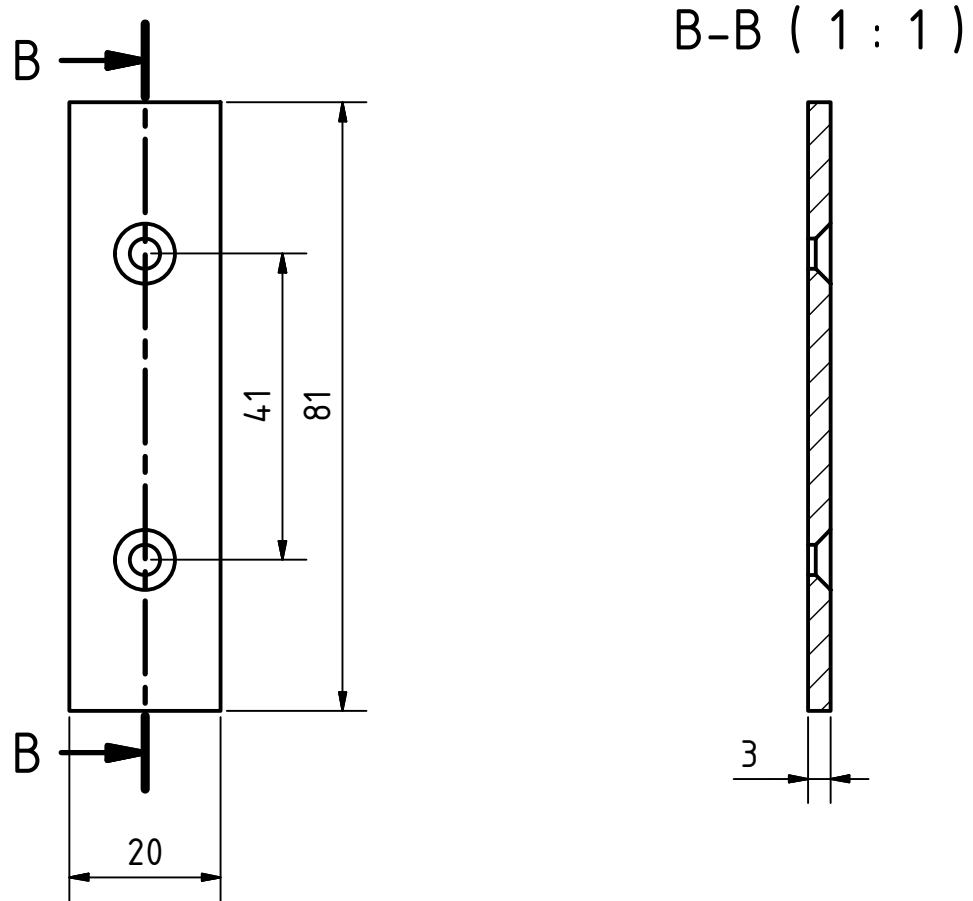

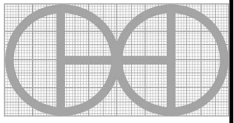
PROJECT		CREATED BY	APPROVED BY	DATE	VERSION
Feeder for Rabbits		D. Rodriguez	A. Morillo	27-05-2021	1.0
PART NAME		FILE NAME			PART CODE
Metal strip		EN 10278 - 20 x 3 - 80.5.ipt			7
DEVELOPED BY	REDESIGNED BY	SUPPORTED BY	DOC. TYPE	MATERIAL	QUANTITY
			PART	Steel A36	2
			LICENCE	SCALE	SHEET
Rodale Press	OHO e.V.		CC-BY-SA 4.0	1:1	10 /10