

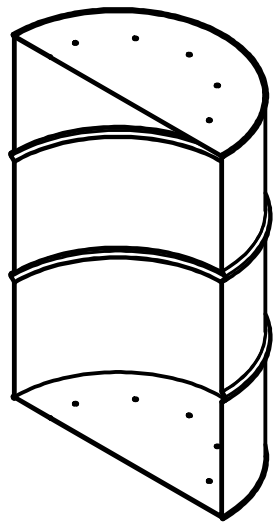

2

1

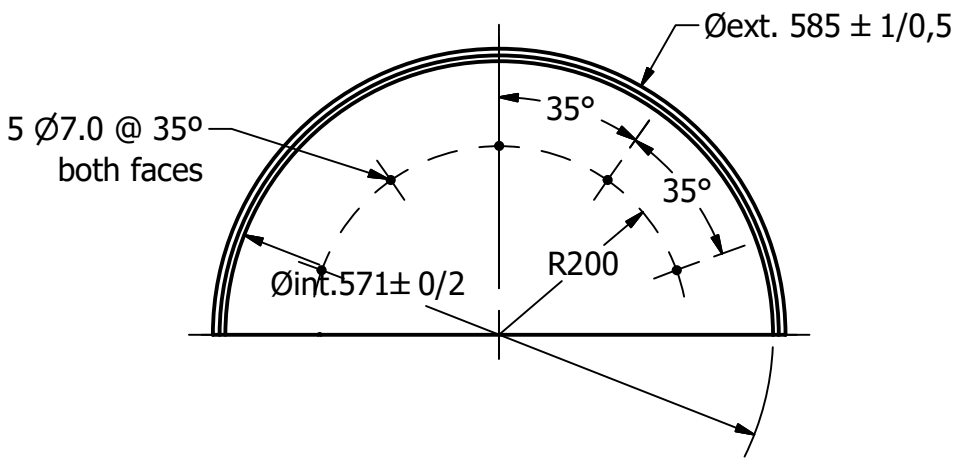
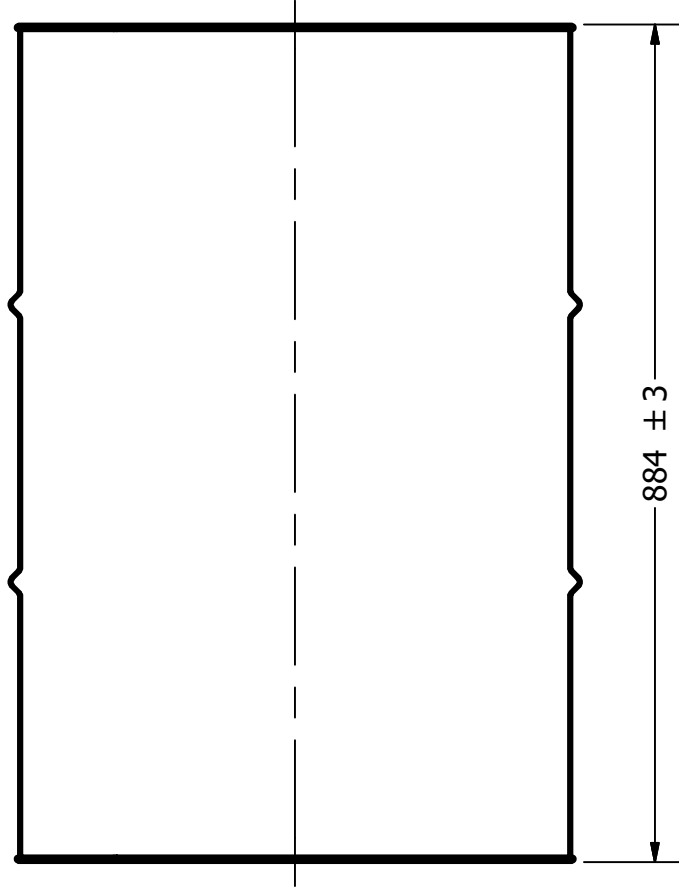

Proyect Wind Mill Pump		Created by D. Mosquera		Approved by D. Jaeger	
Part Name 1/2 Oil drum		Part Code 1.1		Document Type part	
Material Roller Steel		Version 1.0		Quantity 9	
Redesigned by  OPEN SOURCE ECOLOGY GERMANY		Supported by  E.ON STIFTUNG		File Name oseg_wmp_1-2-oil-drum.ipt	
License CC BY-SA 4.0		Scale 1 / 8		Date 28.02.21	

2

1

