

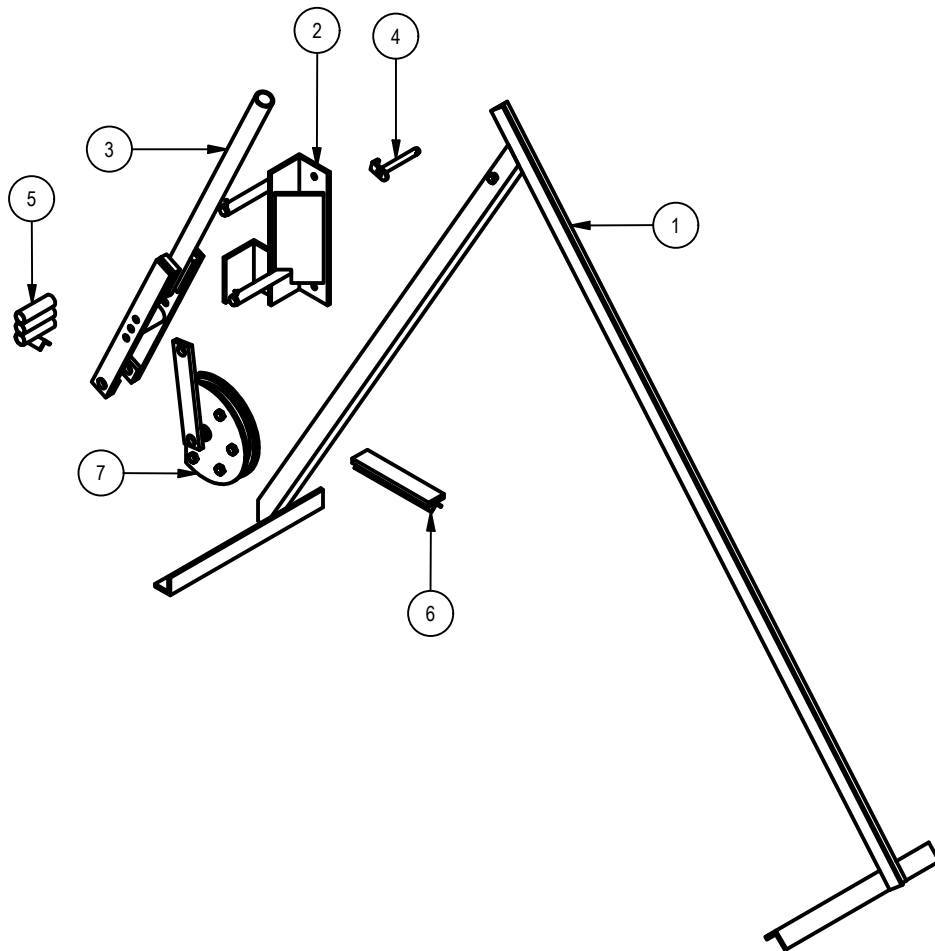

PROJECT PIPE BENDING MACHINE		CREATED BY A. PARDO		APPROVED BY D. Jaeger	
PART NAME PIPE BENDING MACHINE		PART CODE A1		DOCUMENT TYPE ASSEMBLY	
 Open Source Ecology e.V. Knobelsdorffstr. 22 14059 Berlin www.ose-germany.de +49 (0) 30 / 92282426		LICENSE CERN-OHL		FILE NAME PIPE BENDING MACHINE.iam	
		SCALE 1 / 16		VERSION 1.0	
				SHEET 1	
				DATE 28/11/2020	



PROJECT PIPE BENDING MACHINE		CREATED BY A. PARDO		APPROVED BY D. Jaeger	
PART NAME PIPE BENDING MACHINE		PART CODE A2		DOCUMENT TYPE ASSEMBLY	
 Open Source Ecology e.V. Knobelsdorffstr. 22 14059 Berlin www.ose-germany.de +49 (0) 30 / 92282426		LICENSE CERN-OHL		FILE NAME PIPE BENDING MACHINE.iam	
		SCALE 1 / 14		VERSION 1.0	
				SHEET 2	
				DATE 28/11/2020	

PARTS LIST							
POS.	POS. OLD	QTY	PART NAME	FILE NAME	PART TYPE	SPECIFICATION	SHEET
A1		1	PIPE BENDING MACHINE	PIPE BENDING MACHINE.iam			1
A2		1	PIPE BENDING MACHINE	PIPE BENDING MACHINE.iam			2
B1		1	PARTS LITS	PARTS LITS PIPEBENDING MACHINE.iam			3
1		1	SUB-PIPE BENDING MACHINE 1	SUB-PIPE BENDING MACHINE 1.iam			4
1.1	1	1	FRAME	FRAME.ipt	Production	FRAME	5
1.2	4	1	MAIN PIN	MAIN PIN.ipt	Production	MAIN PIN	6
1.3	2	1	STIFFENER	STIFFENER.ipt	Production	STIFFENER	7
1.4	3	1	FORMER STOP	FORMER STOP.ipt	Production	FORMER STOP	8
1.5		2	Pin - Cotter		Standard	SAE J487a - 3/32 x 1 Extended Prong Square Cut Type	
2		1	SUB-PIPE BENDING MACHINE 2	SUB-PIPE BENDING MACHINE 2.iam			9
2.1	9	1	FOOT	FOOT.ipt	Production	FOOT	10
2.2	6	1	SUPPORT LEG	SUPPORT LEG.ipt	Production	SUPPORT LEG	11
2.3	5	1	MAIN LEG	MAIN LEG.ipt	Production	MAIN LEG	12
2.4		1	Metric Formed Hex Screw		Standard	ANSI B18.2.3.2M - M10 x 1.5	
2.5		6	Hex Jam Nut		Standard	ANSI B18.2.4.5M - M10 x 1.5	
3		1	SUB-PIPE BENDING MACHINE 3	SUB-PIPE BENDING MACHINE 3.iam			13
3.1	18	1	HANDLE	HANDLE.ipt	Production	HANDLE	14
3.2	21	1	FORMER SPACER	FORMER SPACER.ipt	Production	FORMER SPACER	15
3.3	19	1	HANDLE ARM	HANDLE ARM.ipt	Production	HANDLE ARM	16
3.4	20	1	HANDLE SPACER	HANDLE SPACER.ipt	Production	HANDLE SPACER	17
3.5	17	1	ROLLER	ROLLER.ipt	Production	ROLLER	18
4		1	SUB-PIPE BENDING MACHINE 4	SUB-PIPE BENDING MACHINE 4.iam			19
4.1	14	1	ROLLER PIN	ROLLER PIN.ipt	Production	ROLLER PIN	20
4.2	15	1	PIN HANDLE	PIN HANDLE.ipt	Production	PIN HANDLE	21
5		1	SUB-PIPE BENDING MACHINE 5	SUB-PIPE BENDING MACHINE 5.iam			22
5.1	10	1	STOP TUBE	STOP TUBE.ipt	Production	STOP TUBE	23
5.2	11	1	STOP ANGLE	STOP ANGLE.ipt	Production	STOP ANGLE	24
6		1	SUB-PIPE BENDING MACHINE 6	SUB-PIPE BENDING MACHINE 6.iam			25
6.1	12	1	GUIDE ANGLE	GUIDE ANGLE.ipt	Production	GUIDE ANGLE	26
6.2	13	1	GUIDE BASE	GUIDE BASE.ipt	Production	GUIDE BASE	27
7		1	SUB-PIPE BENDING MACHINE 7	SUB-PIPE BENDING MACHINE 7.iam			28
7.1	23	1	FORMER BASE	FORMER BASE.ipt	Production	FORMER SIDE	29
7.2	24	1	FORMER SIDE	FORMER SIDE.ipt	Production	FORMER SIDE	30
7.3	25	1	SPACER TUBE	SPACER TUBE.ipt	Production	SPACER TUBE	31
7.4	22	1	PIN LINK	PIN LINK.ipt	Production	PIN LINK	32
7.5		5	Hex Bolt		Standard	ANSI B18.2.3.5M - M10 x 1,5 x 45	

PROJECT PIPE BENDING MCHINE		CREATED BY A. PARDO	APPROVED BY D. Jaeger	
PART NAME PIPE BENDING MACHINE		PART CODE B1	DOCUMENT TYPE PART LIST	MATERIAL
 Open Source Ecology e.V. Knobelsdorffstr. 22 14059 Berlin www.ose-germany.de +49 (0) 30 / 92282426		LICENSE CERN-OHL	FILE NAME parts list pipe binding machine.iam	VERSION 1.0
			SCALE 1 / 20	QUANTITY 3
			SHEET 3	DATE 29/10/2020

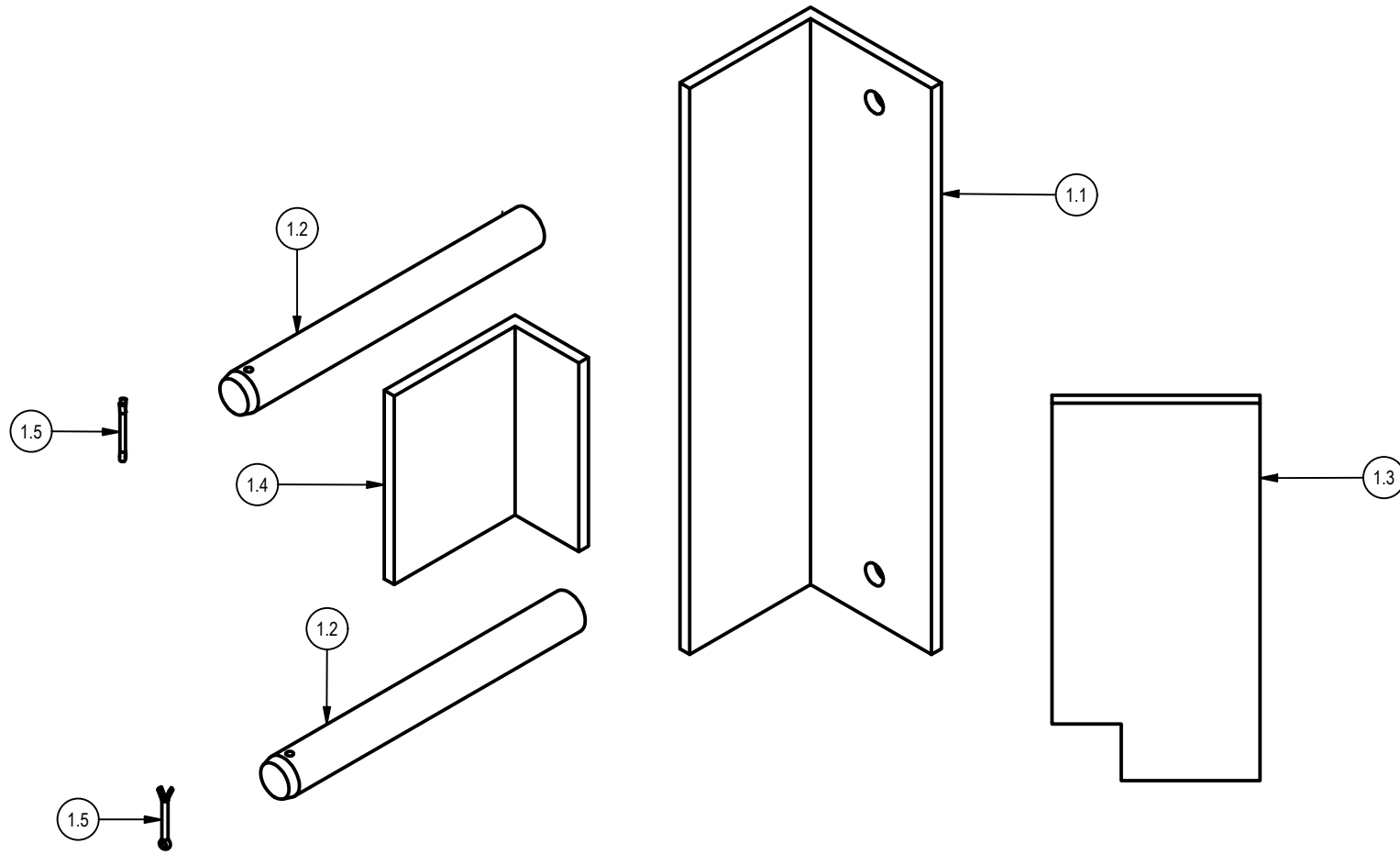

PROJECT PIPE BENDING MACHINE		CREATED BY A. PARDO		APPROVED BY D. Jaeger	
PART NAME SUB-PIPE BENDING MACHINE 1		PART CODE 1		DOCUMENT TYPE ASSEMBLY	
 Open Source Ecology e.V. Knobelsdorffstr. 22 14059 Berlin www.ose-germany.de +49 (0) 30 / 92282426		LICENSE CERN-OHL		FILE NAME SUB-PIPE BENDING MACHINE 1.iam	
		SCALE 1 / 3		VERSION 1.0	
		SHEET 1		DATE 26/11/2020	

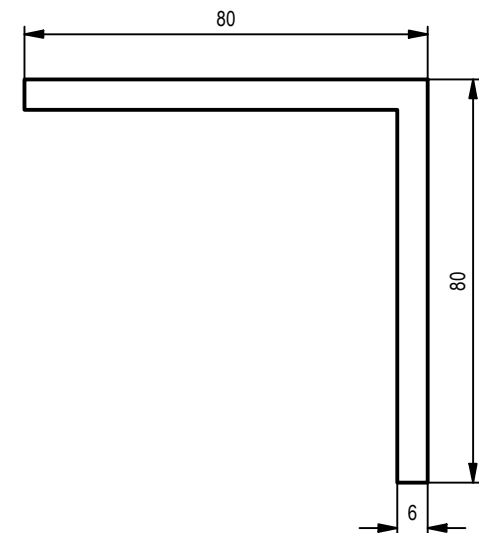
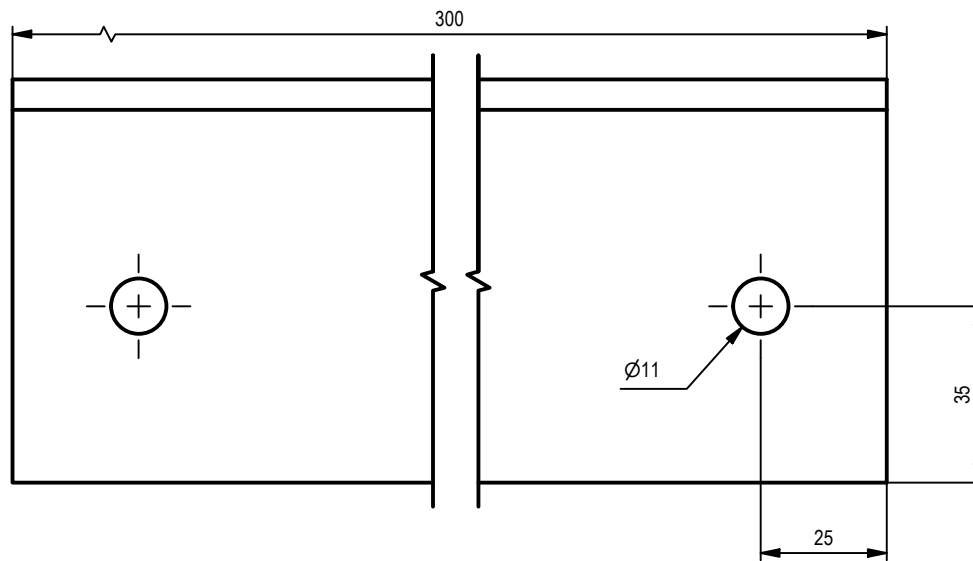
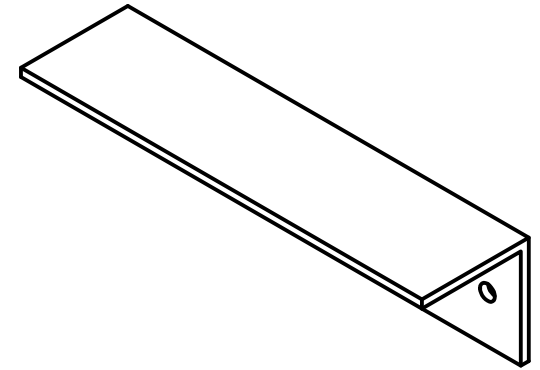

PROJECT PIPE BENDING MACHINE		CREATED BY A. PARDO		APPROVED BY D. Jaeger	
PART NAME FRAME		PART CODE 1.1		DOCUMENT TYPE Production	
 Open Source Ecology e.V. Knobelsdorffstr. 22 14059 Berlin www.ose-germany.de +49 (0) 30 / 92282426		LICENSE CERN-OHL		FILE NAME FRAME.ipt	
		SCALE 1 : 1.5		MATERIAL Steel C45	
		VERSION 1.0		QUANTITY 1	
		SHEET 5		DATE 26/10/2020	

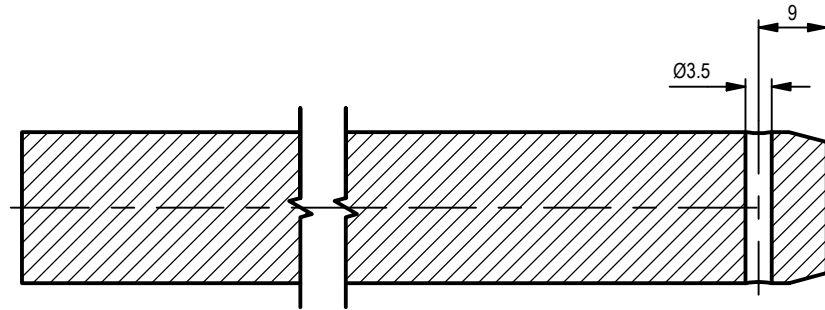
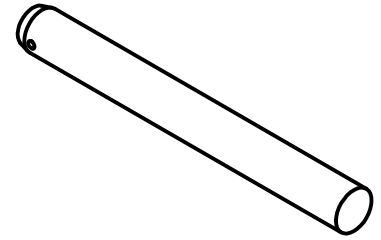

SECTION B-B
SCALE 1 : 1

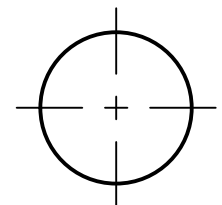
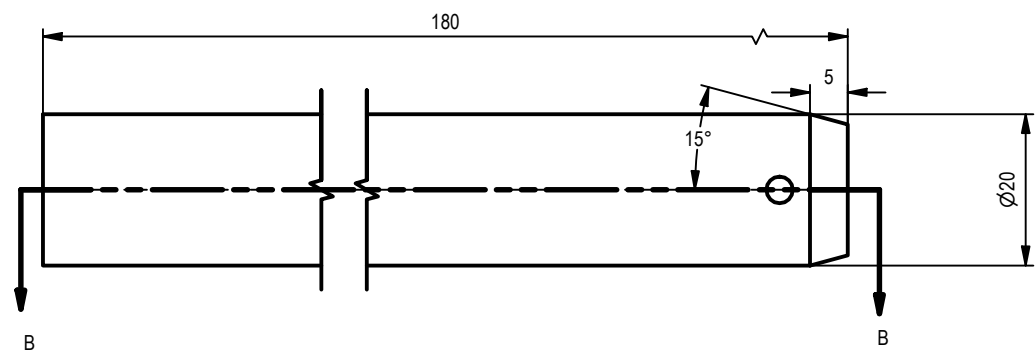

PROJECT PIPE BENDING MACHINE		CREATED BY A. PARDO		APPROVED BY D. Jaeger	
PART NAME MAIN PIN		PART CODE 1.2		DOCUMENT TYPE Production	
 Open Source Ecology e.V. Knobelsdorffstr. 22 14059 Berlin www.ose-germany.de +49 (0) 30 / 92282426		LICENSE CERN-OHL		MATERIAL Steel C45	
		FILE NAME MAIN PIN.ipt		VERSION 1.0	
		SCALE 1 : 1		SHEET 6	
				DATE 26/10/2020	

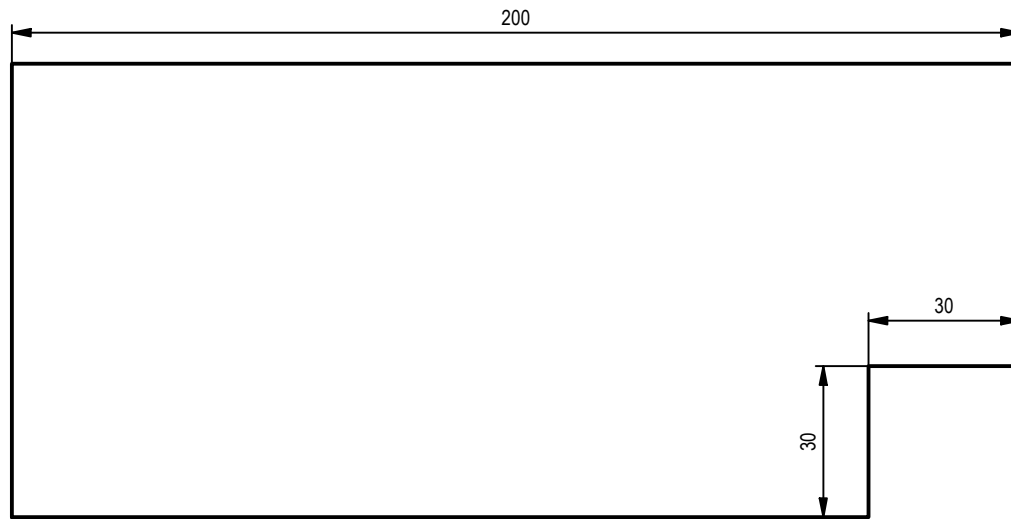
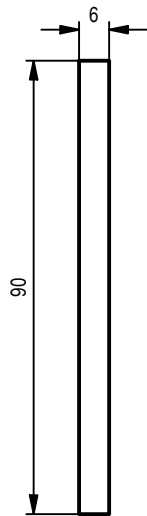
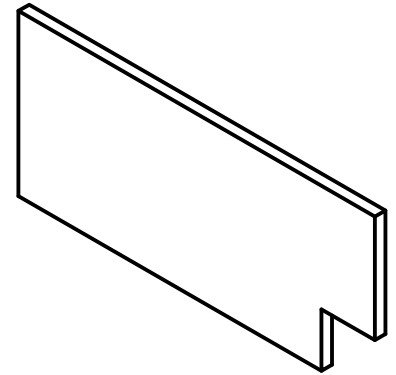

PROJECT PIPE BENDING MACHINE		CREATED BY A. PARDO	APPROVED BY D. Jaeger		
PART NAME STIFFENER		PART CODE 1.3	DOCUMENT TYPE Production	MATERIAL Steel C45	
 Open Source Ecology e.V. Knobelsdorffstr. 22 14059 Berlin www.ose-germany.de +49 (0) 30 / 92282426		LICENSE CERN-OHL	FILE NAME STIFFENER.ipt	VERSION 1.0	QUANTITY 1
			SCALE 1 : 1.5	SHEET 7	DATE 26/10/2020

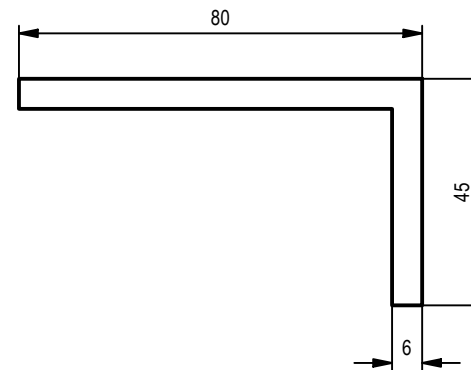
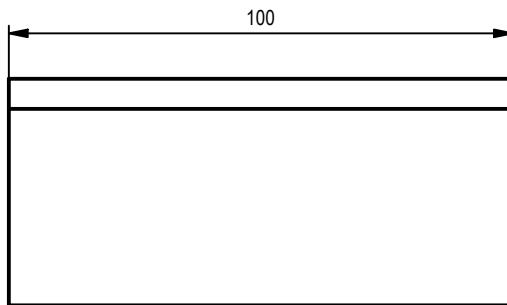
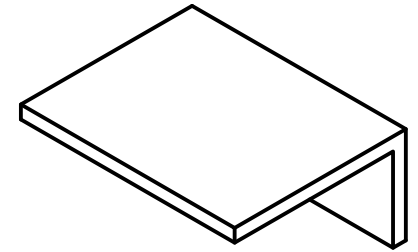

PROJECT PIPE BENDING MACHINE		CREATED BY A. PARDO		APPROVED BY D. Jaeger		
PART NAME FORMER STOP		PART CODE 1.4	DOCUMENT TYPE Production		MATERIAL Steel C45	
 Open Source Ecology e.V. Knobelsdorffstr. 22 14059 Berlin www.ose-germany.de +49 (0) 30 / 92282426		LICENSE CERN-OHL	FILE NAME FORMER STOP.ipt		VERSION 1.0	QUANTITY 1
			SCALE 1 : 1.5	SHEET 8	DATE 26/10/2020	

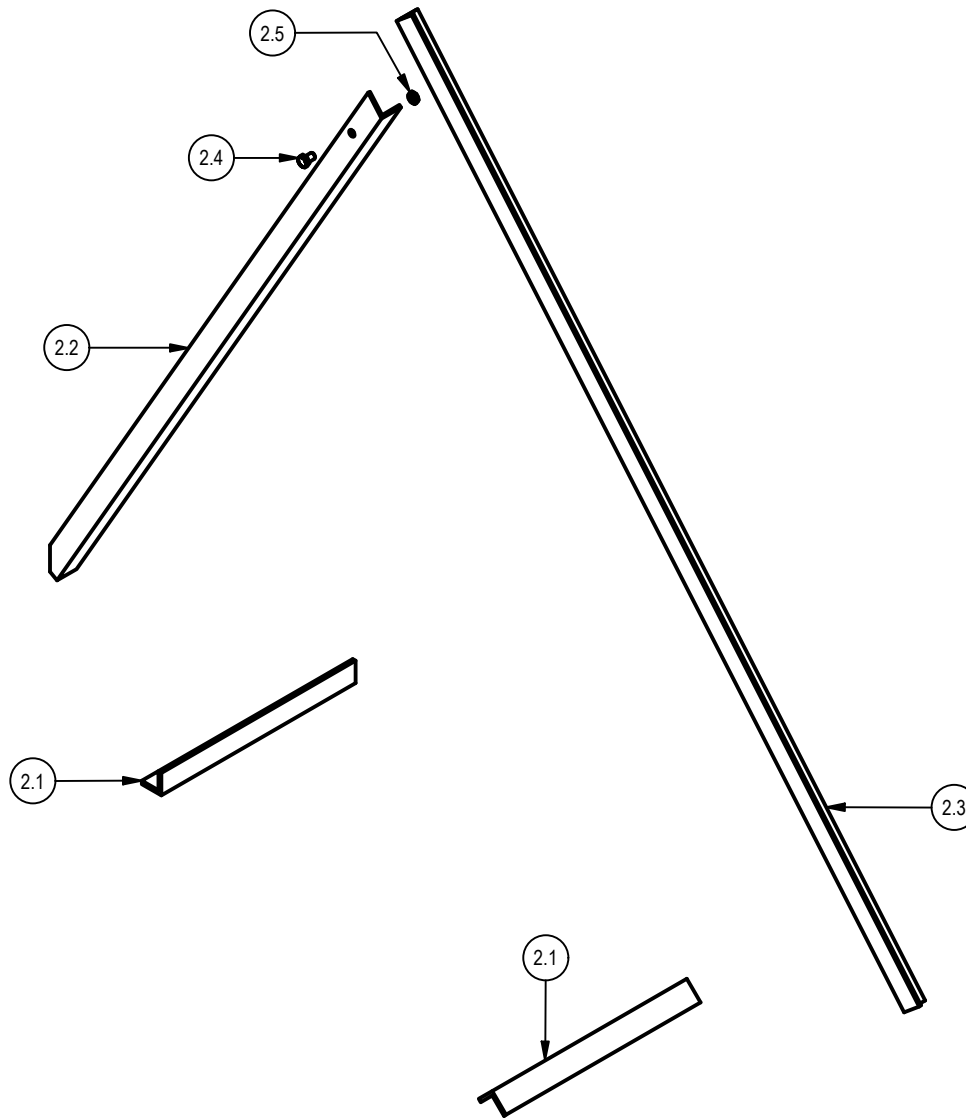

PROJECT PIPE BENDING MACHINE		CREATED BY A. PARDO		APPROVED BY D. Jaeger	
PART NAME SUB-PIPE BENDING MACHINE 2		PART CODE 2		DOCUMENT TYPE ASSEMBLY	
 Open Source Ecology e.V. Knobelsdorffstr. 22 14059 Berlin www.ose-germany.de +49 (0) 30 / 92282426		LICENSE CERN-OHL		FILE NAME SUB-PIPE BENDING MACHINE 2.iam	
		SCALE 1 / 11		VERSION 1.0	
				SHEET 9	
				DATE 26/11/2020	

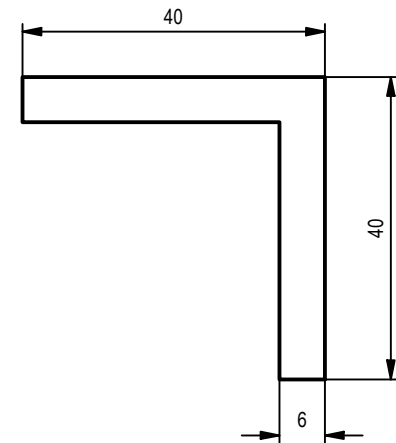
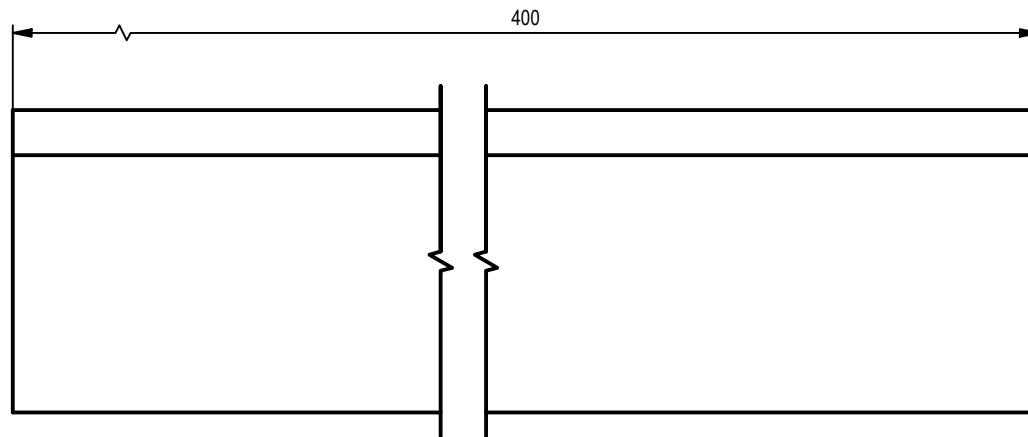
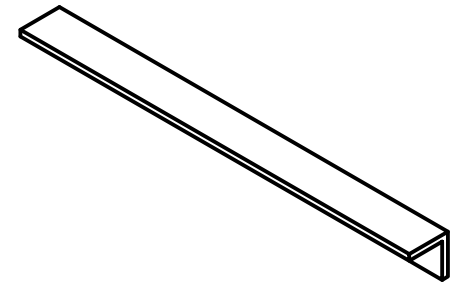

PROJECT PIPE BENDING MACHINE		CREATED BY A. PARDO		APPROVED BY D. Jaeger	
PART NAME FOOT		PART CODE 2.1		DOCUMENT TYPE Production	
 Open Source Ecology e.V. Knobelsdorffstr. 22 14059 Berlin www.ose-germany.de +49 (0) 30 / 92282426		LICENSE CERN-OHL		FILE NAME FOOT.ipt	
		SCALE 1 : 1		MATERIAL Steel C45	
		VERSION 1.0		QUANTITY 1	
		SHEET 10		DATE 26/10/2020	

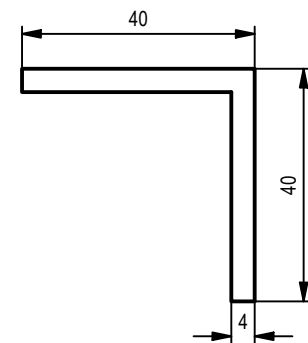
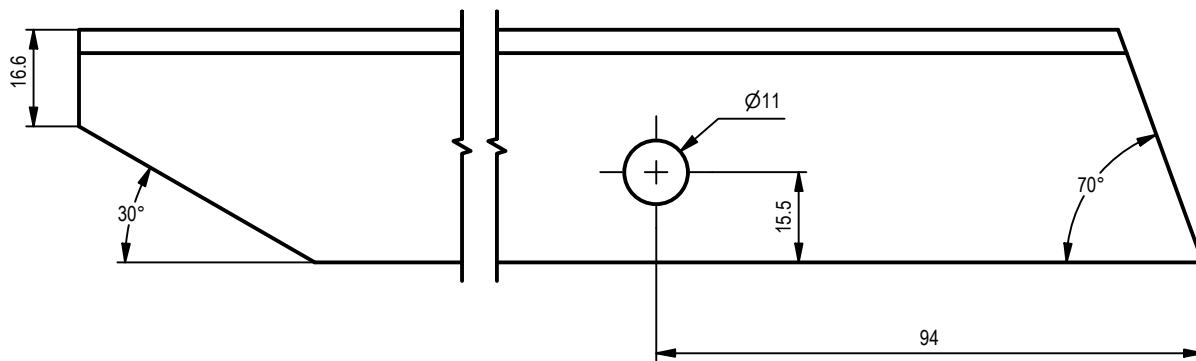
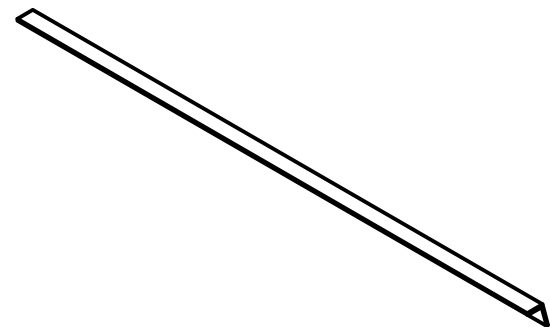

PROJECT PIPE BENDING MACHINE		CREATED BY A. PARDO		APPROVED BY D. Jaeger	
PART NAME SUPPORT LEG		PART CODE 2.2		DOCUMENT TYPE Production	
 Open Source Ecology e.V. Knobelsdorffstr. 22 14059 Berlin www.ose-germany.de +49 (0) 30 / 92282426		LICENSE CERN-OHL		MATERIAL Steel C45	
		FILE NAME SUPPORT LEG.ipt		VERSION 1.0	
		SCALE 1 : 1.3		SHEET 11	
				DATE 26/10/2020	

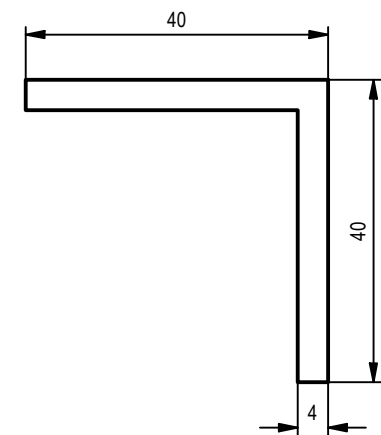
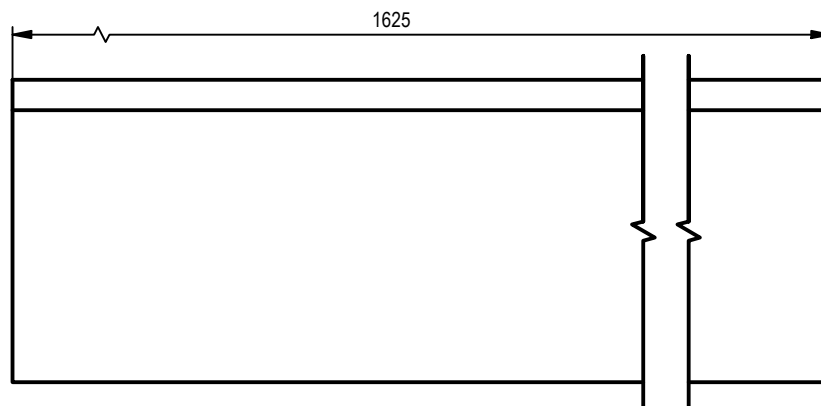
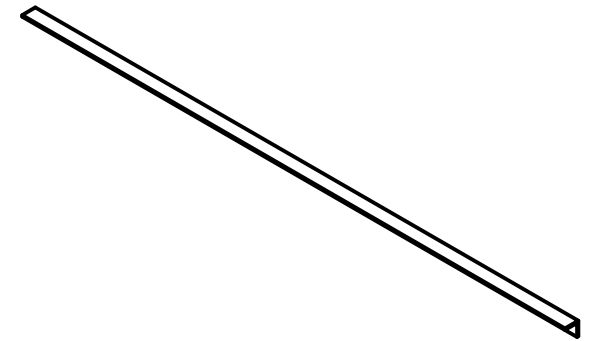

PROJECT PIPE BENDING MACHINE		CREATED BY A. PARDO		APPROVED BY D. Jaeger		
PART NAME MAIN LEG		PART CODE 2.3	DOCUMENT TYPE Production		MATERIAL Steel C45	
 Open Source Ecology e.V. Knobelsdorffstr. 22 14059 Berlin www.ose-germany.de +49 (0) 30 / 92282426		LICENSE CERN-OHL	FILE NAME MAIN LEG.ipt		VERSION 1.0	QUANTITY 1
			SCALE 1 : 1	SHEET 12	DATE 26/10/2020	

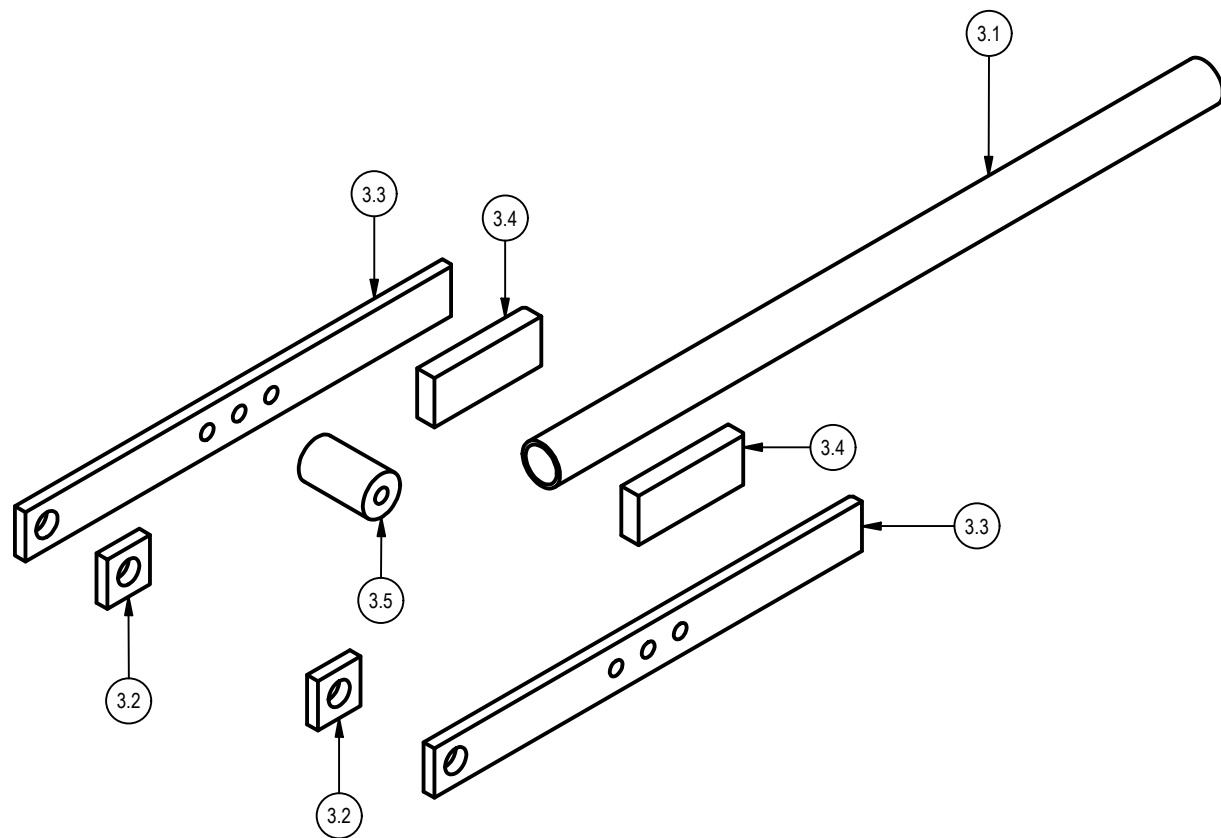

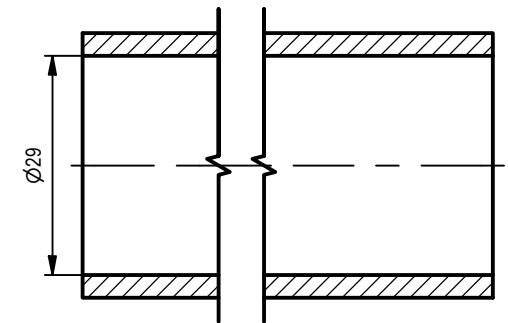
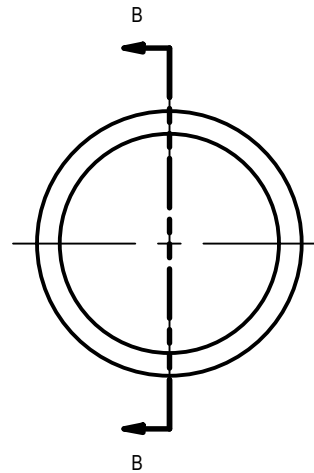
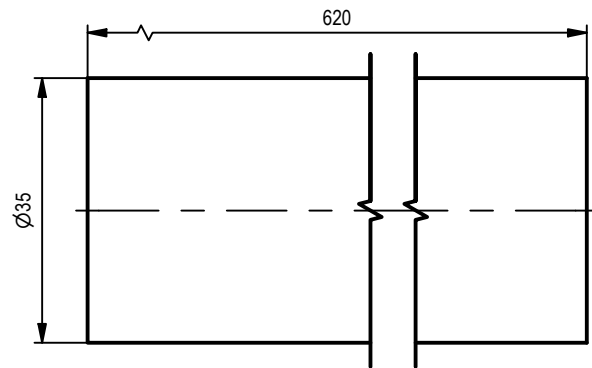
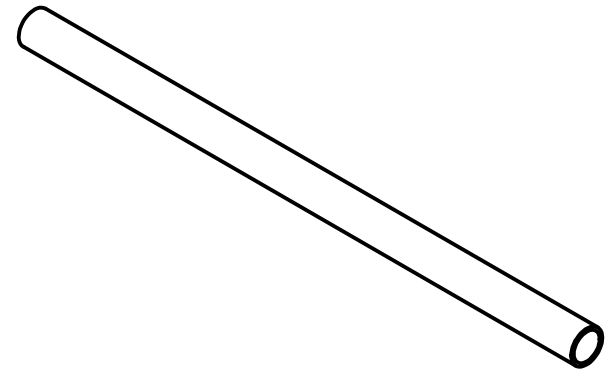

PROJECT PIPE BENDING MACHINE		CREATED BY A. PARDO		APPROVED BY D. Jaeger	
PART NAME SUB-PIPE BENDING MACHINE 3		PART CODE 3		DOCUMENT TYPE ASSEMBLY	
 Open Source Ecology e.V. Knobelsdorffstr. 22 14059 Berlin www.ose-germany.de +49 (0) 30 / 92282426		LICENSE CERN-OHL		FILE NAME SUB-PIPE BENDING MACHINE 3.iam	
		SCALE 1 / 5		VERSION 1.0	
				SHEET 13	
				DATE 26/11/2020	



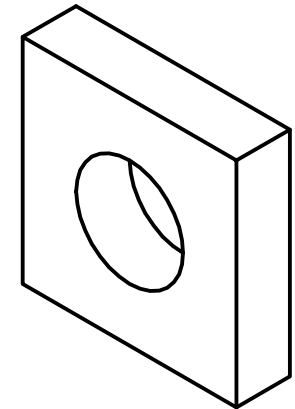
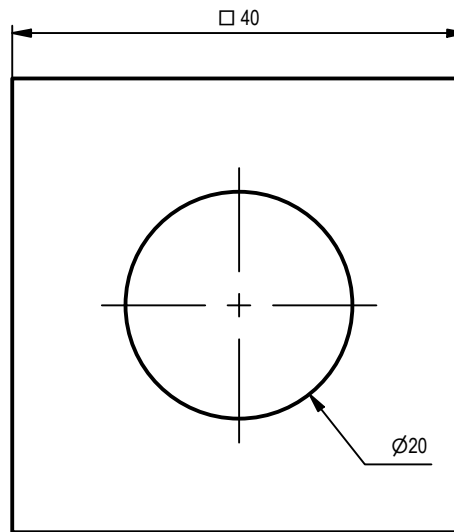

SECTION B-B
SCALE 1 : 1

PROJECT PIPE BENDING MACHINE		CREATED BY A. PARDO		APPROVED BY D. Jaeger	
PART NAME HANDLE		PART CODE 3.1		DOCUMENT TYPE Production	
 <p>Open Source Ecology e.V. Knobelsdorffstr. 22 14059 Berlin www.ose-germany.de +49 (0) 30 / 92282426</p>		LICENSE CERN-OHL		FILE NAME HANDLE.ipt	
		SCALE 1 : 1		MATERIAL Steel C45	
		VERSION 1.0		QUANTITY 1	
		SHEET 14		DATE 26/10/2020	

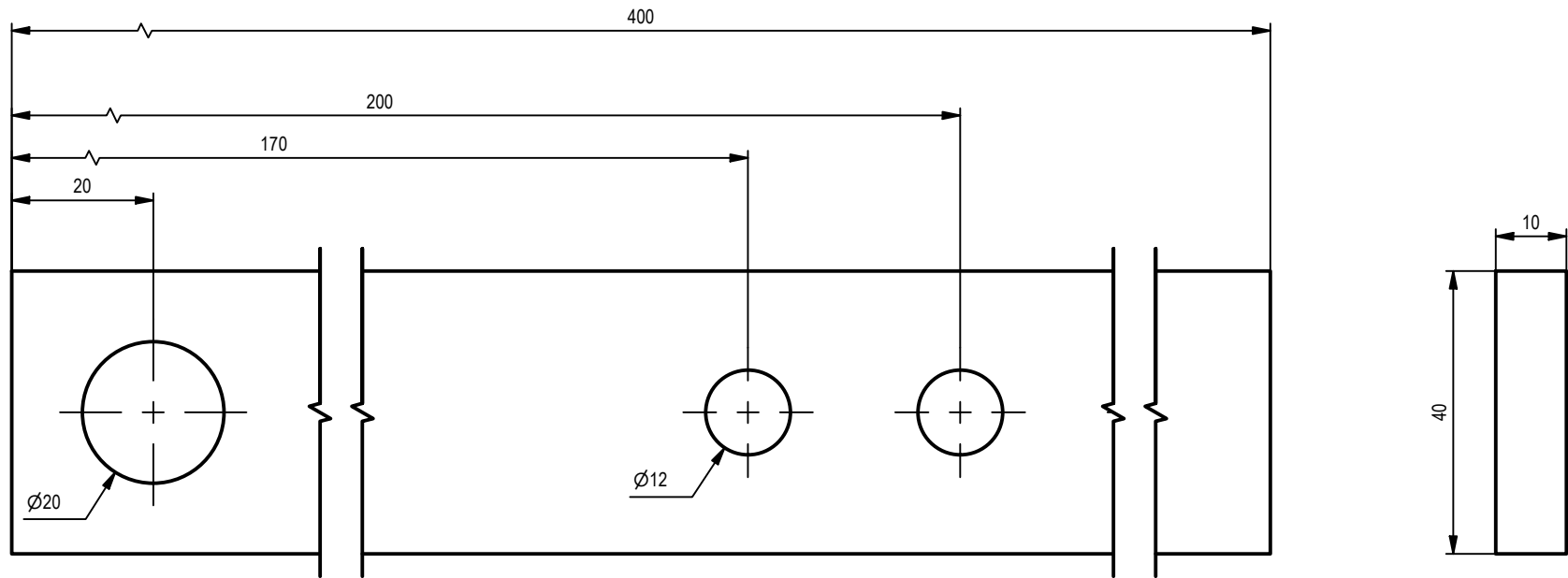
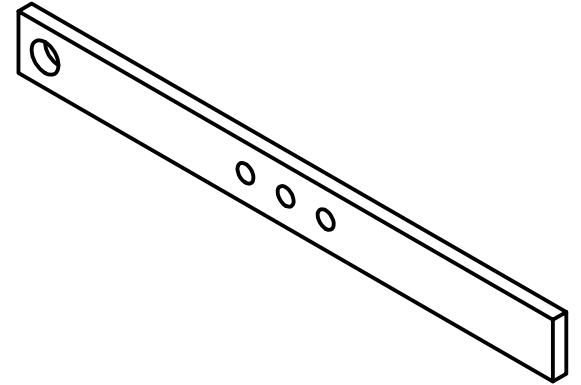

PROJECT PIPE BENDING MACHINE		CREATED BY A. PARDO		APPROVED BY D. Jaeger	
PART NAME FORMER SPACER		PART CODE 3.2		DOCUMENT TYPE Production	
 Open Source Ecology e.V. Knobelsdorffstr. 22 14059 Berlin www.ose-germany.de +49 (0) 30 / 92282426		LICENSE CERN-OHL		FILE NAME FORMER SPACER.ipt	
		SCALE 1.5 : 1		MATERIAL Steel C45	
		VERSION 1.0		QUANTITY 1	
		SHEET 15		DATE 26/10/2020	



PROJECT PIPE BENDING MACHINE		CREATED BY A. PARDO		APPROVED BY D. Jaeger	
PART NAME HANDLE ARM		PART CODE 3.3		DOCUMENT TYPE Production	
 Open Source Ecology e.V. Knobelsdorffstr. 22 14059 Berlin www.ose-germany.de +49 (0) 30 / 92282426		LICENSE CERN-OHL		FILE NAME HANDLE ARM.ipt	
		SCALE 1 : 1		MATERIAL Steel C45	
		VERSION 1.0		QUANTITY 1	
		SHEET 16		DATE 26/10/2020	

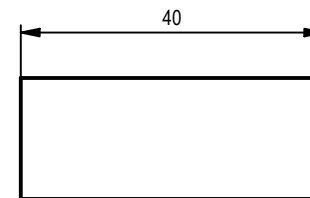
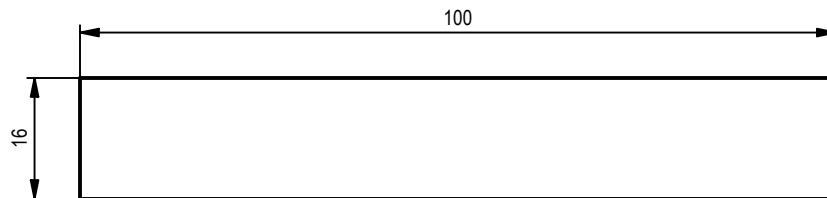
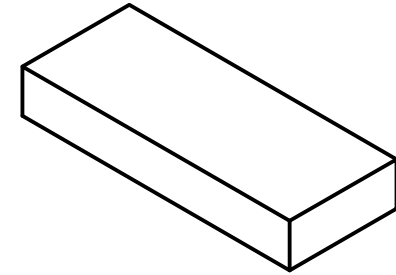

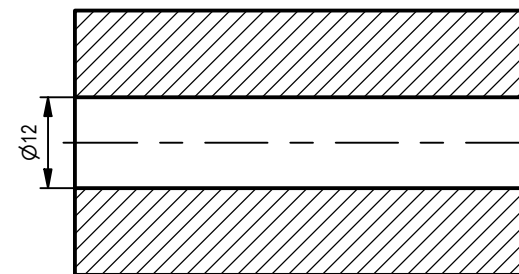
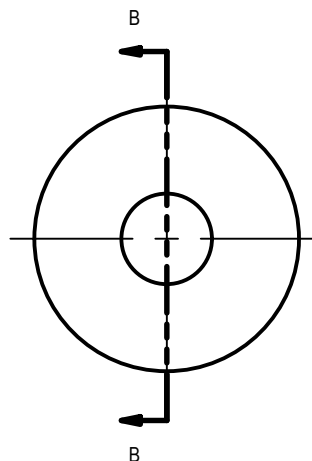
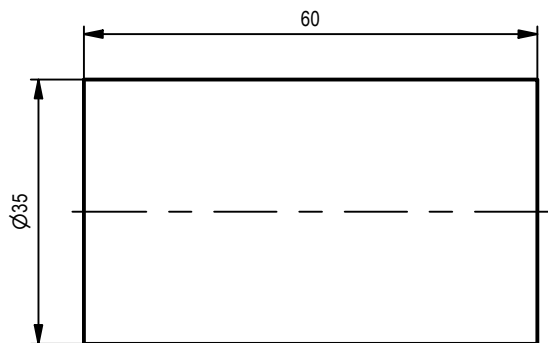
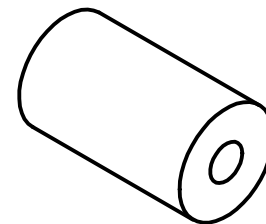

PROJECT PIPE BENDING MACHINE		CREATED BY A. PARDO		APPROVED BY D. Jaeger	
PART NAME HANDLE SPACER		PART CODE 3.4		DOCUMENT TYPE Production	
 Open Source Ecology e.V. Knobelsdorffstr. 22 14059 Berlin www.ose-germany.de +49 (0) 30 / 92282426		LICENSE CERN-OHL		MATERIAL Steek C45	
		FILE NAME HANDLE SPACER.ipt		VERSION 1.0	
		SCALE 1 : 1		SHEET 17	
				DATE 26/10/2020	



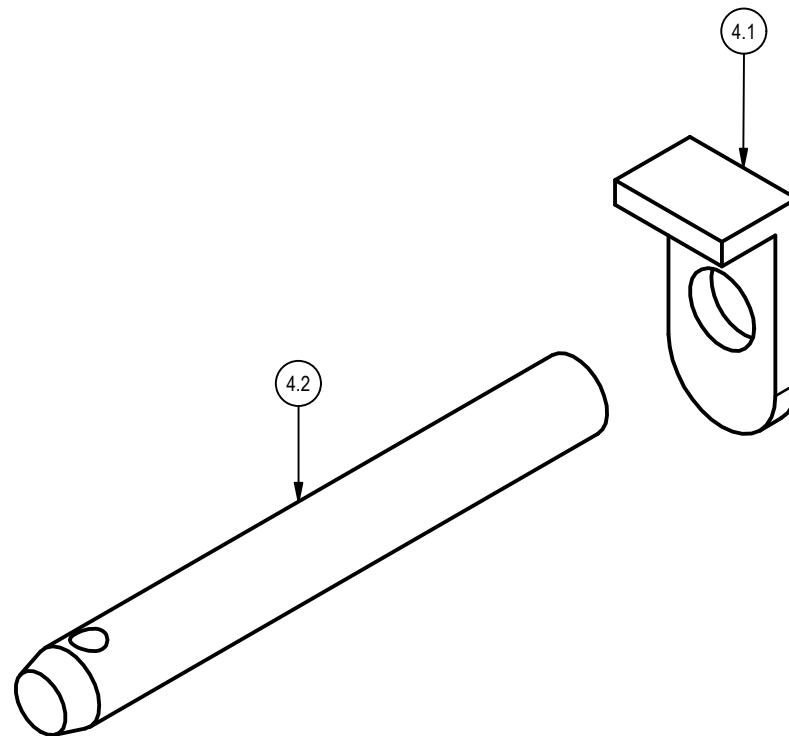

SECTION B-B
SCALE 1 : 1

PROJECT PIPE BENDING MACHINE		CREATED BY A. PARDO		APPROVED BY D. Jaeger	
PART NAME ROLLER		PART CODE 3.5		DOCUMENT TYPE Production	
 Open Source Ecology e.V. Knobelsdorffstr. 22 14059 Berlin www.ose-germany.de +49 (0) 30 / 92282426		LICENSE CERN-OHL		MATERIAL Steel C45	
		FILE NAME ROLLER.ipt		VERSION 1.0	
		SCALE 1 : 1		SHEET 18	
				DATE 26/10/2020	

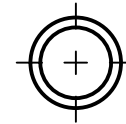
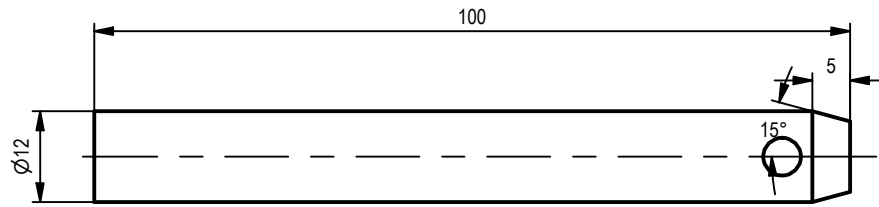
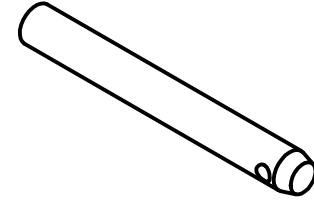

PROJECT PIPE BENDING MACHINE		CREATED BY A. PARDO		APPROVED BY D. Jaeger	
PART NAME SUB-PIPE BENDING MACHINE 4		PART CODE 4	DOCUMENT TYPE ASSEMBLY		MATERIAL
 Open Source Ecology e.V. Knobelsdorffstr. 22 14059 Berlin www.ose-germany.de +49 (0) 30 / 92282426		LICENSE CERN-OHL	FILE NAME SUB-PIPE BENDING MACHINE 4.iam	VERSION 1.0	QUANTITY 1
			SCALE 1 : 1	SHEET 19	DATE 26/11/2020



PROJECT PIPE BENDING MACHINE		CREATED BY A. PARDO		APPROVED BY D. Jaeger		
PART NAME ROLLER PIN		PART CODE 4.1	DOCUMENT TYPE Production		MATERIAL Steel C45	
 Open Source Ecology e.V. Knobelsdorffstr. 22 14059 Berlin www.ose-germany.de +49 (0) 30 / 92282426		LICENSE CERN-OHL	FILE NAME ROLLER PIN.ipt		VERSION 1.0	QUANTITY 1
			SCALE 1 : 1	SHEET 20	DATE 26/10/2020	

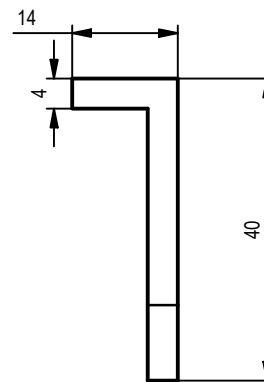
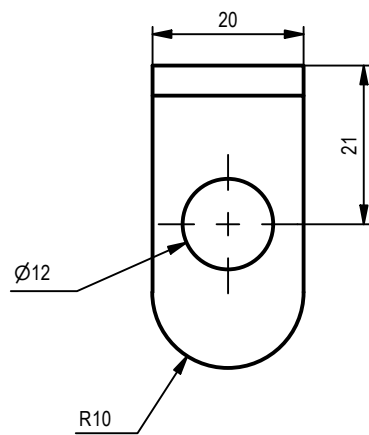
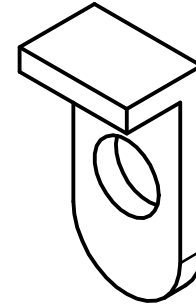

PROJECT PIPE BENDING MACHINE		CREATED BY A. PARDO		APPROVED BY D. Jaeger	
PART NAME PIN HANDLE		PART CODE 4.2		DOCUMENT TYPE Production	
 Open Source Ecology e.V. Knobelsdorffstr. 22 14059 Berlin www.ose-germany.de +49 (0) 30 / 92282426		LICENSE CERN-OHL		MATERIAL Steel C45	
		FILE NAME PIN HANDLE.ipt		VERSION 1.0	
		SCALE 1 : 1		SHEET 21	
				DATE 26/10/2020	

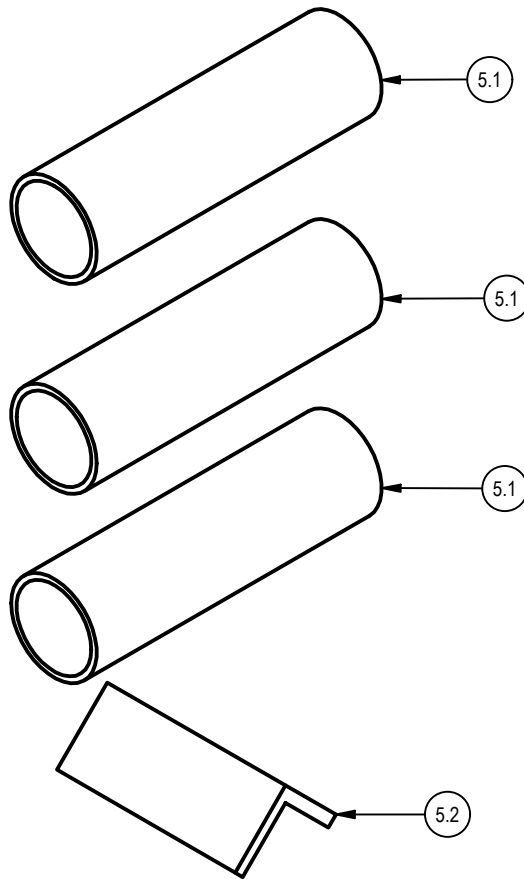

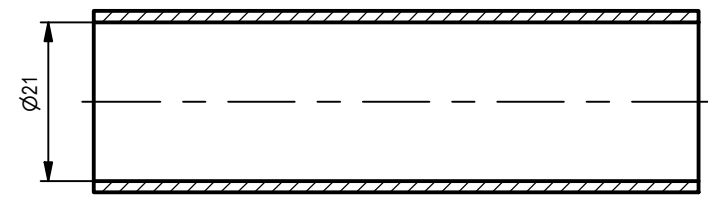
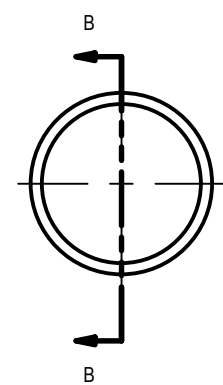
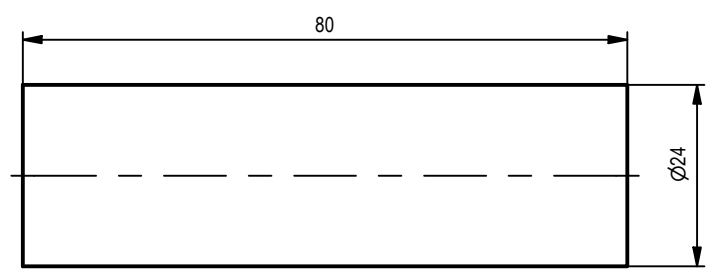
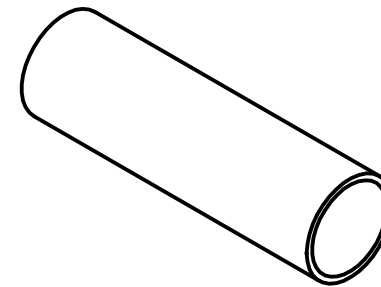

PROJECT PIPE BENDING MACHIN		CREATED BY A. PARDO		APPROVED BY D. Jaeger	
PART NAME SUB-PIPE BENDING MACHINE 5		PART CODE 5		DOCUMENT TYPE ASSEMBLY	
 Open Source Ecology e.V. Knobelsdorffstr. 22 14059 Berlin www.ose-germany.de +49 (0) 30 / 92282426		LICENSE CERN-OHL		FILE NAME SUB-PIPE BENDING MACHINE 5.iam	
				SCALE 1 / 1.5	
		VERSION 1.0		QUANTITY 1	
		SHEET 22		DATE 26/11/2020	



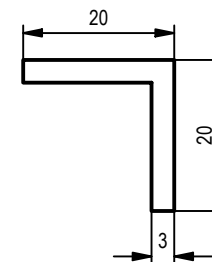
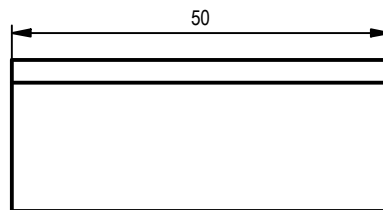
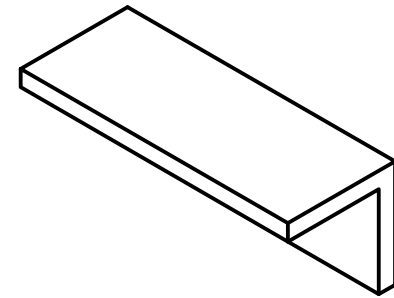

SECTION B-B
SCALE 1 : 1

PROJECT PIPE BENDING MACHINE		CREATED BY A. PARDO		APPROVED BY D. Jaeger	
PART NAME STOP TUBE		PART CODE 5.1		DOCUMENT TYPE Production	
 Open Source Ecology e.V. Knobelsdorffstr. 22 14059 Berlin www.ose-germany.de +49 (0) 30 / 92282426		LICENSE CERN-OHL		MATERIAL Steel C45	
		FILE NAME STOP TUBE.ipt		VERSION 1.0	
		SCALE 1 : 1		SHEET 23	
				DATE 26/10/2020	

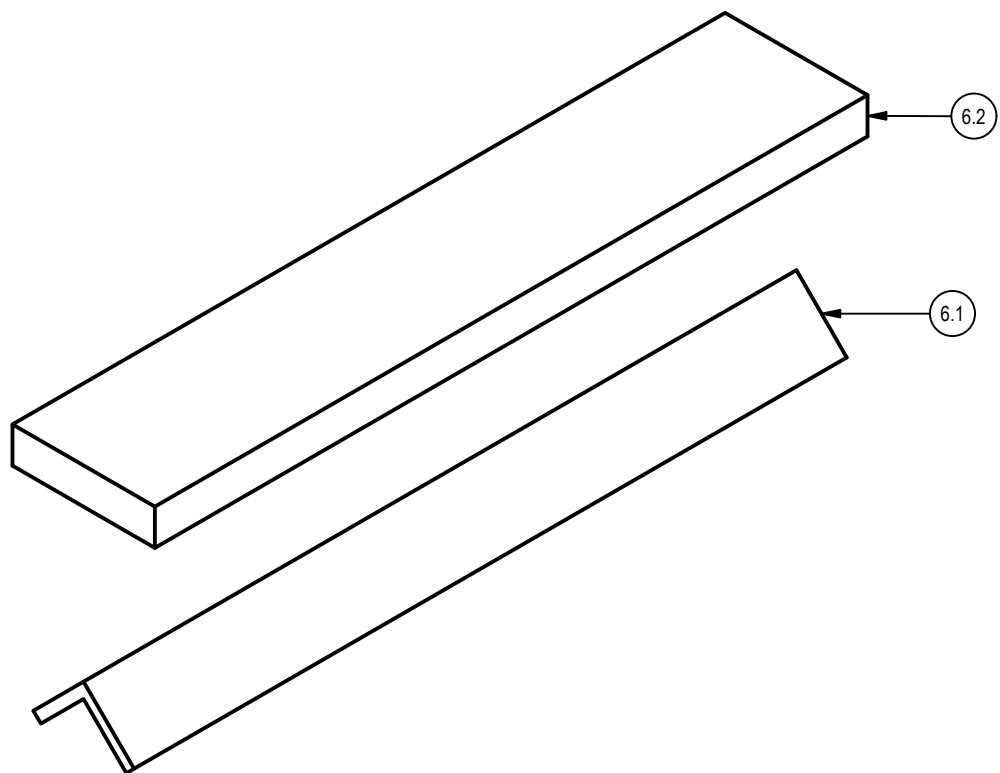

PROJECT PIPE BENDING MACHINE		CREATED BY A. PARDO		APPROVED BY D. Jaeger	
PART NAME STOP ANGLE		PART CODE 5.2		DOCUMENT TYPE Production	
 Open Source Ecology e.V. Knobelsdorffstr. 22 14059 Berlin www.ose-germany.de +49 (0) 30 / 92282426		LICENSE CERN-OHL		FILE NAME STOP ANGLE.ipt	
		SCALE 1 : 1		MATERIAL Steel C45	
		VERSION 1.0		QUANTITY 1	
		SHEET 24		DATE 26/10/2020	



PROJECT PIPE BENDING MACHINE		CREATED BY A. PARDO		APPROVED BY D. Jaeger	
PART NAME SUB-PIPE BENDING MACHINE 6		PART CODE 6	DOCUMENT TYPE ASSEMBLY		MATERIAL
 Open Source Ecology e.V. Knobelsdorffstr. 22 14059 Berlin www.ose-germany.de +49 (0) 30 / 92282426		LICENSE CERN-OHL	FILE NAME SUB-PIPE BENDING MACHINE 6.iam	VERSION 1.0	QUANTITY 1
			SCALE 1 / 1.5	SHEET 25	DATE 26/11/2020

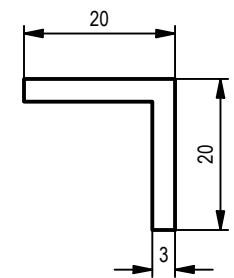
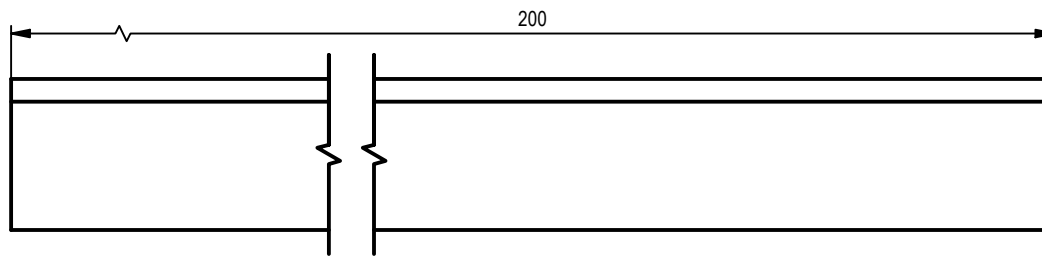
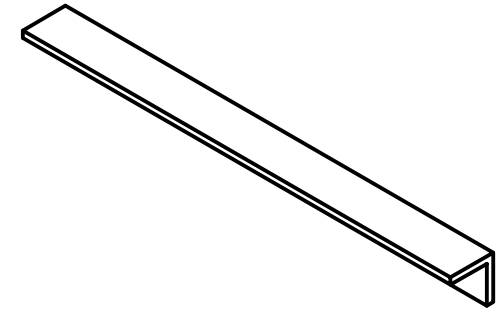

PROJECT PIPE BENDING MACHINE		CREATED BY A. PARDO		APPROVED BY D. Jaeger	
PART NAME GUIDE ANGLE		PART CODE 6.1		DOCUMENT TYPE Production	
 Open Source Ecology e.V. Knobelsdorffstr. 22 14059 Berlin www.ose-germany.de +49 (0) 30 / 92282426		LICENSE CERN-OHL		FILE NAME GUIDE ANGLE.ipt	
		SCALE 1 : 1		MATERIAL Steel C45	
		VERSION 1.0		QUANTITY 1	
		SHEET 26		DATE 26/10/2020	

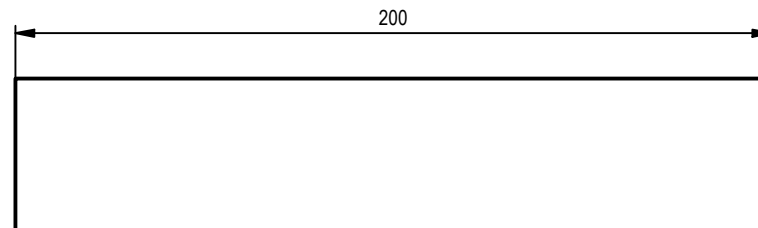
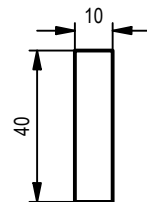
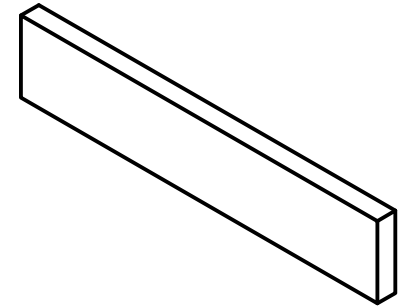

PROJECT PIPE BENDING MACHINE		CREATED BY A. PARDO		APPROVED BY D. Jaeger		
PART NAME GUIDE BASE		PART CODE 6.2	DOCUMENT TYPE Production		MATERIAL Steel C45	
 Open Source Ecology e.V. Knobelsdorffstr. 22 14059 Berlin www.ose-germany.de +49 (0) 30 / 92282426		LICENSE CERN-OHL	FILE NAME GUIDE BASE.ipt		VERSION 1.0	QUANTITY 1
			SCALE 1 / 2	SHEET 27	DATE 26/10/2020	

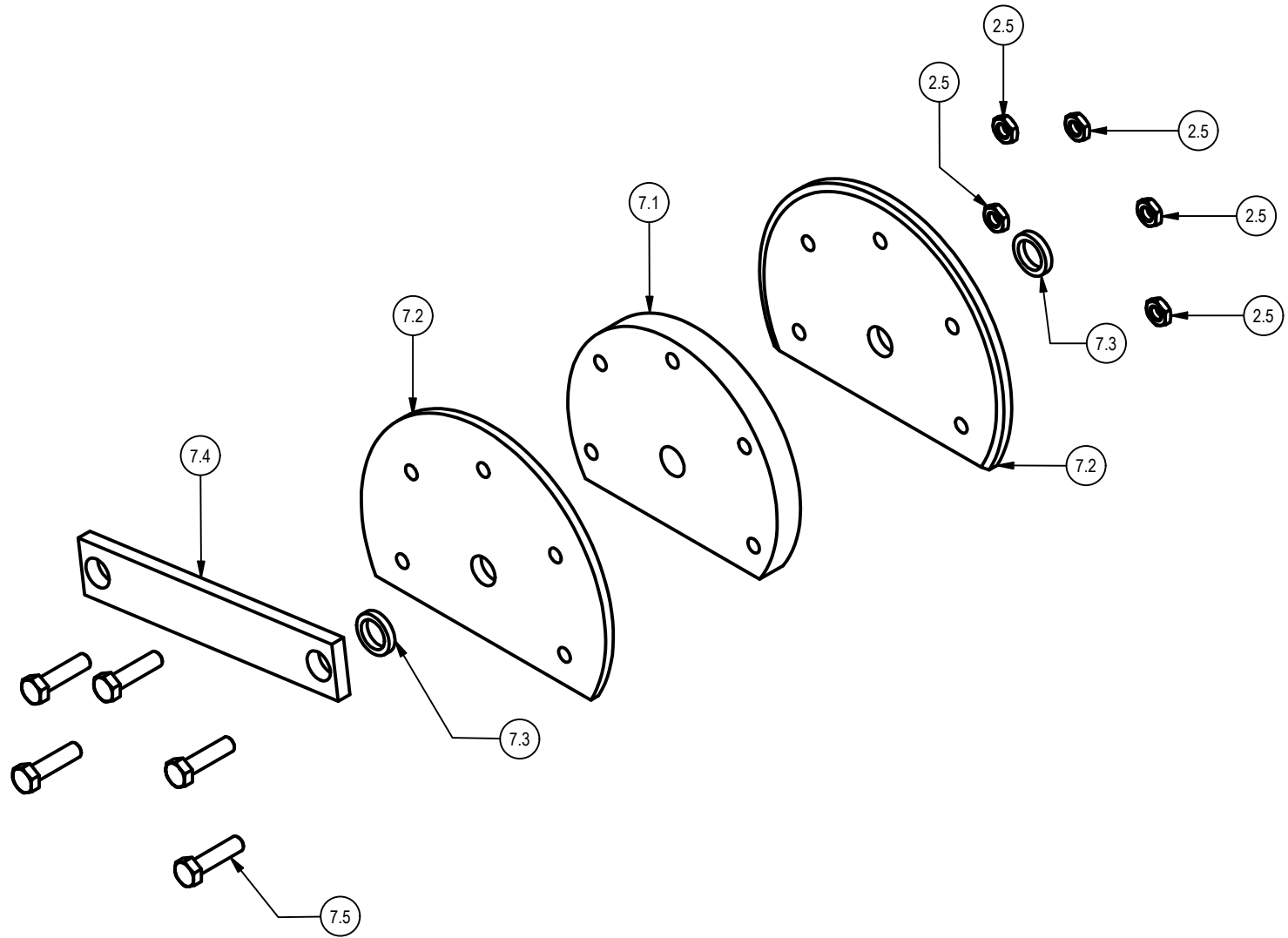

PROJECT PIPE BENDING MACHINE		CREATED BY A. PARDO		APPROVED BY D. Jaeger	
PART NAME SUB-PIPE BENDING MACHINE 7		PART CODE 7		DOCUMENT TYPE ASSEMBLY	
 Open Source Ecology e.V. Knobelsdorffstr. 22 14059 Berlin www.ose-germany.de +49 (0) 30 / 92282426		LICENSE CERN-OHL		FILE NAME SUB-PIPE BENDING MACHINE 7.iam	
		SCALE 1 / 4		VERSION 1.0	
				SHEET 28	
				DATE 26/11/2020	

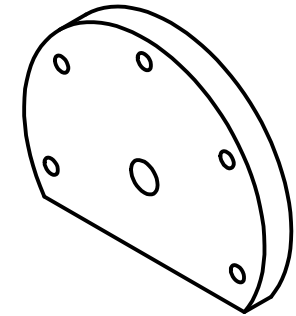
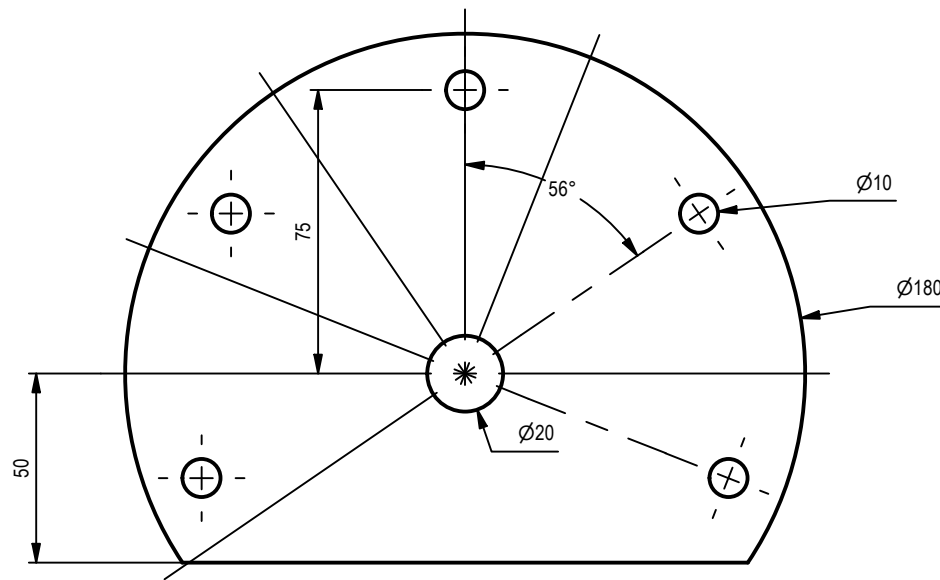

PROJECT PIPE BENDING MACHINE		CREATED BY A. PARDO		APPROVED BY D. Jaeger	
PART NAME FORMER SIDE		PART CODE 7.1		DOCUMENT TYPE Production	
 Open Source Ecology e.V. Knobelsdorffstr. 22 14059 Berlin www.ose-germany.de +49 (0) 30 / 92282426		LICENSE CERN-OHL		FILE NAME FORMER BASE.ipt	
		SCALE 1 / 2		MATERIAL Steel C45	
		VERSION 1.0		QUANTITY 1	
		SHEET 29		DATE 26/10/2020	

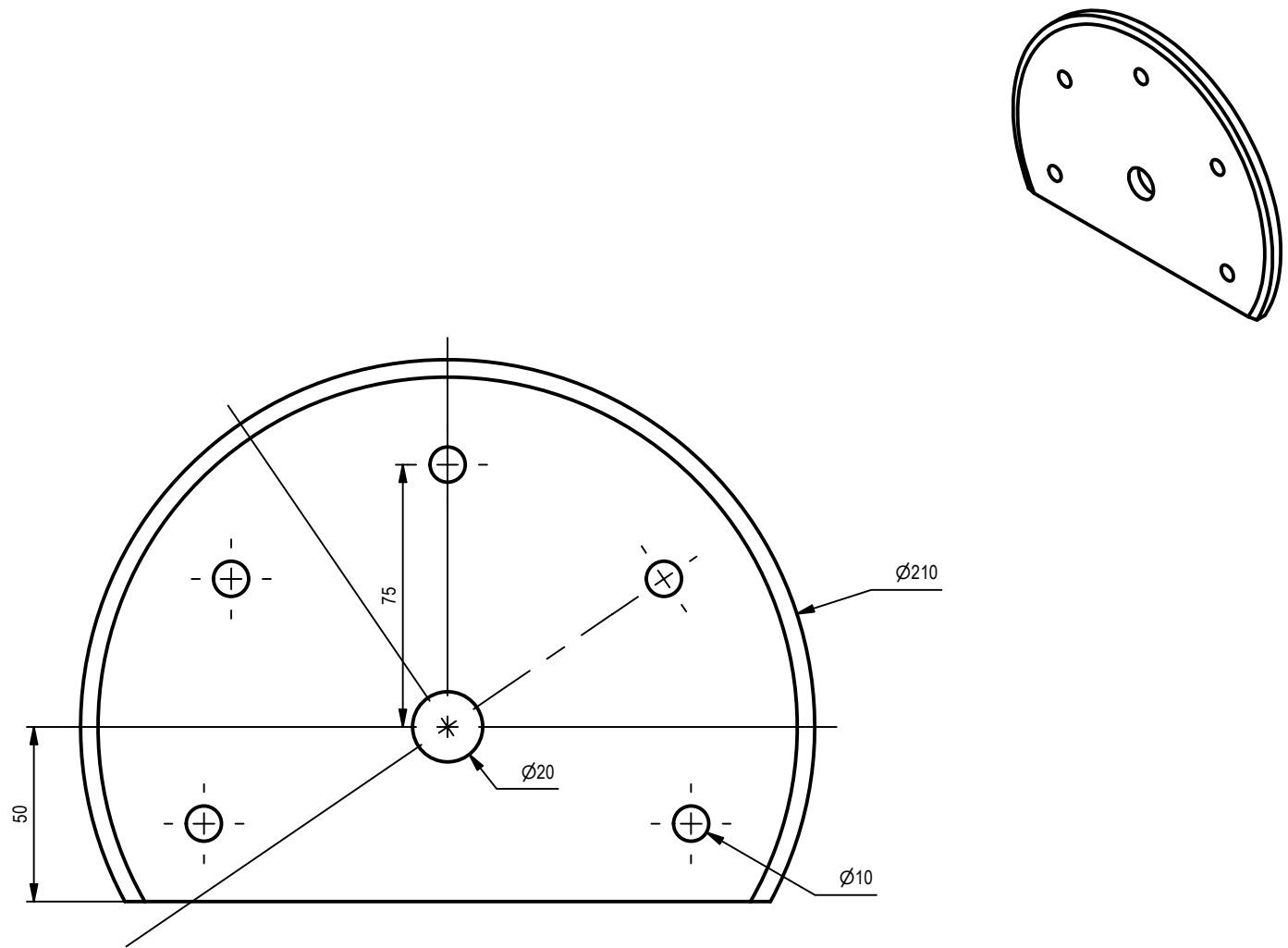
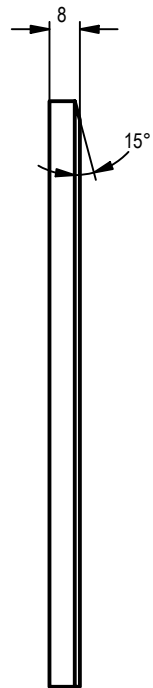

PROJECT PIPE BENDING MACHINE		CREATED BY A. PARDO		APPROVED BY D. Jaeger	
PART NAME FORMER SIDE		PART CODE 7.2		DOCUMENT TYPE Production	
 Open Source Ecology e.V. Knobelsdorffstr. 22 14059 Berlin www.ose-germany.de +49 (0) 30 / 92282426		LICENSE CERN-OHL		FILE NAME FORMER SIDE.ipt	
		SCALE 1 / 2		MATERIAL Steel C45	
		VERSION 1.0		QUANTITY 1	
		SHEET 30		DATE 26/10/2020	

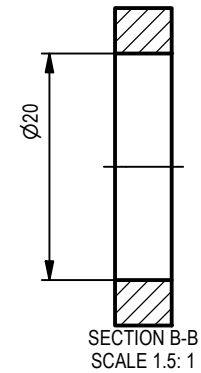
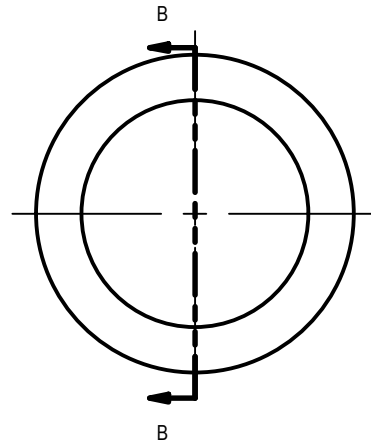
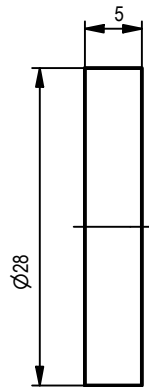
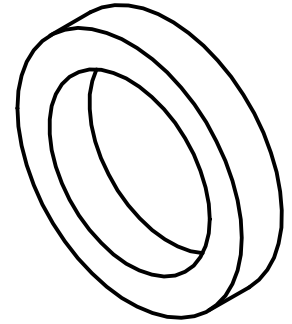

PROJECT PIPE BENDING MACHINE		CREATED BY A. PARDO		APPROVED BY D. Jaeger	
PART NAME SPACER TUBE		PART CODE 7.3		DOCUMENT TYPE Production	
 <p>Open Source Ecology e.V. Knobelsdorffstr. 22 14059 Berlin www.ose-germany.de +49 (0) 30 / 92282426</p>		LICENSE CERN-OHL		MATERIAL Steel C45	
		FILE NAME SPACER TUBE.ipt		VERSION 1.0	
		SCALE 1.5: 1		SHEET 31	
				DATE 26/10/2020	

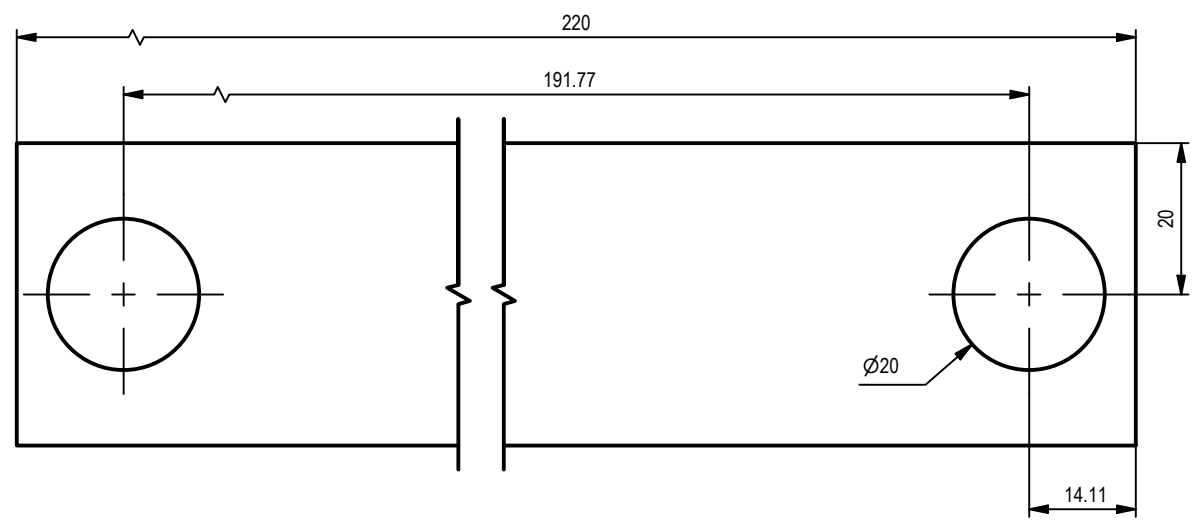
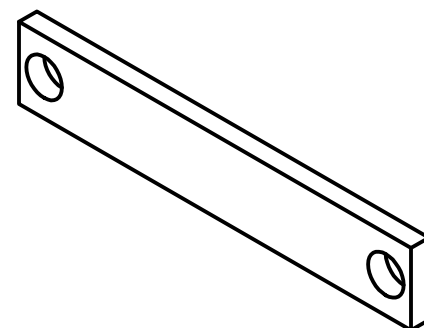

PROJECT PIPE BENDING MACHINE		CREATED BY A. PARDO		APPROVED BY D. Jaeger		
PART NAME PIN LINK		PART CODE 7.4	DOCUMENT TYPE Production		MATERIAL Steel C45	
 Open Source Ecology e.V. Knobelsdorffstr. 22 14059 Berlin www.ose-germany.de +49 (0) 30 / 92282426		LICENSE CERN-OHL	FILE NAME PIN LINK.ipt		VERSION 1.0	QUANTITY 1
			SCALE 1:1	SHEET 32	DATE 26/10/2020	