

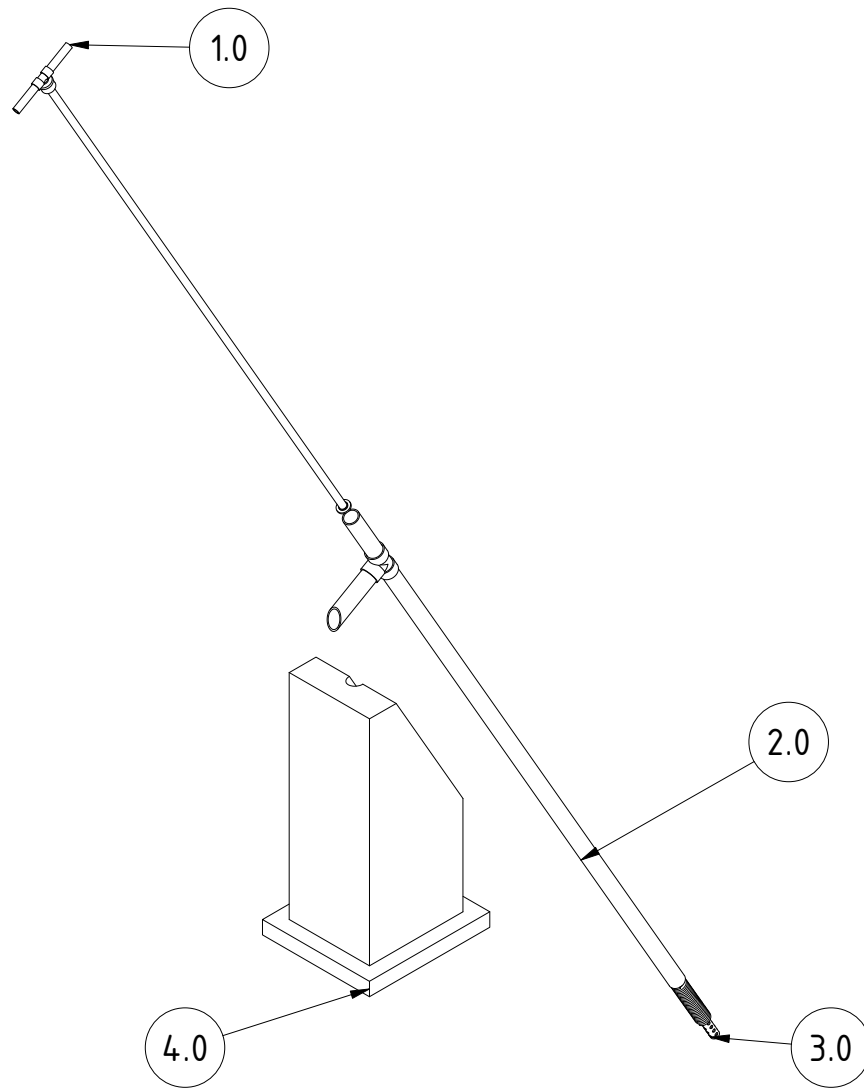

Note: All units in mm.

PROJECT	CREATED BY	APPROVED BY	DATE	VERSION
DTU Handpump	J. Rosciano	A. Morillo	17/06/2021	1.1
PART NAME	FILE NAME			POS
3d views	uwd_dhp_dtu-handpump.iam			A1
DEVELOPED BY	REDESIGNED BY	DOC. TYPE	MATERIAL	QUANTITY
		Assembly		1
University of Warwick, DTU OHO e.V.		LICENCE	SCALE	SHEET
		CC-BY-SA 4.0	1/16	1 /23



PROJECT	CREATED BY	APPROVED BY	DATE	VERSION
DTU Handpump	J. Rosciano	A. Morillo	17/06/2021	1.1
PART NAME	FILE NAME			POS
Exploded 3d view	uwd_dhp_dtu-handpump.ipn			A2
DEVELOPED BY	REDESIGNED BY	DOC. TYPE	MATERIAL	QUANTITY
		Assembly		1
University of Warwick, DTU	OHO e.V.	LICENCE	SCALE	SHEET
		CC-BY-SA 4.0	1/20	2 /23

Parts list

POS	QTY	PART NAME	FILE NAME	PART TYPE	SPECIFICATIONS	SHEET
A1	1	3d views	uwd_dhp_dtu-handpump.iam	Assembly		1
A2	1	Exploded 3d view	uwd_dhp_dtu-handpump.ipn	Assembly		2
B1	1	Parts list	uwd_dhp_dtu-handpump.csv	Assembly		3
C1	1	Technical notes		Assembly		4
1.0	1	Internal assembly	1.0_Internal_Assembly.iam	Assembly		5-6
1.1	1	Tee	1.1_Tee.ipt	Standard	1/2" PVC	
1.2	2	Handles	1.2_Handles.ipt	Production	1/2" PVC Pipe x 4" long	7
1.3	1	Pull rod bush	1.3_Pull_Rod_Bush.ipt	Production	Hardwood	8
1.4	1	Pull rod	1.4_Pull_Rod.ipt	Production	1/2" PVC Pipe	9
1.5	1	Piston screw	1.5_Piston_Screw.ipt	Standard	3/8" BSW x 3/4"	
1.6	1	Washer 1	1.6_Washer_1.ipt	Production	OD 1" ID 3/8"	10
1.7	1	Piston	1.7_Piston.ipt	Standard	Leather	
1.8	1	Washer 2	1.8_Washer_2.ipt	Production	OD 1 1/4" ID 3/8" inside	11
1.9	1	Nut	1.9_Nut.ipt	Standard	3/8" BSW	
2.0	1	External assembly	2.0_External_Assembly.iam	Assembly		12-13
2.1	1	Top tube	2.1_Top_Tube.ipt	Production	OD 1 1/2" PVC x 8"	14
2.2	1	Tee 2	2.2_Tee_2.ipt	Standard	1 1/2" PVC	
2.3	1	Outlet	2.3_Outlet.ipt	Production	OD 1 1/2" PVC x 8" long	15
2.4	1	Rising main	2.4_Rising_Main.ipt	Production	1 1/2" PVC x 86" long	16
3.0	1	Valve	3.0_Valve.iam	Assembly		17-18
3.1	1	Piece of wood	3.1_Piece_Of_Wood.ipt	Production	Hardwood	19
3.2	1	Rubber strip	3.2_Rubber_Strip.ipt	Buy	Rubber	
3.3	1	Peforated tube	3.3_Peforated_Tube.ipt	Production	OD 3/4" PVC x 8"	20
3.4	1	Bicycle tube	3.4_Bicycle_Tube.ipt	Production	OD 33.7 ASTM A36	21
3.5	1	Rubber	3.5_Rubber.ipt	Production	Rubber	22
3.6	1	Screw.ipt	3.6_Screw.ipt	Standard	ISO 14586 ST2.9x6.5	
4.0	1	Concrete support	4.0_Concrete_Support.ipt	Production	Concrete	23

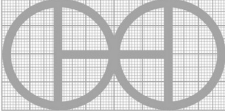
PROJECT		CREATED BY		APPROVED BY		DATE		VERSION		
DTU Handpump		J. Rosciano		A. Morillo		17/06/2021		1.1		
PART NAME			FILE NAME					POS		
Parts list								B1		
DEVELOPED BY			REDESIGNED BY			DOC. TYPE		MATERIAL		QUANTITY
						Parts list				
University of Warwick, DTU			OHO e.V.			LICENCE		SCALE		SHEET
						CC-BY-SA 4.0				3 /23

TECHNICAL NOTES

NOTES	CONTENT
GENERAL NOTES	
Foundations fixing	<ul style="list-style-type: none"> - The ground must be stable and have a low water table. - The structure must be fixed on firm oncrete soil or on poured footings with steel reinforcement. - The anchorage can be bolted with expansive ramplugs or welded.
Wood treatment	<ul style="list-style-type: none"> - The wood must be treated with pesticides and kiln-dried to ensure adequate humidity. - Wood sealer should be applied for later use.

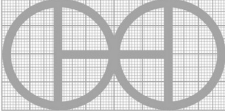
PROJECT	CREATED BY	APPROVED BY	DATE	VERSION
DTU Handpump	J. Rosciano	A. Morillo	17/06/2021	1.1
PART NAME	FILE NAME			POS
Technical notes				C1
DEVELOPED BY	REDESIGNED BY	DOC. TYPE	MATERIAL	QUANTITY
		Technical notes		
University of Warwick, DTU	OHO e.V.	LICENCE	SCALE	SHEET
		CC-BY-SA 4.0		4 /23

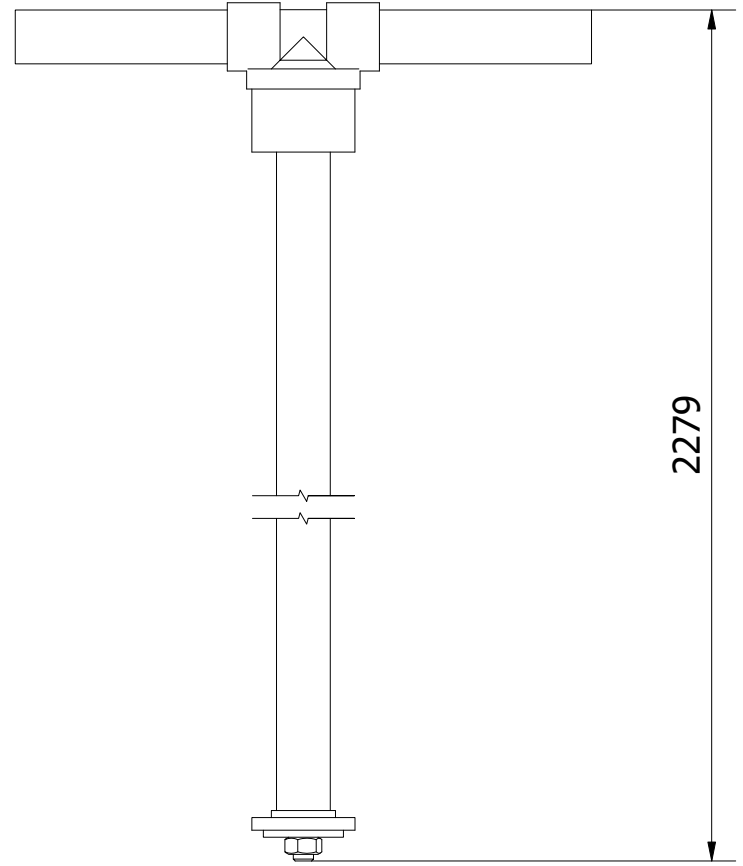
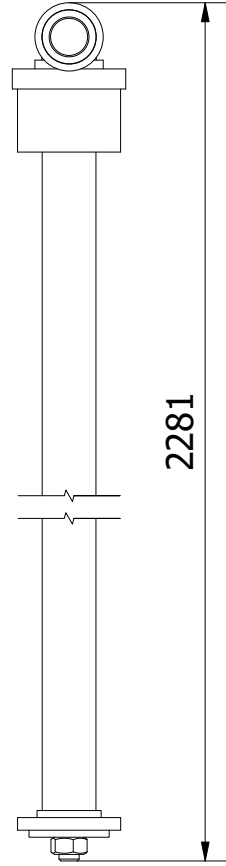
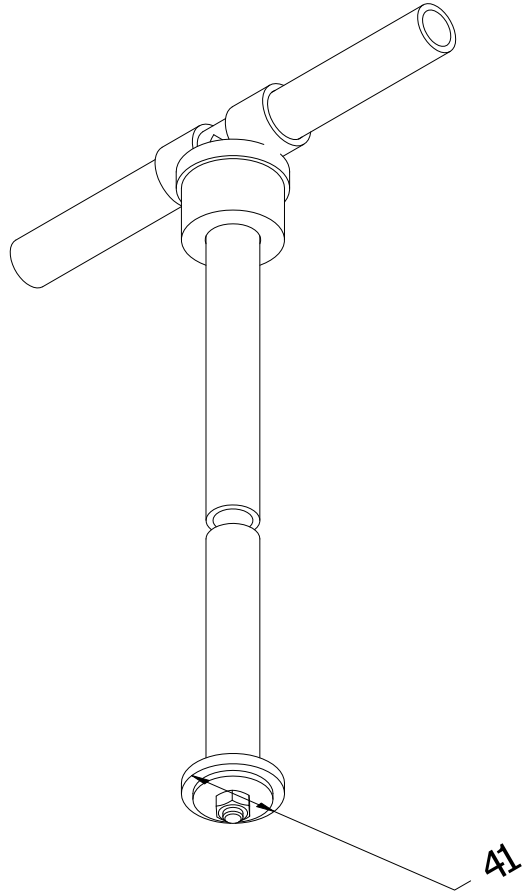

Note: All units in mm.

PROJECT	CREATED BY	APPROVED BY	DATE	VERSION
DTU Handpump	J. Rosciano	A. Morillo	17/06/2021	1.1
PART NAME	FILE NAME			POS
Internal assembly	1.0_Internal_Assembly.iam			1.0
DEVELOPED BY	REDESIGNED BY	DOC. TYPE	MATERIAL	QUANTITY
		Assembly		1
University of Warwick, DTUOHO e.V.		LICENCE	SCALE	SHEET
		CC-BY-SA 4.0	1/3	5 /23

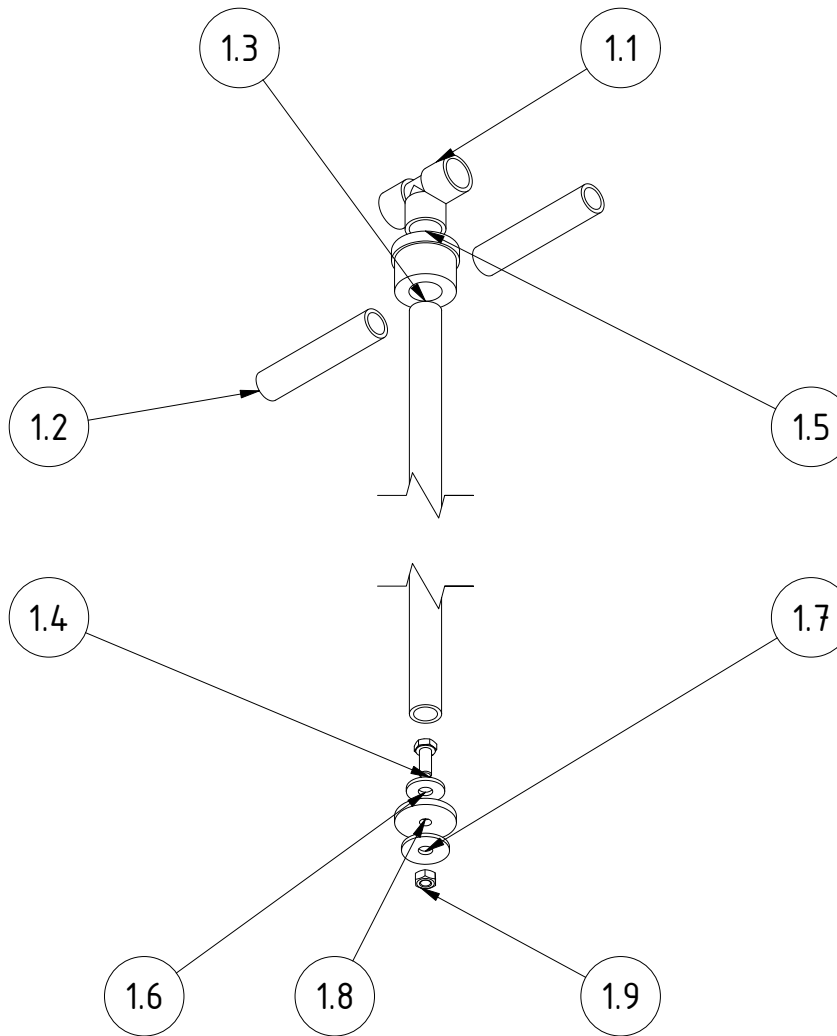

Note: All units in mm.

PROJECT	CREATED BY	APPROVED BY	DATE	VERSION
DTU Handpump	J. Rosciano	A. Morillo	17/06/2021	1.1
PART NAME	FILE NAME			POS
Internal assembly	1.0_Internal_Assembly.ipn			1.0
DEVELOPED BY	REDESIGNED BY	DOC. TYPE	MATERIAL	QUANTITY
		Assembly		1
University of Warwick, DTU	OHO e.V.	LICENCE	SCALE	SHEET
		CC-BY-SA 4.0	1/5	6 /23

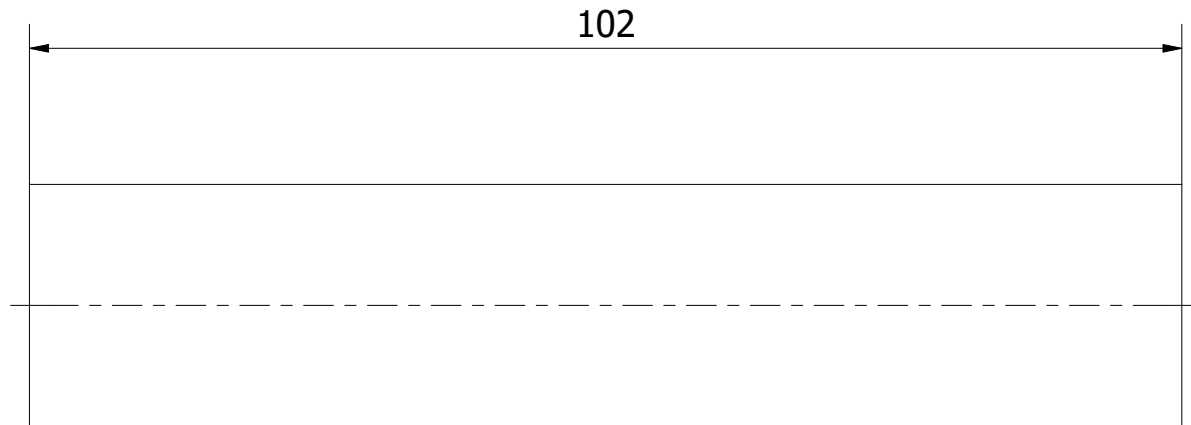
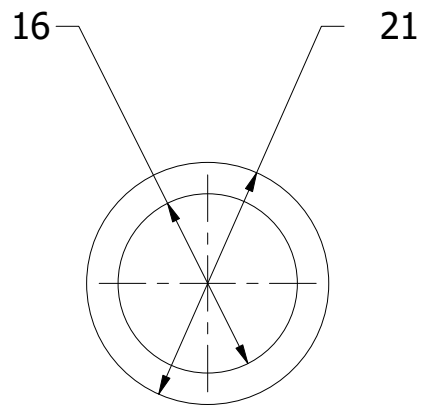

Note: All units in mm.

PROJECT	CREATED BY	APPROVED BY	DATE	VERSION
DTU Handpump	J. Rosciano	A. Morillo	17/06/2021	1.1
PART NAME	FILE NAME			POS
Handles	1.2_Handles.ipt			1.2
DEVELOPED BY	REDESIGNED BY	DOC. TYPE	MATERIAL	QUANTITY
		Part	PVC	2
		LICENCE	SCALE	SHEET
University of Warwick, DTU	OHO e.V.	CC-BY-SA 4.0	1.5/1	7 /23

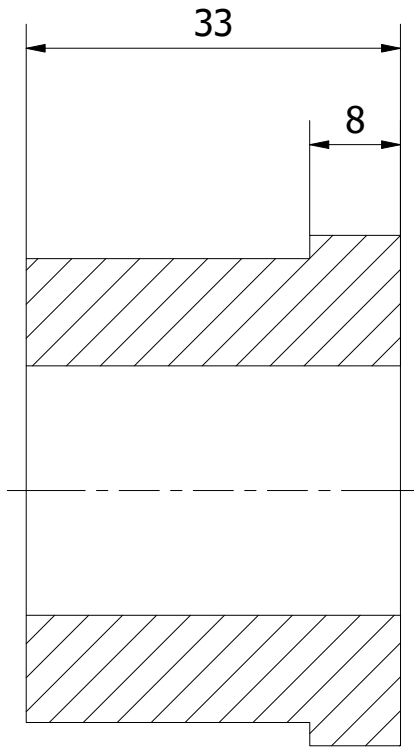

A-A (1.5/1)

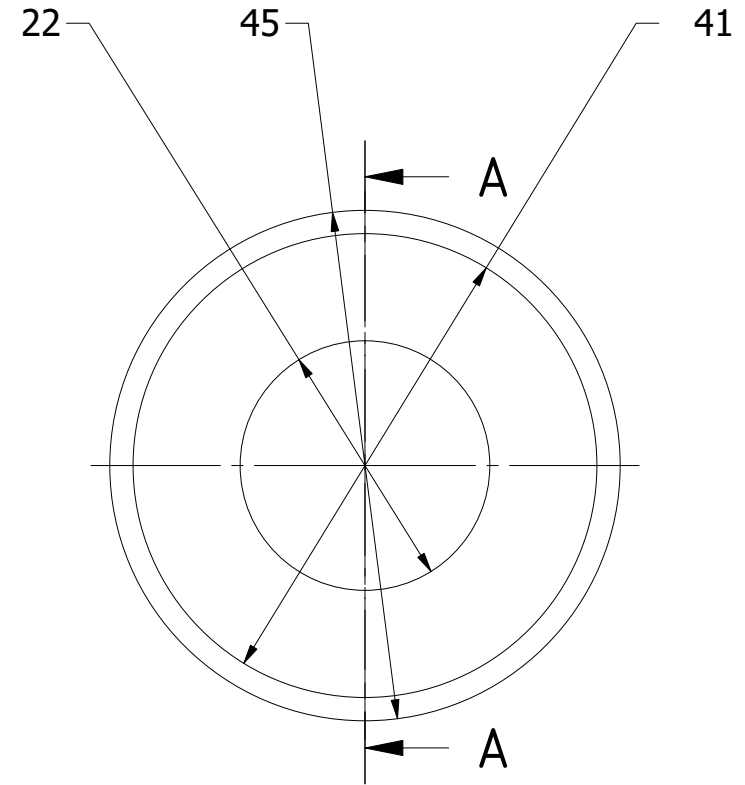

Note: All units in mm.

PROJECT	CREATED BY	APPROVED BY	DATE	VERSION
DTU Handpump	J. Rosciano	A. Morillo	17/06/2021	1.1
PART NAME	FILE NAME			POS
Pull rod bush	1.3_Pull_Rod_Bush.ipt			1.3
DEVELOPED BY	REDESIGNED BY	DOC. TYPE	MATERIAL	QUANTITY
		Part	Hardwood	1
University of Warwick, DTU	OHO e.V.	LICENCE	SCALE	SHEET
		CC-BY-SA 4.0	1.5/1	8 /23

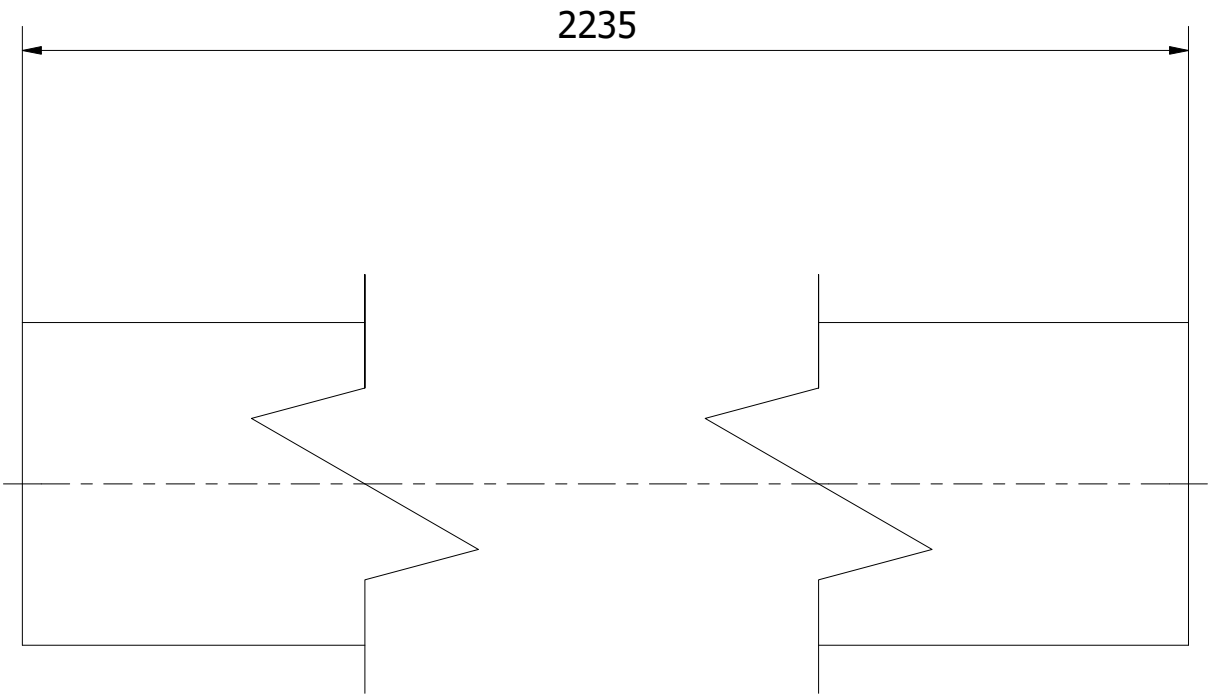
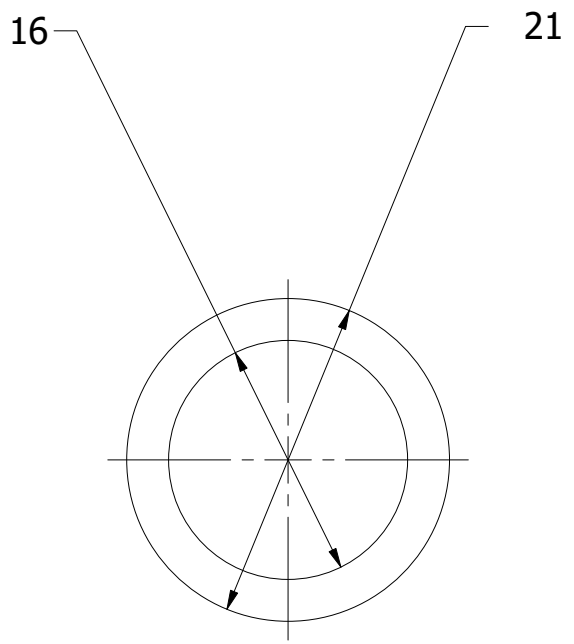

Note: All units in mm.

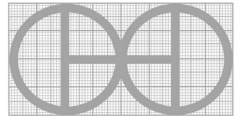
PROJECT	CREATED BY	APPROVED BY	DATE	VERSION
DTU Handpump	J. Rosciano	A. Morillo	17/06/2021	1.1
PART NAME	FILE NAME			POS
Pull rod	1.4_Pull_Rod.ipt			1.4
DEVELOPED BY	REDESIGNED BY	DOC. TYPE	MATERIAL	QUANTITY
		Part	PVC	1
		LICENCE	SCALE	SHEET
University of Warwick, DTU	OHO e.V.	CC-BY-SA 4.0	2/1	9 /23

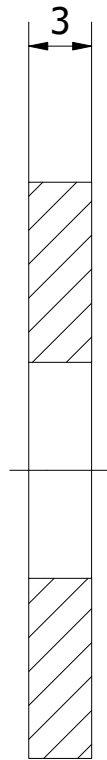

B-B (3 : 1)

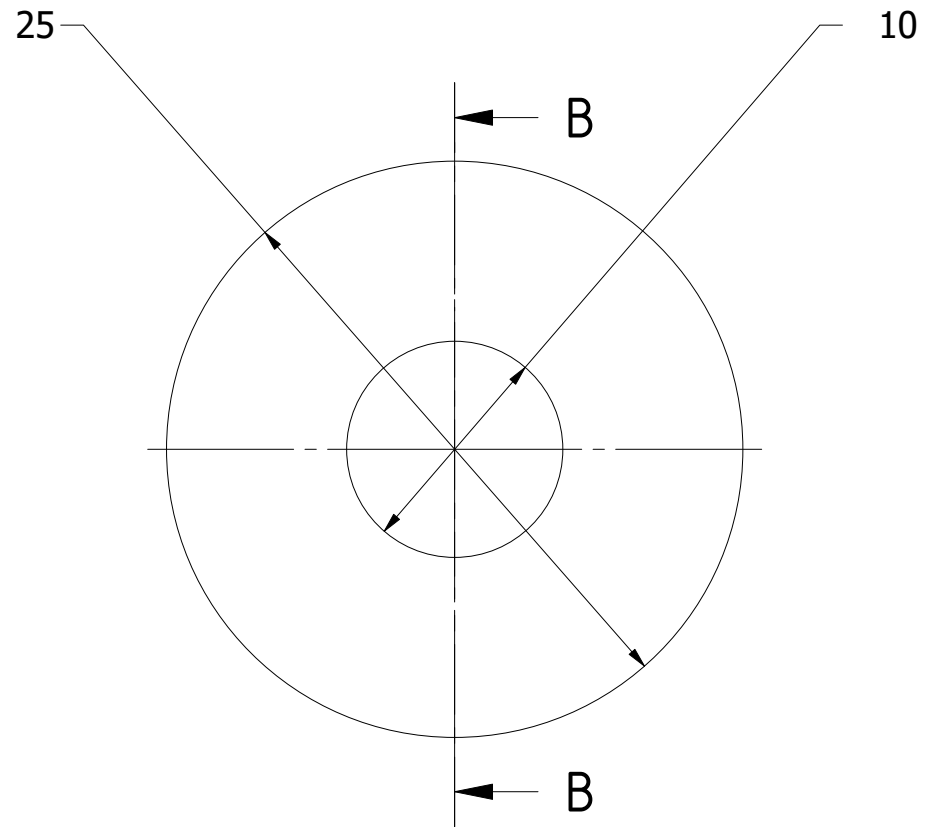

Note: All units in mm.

PROJECT	CREATED BY	APPROVED BY	DATE	VERSION
DTU Handpump	J. Rosciano	A. Morillo	17/06/2021	1.1
PART NAME	FILE NAME			POS
Washer 1	1.6_Washer.ipt			1.6
DEVELOPED BY	REDESIGNED BY	DOC. TYPE	MATERIAL	QUANTITY
		Part	PVC	1
University of Warwick, DTU	OHO e.V.	LICENCE	SCALE	SHEET
		CC-BY-SA 4.0	3/1	10 /23

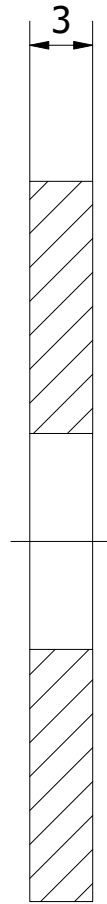

C-C (3 : 1)

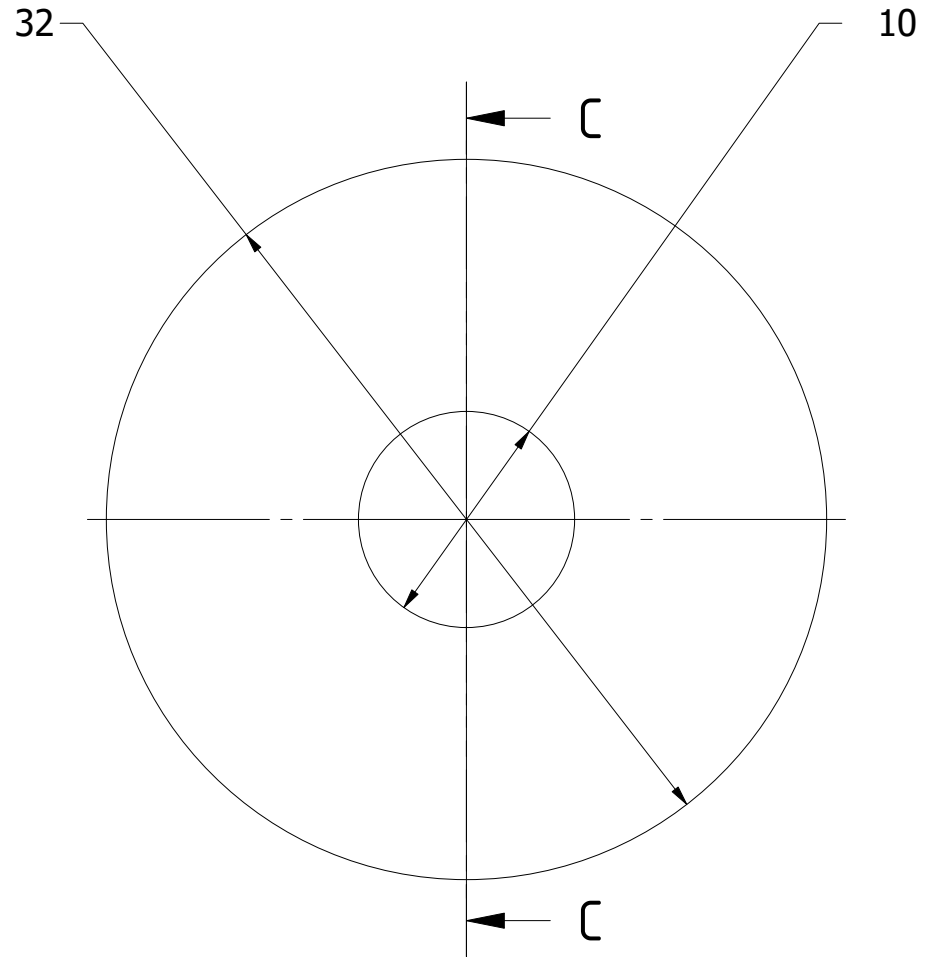

Note: All units in mm.

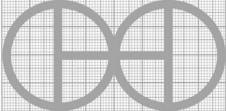
PROJECT		CREATED BY	APPROVED BY	DATE	VERSION
DTU Handpump		J. Rosciano	A. Morillo	17/06/2021	1.1
PART NAME		FILE NAME			POS
Washer 2		1.8_Washer.ipt			1.8
DEVELOPED BY		REDESIGNED BY	DOC. TYPE	MATERIAL	QUANTITY
University of Warwick, DTU			Part	PVC	1
			LICENCE	SCALE	SHEET
OH O e.V.		CC-BY-SA 4.0	3/1	11 /23	

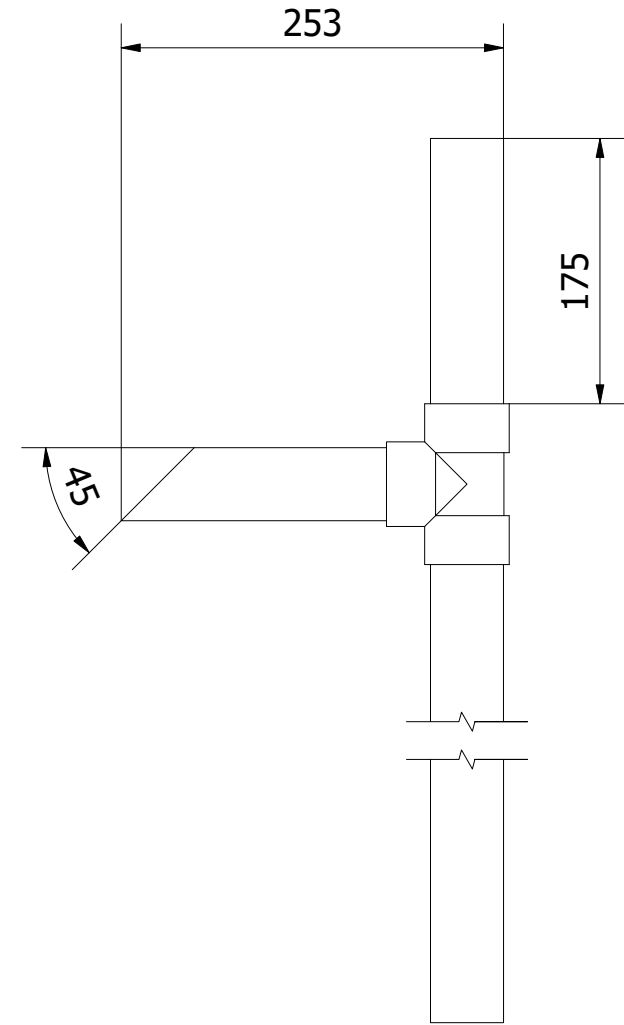
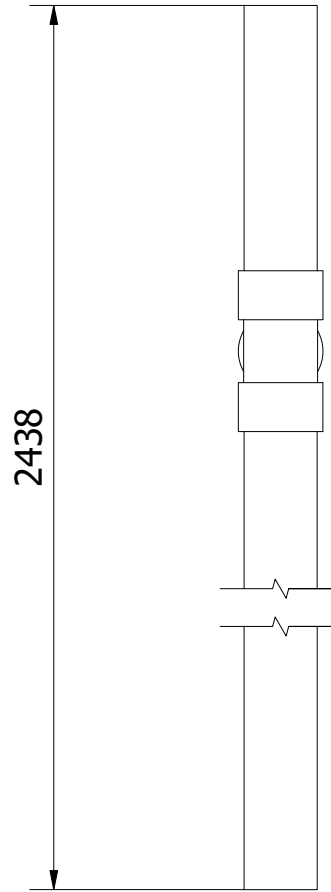
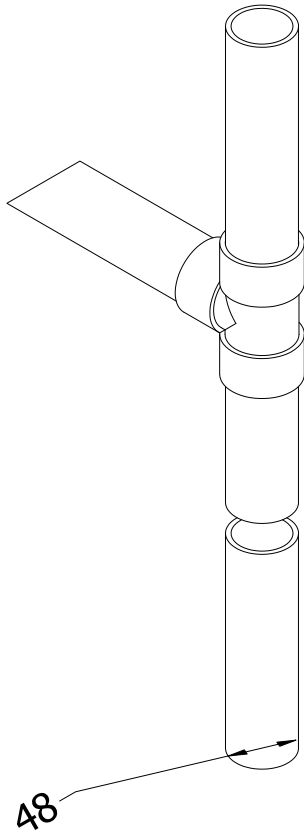

Note: All units in mm.

PROJECT	CREATED BY	APPROVED BY	DATE	VERSION
DTU Handpump	J. Rosciano	A. Morillo	17/06/2021	1.1
PART NAME	FILE NAME			POS
External assembly	2.0_External.iam			2.0
DEVELOPED BY	REDESIGNED BY	DOC. TYPE	MATERIAL	QUANTITY
		Assembly		1
University of Warwick, DTU	OHO e.V.	LICENCE	SCALE	SHEET
		CC-BY-SA 4.0	1/5	12 /23

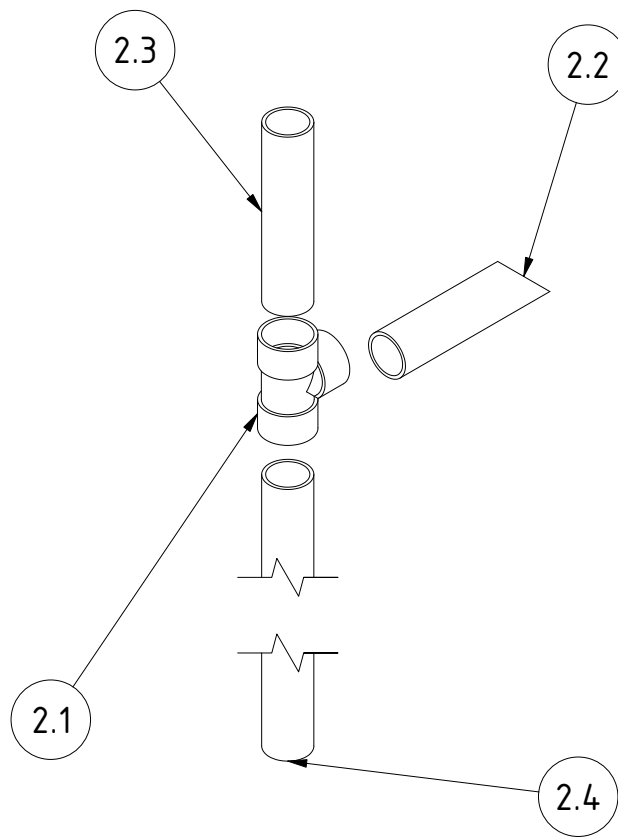

Note: All units in mm.

PROJECT	CREATED BY	APPROVED BY	DATE	VERSION
DTU Handpump	J. Rosciano	A. Morillo	17/06/2021	1.1
PART NAME	FILE NAME			POS
External assembly	2.0_External.ipn			2.0
DEVELOPED BY	REDESIGNED BY	DOC. TYPE	MATERIAL	QUANTITY
		Assembly		1
		LICENCE	SCALE	SHEET
University of Warwick, DTU OHO e.V.		CC-BY-SA 4.0	1/7	13 /23

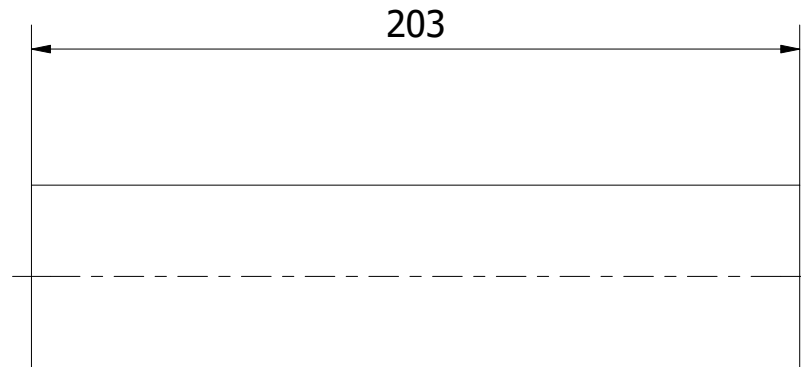
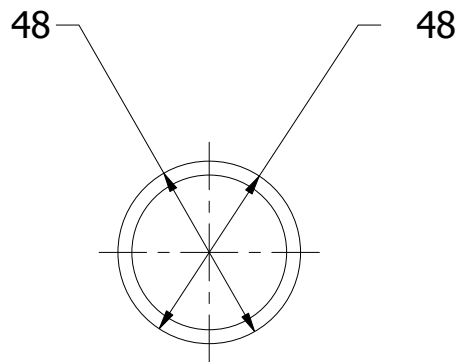

Note: All units in mm.

PROJECT	CREATED BY	APPROVED BY	DATE	VERSION
DTU Handpump	J. Rosciano	A. Morillo	17/06/2021	1.1
PART NAME	FILE NAME			POS
Top tube	2.1_Top_Tube.ipt			2.1
DEVELOPED BY	REDESIGNED BY	DOC. TYPE	MATERIAL	QUANTITY
		Part	PVC	1
		LICENCE	SCALE	SHEET
University of Warwick, DTU	OHO e.V.	CC-BY-SA 4.0	2/1	14 /23

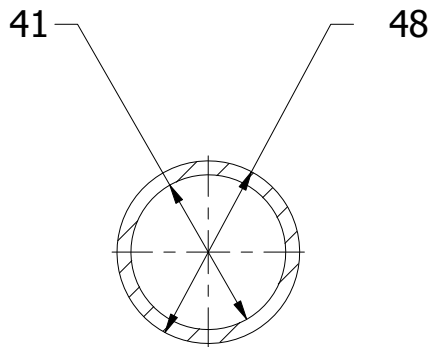

D-D (1 : 2)

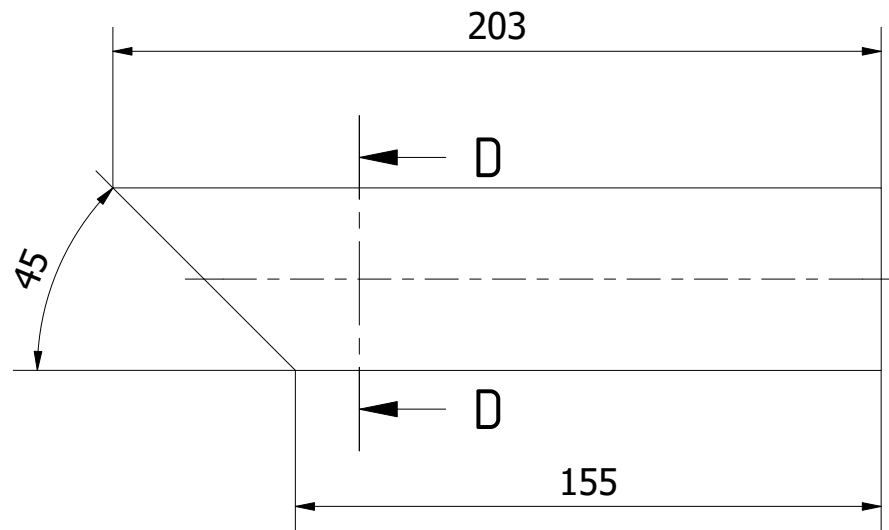

Note: All units in mm.

PROJECT	CREATED BY	APPROVED BY	DATE	VERSION
DTU Handpump	J. Rosciano	A. Morillo	17/06/2021	1.1
PART NAME	FILE NAME			POS
Outlet	2.3_Outlet.ipt			2.3
DEVELOPED BY	REDESIGNED BY	DOC. TYPE	MATERIAL	QUANTITY
		Part	PVC	1
		LICENCE	SCALE	SHEET
University of Warwick, DTU	OHO e.V.	CC-BY-SA 4.0	1/2	15 /23

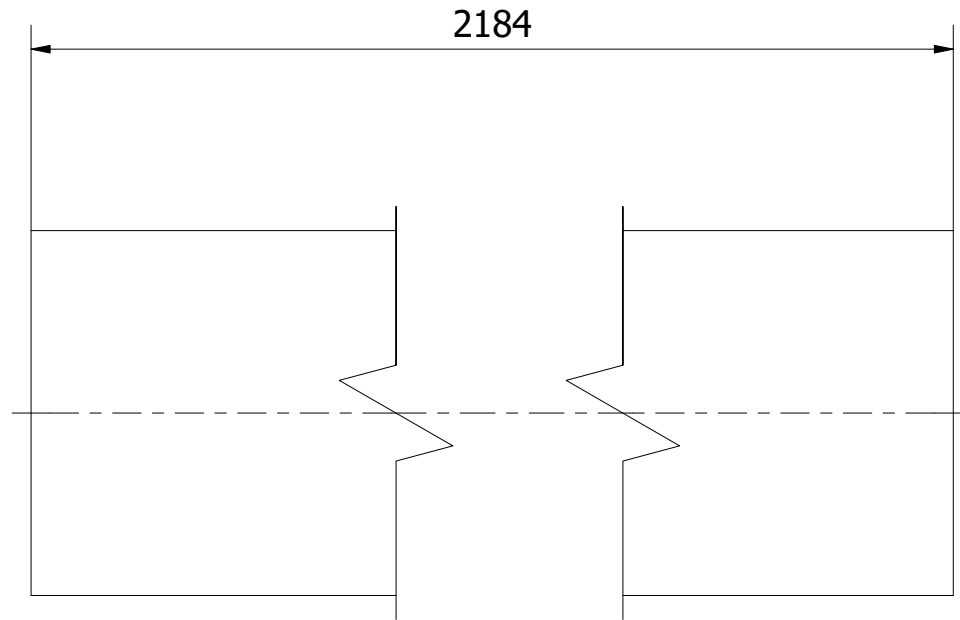
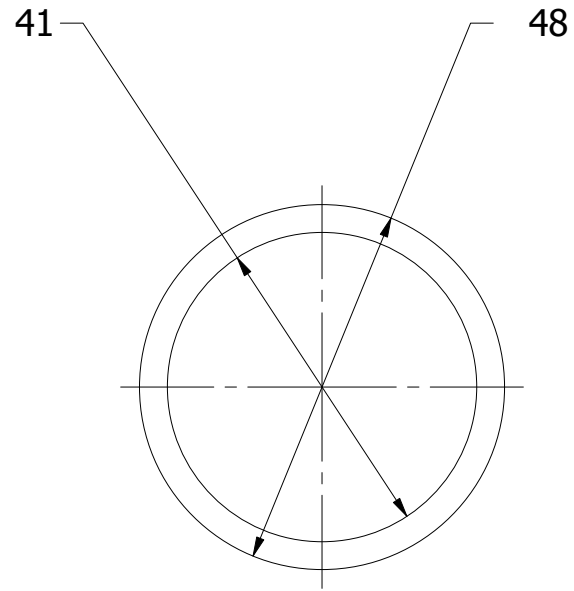

Note: All units in mm.

PROJECT	CREATED BY	APPROVED BY	DATE	VERSION
DTU Handpump	J. Rosciano	A. Morillo	17/06/2021	1.1
PART NAME	FILE NAME			POS
Rising main	2.4_Rising_Main.ipt			2.4
DEVELOPED BY	REDESIGNED BY	DOC. TYPE	MATERIAL	QUANTITY
		Part	PVC	1
		LICENCE	SCALE	SHEET
University of Warwick, DTU	OHO e.V.	CC-BY-SA 4.0	1/1	16 /23

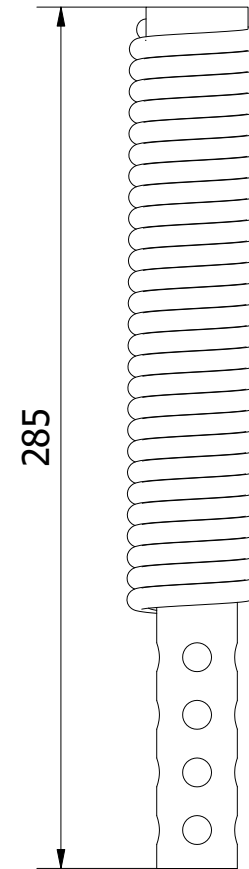
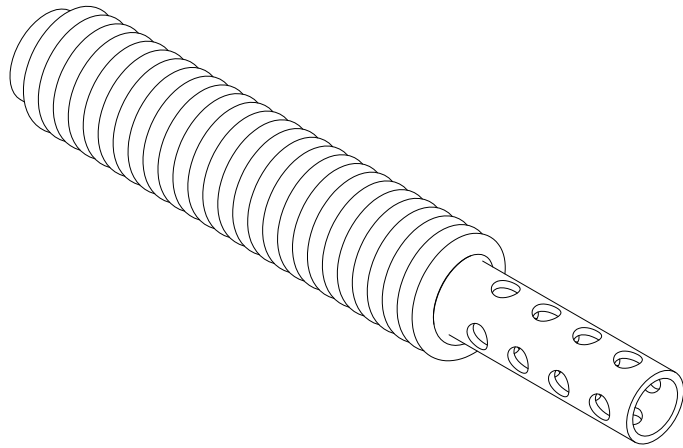

Note: All units in mm.

PROJECT	CREATED BY	APPROVED BY	DATE	VERSION
DTU Handpump	J. Rosciano	A. Morillo	17/06/2021	1.1
PART NAME	FILE NAME			POS
Valve	3.0_Valve.iam			3.0
DEVELOPED BY	REDESIGNED BY	DOC. TYPE	MATERIAL	QUANTITY
		Assembly		1
		LICENCE	SCALE	SHEET
University of Warwick, DTU	OHO e.V.	CC-BY-SA 4.0	1/2	17 /23

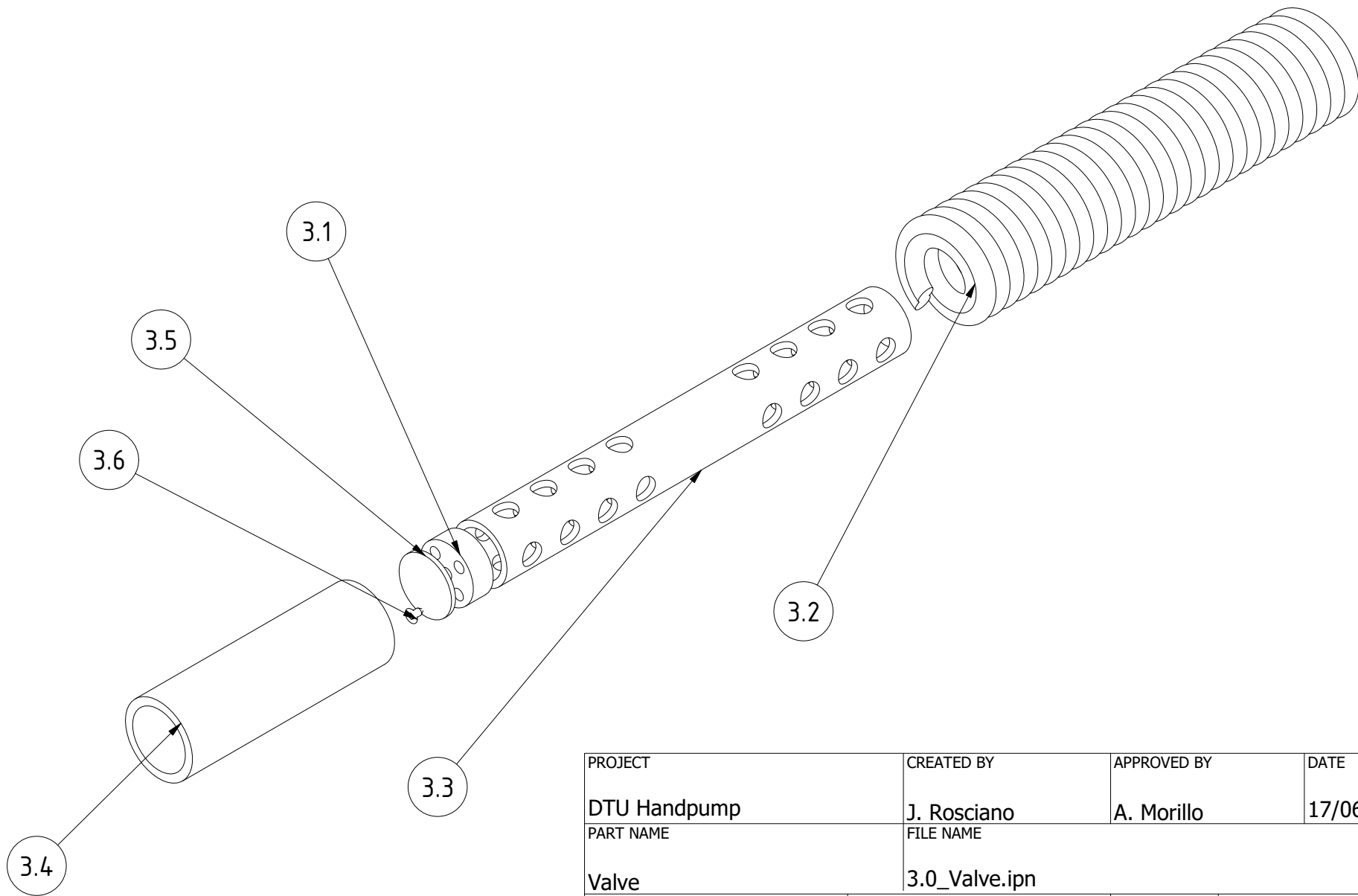

PROJECT	CREATED BY	APPROVED BY	DATE	VERSION
DTU Handpump	J. Rosciano	A. Morillo	17/06/2021	1.1
PART NAME	FILE NAME			POS
Valve	3.0_Valve.ipn			3.0
DEVELOPED BY	REDESIGNED BY	DOC. TYPE	MATERIAL	QUANTITY
		Assembly		1
University of Warwick, DTU	OHO e.V.	LICENCE	SCALE	SHEET
		CC-BY-SA 4.0	1/3	18 /23

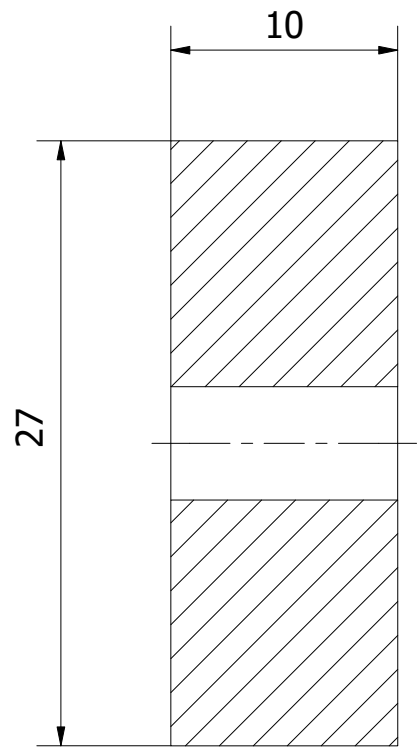

F-F (3/1)

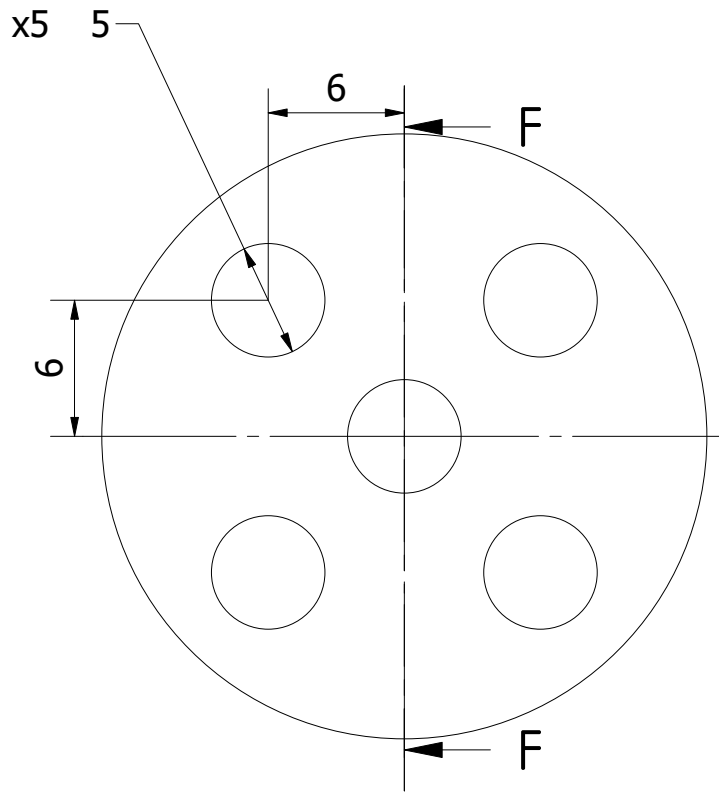

Note: All units in mm.

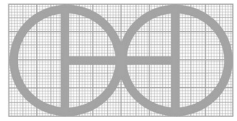
PROJECT	CREATED BY	APPROVED BY	DATE	VERSION
DTU Handpump	J. Rosciano	A. Morillo	17/06/2021	1.1
PART NAME	FILE NAME			POS
Piece of wood	3.1_Piece_Of_Wood.ipt			3.1
DEVELOPED BY	REDESIGNED BY	DOC. TYPE	MATERIAL	QUANTITY
		Part	Hardwood	1
		LICENCE	SCALE	SHEET
University of Warwick, DTU	OHO e.V.	CC-BY-SA 4.0	1/1	19 /23

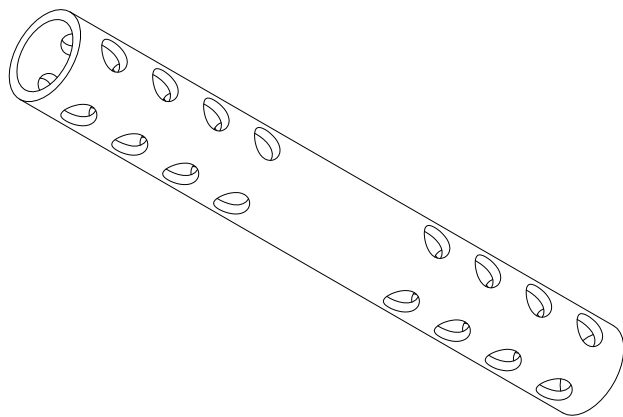
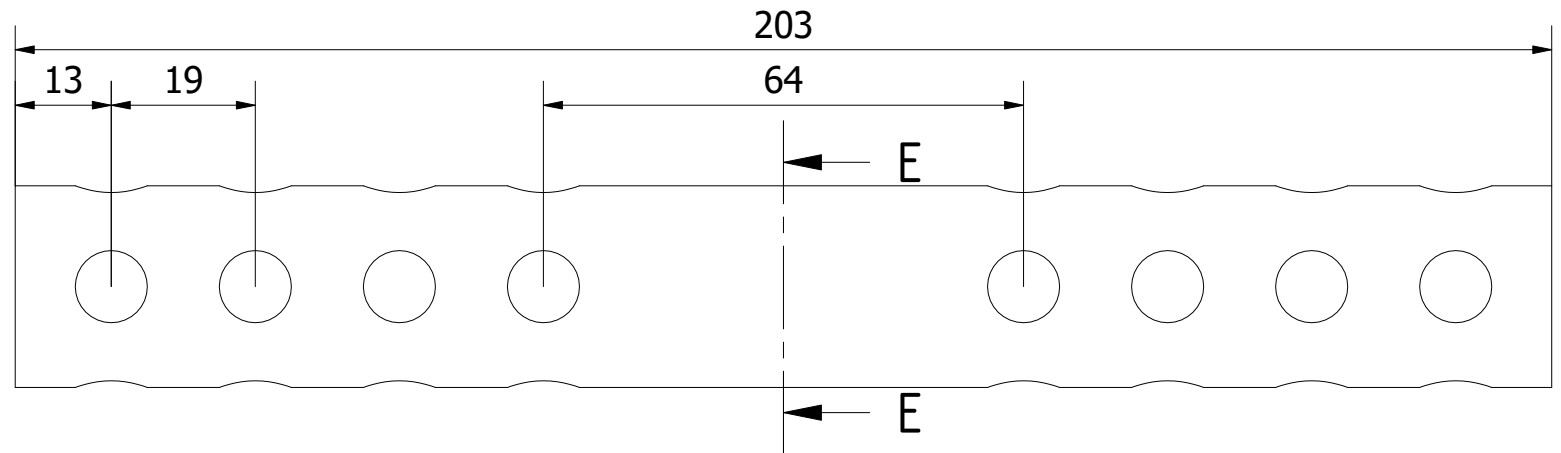
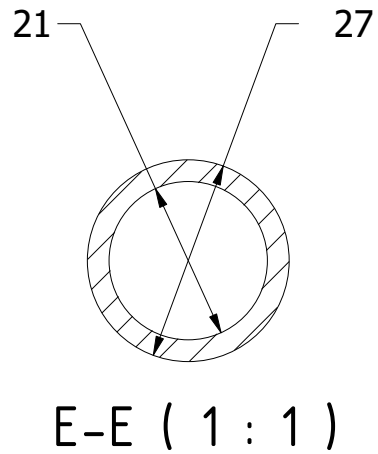

Note: All units in mm.

PROJECT	CREATED BY	APPROVED BY	DATE	VERSION
DTU Handpump	J. Rosciano	A. Morillo	17/06/2021	1.1
PART NAME	FILE NAME			POS
Perforated tube	3.3_Peforated_Tube.ipt			3.3
DEVELOPED BY	REDESIGNED BY	DOC. TYPE	MATERIAL	QUANTITY
		Part	PVC	1
		LICENCE	SCALE	SHEET
University of Warwick, DTU	OHO e.V.	CC-BY-SA 4.0	1/1	20 /23

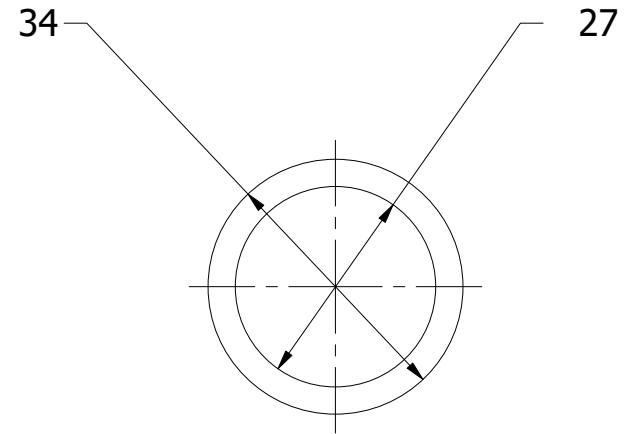
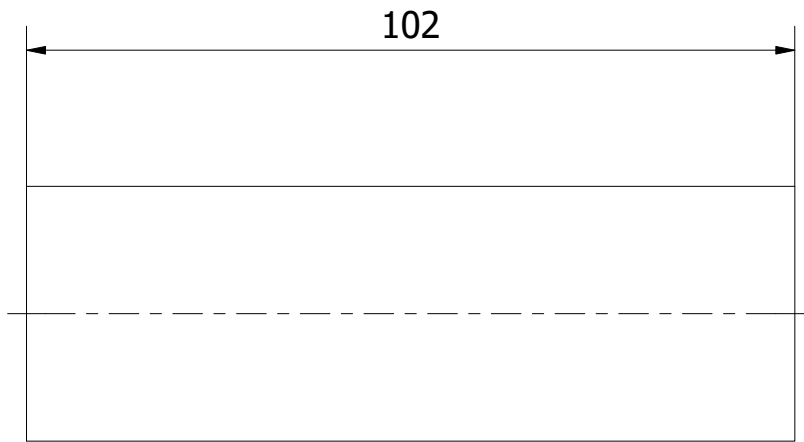

Note: All units in mm.

PROJECT	CREATED BY	APPROVED BY	DATE	VERSION
DTU Handpump	J. Rosciano	A. Morillo	17/06/2021	1.1
PART NAME	FILE NAME			POS
Bicycle tube	3.4_Bicycle_Tube.ipt			3.4
DEVELOPED BY	REDESIGNED BY	DOC. TYPE	MATERIAL	QUANTITY
		Part	ASTM A36	1
		LICENCE	SCALE	SHEET
University of Warwick, DTU	OHO e.V.	CC-BY-SA 4.0	1/1	21 /23

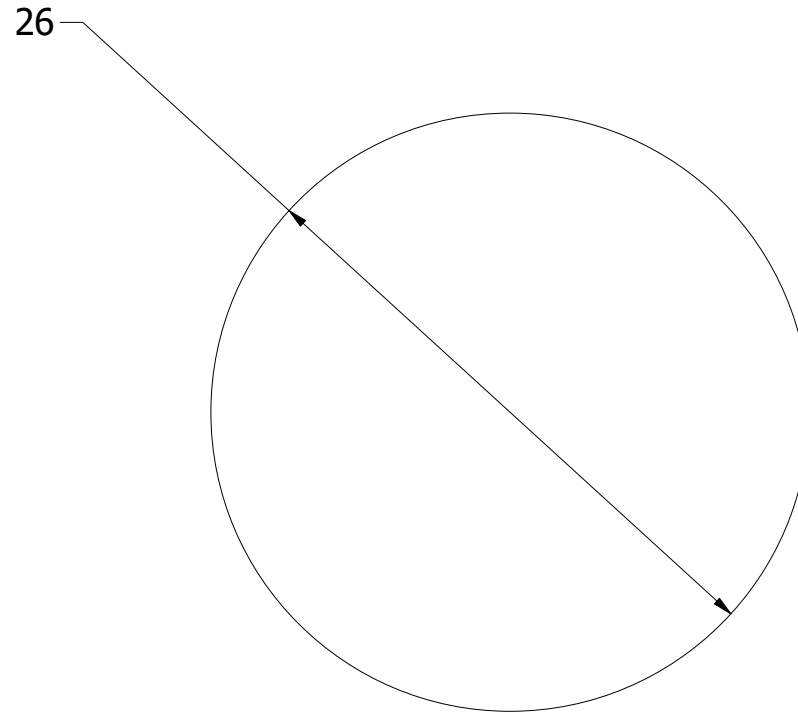
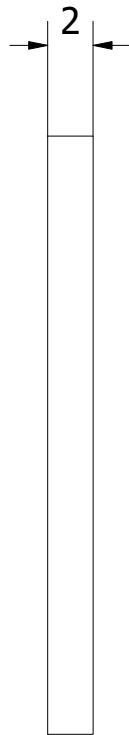

Note: All units in mm.

PROJECT	CREATED BY	APPROVED BY	DATE	VERSION
DTU Handpump	J. Rosciano	A. Morillo	17/06/2021	1.1
PART NAME	FILE NAME			POS
Rubber	3.5_Rubber.ipt			3.5
DEVELOPED BY	REDESIGNED BY	DOC. TYPE	MATERIAL	QUANTITY
		Part	Rubber	1
		LICENCE	SCALE	SHEET
University of Warwick, DTU	OHO e.V.	CC-BY-SA 4.0	3/1	22 /23

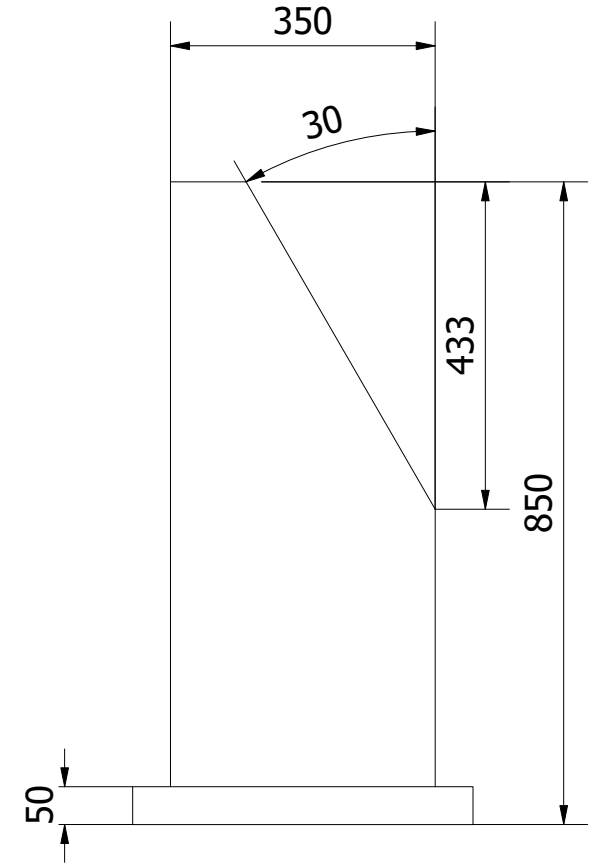
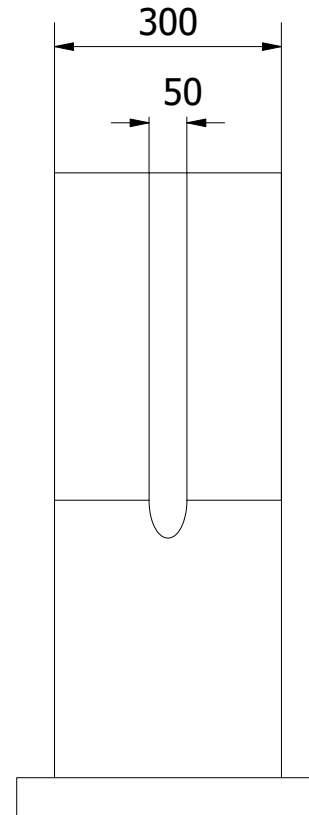
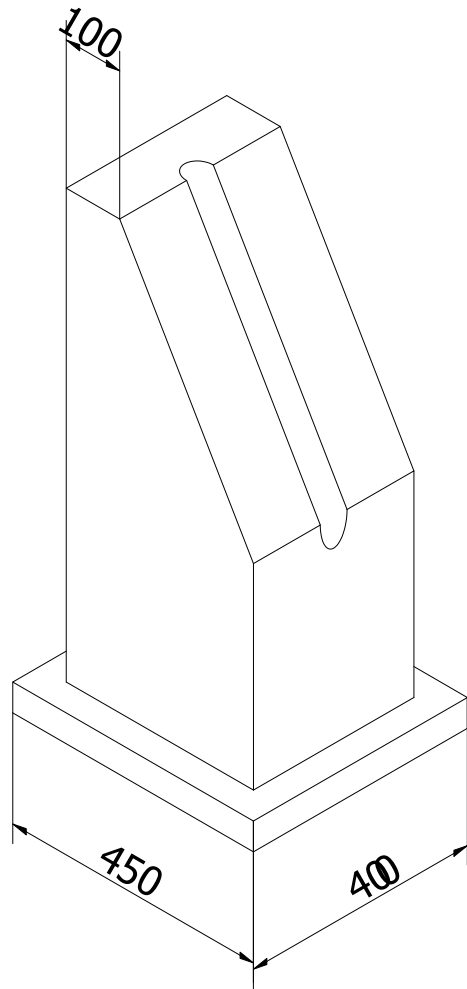

Note: All units in mm.

PROJECT	CREATED BY	APPROVED BY	DATE	VERSION
DTU Handpump	J. Rosciano	A. Morillo	17/06/2021	1.1
PART NAME	FILE NAME			POS
Concrete support	4.0_Concrete_Support.ipt			4.0
DEVELOPED BY	REDESIGNED BY	DOC. TYPE	MATERIAL	QUANTITY
		Part	Concrete	1
University of Warwick, DTU OHO e.V.		LICENCE	SCALE	SHEET
		CC-BY-SA 4.0	1/10	23 /23