

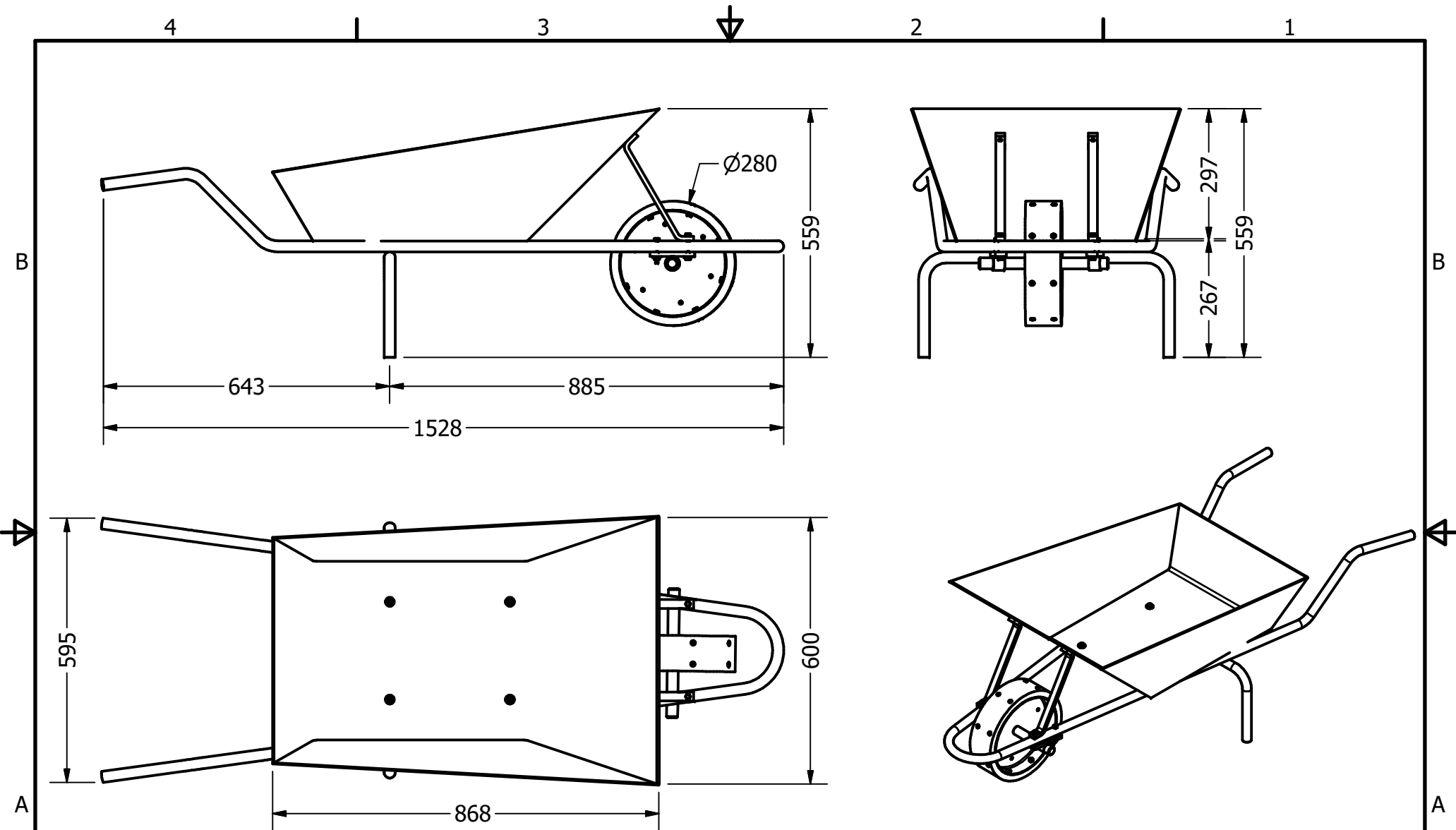





PROJEKT Schubkarre		ERSTELLT VON D. Mosquera	GENEHMIGT VON D. Jeager		
TEIL-NAME Schubkarre		TEIL-CODE A1	DOKUMENTTYP ASSEMBLY	WERKSTOFF	
UMGESTALTET VON  Open Source Ecology e.V. Knobelsdorffstr. 22 14059 Berlin www.ose-germany.de +49 (0) 30 / 92282426	Originalzeichnung aus Practical ACTION	LIZENZ CERN-OHL	TEIL-NAME oseg_wb_A1_wheel-barrow.iam	VERSION 1.0	MENGE
			SCALE 1:8	SEITE 1	DATE 11.11.20

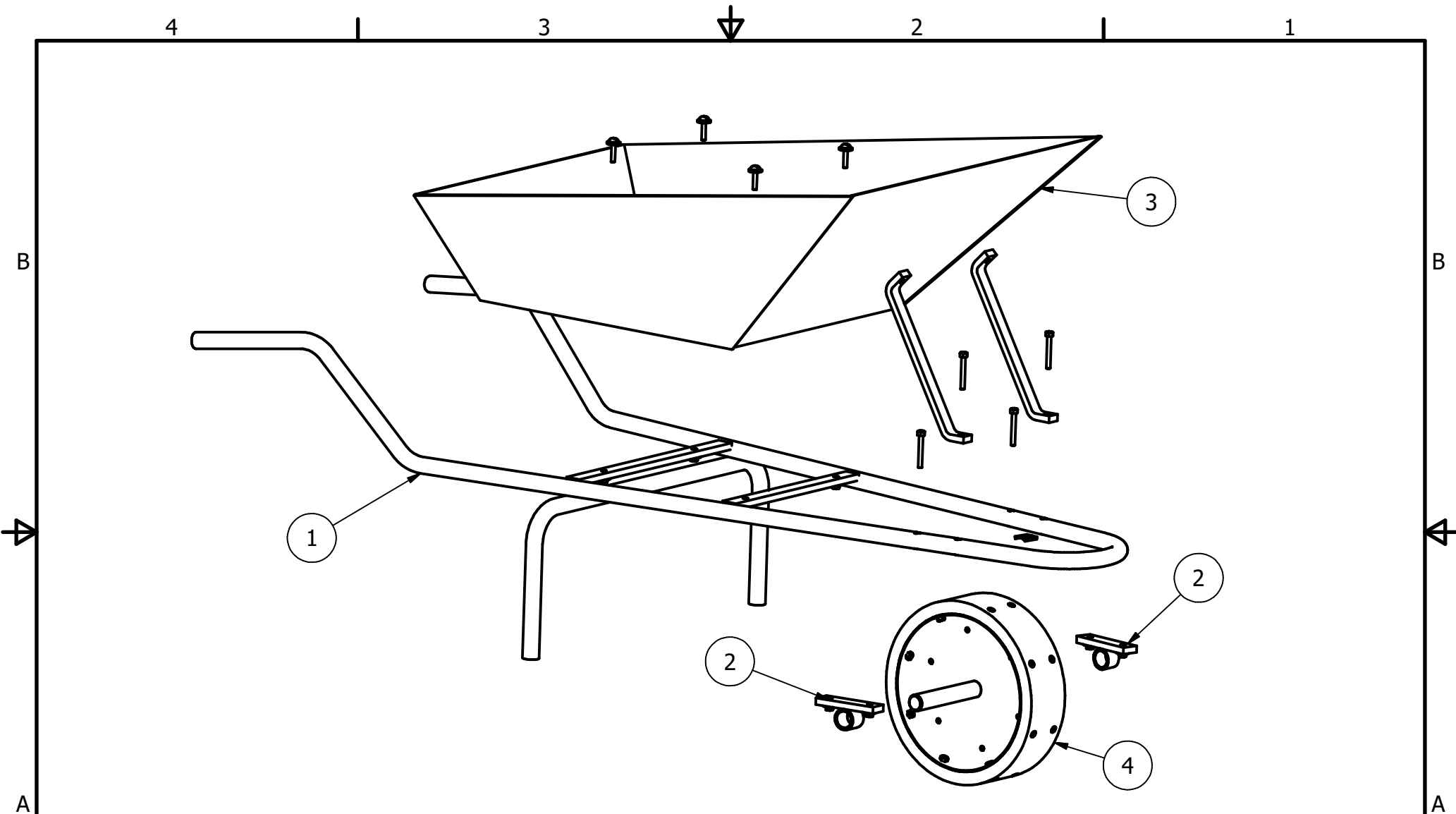

PROJEKT Schubkarre		ERSTELLT VON D. Mosquera		GENEHMIGT VON D. Jeager	
TEIL-NAME Schubkarre		TEIL-CODE A2		DOKUMENTTYP ASSEMBLY	
UMGESTALTET VON  Open Source Ecology e.V. Knobelsdorffstr. 22 14059 Berlin www.ose-germany.de +49 (0) 30 / 92282426		Originalzeichnung aus Practical ACTION		LIZENZ CERN-OHL	
				TEIL-NAME oseg_wb_A1_wheel-barrow.iam	
				SCALE 1:12	
				VERSION 1.0	
				MENGE	
				SEITE 2	
				DATE 11.11.20	



PROJEKT Schubkarre		ERSTELLT VON D. Mosquera		GENEHMIGT VON D. Jeager	
TEIL-NAME Schubkarre		TEIL-CODE A2		DOKUMENTTYP ASSEMBLY	
UMGESTALTET VON		Originalzeichnung aus		LIZENZ	
 Open Source Ecology e.V. Knobelsdorffstr. 22 14059 Berlin www.ose-germany.de +49 (0) 30 / 92282426				CERN-OHL	
 OPEN SOURCE ECOLOGY GERMANY				TEIL-NAME oseg_wb_A1_wheel-barrow.ipn	
				SCALE 1:8	
				SEITE 3	
				DATE 11.11.20	

4

3

2

1

Parts list

POS	Pos. old	QTY	TEIL NAME	DATEI-NAME	TEIL-TYP	SPEZIFIKATIONEN	SEITE
A1			Schubkarre	oseg_wb_A1_wheel-barrow.iam	production		1
B			Schubkarre Teile-Liste	oseg_wb_B_parts-list.			4
1	1	1	Fahrgestell	oseg_wb_1_chassis.iam			5
1.1	3	1	Aufbau Fahrgestell	oseg_wb_1.1_structure-chassis.ipt	production		6
1.2		1	Stützbeine	oseg_wb_1.2_support-legs.ipt	production		7
1.3	6	1	Stützbeine	oseg_wb_1.3_rear-mounting-braket.ipt	production		8
1.4	7	1	Vordere Befestigungsbremse	oseg_wb_1.4_front-mounting-braket.ipt	production		9
1.5	4	2	Vorderradbremse	oseg_wb_1.5_front-braket.ipt	production		10
1.6	5	4	Verstärkungsbein	oseg_wb_1.6_reinforcement-leg.ipt	production		11
2	8	2	Achslagerkonsole	oseg_wb_2_Axle-bearing-bracket.iam			12
2.1		2	Lager	oseg_wb_2.1_bearing.ipt	production		14
2.2		2	Klammern	oseg_wb_2.2_brackets.ipt	production		15
3	2	1	Trichter	oseg_wb_3_hopper.iam			16
3.1		1	Trichterblech	oseg_wb_3.1_hopper-sheet.iam	production		18
3.2		2	Trichterseite	oseg_wb_3.2_hopper-side.iam	production		19
3.3		4	Schraube Sechskantkopf		Standard	ISO- M6 x 30	
3.4		4	Sechskantmutter		Standard	Heavy Hex Nut Metric M6x1.75	
3.5		4	Glatte Unterlegscheiben		Standard	ISO -ST 6-140 HV	
4	9	1	Rad	oseg_wb_4_Wheel.iam	Assembly		20
4.1		1	Achse	oseg_wb_4.1_axis.ipt	production		2
4.2		2	Radarmatur	oseg_wb_4.2_wheel-armature.ipt	production		23
4.3		1	Streifen eines Reifens	oseg_wb_4.3_strip-of-tyre.ipt	production		24
4.4		12	Schraube Inbuskopf		Standard	ISO- M6 x 30	
4.5		12	Sechskantmutter		Standard	Heavy Hex Nut Metric M6x1.75	
4.6		12	Glatte Unterlegscheiben		Standard	ISO -ST 6-140 HV	

PROJEKT Schubkarre		ERSTELLT VON D. Mosquera	GENEHMIGT VON D. Jeager		
TEIL-NAME Schubkarre Teile-Liste		TEIL-CODE B1	DOKUMENTTYP Part list		WERKSTOFF
UMGESTALTET VON  Open Source Ecology e.V. Knobelsdorffstr. 22 14059 Berlin www.ose-germany.de +49 (0) 30 / 92282426	Originalzeichnung aus Practical ACTION	LIZENZ CERN-OHL	TEIL-NAME oseg_wb_A1_wheel-barrow.iam	VERSION 1.0	MENGE
			SCALE S/E	SEITE 4	DATE 11.11.20

4

3

2

1

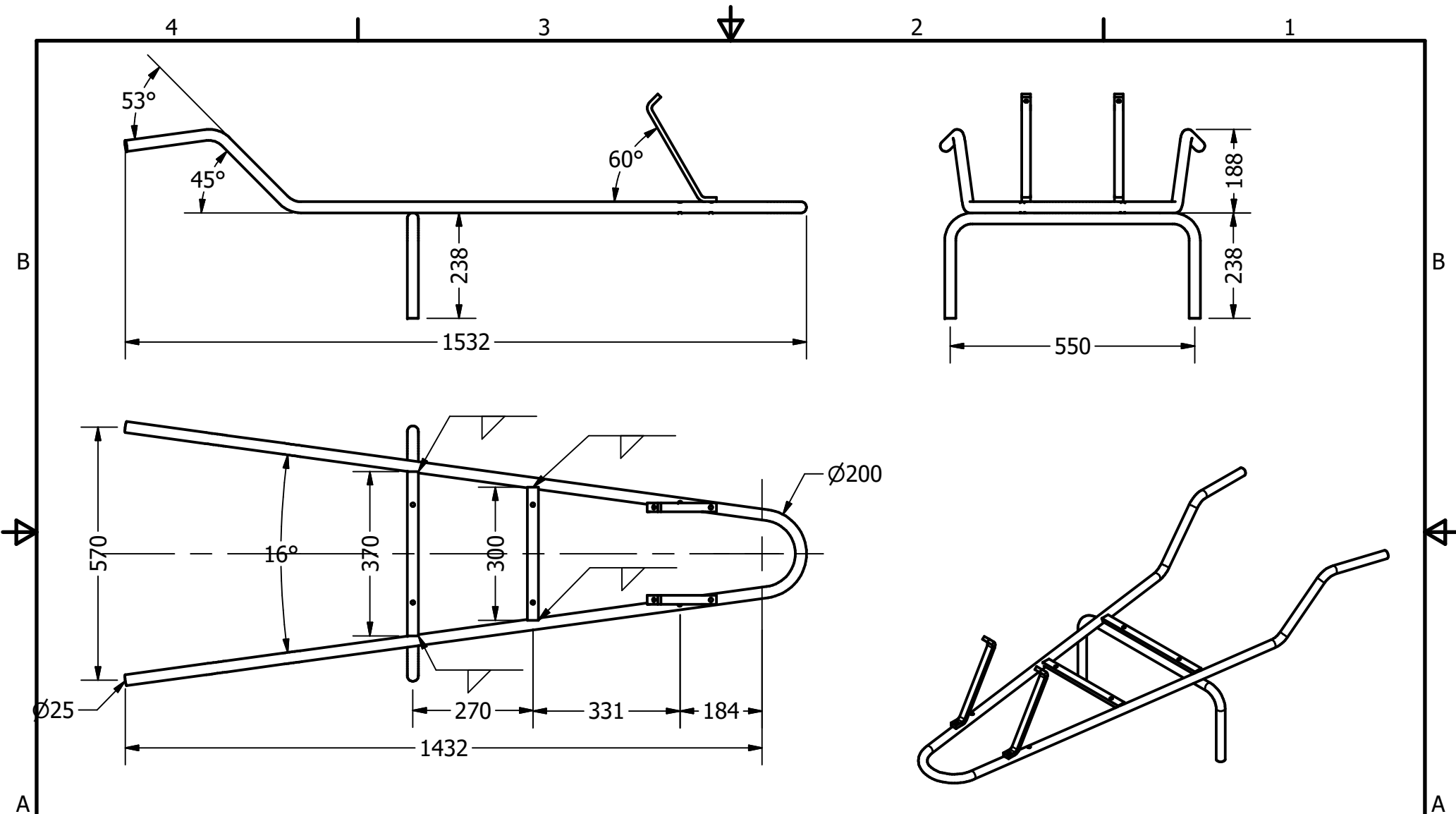

PROJEKT Schubkarre		ERSTELLT VON D. Mosquera		GENEHMIGT VON D. Jeager		
TEIL-NAME Fahrgestell		TEIL-CODE 1		DOKUMENTTYP ASSEMBLY		WERKSTOFF
UMGESTALTET VON  Open Source Ecology e.V. Knobelsdorffstr. 22 14059 Berlin www.ose-germany.de +49 (0) 30 / 92282426		Originalzeichnung aus Practical ACTION		LIZENZ CERN-OHL		TEIL-NAME oseg_wb_1_chassis.iam
				SCALE 1:12		VERSION 1.0
						MENGE 1
						DATE 11.11.20
						SEITE 5

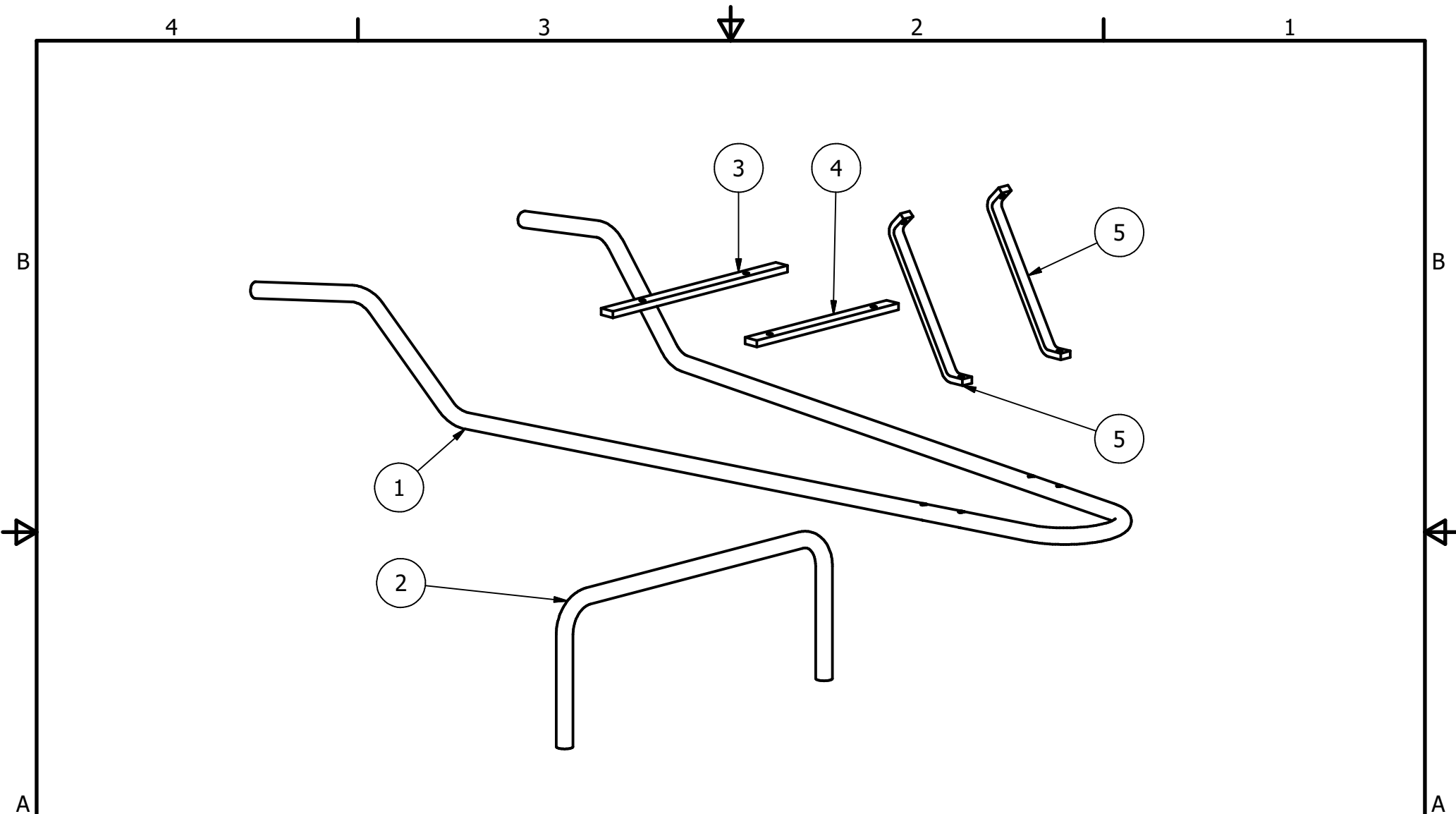

PROJEKT Schubkarre		ERSTELLT VON D. Mosquera	GENEHMIGT VON D. Jeager			
TEIL-NAME Fahrgestell		TEIL-CODE 1	DOKUMENTTYP ASSEMBLY	WERKSTOFF		
UMGESTALTET VON	 Open Source Ecology e.V. Knobelsdorffstr. 22 14059 Berlin www.ose-germany.de +49 (0) 30 / 92282426	Originalzeichnung aus	LIZENZ CERN-OHL	TEIL-NAME oseg_wb_1_chassis.ipn	VERSION 1.0	MENGE
		Practical ACTION		SCALE 1:12	SEITE 6	DATE 11.11.20

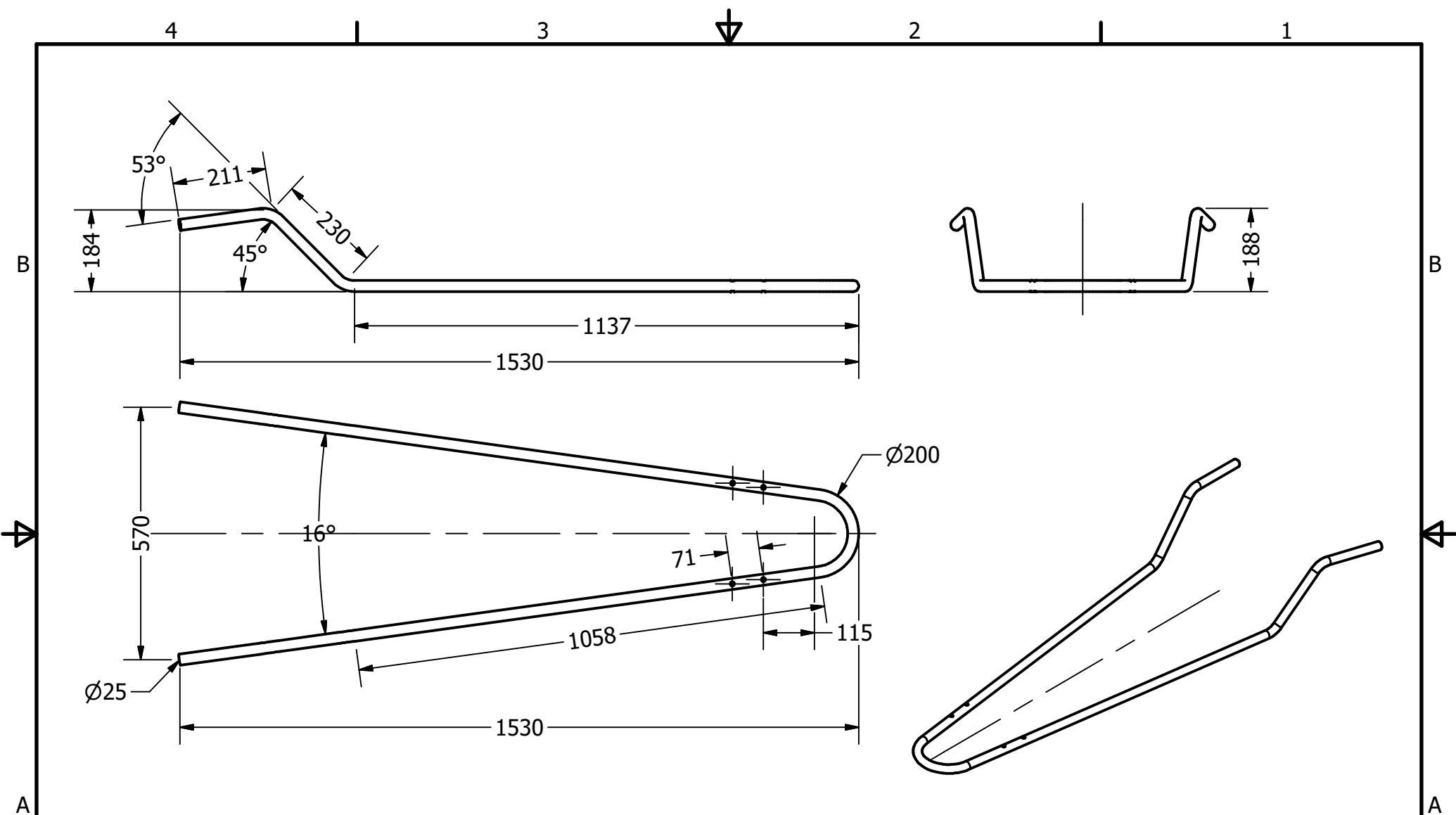

PROJEKT Schubkarren Wheel Barrow		ERSTELLT VON D. Mosquera		GENEHMIGT VON D. Jeager	
TEIL-NAME Aufbau Fahrgestell		TEIL-CODE 1.1		DOKUMENTTYP part	
UMGESTALTET VON  Open Source Ecology e.V. Knobelsdorffstr. 22 14059 Berlin www.ose-germany.de +49 (0) 30 / 92282426		Originalzeichnung aus Practical ACTION		LIZENZ CERN-OHL	
		TEIL-NAME oseg_wb_1.1_structure-chassis.ipt		VERSION 1.0	
		SCALE 1:12		MENGE 7	
				DATE 11.11.20	

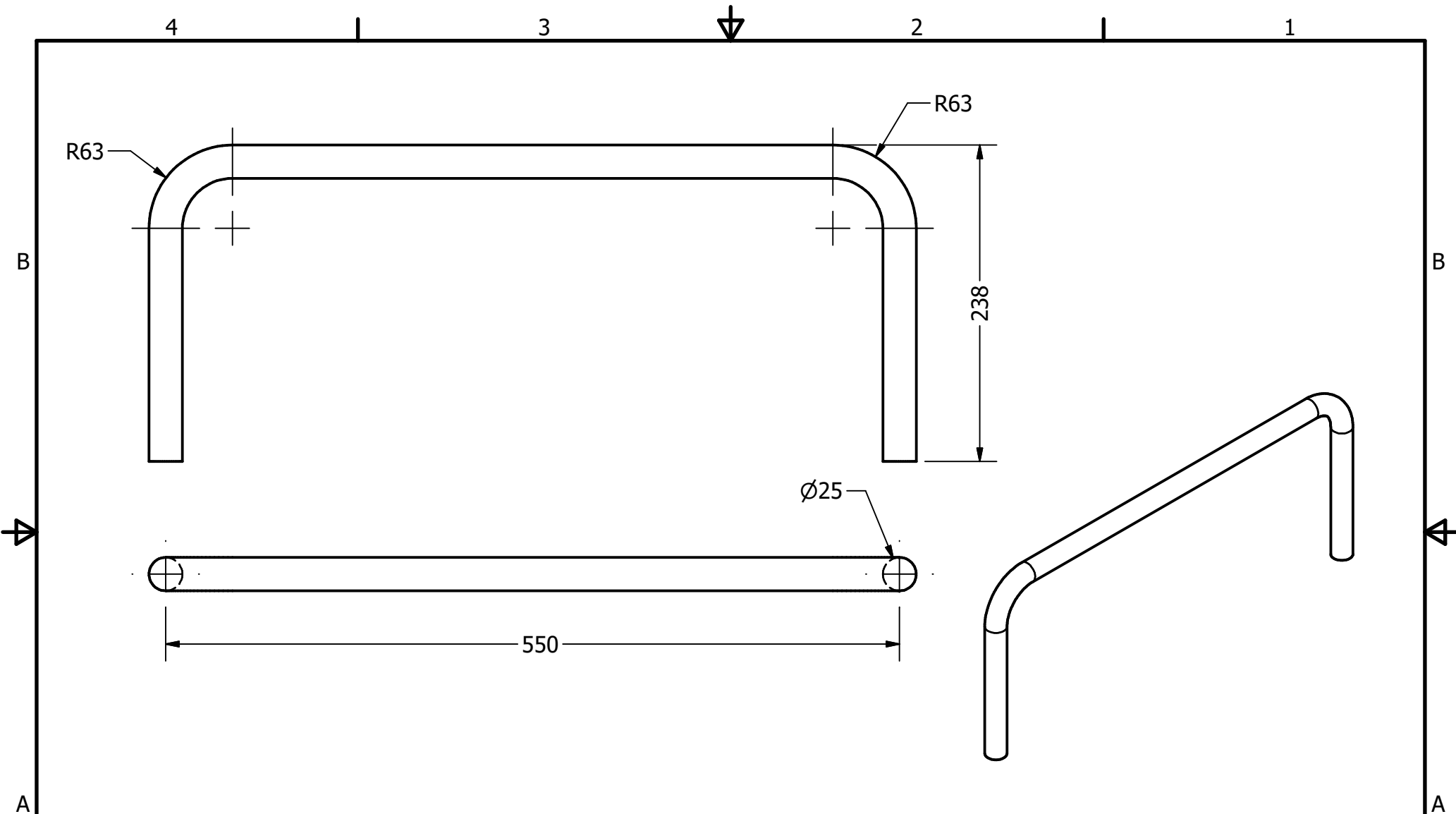

PROJEKT Schubkarre		ERSTELLT VON D. Mosquera	GENEHMIGT VON D. Jeager		
TEIL-NAME Stützbeine		TEIL-CODE 1.2	DOKUMENTTYP part	WERKSTOFF Iron, Gray	
UMGESTALTET VON  <small>OPEN SOURCE ECOLOGY GERMANY</small> Open Source Ecology e.V. Knobelsdorffstr. 22 14059 Berlin www.ose-germany.de +49 (0) 30 / 92282426	Originalzeichnung aus Practical ACTION	LIZENZ CERN-OHL	TEIL-NAME oseg_wb_1.2_support-legs.ipt	VERSION 1.0	MENGE
			SCALE 1:4	SEITE 8	DATE 11.11.20

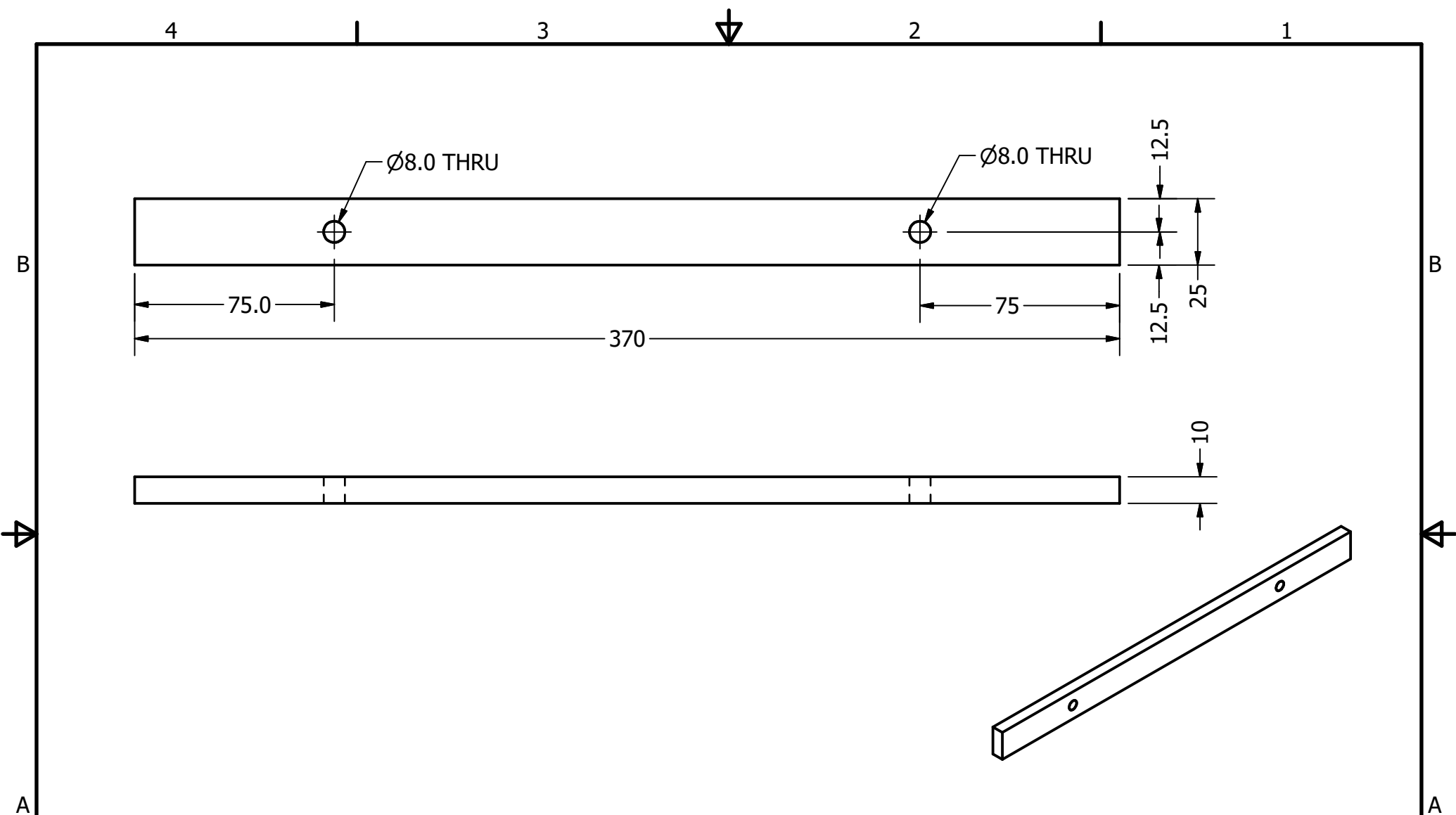

PROJEKT Schubkarre		ERSTELLT VON D. Mosquera	GENEHMIGT VON D. Jeager		
TEIL-NAME Vordere Befestigungsbremse		TEIL-CODE 1.3	DOKUMENTTYP part	WERKSTOFF Iron, Gray	
UMGESTALTET VON  Open Source Ecology e.V. Knobelsdorffstr. 22 14059 Berlin www.ose-germany.de +49 (0) 30 / 92282426	Originalzeichnung aus Practical ACTION	LIZENZ CERN-OHL	TEIL-NAME oseg_wb_1.3_rear-mounting-braket.ip	VERSION 1.0	MENGE
			SCALE 1:2	SEITE 9	DATE 11.11.20

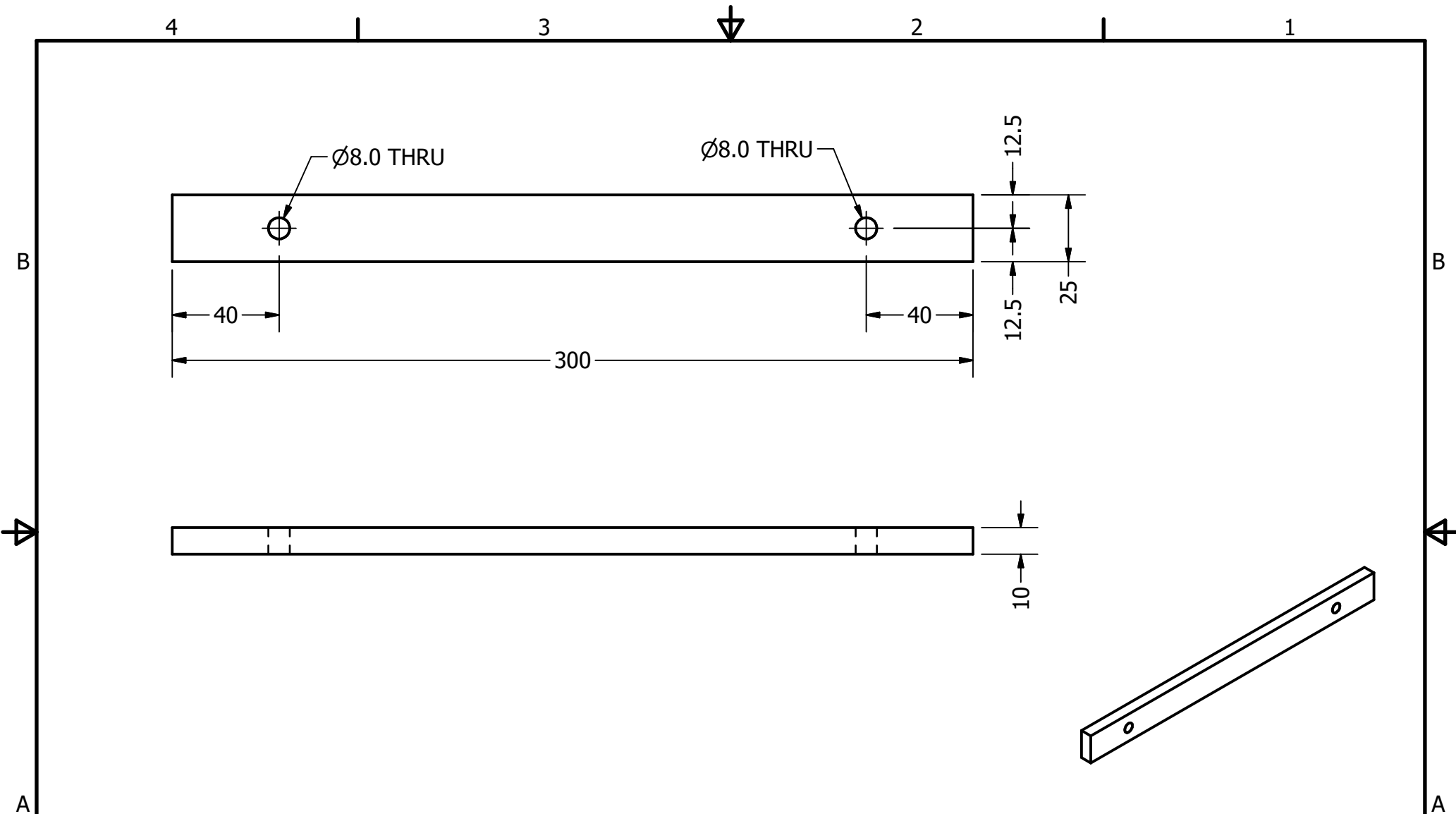

PROJEKT Schubkarre		ERSTELLT VON D. Mosquera		GENEHMIGT VON D. Jeager		
TEIL-NAME Vordere Befestigungsbremse		TEIL-CODE 1.4		DOKUMENTTYP part		WERKSTOFF Iron, Gray
UMGESTALTET VON  Open Source Ecology e.V. Knobelsdorffstr. 22 14059 Berlin www.ose-germany.de +49 (0) 30 / 92282426		Originalzeichnung aus Practical ACTION		LIZENZ CERN-OHL oseg_wb_1.4_front-mounting-braket.ip		TEIL-NAME oseg_wb_1.4_front-mounting-braket.ip
				SCALE 1:2		VERSION 1.0
						MENGE 10
						DATE 11.11.20

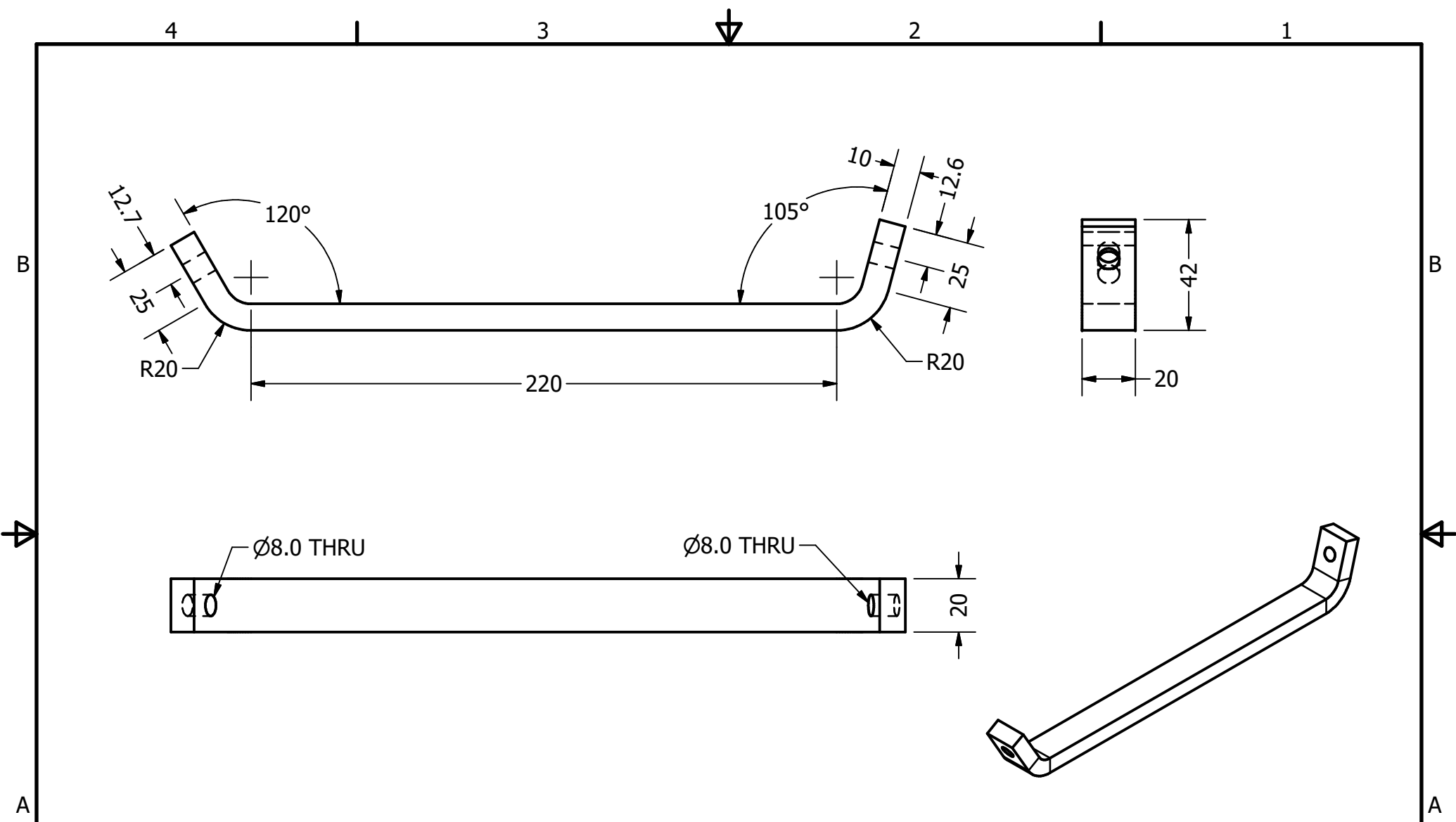

PROJEKT Schubkarre		ERSTELLT VON D. Mosquera		GENEHMIGT VON D. Jeager		
TEIL-NAME Vorderradbremse		TEIL-CODE 1.5		DOKUMENTTYP part		WERKSTOFF Iron, Gray
UMGESTALTET VON  Open Source Ecology e.V. Knobelsdorffstr. 22 14059 Berlin www.ose-germany.de +49 (0) 30 / 92282426		Originalzeichnung aus Practical ACTION		LIZENZ CERN-OHL		TEIL-NAME oseg_wb_1.5_front-braket.ipt
				SCALE 1:2		VERSION 1.0
						MENGE 11
						DATE 11.11.20

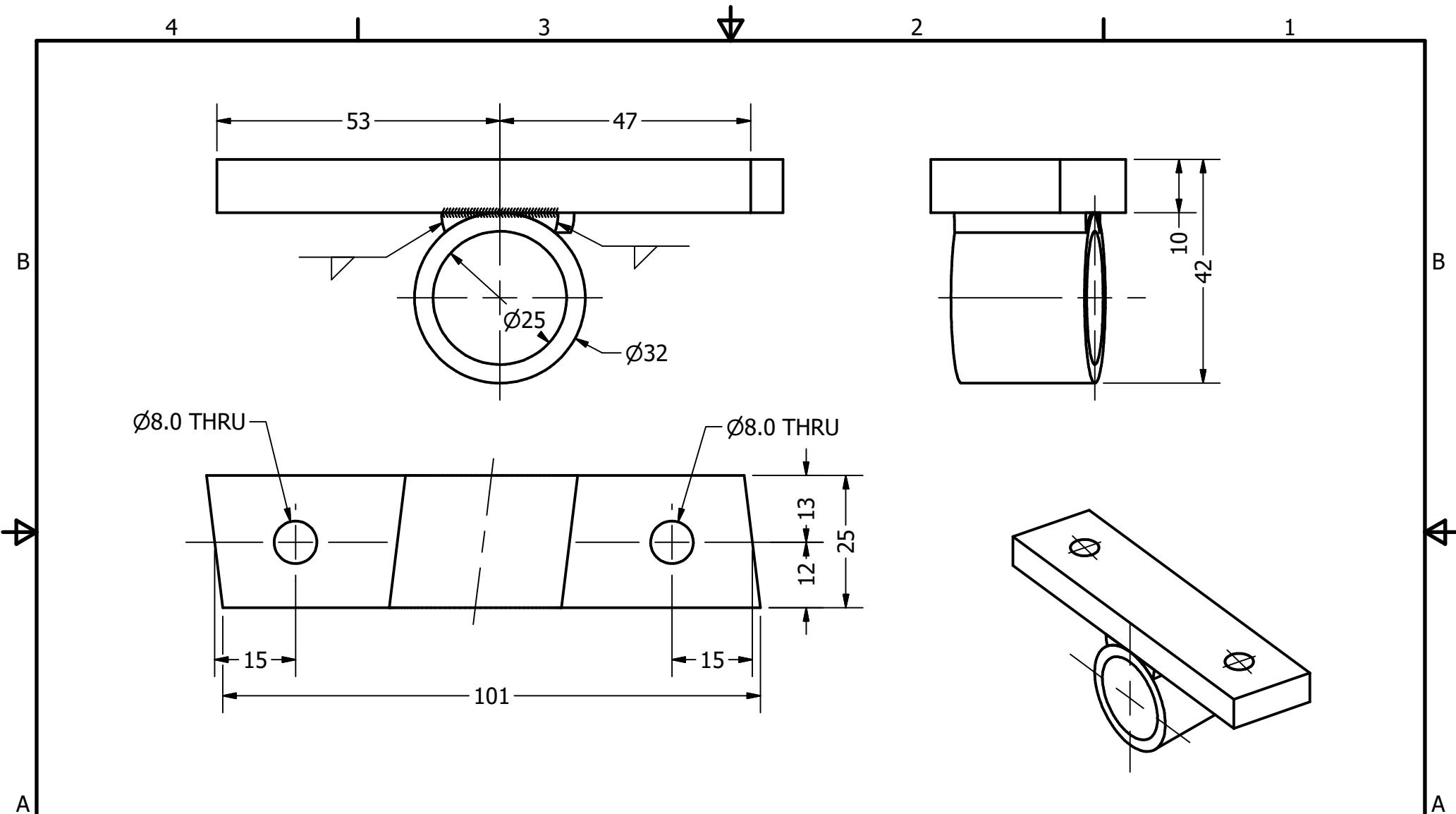

PROJEKT Schubkarre		ERSTELLT VON D. Mosquera	GENEHMIGT VON D. Jeager		
TEIL-NAME Achslagerkonsole		TEIL-CODE 2	DOKUMENTTYP Assambly		WERKSTOFF
UMGESTALTET VON  Open Source Ecology e.V. Knobelsdorffstr. 22 14059 Berlin www.ose-germany.de +49 (0) 30 / 92282426	Originalzeichnung aus Practical ACTION	LIZENZ CERN-OHL	TEIL-NAME oseg_wb_2_Axle-bearing-bracket.am	VERSION 1.0	MENGE
			SCALE 1:1	SEITE 12	DATE 11.11.20

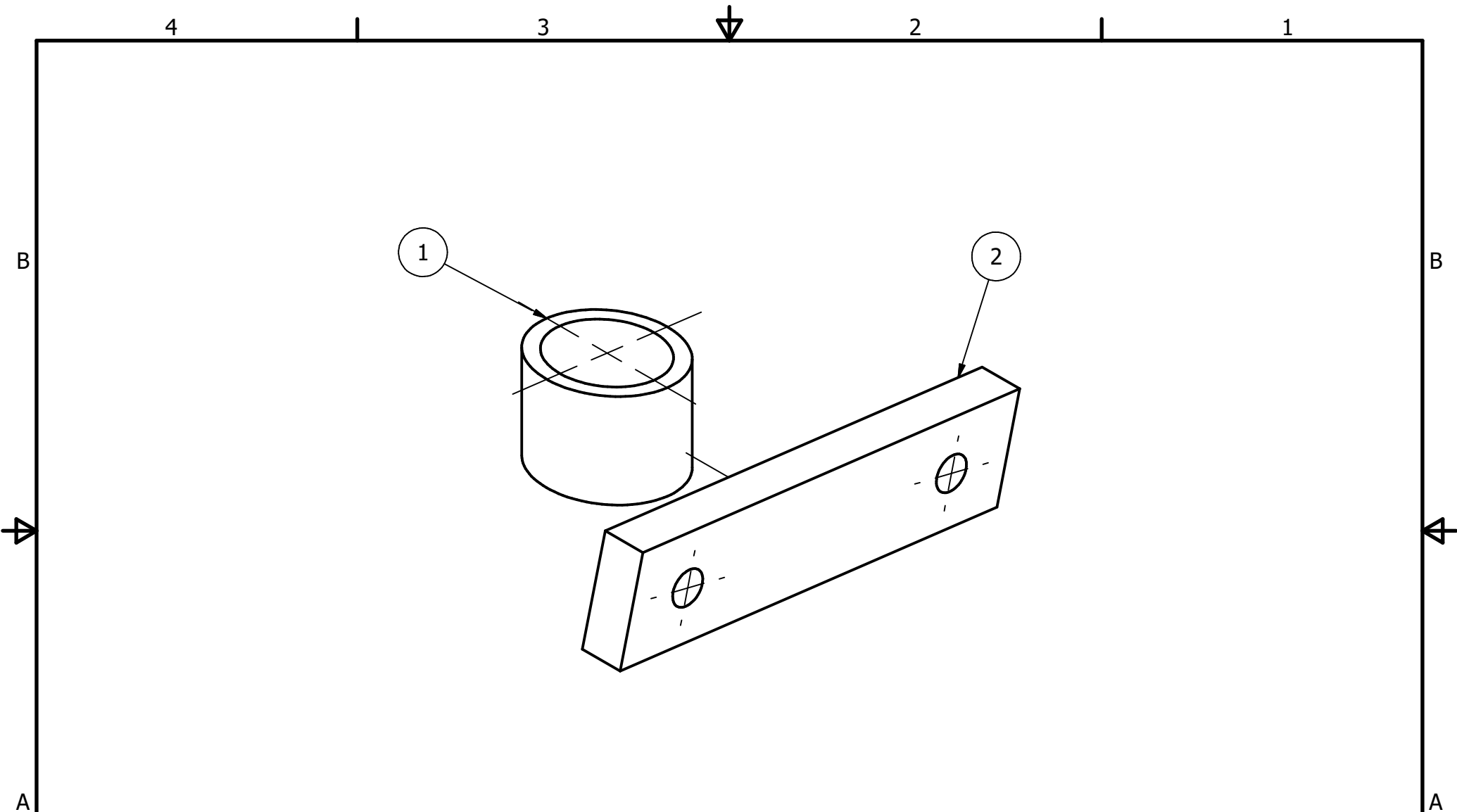

PROJEKT Schubkarre		ERSTELLT VON D. Mosquera	GENEHMIGT VON D. Jeager		
TEIL-NAME Achslagerkonsole		TEIL-CODE 2	DOKUMENTTYP Assambly		WERKSTOFF
UMGESTALTET VON  Open Source Ecology e.V. Knobelsdorffstr. 22 14059 Berlin www.ose-germany.de +49 (0) 30 / 92282426	Originalzeichnung aus Practical ACTION	LIZENZ CERN-OHL	TEIL-NAME oseg_wb_2_Axle-bearing-bracket.iam		VERSION 1.0
			SCALE 1:1	SEITE 12	DATE 11.11.20

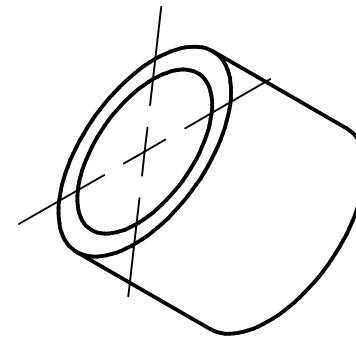
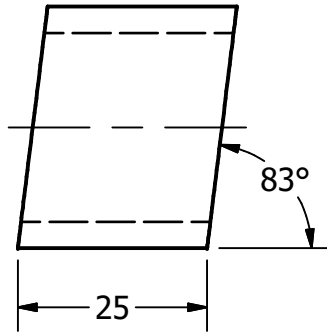
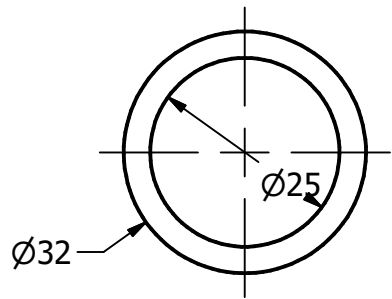

PROJEKT Schubkarre		ERSTELLT VON D. Mosquera	GENEHMIGT VON D. Jeager		
TEIL-NAME Lager		TEIL-CODE 2.1	DOKUMENTTYP part	WERKSTOFF Iron, Gray	
UMGESTALTET VON  Open Source Ecology e.V. Knobelsdorffstr. 22 14059 Berlin www.ose-germany.de +49 (0) 30 / 92282426	Originalzeichnung aus Practical ACTION	LIZENZ CERN-OHL	TEIL-NAME oseg_wb_2.1_bearing.ipt		VERSION 1.0
			SCALE 1:1	SEITE 14	DATE 11.11.20

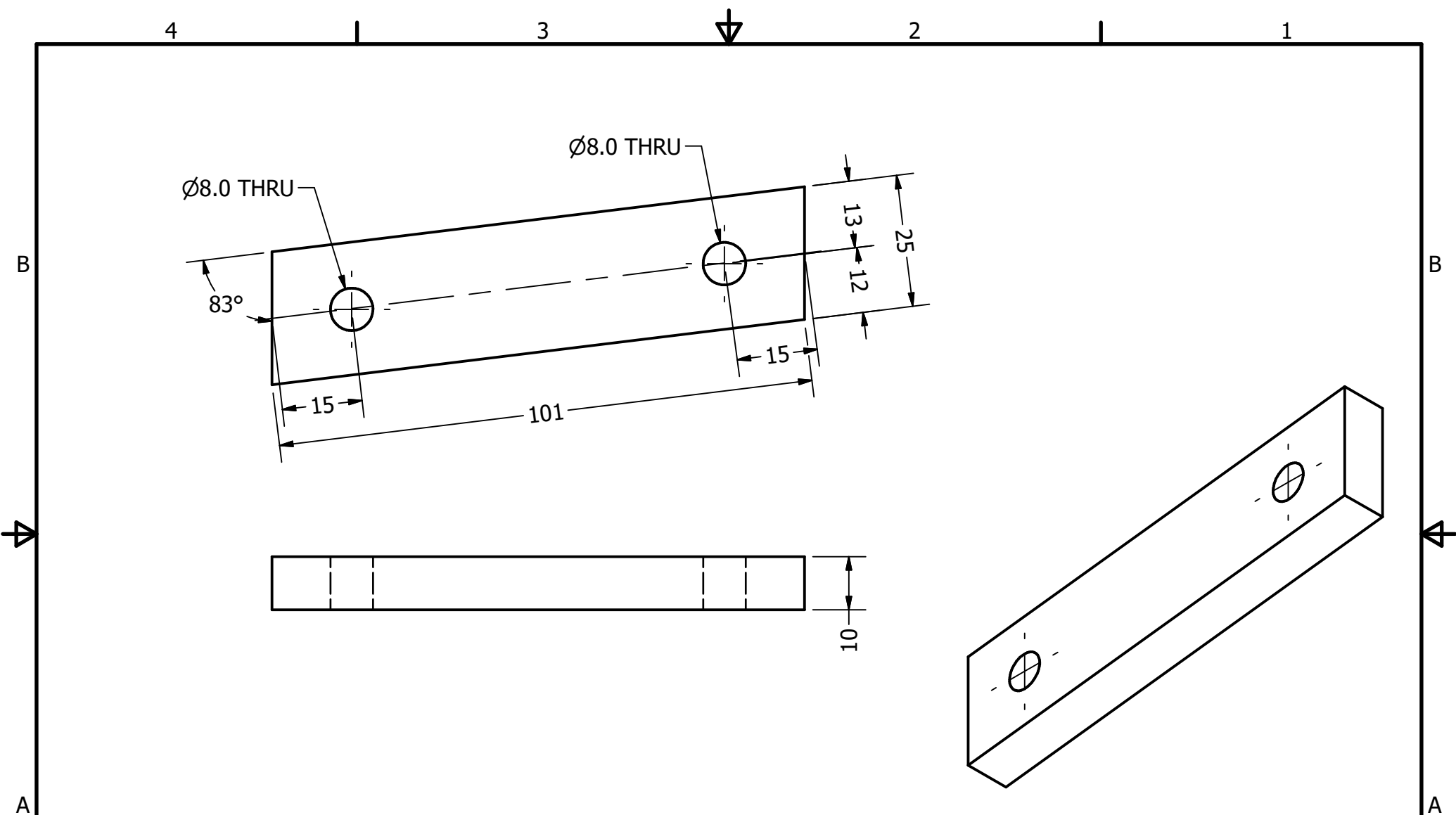

PROJEKT Schubkarre		ERSTELLT VON D. Mosquera	GENEHMIGT VON D. Jeager		
TEIL-NAME Klammern		TEIL-CODE 2.2	DOKUMENTTYP part	WERKSTOFF Iron, Gray	
UMGESTALTET VON	 Open Source Ecology e.V. Knobelsdorffstr. 22 14059 Berlin www.ose-germany.de +49 (0) 30 / 92282426	Originalzeichnung aus	LIZENZ CERN-OHL	TEIL-NAME oseg_wb_2.2_brackets.ipt	VERSION 1.0
		Practical ACTION		SCALE 1:1	SEITE 15

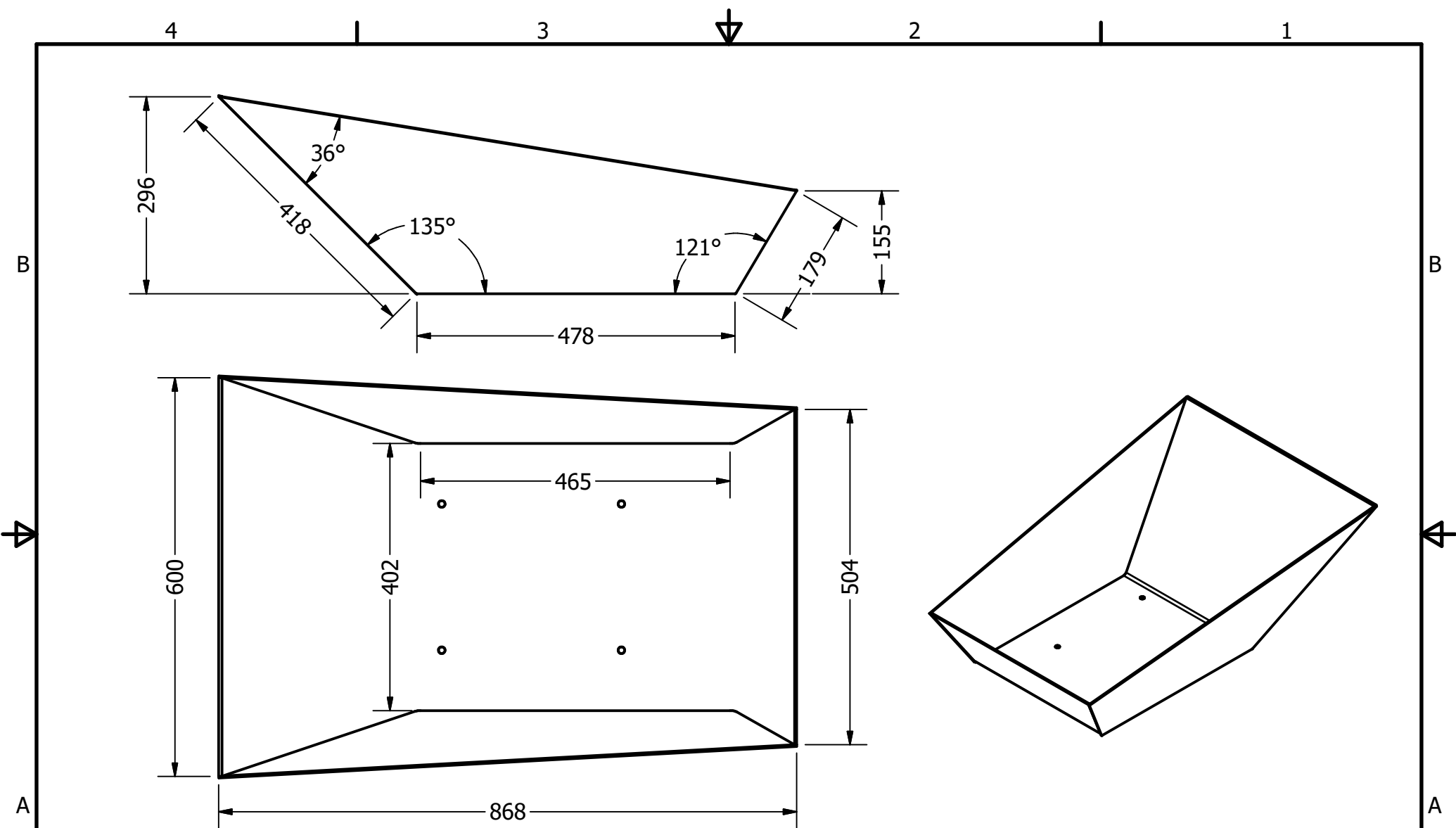

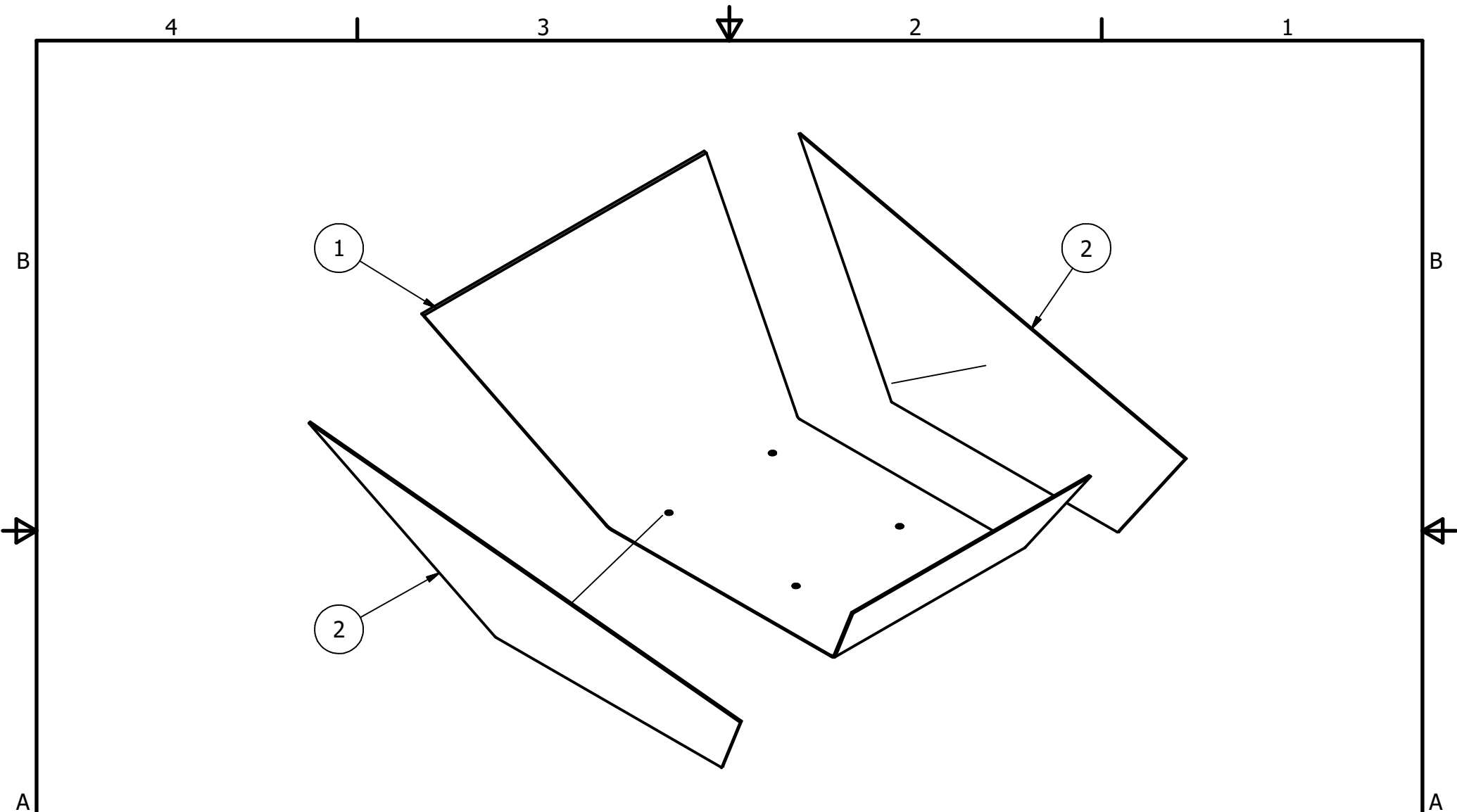

PROJEKT Schubkarre		ERSTELLT VON D. Mosquera		GENEHMIGT VON D. Jeager		
TEIL-NAME Trichter		TEIL-CODE 3		DOKUMENTTYP Assamby		WERKSTOFF
UMGESTALTET VON  Open Source Ecology e.V. Knobelsdorffstr. 22 14059 Berlin www.ose-germany.de +49 (0) 30 / 92282426		Originalzeichnung aus Practical ACTION		LIZENZ CERN-OHL		TEIL-NAME oseg_wb_3_hopper.iam
				SCALE 1:8		VERSION 1.0
						MENGE 16
						DATE 11.11.20

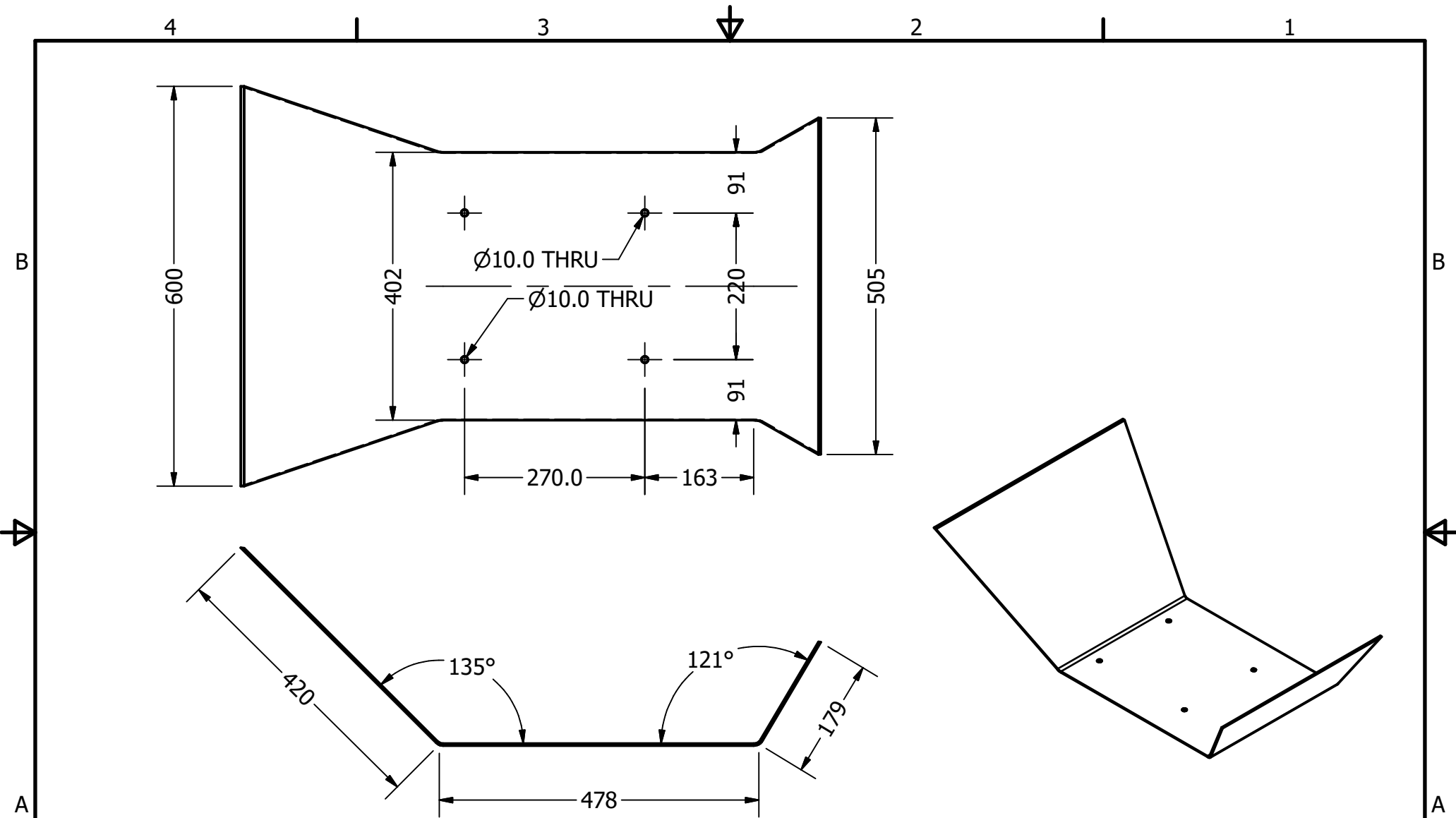

PROJEKT Schubkarre		ERSTELLT VON D. Mosquera	GENEHMIGT VON D. Jeager			
TEIL-NAME Trichter		TEIL-CODE 3	DOKUMENTTYP Assambly		WERKSTOFF	
UMGESTALTET VON  Open Source Ecology e.V. Knobelsdorffstr. 22 14059 Berlin www.ose-germany.de +49 (0) 30 / 92282426	Originalzeichnung aus Practical ACTION	LIZENZ CERN-OHL	TEIL-NAME oseg_wb_3_hopper.ipn		VERSION 1.0	MENGE
			SCALE 1:8	SEITE 17	DATE 11.11.20	



PROJEKT Schubkarre		ERSTELLT VON D. Mosquera		GENEHMIGT VON D. Jeager			
TEIL-NAME Trichterblech		TEIL-CODE 3.1		DOKUMENTTYP part		WERKSTOFF Steel, Mild	
UMGESTALTET VON		Originalzeichnung aus		TEIL-NAME		VERSION	MENGE
 Open Source Ecology e.V. Knobelsdorffstr. 22 14059 Berlin www.ose-germany.de +49 (0) 30 / 92282426				CERN-OHL oseg_wb_3.1_hopper-sheet.ip		1.0	
				SCALE 1:8		SEITE 18	DATE 11.11.20

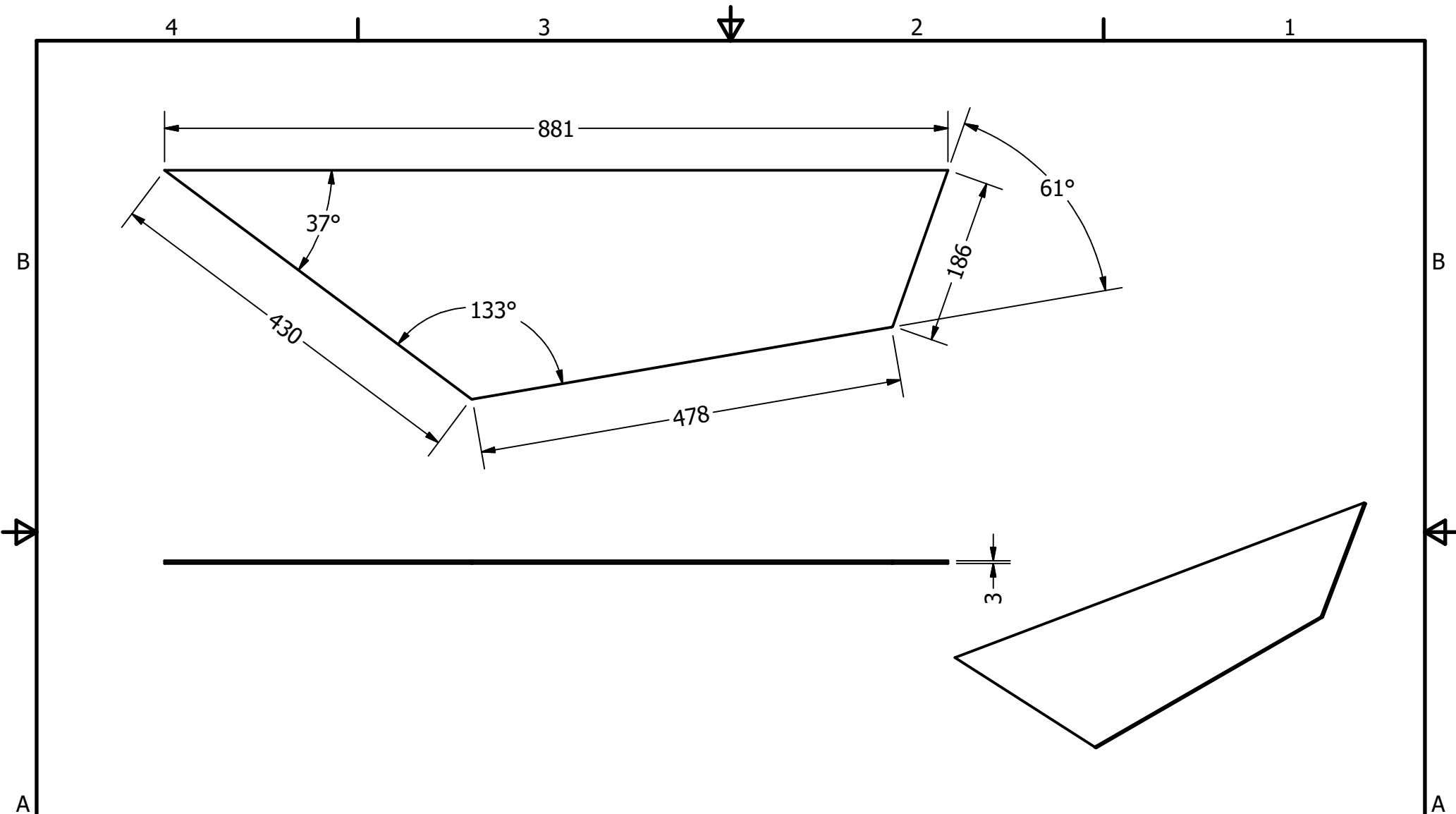

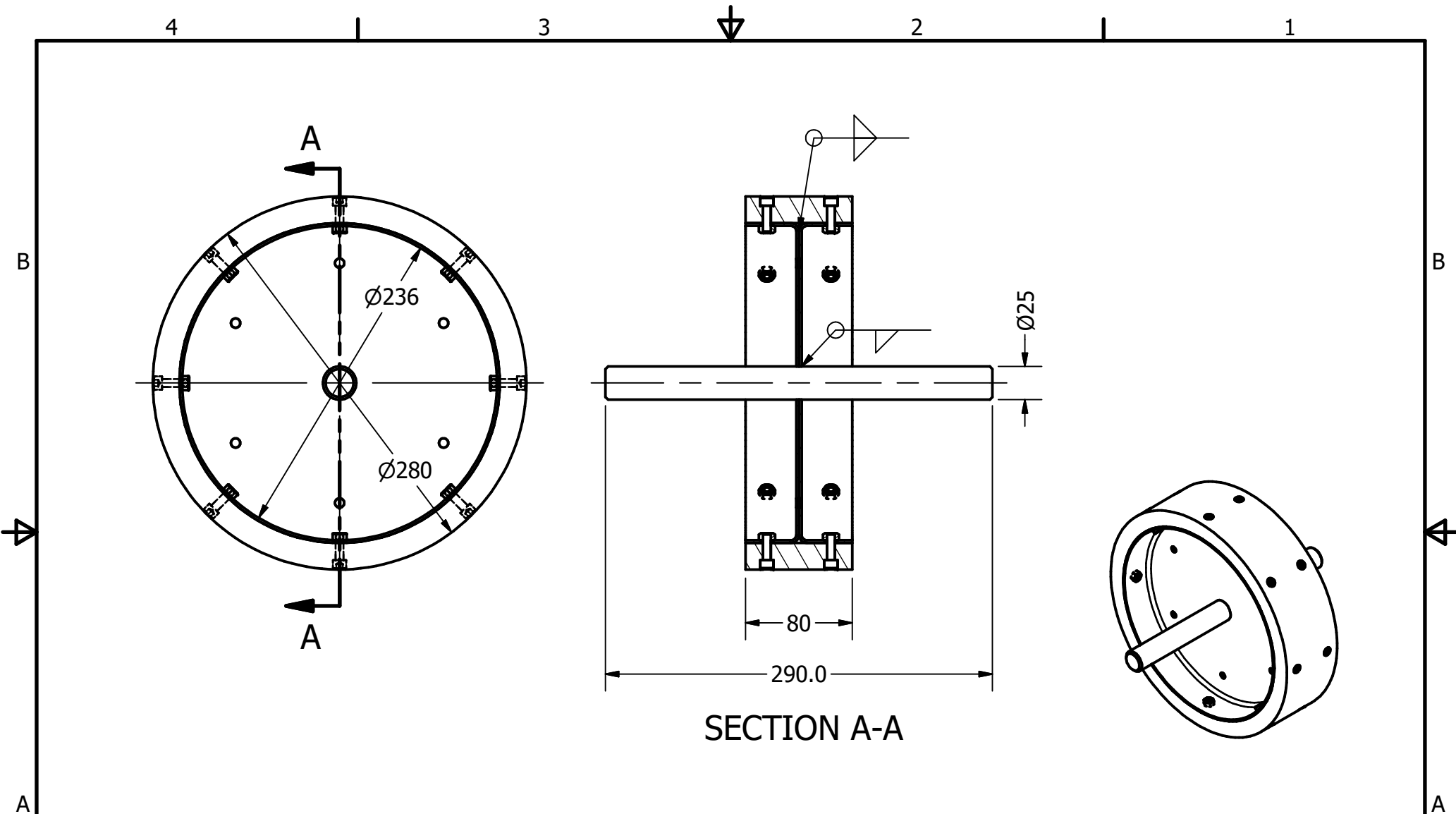

PROJEKT Schubkarre		ERSTELLT VON D. Mosquera	GENEHMIGT VON D. Jeager		
TEIL-NAME Trichterseite		TEIL-CODE 3.2	DOKUMENTTYP part	WERKSTOFF Iron, Gray	
UMGESTALTET VON  Open Source Ecology e.V. Knobelsdorffstr. 22 14059 Berlin www.ose-germany.de +49 (0) 30 / 92282426	Originalzeichnung aus Practical ACTION	LIZENZ CERN-OHL	TEIL-NAME oseg_wb_3.2_hopper-side.ipt	VERSION 1.0	MENGE
			SCALE 1:6	SEITE 19	DATE 11.11.20



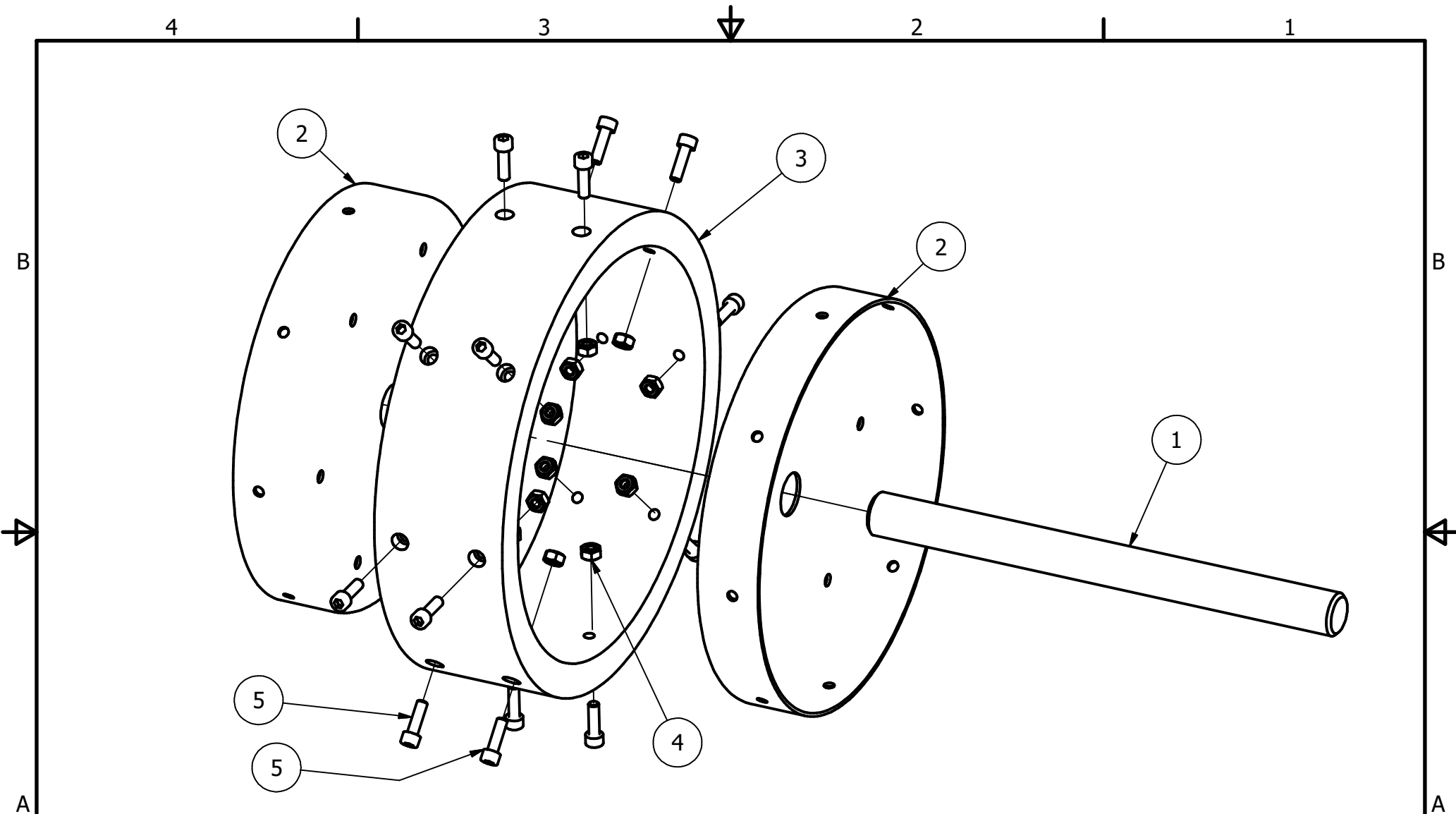

SECTION A-A

PROJEKT Schubkarre		ERSTELLT VON D. Mosquera		GENEHMIGT VON D. Jeager		
TEIL-NAME Rad		TEIL-CODE 4		DOKUMENTTYP Assembly		WERKSTOFF
UMGESTALTET VON  Open Source Ecology e.V. Knobelsdorffstr. 22 14059 Berlin www.ose-germany.de +49 (0) 30 / 92282426		Originalzeichnung aus Practical ACTION		LIZENZ CERN-OHL		TEIL-NAME oseg_wb_4_Wheel.iam
				SCALE 1:4		VERSION 1.0
						MENGE
						DATE 11.11.20
						SEITE 20

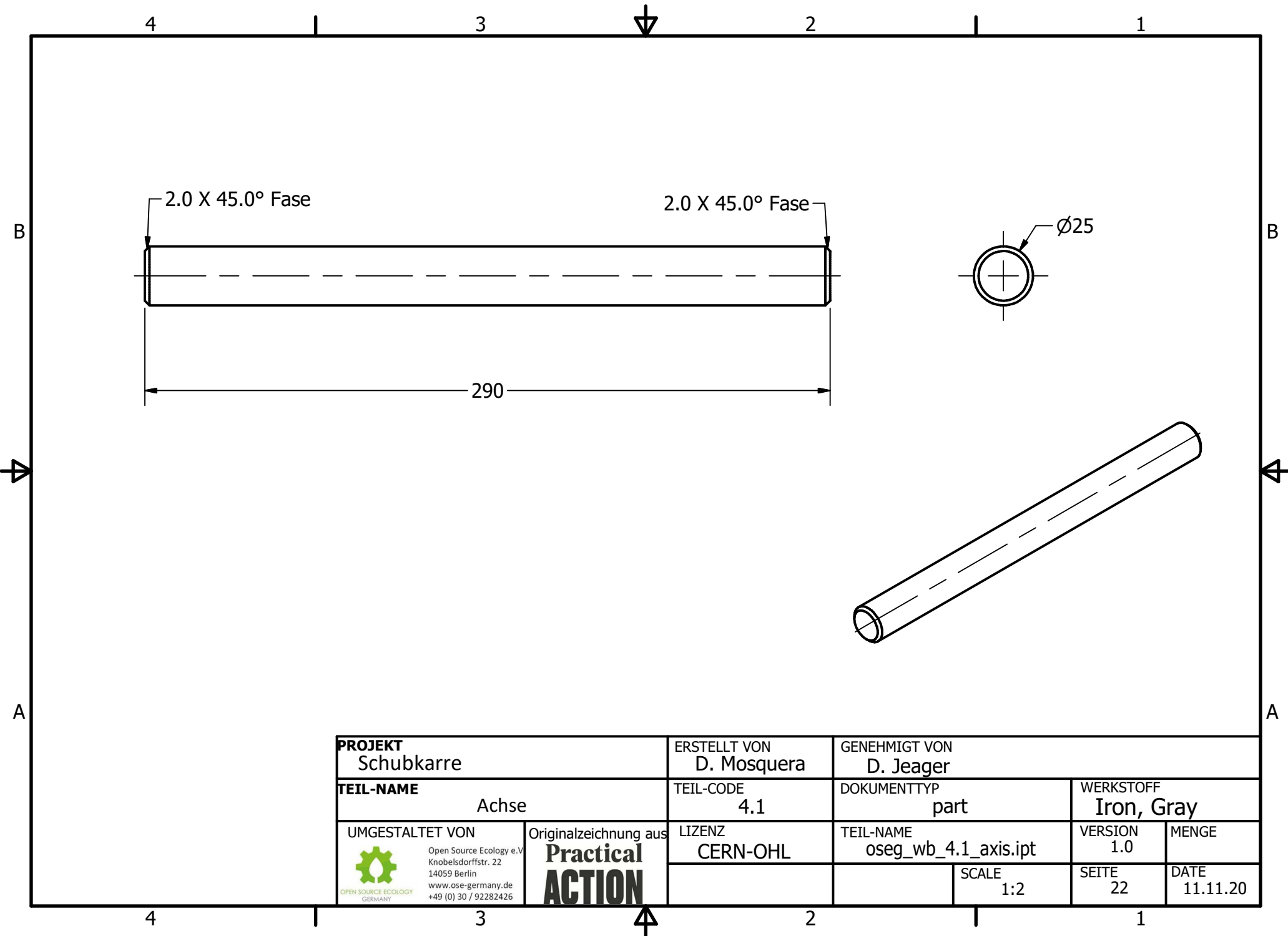

PROJEKT Schubkarre		ERSTELLT VON D. Mosquera	GENEHMIGT VON D. Jeager		
TEIL-NAME Rad		TEIL-CODE 4	DOKUMENTTYP Assembly	WERKSTOFF	
UMGESTALTET VON	 Open Source Ecology e.V. Knobelsdorffstr. 22 14059 Berlin www.ose-germany.de +49 (0) 30 / 92282426	Originalzeichnung aus	LIZENZ CERN-OHL	TEIL-NAME oseg_wb_4_Wheel.iam	VERSION 1.0
		Practical ACTION		SCALE 1:4	SEITE 21



PROJEKT Schubkarre		ERSTELLT VON D. Mosquera	GENEHMIGT VON D. Jeager		
TEIL-NAME Achse		TEIL-CODE 4.1	DOKUMENTTYP part	WERKSTOFF Iron, Gray	
UMGESTALTET VON  Open Source Ecology e.V. Knobelsdorffstr. 22 14059 Berlin www.ose-germany.de +49 (0) 30 / 92282426	Originalzeichnung aus Practical ACTION	LIZENZ CERN-OHL	TEIL-NAME oseg_wb_4.1_axis.ipt	VERSION 1.0	MENGE
			SCALE 1:2	SEITE 22	DATE 11.11.20

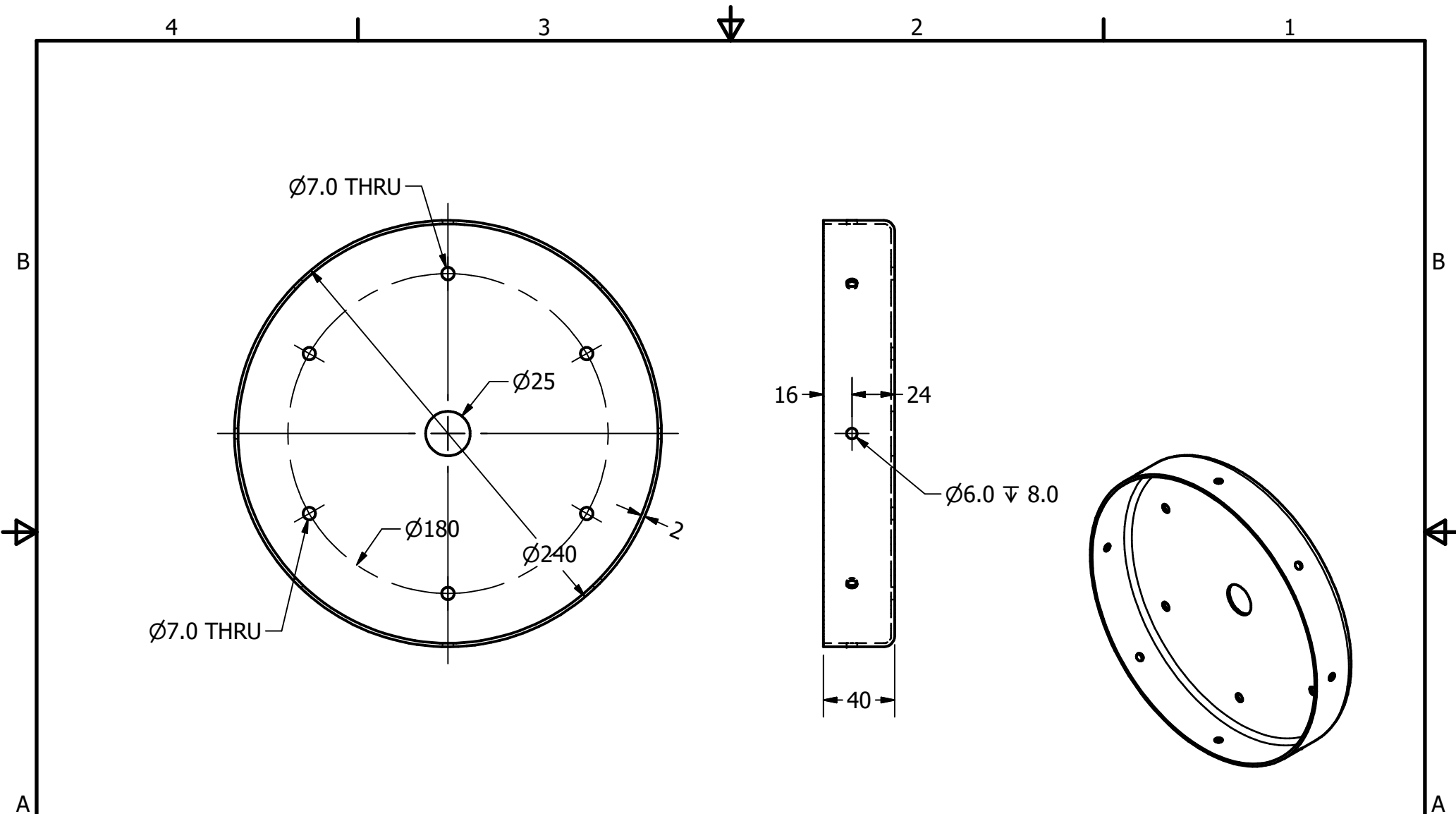

PROJEKT Schubkarre		ERSTELLT VON D. Mosquera		GENEHMIGT VON D. Jeager		
TEIL-NAME Radarmatur		TEIL-CODE 4.2		DOKUMENTTYP part		WERKSTOFF Iron, Gray
UMGESTALTET VON  Open Source Ecology e.V. Knobelsdorffstr. 22 14059 Berlin www.ose-germany.de +49 (0) 30 / 92282426		Originalzeichnung aus Practical ACTION		LIZENZ CERN-OHL		TEIL-NAME oseg_wb_4.2_wheel-armature.ipt
				SCALE 1:2		VERSION 1.0
						MENGE SEITE DATE 11.11.20

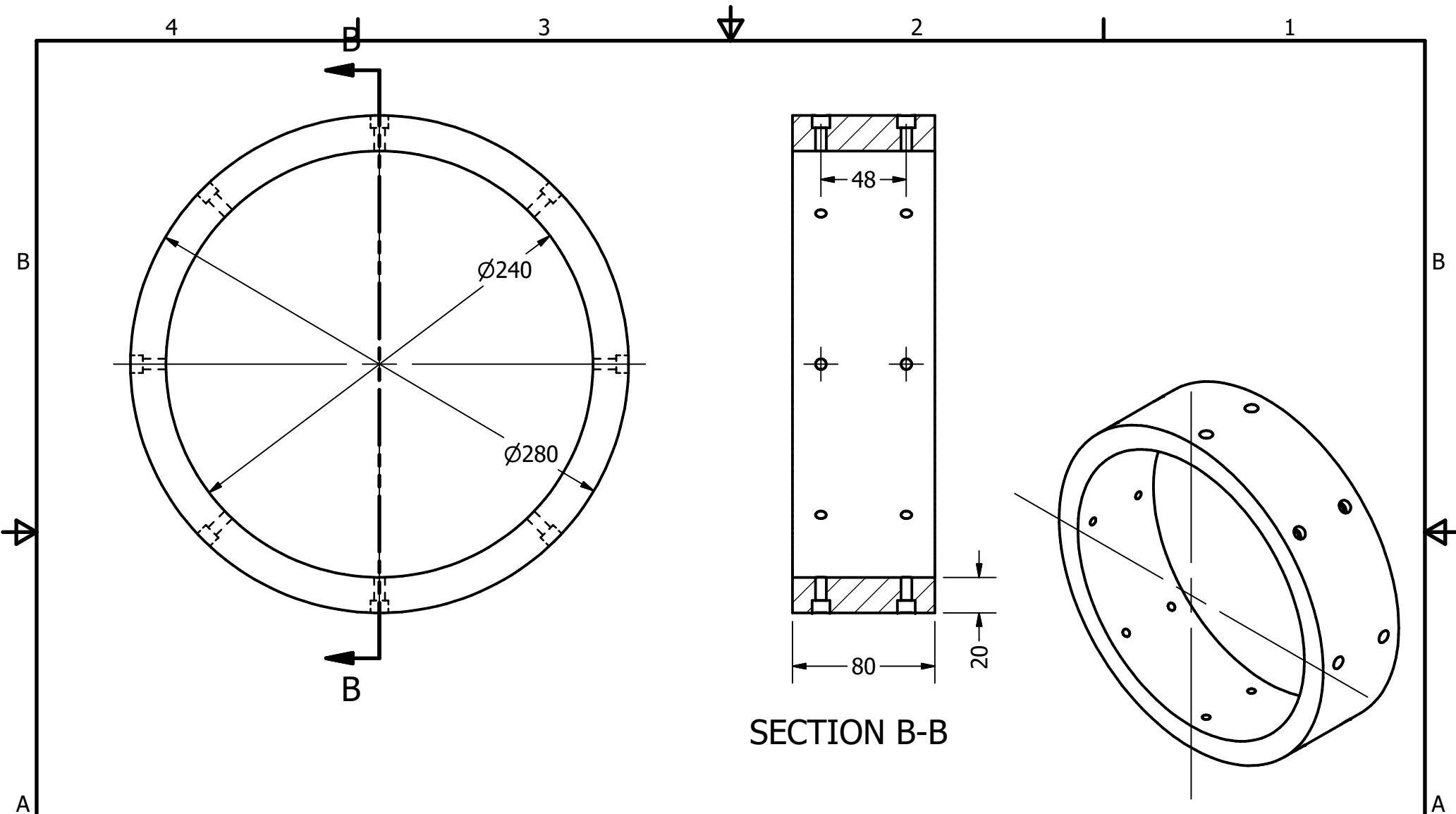

SECTION B-B

PROJEKT Schubkarre		ERSTELLT VON D. Mosquera		GENEHMIGT VON D. Jeager	
TEIL-NAME Streifen eines Reifens		TEIL-CODE 4.3		DOKUMENTTYP part	
UMGESTALTET VON  Open Source Ecology e.V. Knobelsdorffstr. 22 14059 Berlin www.ose-germany.de +49 (0) 30 / 92282426		Originalzeichnung aus Practical ACTION		LIZENZ CERN-OHL	
				TEIL-NAME oseg_wb_4.3_strip-of-tyre.ipt	
				VERSION 1.0	
				MENGE	
				SCALE 1:3	
				SEITE 24	
				DATE 11.11.20	