

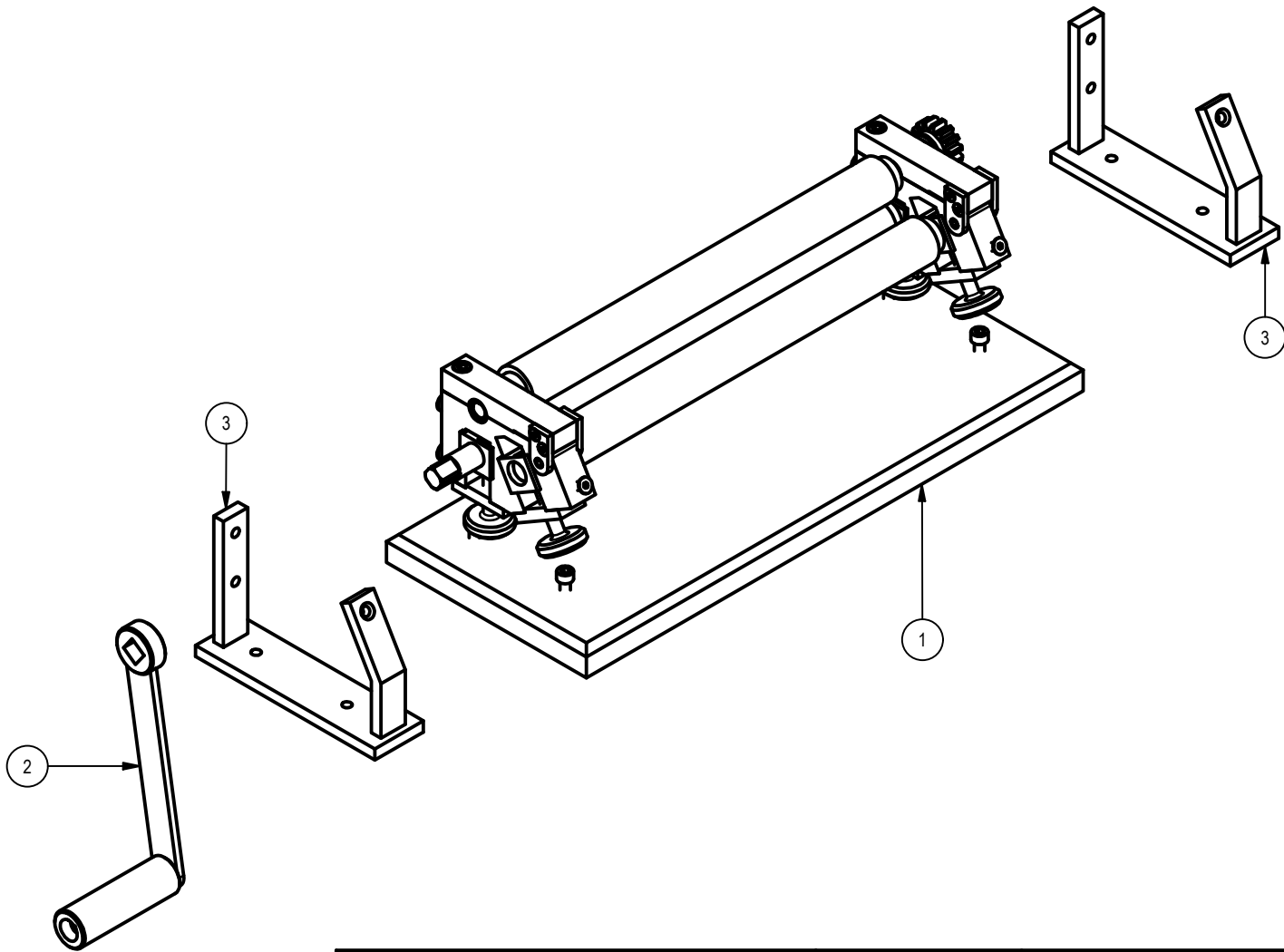

PROJECT PLATE ROLLING MACHINE	CREATED BY A. PARDO	APPROVED BY D. JAEGER		
PART NAME PLATE ROLLING MACHINE	PART CODE A1	DOCUMENT TYPE ASSEMBLY	MATERIAL STEEL METAL	
 Open Source Ecology e.V. Knobelsdorfstr. 22 14059 Berlin <a href="http://www.os-e-germany.de">www.os-e-germany.de</a> +49 (0) 30 / 93282426	LICENSE CERN-OHL	FILE NAME PLATE ROLLING MACHINE.iam	VERSION 1.0	QUANTITY 1
		SCALE 1 / 2.5	SHEET 1	DATE 10/10/2020



PROJECT <b>PLATE ROLLING MACHINE</b>		CREATED BY <b>A. PARDO</b>		APPROVED BY <b>D. JAEGER</b>	
PART NAME <b>PLATE ROLLING MACHINE</b>		PART CODE <b>A2</b>		DOCUMENT TYPE <b>ASSEMBLY</b>	
 Open Source Ecology e.V. Knobelsdorffstr. 22 14059 Berlin <a href="http://www.os-e-germany.de">www.os-e-germany.de</a> +49 (0) 30 / 93282426		LICENSE <b>CERN-OHL</b>		FILE NAME <b>PLATE ROLLING MACHINE.iam</b>	
		SCALE <b>1 / 4</b>		VERSION <b>1.0</b>	
		SHEET <b>2</b>		QUANTITY <b>1</b>	
		DATE <b>10/10/2020</b>			

PARTS LIST								
POS.	POS. OLD	QTY	SHEET	PARTS NAME	FILE NAME	PARTS TYPE	SPECIFICATION	
A1		1	1	PLATE ROLLING MACHINE	base plate.ipt	ASSEMBLY		
A2		1	2	PLATE ROLLING MACHINE		ASSEMBLY		
B1		1	3	PARTS LIST PLATE ROLLING MACHINE		PARTS LIST		
1		1	4	ROLLER		ASSEMBLY		
1.1	15	1	5	BASE PLATE		PARTS		
1.2	3	2	6	HINGE	hinge.ipt	PARTS		
1.3	4A	2	7	HINGE SEAT A	hinge seat A.ipt	PARTS		
1.4	4B	2	8	HINGE SEAT B	hinge seat B.ipt	PARTS		
1.5	5	4	9	PLATE	plate.ipt	PARTS		
1.6	2	2	10	POSITION 2	position 2.ipt	PART		
1.7	8	4	11	POSITION 8	position 8.ipt	PART		
1.8	6	4	12	PRESSURE SCREW	pressure screw.ipt	PARTS		
1.9	14	1	13	ROLLER A	rollerA.ipt	PARTS		
1.10	13	1	14	ROLLER B	rollerB.ipt	PARTS		
1.11	12	1	15	ROLLER C	rollerC.ipt	PARTS		
1.12	9	1	16	BEARING A	bearingA.ipt	PARTS		
1.13	10	1	17	BEARING B	bearingB.ipt	PARTS		
1.14		2	18	CRADLE	CRADLE.ipt	PART		
1.15	7	2	19	GEAR	gear.ipt	PART		
1.16		10		Broached Hexagon Socket Flat Countersunk Head Cap Screws - Metric	ASME_ANSI B18.3.5M - M5x14(2).ipt			
1.17		8		Broached Hexagon Socket Flat Countersunk Head Cap Screws - Metric	ASME_ANSI B18.3.5M - M4x10(2).ipt			
1.18		6		Broached Socket Head Cap Screw - Metric	ANSI B18.3.1M - M6x1 x 20(2).ipt			
1.19		2		Pin - Coiled Spring (Metric)	IFI 512-C - 6 x 28280,5.ipt			
1.20		4		Broached Hexagon Socket Flat Countersunk Head Cap Screws - Metric	ASME_ANSI B18.3.5M - M6x20(2).ipt			
2		1	20	CRANK HANDLE		ASSEMBLY		
2.1	11	1	21	CRANK HANDLE 1	crank handle1.ipt	PARTS		
2.2	11	1	22	CRANK HANDLE 2	crank handle2.ipt	PARTS		
2.3	11	1	23	CRANK HANDLE 3	crank handle3.ipt	PARTS		
2.4		1		Drilled Forged Hexagon Socket Head Cap Screw - Metric	ANSI B18.3.1M - M8x1,25 x 70(4).ipt			
3		1	24	POSITION		ASSEMBLY		
3.1	1A	2	25	POSITION 1A	position 1A.ipt	PARTS		
3.2	1B	2	26	POSITION 1B	position 1B.ipt	PARTS		
3.3	1C	2	27	POSITION 1C	position 1C.ipt	PARTS		

PROJECT <b>PLATE ROLLING MACHINE</b>		CREATED BY <b>A. PARDO</b>		APPROVED BY <b>D. JAEGER</b>	
PART NAME <b>PLATE ROLLING MACHINE</b>		PART CODE <b>B1</b>		DOCUMENT TYPE <b>ASSEMBLY</b>	
 Open Source Ecology e.V. Knobelsdorffstr. 22 14059 Berlin www.ose-germany.de +49 (0) 30 / 92282426		LICENSE <b>CERN-OHL</b>		FILE NAME PARTS LIST PLATE ROLLING MACHINE.iam	
		SCALE		VERSION 1.0	
		SHEET 4		QUANTITY 1	
		DATE 10/10/2020			

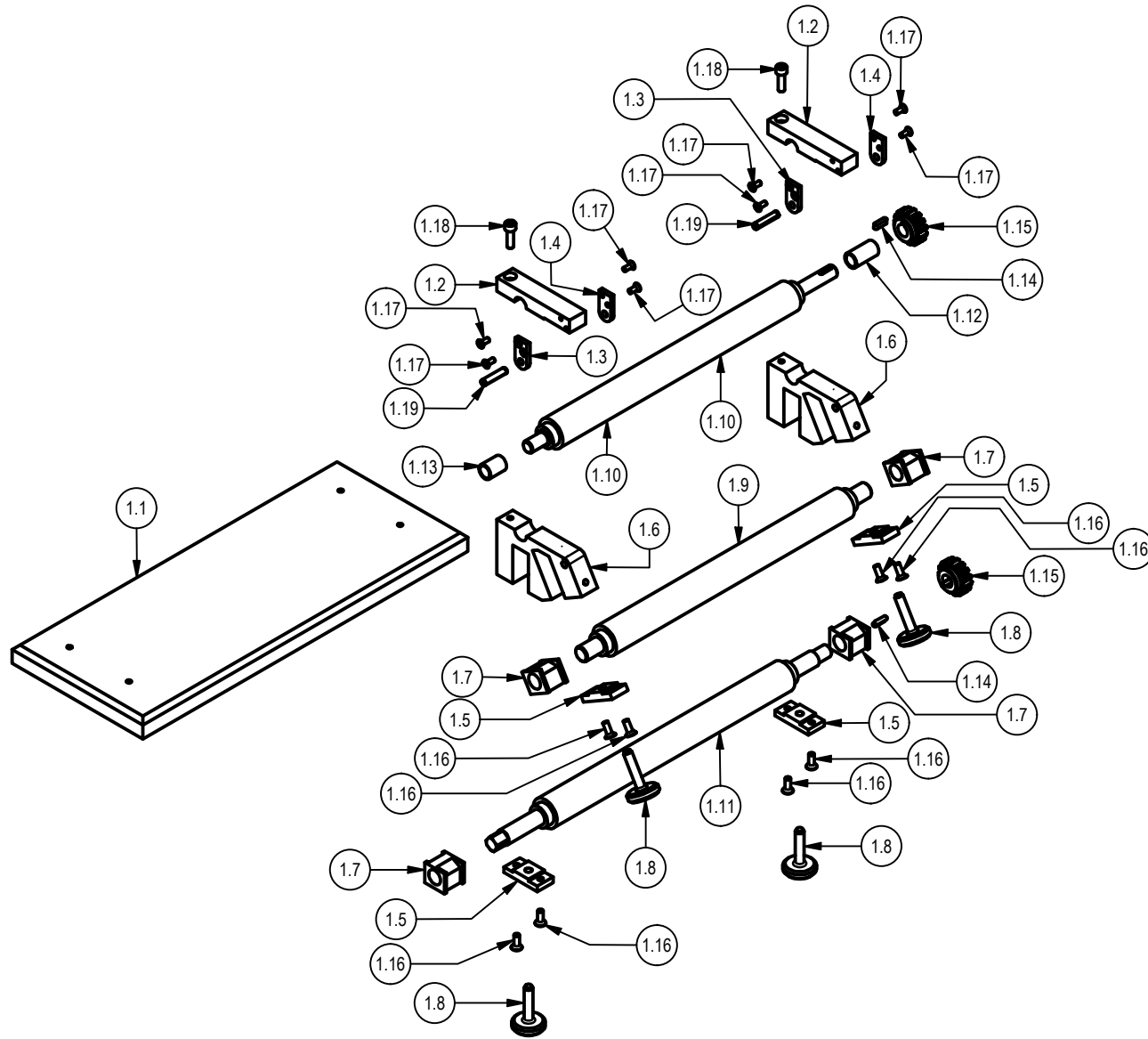

PROJECT PLATE ROLLING MACHINE	CREATED BY A. PARDO	APPROVED BY D. JAEGER		
PART NAME ROLLER	PART CODE 1	DOCUMENT TYPE ASSEMBLY	MATERIAL STEEL MEATL	
 <p>Open Source Ecology e.V. Knobelsdorffstr. 22 14059 Berlin www.ose-germany.de +49 (0) 30 / 92282425</p>	LICENSE CERN-OHL	FILE NAME ROLLER.iam	VERSION 1.0	QUANTITY 1
		SCALE 1 : 6	SHEET 4	DATE 10/10/2020

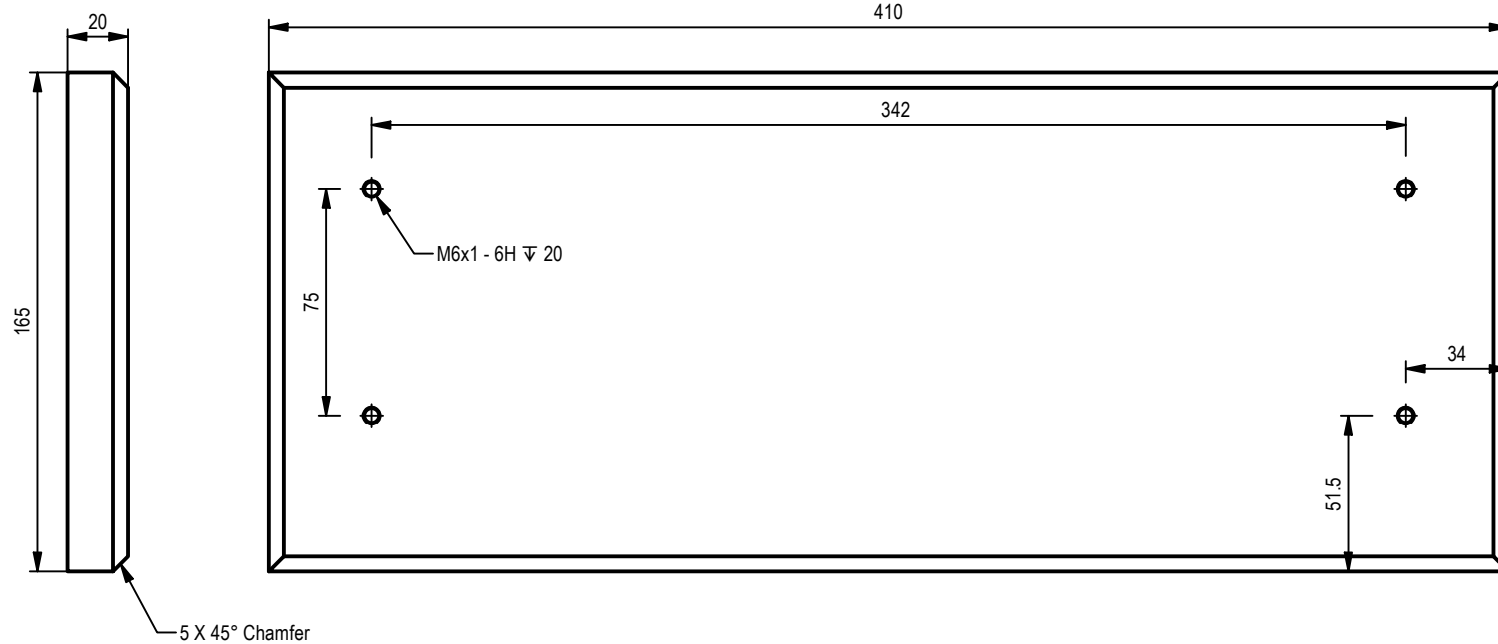
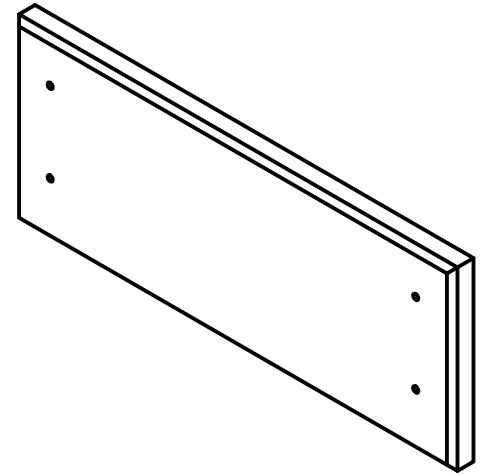

PROJECT PLATE ROLLING MACHINE		CREATED BY A. PARDO		APPROVED BY D. JAEGER	
PART NAME BASE PLATE		PART CODE 1.1		DOCUMENT TYPE PART	
 Open Source Ecology e.V. Knobelsdorffstr. 22 14059 Berlin <a href="http://www.ose-germany.de">www.ose-germany.de</a> +49 (0) 30 / 92282426		LICENSE CERN-OHL		FILE NAME base plate.ipt	
		SCALE 1 / 2.5		MATERIAL STEEL C45	
		VERSION 1.0		QUANTITY 1	
		SHEET 5		DATE 9/10/2020	

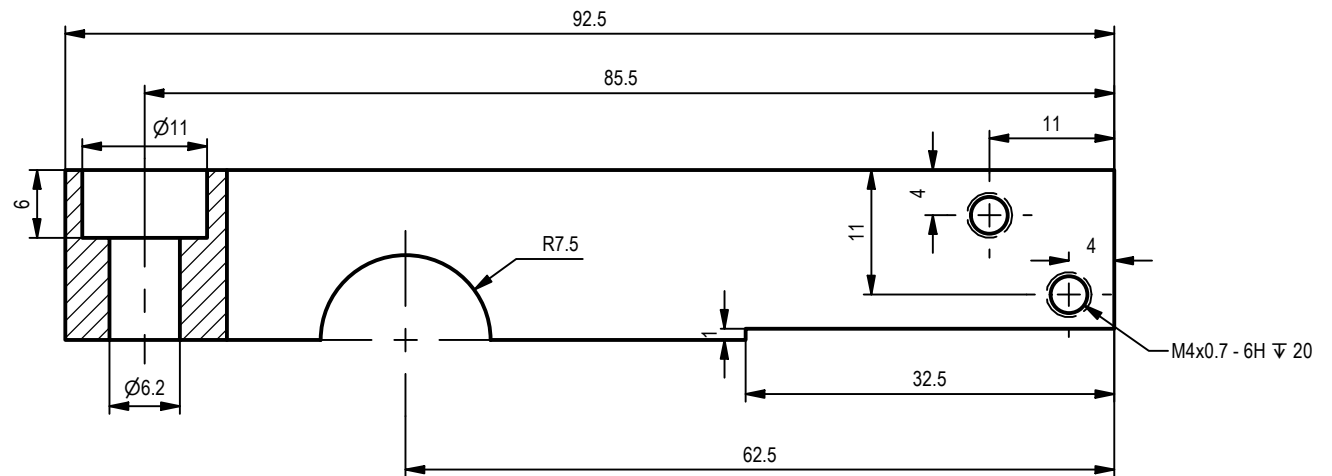
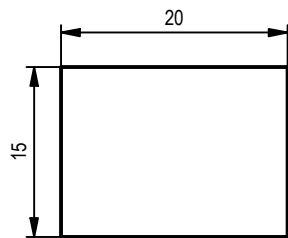
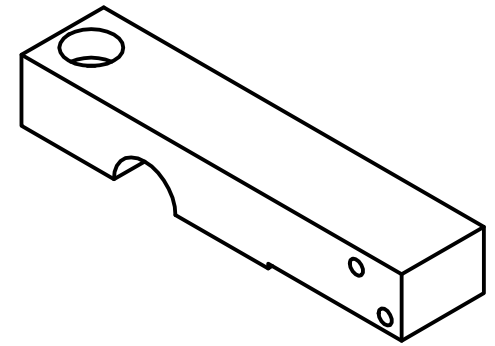

PROJECT PLATE ROLLING MACHINE	CREATED BY A. PARDO	APPROVED BY D. JAEGER		
PART NAME HINGE	PART CODE 1.2	DOCUMENT TYPE PART	MATERIAL STEEL C45	
 Open Source Ecology e.V. Knobelndorfstr. 22 14059 Berlin www.os-e-germany.de +49 (0) 30 / 93282426	LICENSE CERN-OHL	FILE NAME hinge.ipt	VERSION 1.0	QUANTITY 1
		SCALE 1.5 : 1	SHEET 6	DATE 9/10/2020

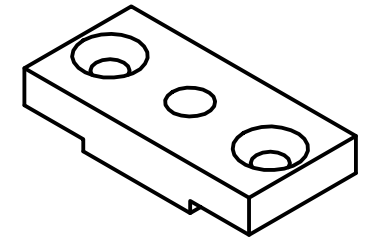

SECTION MH-MH  
SCALE 1.5 : 1

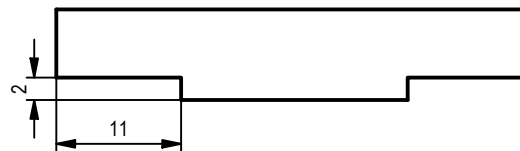
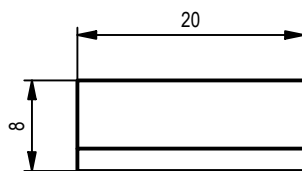
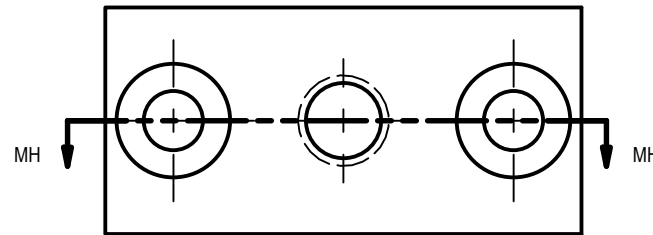
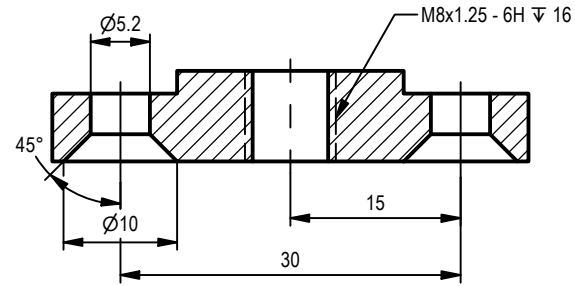

PROJECT PLATE ROLLING MACHINE		CREATED BY A. PARDO		APPROVED BY D. JAEGER	
PART NAME PLATE		PART CODE 1.5		DOCUMENT TYPE PART	
 Open Source Ecology e.V. Knobelsdorffstr. 22 14059 Berlin www.os-e-germany.de +49 (0) 30 / 92282426		LICENSE CERN-OHL		MATERIAL STEEL C45	
		FILE NAME plate.ipt		VERSION 1.0	
		SCALE 1.5 : 1		SHEET 9	
				DATE 9/10/2020	

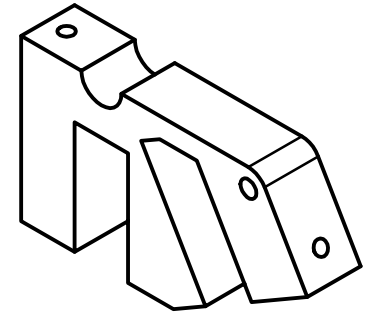

SECTION MG-MG  
SCALE 1 : 1.3

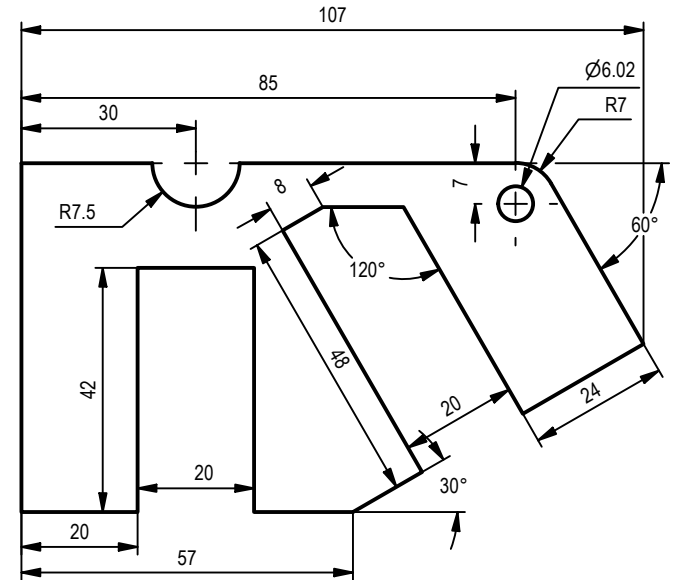
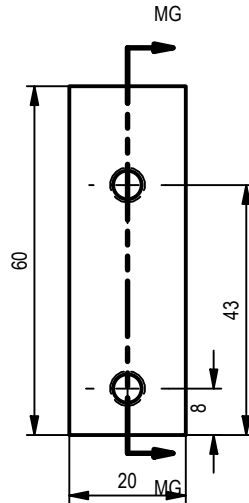
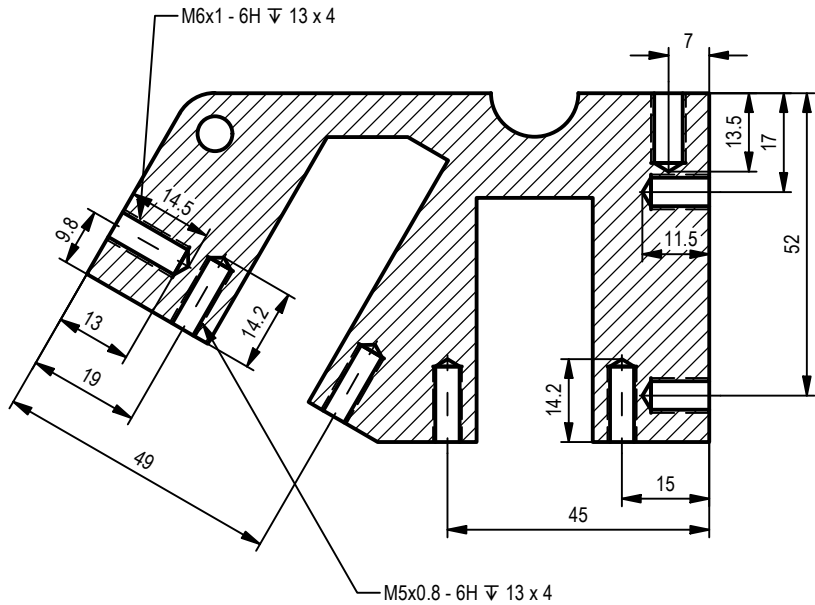

PROJECT PLATE ROLLING MACHINE		CREATED BY A. PARDO		APPROVED BY D. JAEGER	
PART NAME POSITION 2		PART CODE 1.6		DOCUMENT TYPE PART	
 Open Source Ecology e.V. Knobelsdorffstr. 22 14059 Berlin www.os-e-germany.de +49 (0) 30 / 93283426		LICENSE CERN-OHL		FILE NAME position 2.ipt	
		SCALE 1 : 1.3		VERSION 10	
		MATERIAL STEEL C45		QUANTITY 1	
		SHEET 10		DATE 10/10/2020	



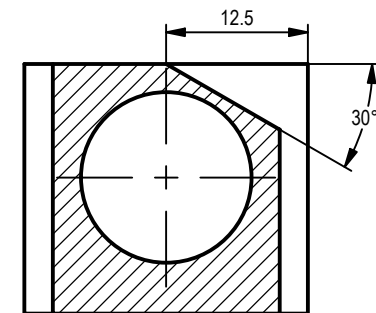
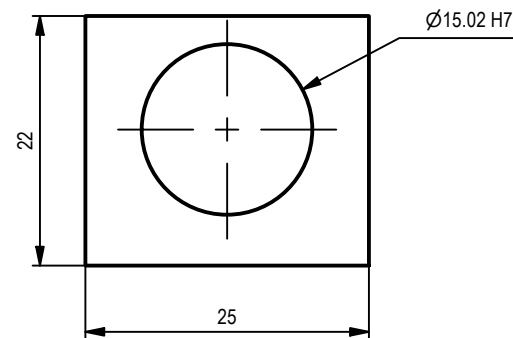
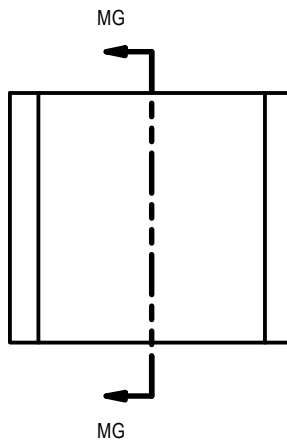
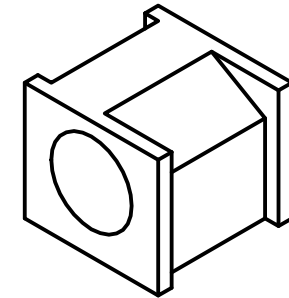
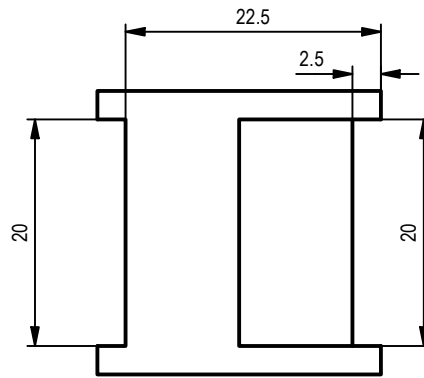

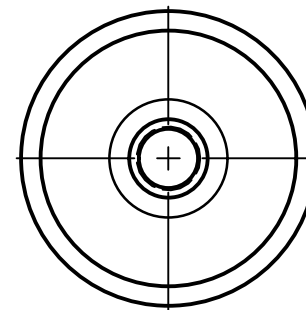
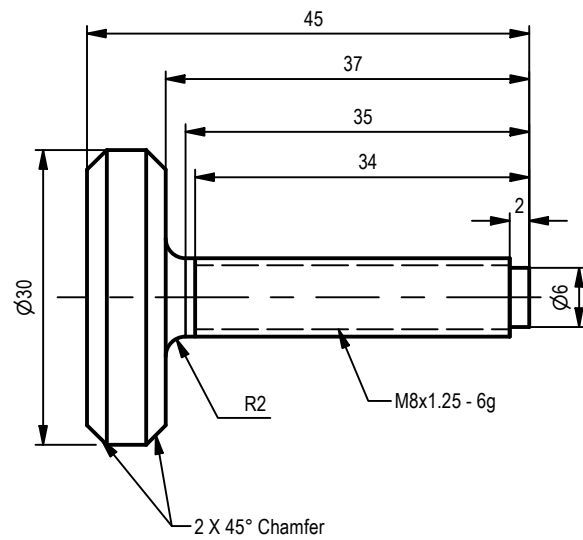
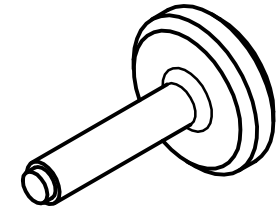

SECTION MG-MG  
SCALE 1.5 : 1

PROJECT PLATE ROLLING MACHINE		CREATED BY A. PARDO		APPROVED BY D. JAEGER	
PART NAME POSITION 8		PART CODE 1.7		DOCUMENT TYPE PART	
 <p>Open Source Ecology e.V. Knobelsdorffstr. 22 14059 Berlin www.ose-germany.de +49 (0) 30 / 92282426</p>		LICENSE CERN-OHL		FILE NAME position 8.ipt	
		SCALE 1.5 : 1		MATERIAL STEEL C45	
		VERSION 1.0		QUANTITY 1	
		SHEET 11		DATE 10/10/2020	

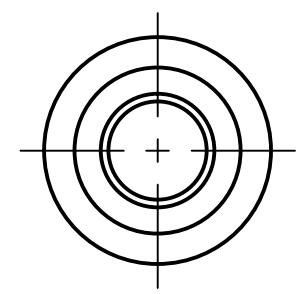
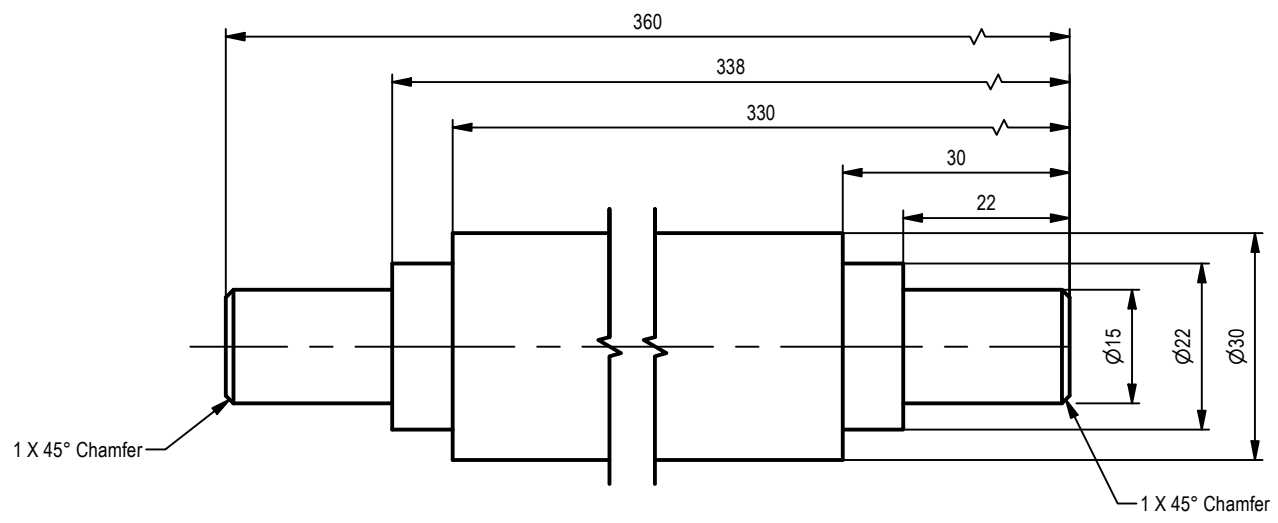
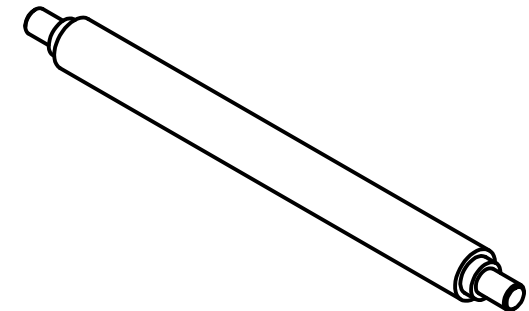

PROJECT PLATE ROLLING MACHINE	CREATED BY A. PARDO	APPROVED BY D. JAEGER		
PART NAME PRESSURE SCREW	PART CODE 1.8	DOCUMENT TYPE PART	MATERIAL STEEL C45	
 Open Source Ecology e.V. Knobelsdorffstr. 22 14059 Berlin www.osc-germany.de +49 (0) 30 / 92282426	LICENSE CERN-OHL	FILE NAME pressure_screw.ipt	VERSION 1.0	QUANTITY 1
		SCALE 1.3: 1	SHEET 12	DATE 9/10/2020



PROJECT PLATE ROLLING MACHINE		CREATED BY A. PARDO		APPROVED BY D. JAEGER	
PART NAME ROLLER A		PART CODE 1.9		DOCUMENT TYPE PART	
 Open Source Ecology e.V. Knobelsdorffstr. 22 14059 Berlin <a href="http://www.osc-germany.de">www.osc-germany.de</a> +49 (0) 30 / 92282426		LICENSE CERN-OHL		FILE NAME rollerA.ipt	
		SCALE 1 / 4		MATERIAL STEEL C45	
		VERSION 1.0		QUANTITY 1	
		SHEET 13		DATE 9/10/2020	

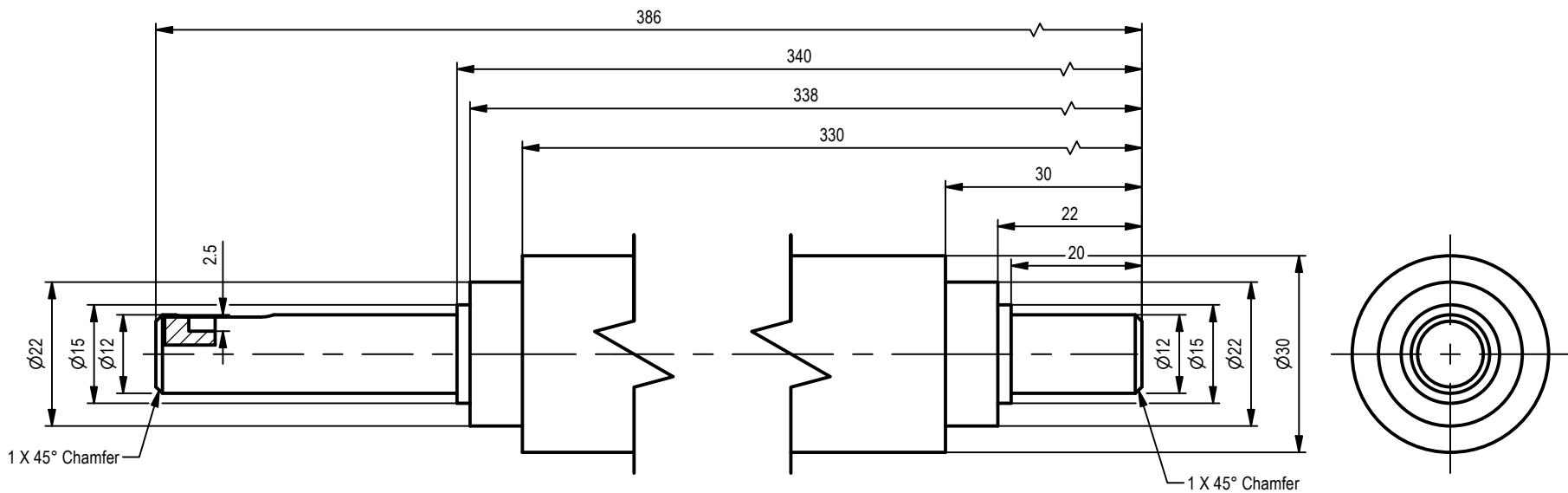
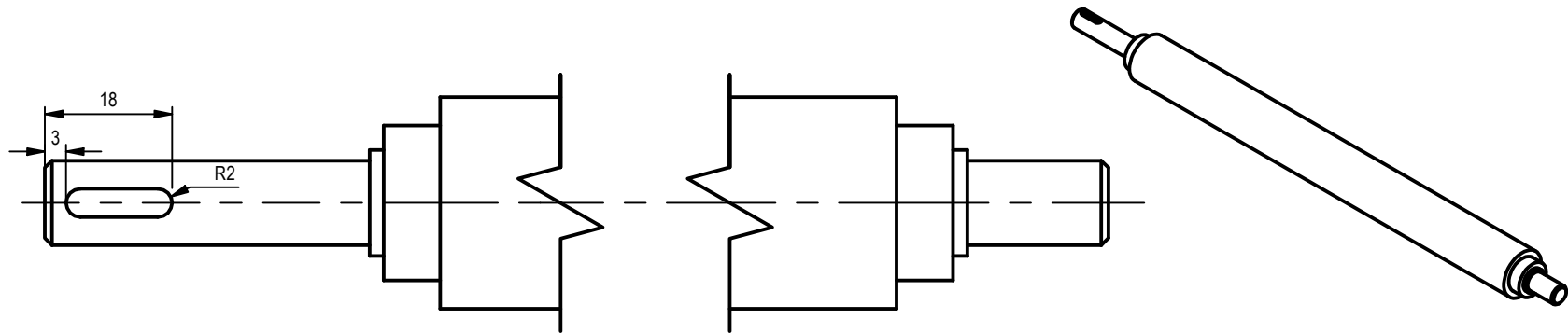

PROJECT PLATE ROLLING MACHINE		CREATED BY A. PARDO		APPROVED BY D. JAEGER	
PART NAME ROLLER B		PART CODE 1.10		DOCUMENT TYPE PART	
 Open Source Ecology e.V. Knobelsdorffstr. 22 14059 Berlin www.ose-germany.de +49 (0) 30 / 92282426		LICENSE CERN-OHL		FILE NAME rollerB.ipt	
		SCALE 1:1		MATERIAL STEEL C45	
		VERSION 1.0		QUANTITY 1	
		SHEET 14		DATE 9/10/2020	

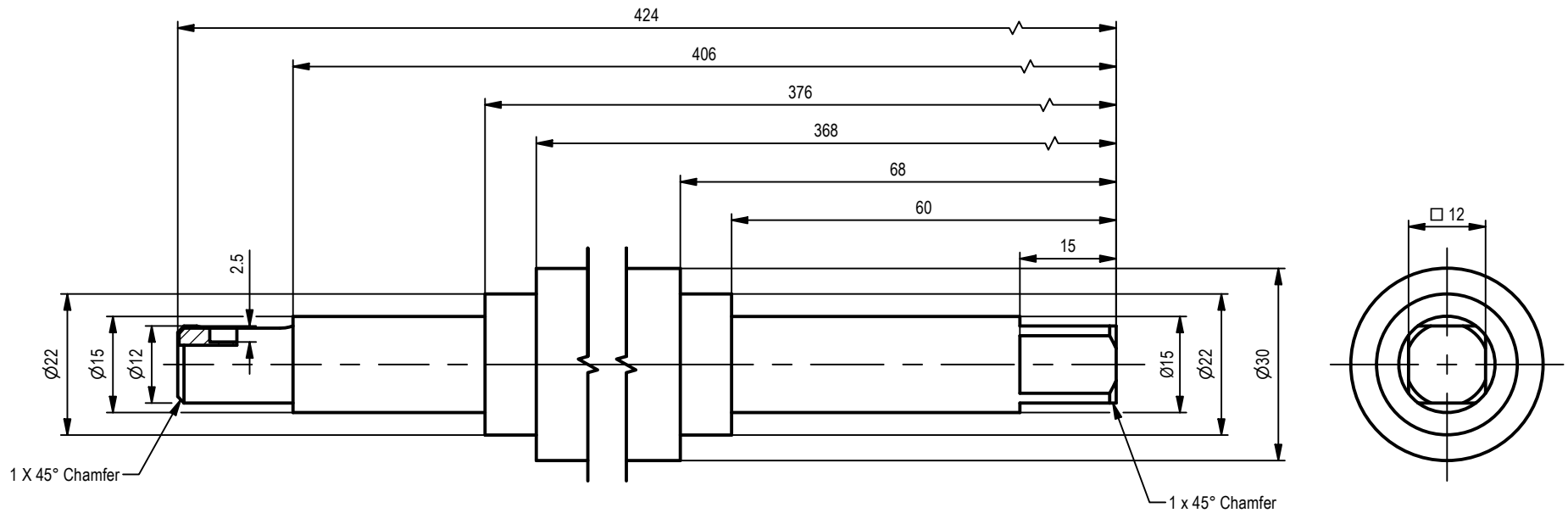
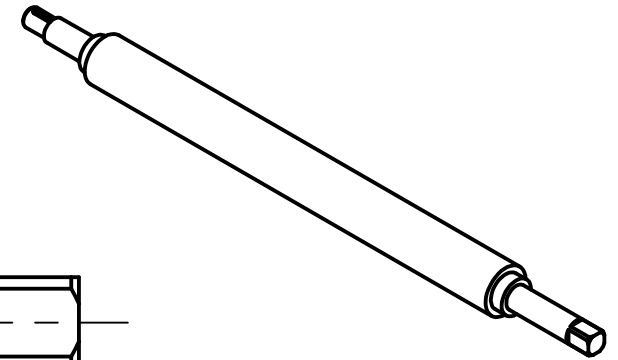
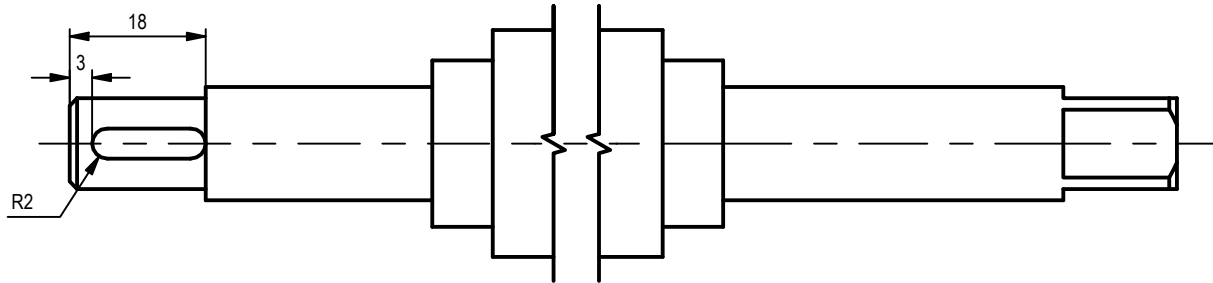

PROJECT PLATE ROLLING MACHINE		CREATED BY A. PARDO		APPROVED BY D. JAEGER	
PART NAME ROLLER C		PART CODE 1.11		DOCUMENT TYPE PART	
 Open Source Ecology e.V. Knobelsdorfstr. 22 14059 Berlin www.osc-germany.de +49 (0) 30 / 92282426		LICENSE CERN-OHL		FILE NAME rollerC.ipt	
		SCALE 1 : 1		MATERIAL STEEL C45	
		VERSION 1.0		QUANTITY 1	
		SHEET 15		DATE 9/10/2020	

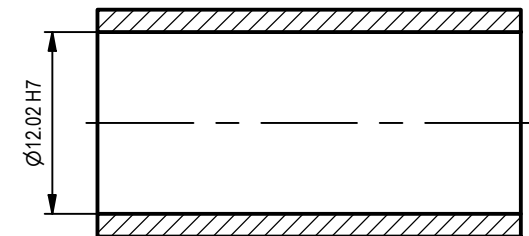
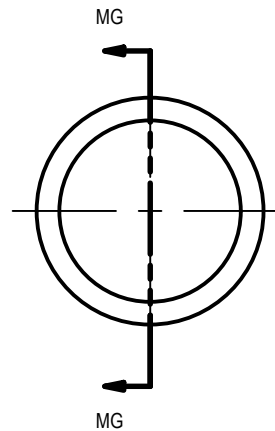
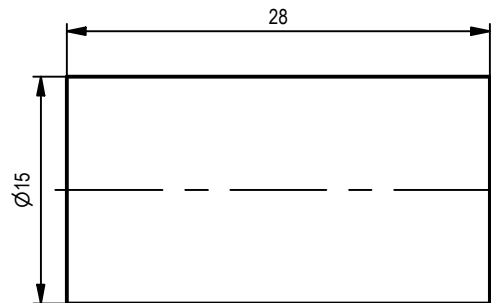
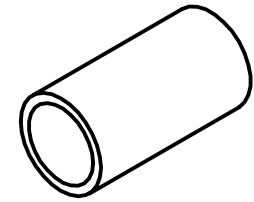

SECTION MG-MG  
SCALE 2 : 1

PROJECT <b>PLATE ROLLING MACHINE</b>		CREATED BY <b>A. PARDO</b>		APPROVED BY <b>D. JAEGER</b>	
PART NAME <b>BEARING A</b>		PART CODE <b>1.12</b>		DOCUMENT TYPE <b>PART</b>	
 <p>Open Source Ecology e.V. Knobelsdorffstr. 22 14059 Berlin www.os-e-germany.de +49 (0) 30 / 92282426</p>		LICENSE <b>CERN-OHL</b>		MATERIAL <b>STEEL C45</b>	
		FILE NAME bearingA.ipt		VERSION 1.0	
		SCALE 2 : 1		SHEET 16	
				DATE 9/10/2020	

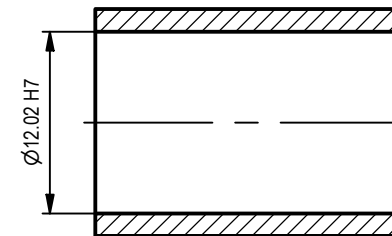
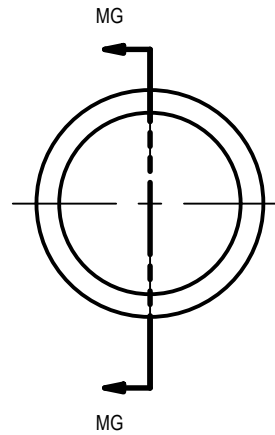
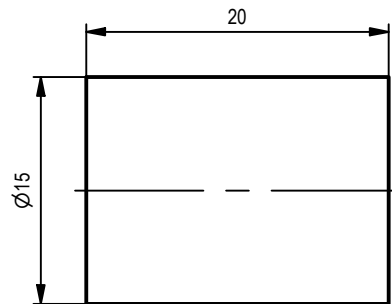
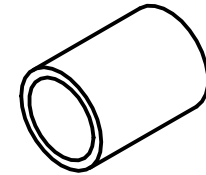

SECTION MG-MG  
SCALE 2 : 1

PROJECT PLATE ROLLING MACHINE		CREATED BY A. PARDO		APPROVED BY D. JAEGER	
PART NAME BEARING B		PART CODE 1.13		DOCUMENT TYPE PART	
 Open Source Ecology e.V. Knobelsdorffstr. 22 14059 Berlin www.ose-germany.de +49 (0) 30 / 92282426		LICENSE CERN-OHL		FILE NAME bearingB.ipt	
		SCALE 2 : 1		MATERIAL STEEL C45	
		VERSION 1.0		QUANTITY 1	
		SHEET 17		DATE 9/10/2020	

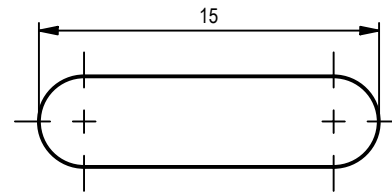
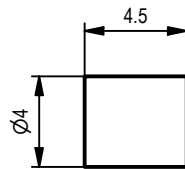
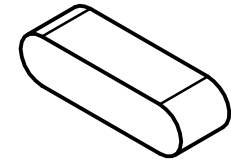



PROJECT PLATE ROLLING MACHINE		CREATED BY A. PARDO		APPROVED BY D. JAEGER		
PART NAME CRADLE		PART CODE 1.14	DOCUMENT TYPE PART		MATERIAL STEEL C45	
 <p>Open Source Ecology e.V. Knobelsdorffstr. 22 14059 Berlin www.ose-germany.de +49 (0) 30 / 92282426</p>		LICENSE CERN-OHL	FILE NAME CRADLE.ipt		VERSION 1.0	QUANTITY 1
			SCALE 3 : 1	SHEET 18	DATE 10/10/2020	

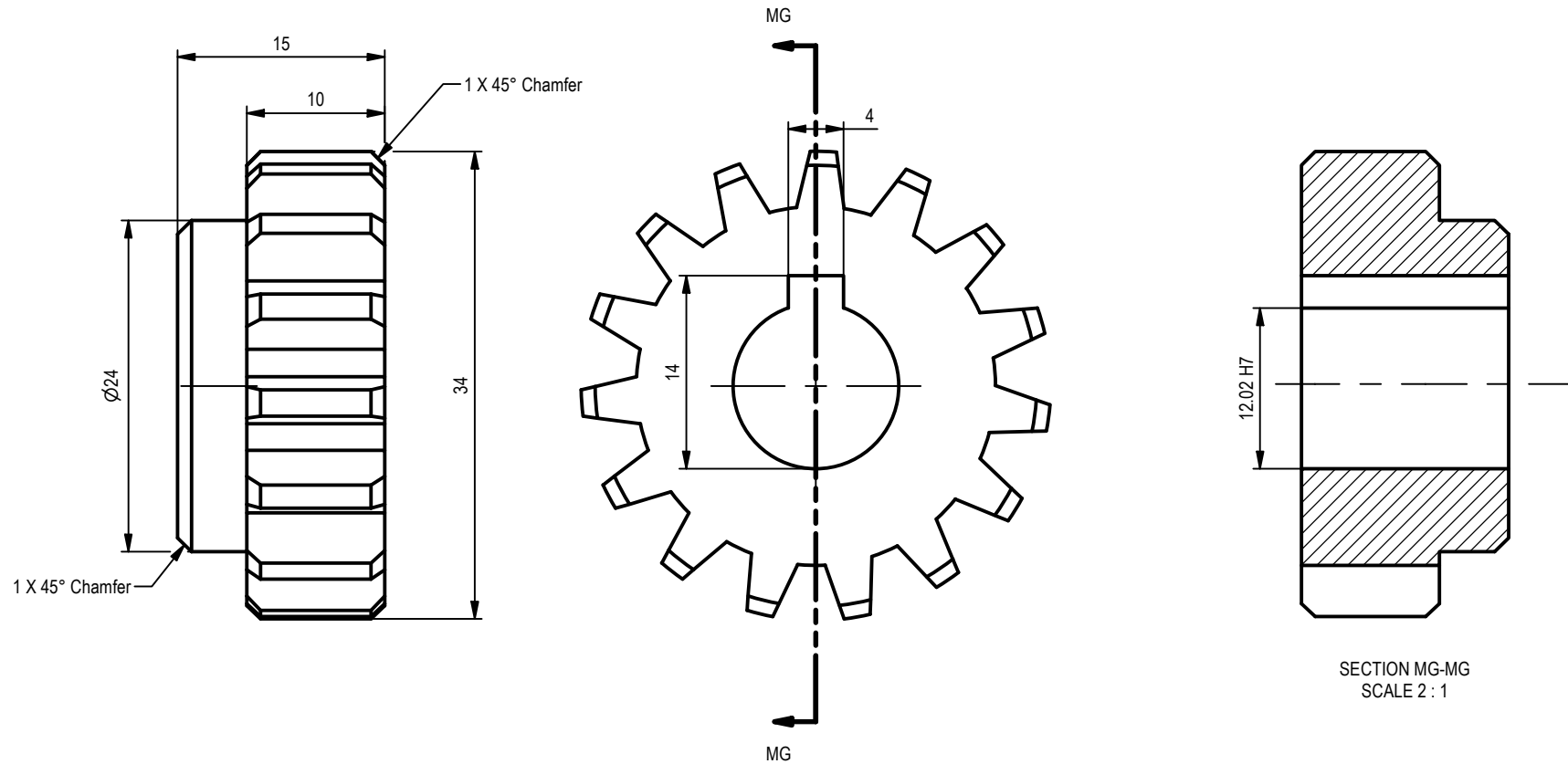

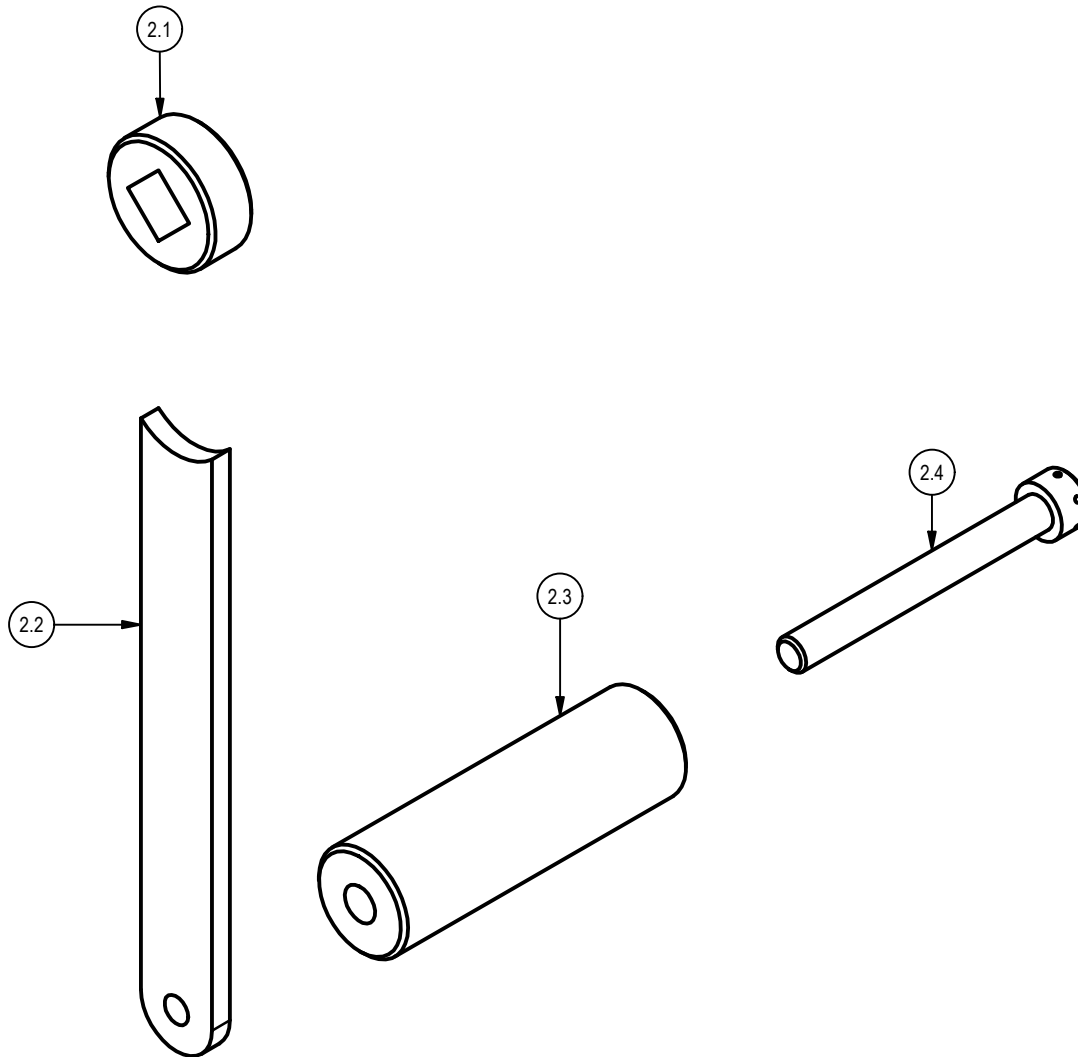

PROJECT <b>PLATE ROLLING MACHINE</b>	CREATED BY <b>A. PARDO</b>	APPROVED BY <b>D. JAEGER</b>		
PART NAME <b>GEAR</b>	PART CODE <b>1.15</b>	DOCUMENT TYPE <b>PART</b>	MATERIAL <b>STEEL C45</b>	
<p>Open Source Ecology e.V. Knobelsdorffstr. 22 14059 Berlin www.ose-germany.de +49 (0) 30 / 92282426</p>	LICENSE <b>CERN-OHL</b>	FILE NAME <b>gear.ipt</b>	VERSION <b>1.0</b>	QUANTITY <b>1</b>
		SCALE <b>2 : 1</b>	SHEET <b>19</b>	DATE <b>10/10/2020</b>



PROJECT PLATE ROLLING MACHINE		CREATED BY A. PARDO		APPROVED BY D. JAEGER		
PART NAME CRANK HANDLE		PART CODE 2	DOCUMENT TYPE ASSEMBLY		MATERIAL STEEL METAL / WOOD	
 <p>Open Source Ecology e.V. Knobelsdorffstr. 22 14059 Berlin www.ose-germany.de +49 (0) 30 / 92282426</p>		LICENSE CERN-OHL	FILE NAME CRANK HANDLE.iam		VERSION 1.0	QUANTITY 1
			SCALE 1 / 1.5	SHEET 20	DATE 10/10/2020	

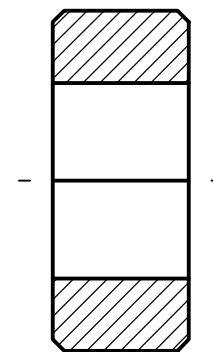
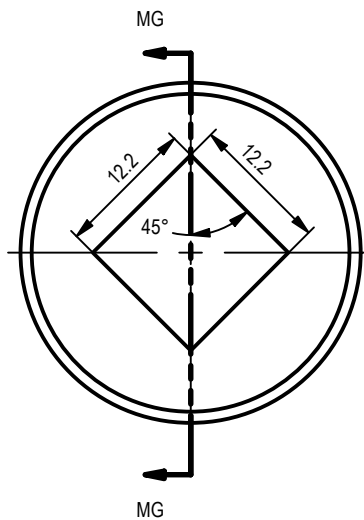
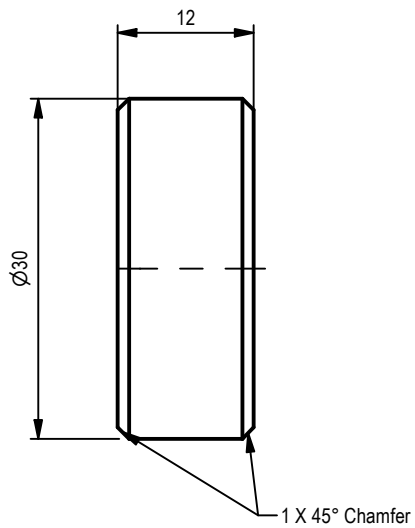

SECTION MG-MG  
SCALE 1.5 : 1

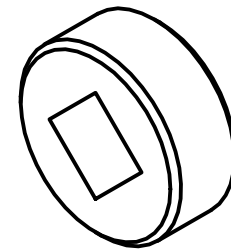

PROJECT PLATE ROLLING MACHINE	CREATED BY A. PARDO	APPROVED BY D. JAEGER		
PART NAME crank handle1	PART CODE 2.1	DOCUMENT TYPE PART	MATERIAL STEEL C45	
 <p>Open Source Ecology e.V. Knobelsdorffstr. 22 14059 Berlin www.os-e-germany.de +49 (0) 30 / 92282426</p>	LICENSE CERN-OHL	FILE NAME crank handle1.ipt	VERSION 1.0	QUANTITY 1
		SCALE 1.5 : 1	SHEET 21	DATE 10/10/2020

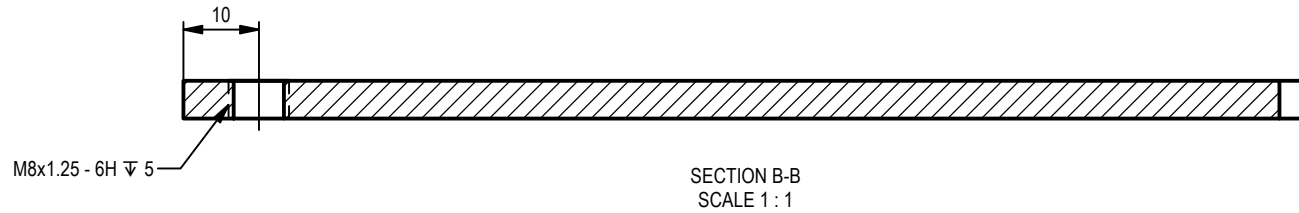
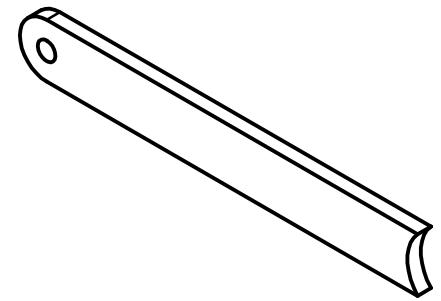

PROJECT PLATE ROLLING MACHINE		CREATED BY A. PARDO		APPROVED BY D. JAEGER	
PART NAME		PART CODE 2.2		DOCUMENT TYPE PART	
 Open Source Ecology e.V. Knobelsdorffstr. 22 14059 Berlin www.ose-germany.de +49 (0) 30 / 92282426		LICENSE CERN-OHL		MATERIAL STEEL C45	
		FILE NAME crank handle2.ipt		VERSION 1.0	
		SCALE 1:1		SHEET 22	DATE 10/10/2020

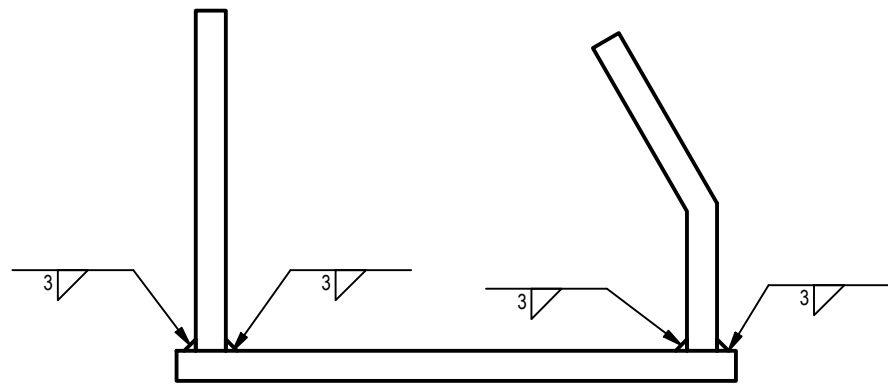
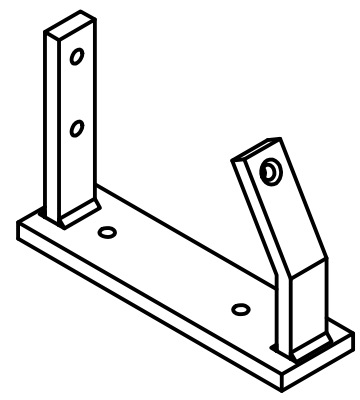
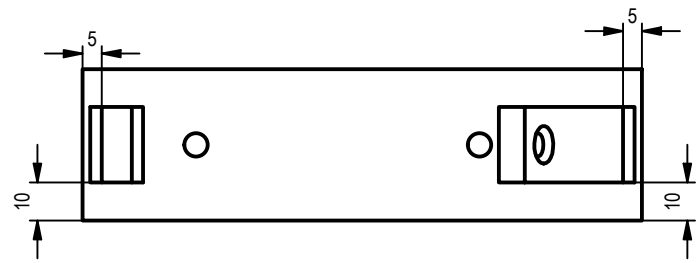

PROJECT PLATE ROLLING MACHINE	CREATED BY A. PARDO	APPROVED BY D. JAEGER		
PART NAME	PART CODE 3	DOCUMENT TYPE ASSEMBLY	MATERIAL STEEL METAL	
 <p>Open Source Ecology e.V Knobelsdorffstr. 22 14059 Berlin www.ose-germany.de +49 (0) 30 / 92282426</p>	LICENSE CERN-OHL	FILE NAME position.iam	VERSION 1.0	QUANTITY 1
		SCALE 1 / 2	SHEET 24	DATE 10/10/2020

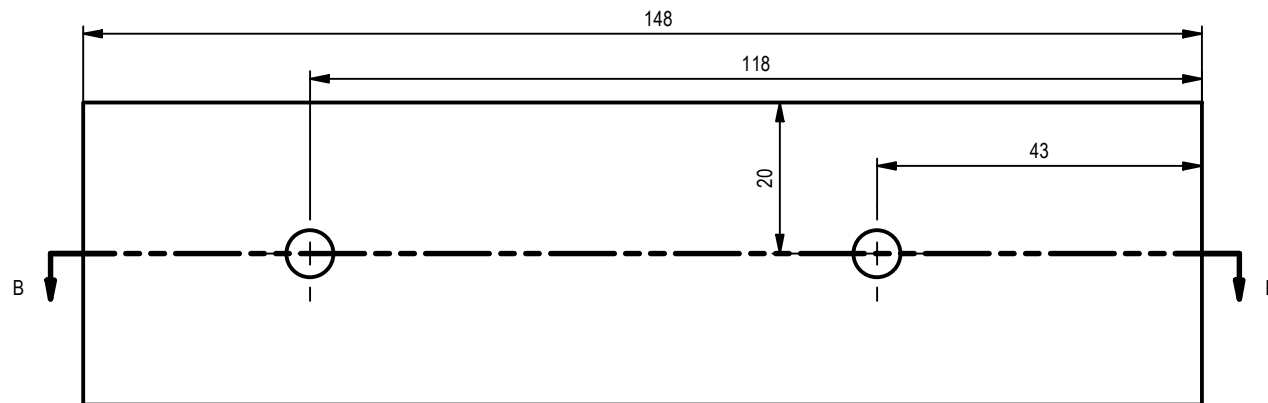
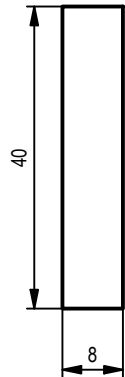
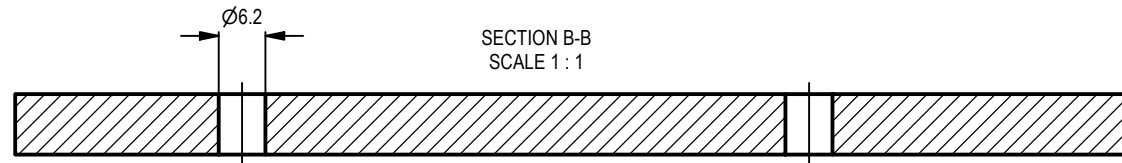
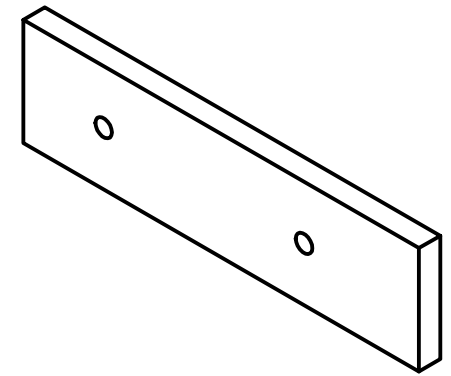

PROJECT PLATE ROLLING MACHINE	CREATED BY A. PARDO	APPROVED BY D. JAEGER		
PART NAME	PART CODE 3.1	DOCUMENT TYPE PART	MATERIAL STEEL C45	
 Open Source Ecology e.V. Knobelsdorffstr. 22 14059 Berlin www.os-e-germany.de +49 (0) 30 / 92282426	LICENSE CERN-OHL	FILE NAME position 1A.ipt	VERSION 1.0	QUANTITY 1
		SCALE 1:1	SHEET 25	DATE 10/10/2020

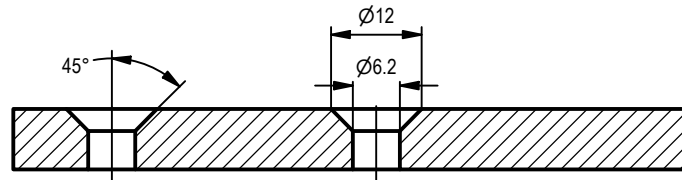
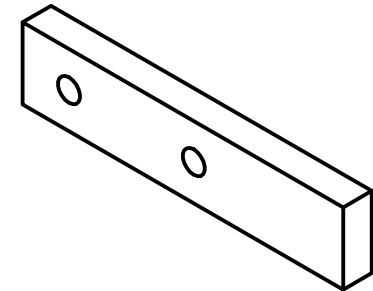

SECTION B-B  
SCALE 1 : 1

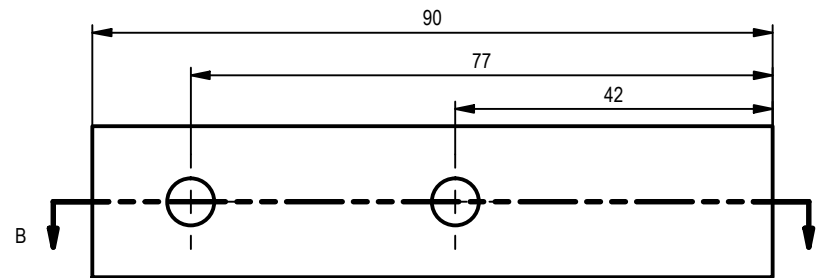
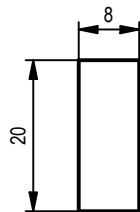

PROJECT PLATE ROLLING MACHINE	CREATED BY A. PARDO	APPROVED BY D. JAEGER		
PART NAME	PART CODE 3.2	DOCUMENT TYPE PART	MATERIAL STEEL C45	
 Open Source Ecology e.V. Knobelsdorffstr. 22 14059 Berlin <a href="http://www.ose-germany.de">www.ose-germany.de</a> +49 (0) 30 / 92282426	LICENSE CERN-OHL	FILE NAME position 1B.ipt	VERSION 1.0	QUANTITY 1
		SCALE 1 : 1	SHEET 26	DATE 10/10/2020

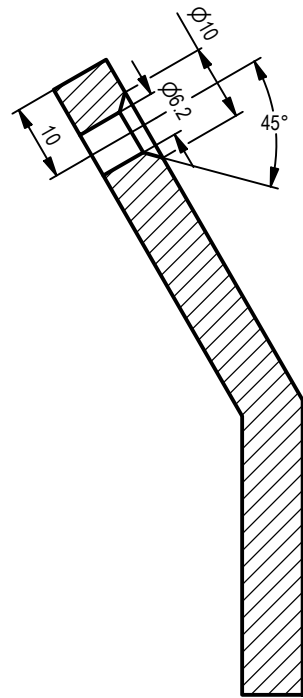
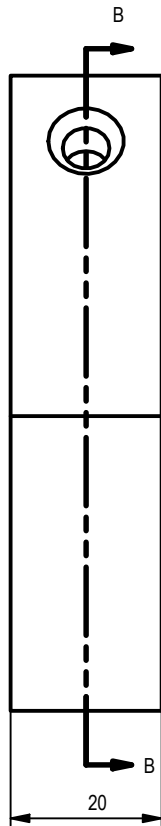

SECTION B-B  
SCALE 1 : 1

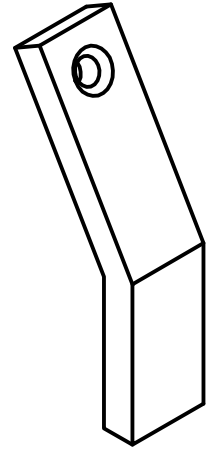
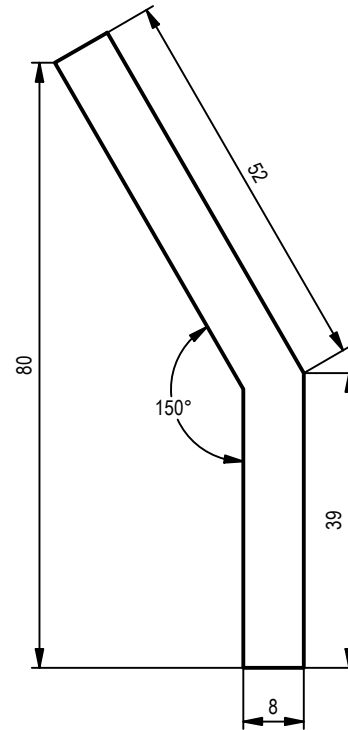

PROJECT PLATE ROLLING MACHINE		CREATED BY A. PARDO		APPROVED BY D. JAEGER	
PART NAME		PART CODE 3.3		DOCUMENT TYPE PART	
 Open Source Ecology e.V. Knobelsdorffstr. 22 14059 Berlin www.ose-germany.de +49 (0) 30 / 92282426		LICENSE CERN-OHL		FILE NAME position 1C.ipt	
		SCALE 1 : 1		MATERIAL STEEL C45	
		VERSION 1.0		QUANTITY 1	
		SHEET 27		DATE 10/10/2020	