

Note: All units in mm.

PROJECT	CREATED BY	APPROVED BY	DATE	VERSION
Wood router table - size 560 mm	J. Zeron	A. Morillo	14/10/2021	1.0
PART NAME	FILE NAME			POS
3D views	Wood router table - size 560 mm.iam			A1
PUBLISHED BY		DOC. TYPE	MATERIAL	QUANTITY
OHO e.V.		Assembly		1
		LICENCE	SCALE	SHEET
		CC-BY-SA 4.0	1:8	1 /22

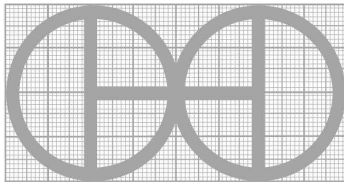
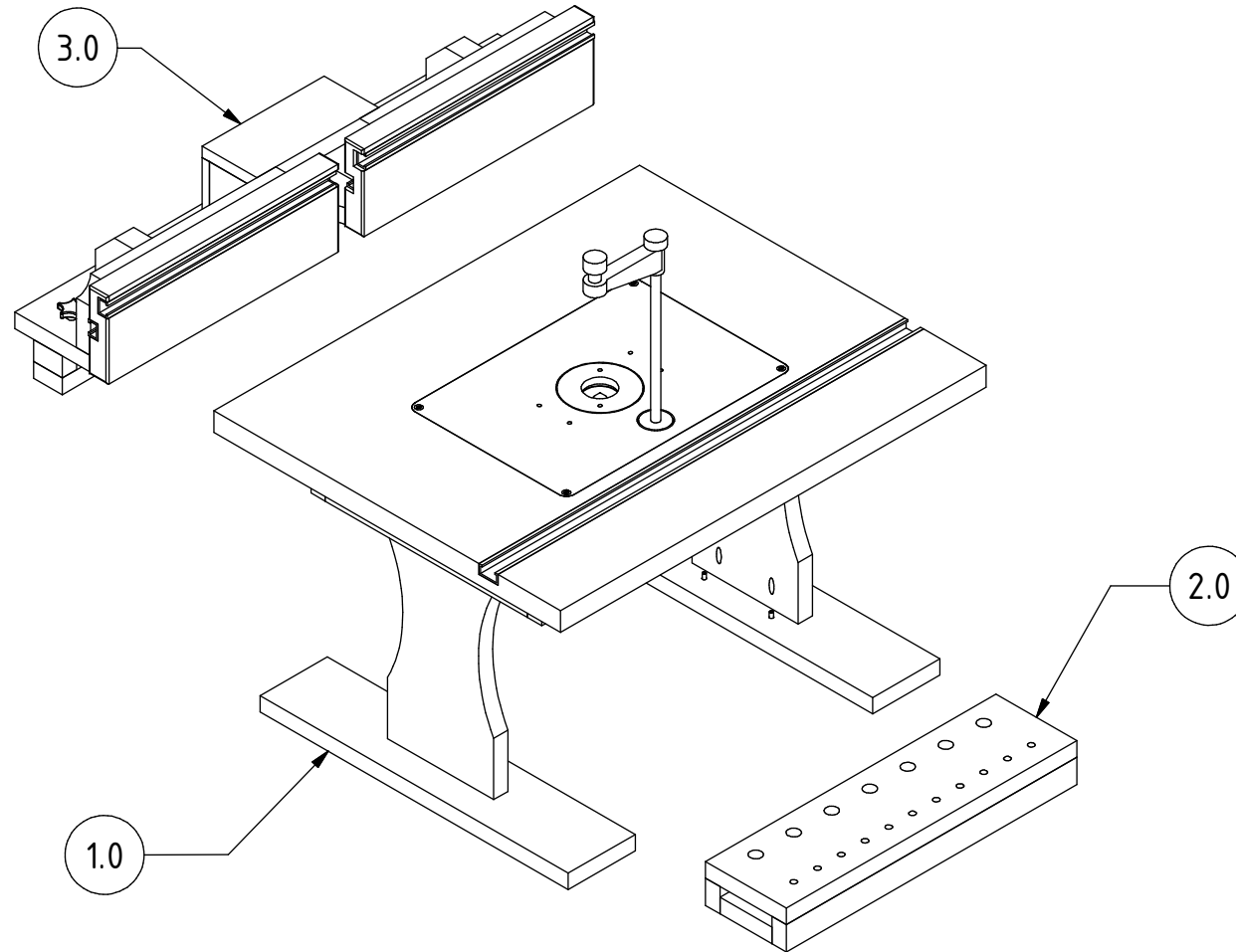
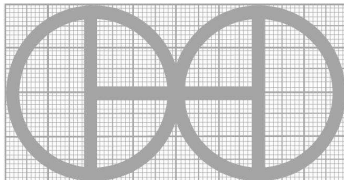

PROJECT	CREATED BY	APPROVED BY	DATE	VERSION
Wood router table - size 560 mm	J. Zeron	A. Morillo	14/10/2021	1.0
PART NAME	FILE NAME			POS
Exploded 3D view	Wood router table - size 560 mm.ipn			A2
PUBLISHED BY		DOC. TYPE	MATERIAL	QUANTITY
OHO e.V.		Assembly		1
		LICENCE	SCALE	SHEET
		CC-BY-SA 4.0	1:7	2 /22

## Parts list

POS	QTY	PART NAME	FILE NAME	PART TYPE	SPECIFICATIONS	SHEET
A1	1	3d views	Wood router table - size 560 mm.iam	-	-	1
A2	1	Exploded 3d view	Wood router table - size 560 mm.ipn	-	-	2
B1	-	Parts list	Wood router table - size 560 mm.csv	-	-	3-4
C1	-	Technical notes	-	-	-	5
1.0	-	Router table	Router table.ipn	-	-	6
1.1	1	Top	Top.ipt	Production	Hardwood 25mm	7
1.2	2	Front-back	Front-back.ipt	Production	Hardwood 19mm	8
1.3	2	Ends	Ends.ipt	Production	Hardwood 19mm	9
1.4	2	Leg	Leg.ipt	Production	Hardwood 19mm	10
1.5	2	Feet	Feet.ipt	Production	Hardwood 19mm	11
1.6	1	Miter gauge A	-	Production	Miter gauge track aluminium 25x13x2x560mm	-
1.7	1	Router	-	Buy	<a href="https://www.amazon.com/dp/B079YY98N1/?tag=best-router-table-20&amp;asc_source=browser&amp;asc_refurl=https://www.bobvila.com/articles/best-router-table#video-inmersive-view_1634098773396">https://www.amazon.com/dp/B079YY98N1/?tag=best-router-table-20&amp;asc_source=browser&amp;asc_refurl=https://www.bobvila.com/articles/best-router-table#video-inmersive-view_1634098773396</a>	-
1.8	20	Screw A	-	Standard	DIN 2009 M6x25mm	-
1.9	4	Screw B	-	Standard	DIN 2009 M4x25mm	-
2.0	-	Organizer	Organizer.ipn	-	-	12
2.1	1	Bottom organizer	-	Production	Hardwood 19x68x382mm	-
2.2	2	Side organizer	-	Production	Hardwood 19x31x382mm	-
2.3	1	Top organizer	Top organizer.ipt	Production	Hardwood 19x106x382mm	13
2.4	10	Join A	-	Buy	Galvanized nails 1.8x35mm	-
3.0	-	Fence	Fence.ipn	-	-	14
3.1	1	Fence base	Fence base.ipt	Production	Hardwood 19mm	15
3.2	2	Fence plate	Fence plate.ipt	Production	Hardwood 19mm	16
3.3	2	Sliding fence plate	Sliding fence plate.ipt	Production	Hardwood 25mm	17
3.4	2	Miter gauge B	-	Production	Miter gauge track aluminium 19x13x2x301mm	-
3.5	2	Beveled fence	Beveled fence.ipt	Production	Hardwood 25mm	18
3.6	2	Square fence	-	Production	Hardwood 25x62x62mm	-
3.7	1	Rear vacuum box	Rear vacuum box.ipt	Production	Hardwood 19mm	19
3.8	1	Top vacuum box	Top vacuum box.ipt	Production	Hardwood 19mm	20

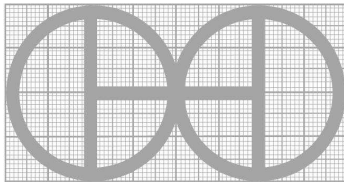
PROJECT	CREATED BY	APPROVED BY	DATE	VERSION
Wood router table - size 560 mm	J. Zeron	A. Morillo	14/10/2021	1.0
PART NAME	FILE NAME			POS
Parts list	Wood router table - size 560 mm.csv			B1
PUBLISHED BY		DOC. TYPE	MATERIAL	QUANTITY
OHO e.V.		Parts list		
		LICENCE	SCALE	SHEET
		CC-BY-SA 4.0		3 /22

Parts list

POS	QTY	PART NAME	FILE NAME	PART TYPE	SPECIFICATIONS	SHEET
3.9	14	Screw C	-	Standard	DIN 2009 M6x25mm	-
3.10	2	Ez-mount clamp riser A	Ez-mount clamp riser A.ipt	Production	Hardwood 19mm	21
3.11	2	Ez-mount clamp riser B	Ez-mount clamp riser B.ipt	Production	Hardwood 19mm	22
3.12	2	Dowel pin	-	Production	Steel C45 pin threaded D6x25mm	-
3.13	2	Stud A	-	Standard	DIN 835 M7x60mm	-
3.14	4	Washer	-	Standard	DIN 7349 M7	-
3.15	4	Nut	-	Standard	DIN 24035 M7	-
3.16	2	Knob A	-	Buy	Knob T-track plastic	-
3.17	2	Knob B	-	Buy	Knob T-track plastic	-
3.18	12	Join B	-	Buy	Galvanized nails 1.8x35mm	-

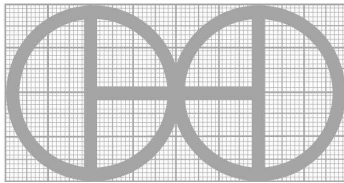
PROJECT	CREATED BY	APPROVED BY	DATE	VERSION
Wood router table - size 560 mm	J. Zeron	A. Morillo	14/10/2021	1.0
PART NAME	FILE NAME			POS
Parts list	Wood router table - size 560 mm.csv			B1
PUBLISHED BY		DOC. TYPE	MATERIAL	QUANTITY
OHO e.V.		Parts list		
		LICENCE	SCALE	SHEET
		CC-BY-SA 4.0		4 /22

## TECHNICAL NOTES

NOTES	CONTENT
GENERAL NOTES	
Wood	<ul style="list-style-type: none"> <li>- The wood must be treated with pesticides and kiln-dried to ensure adequate humidity.</li> <li>- Wood sealer should be applied for later use.</li> <li>- All wood pieces must be glued together with white glue before nailing and screwed.</li> </ul>

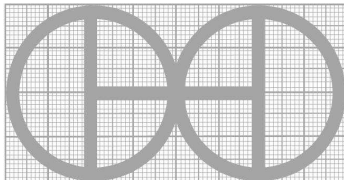
PROJECT	CREATED BY	APPROVED BY	DATE	VERSION
Wood router table - size 560 mm	J. Zeron	A. Morillo	14/10/2021	1.0
PART NAME	FILE NAME			POS
Technical notes				C1
PUBLISHED BY		DOC. TYPE	MATERIAL	QUANTITY
OHO e.V.		Technical notes		
		LICENCE	SCALE	SHEET
		CC-BY-SA 4.0		5 /22

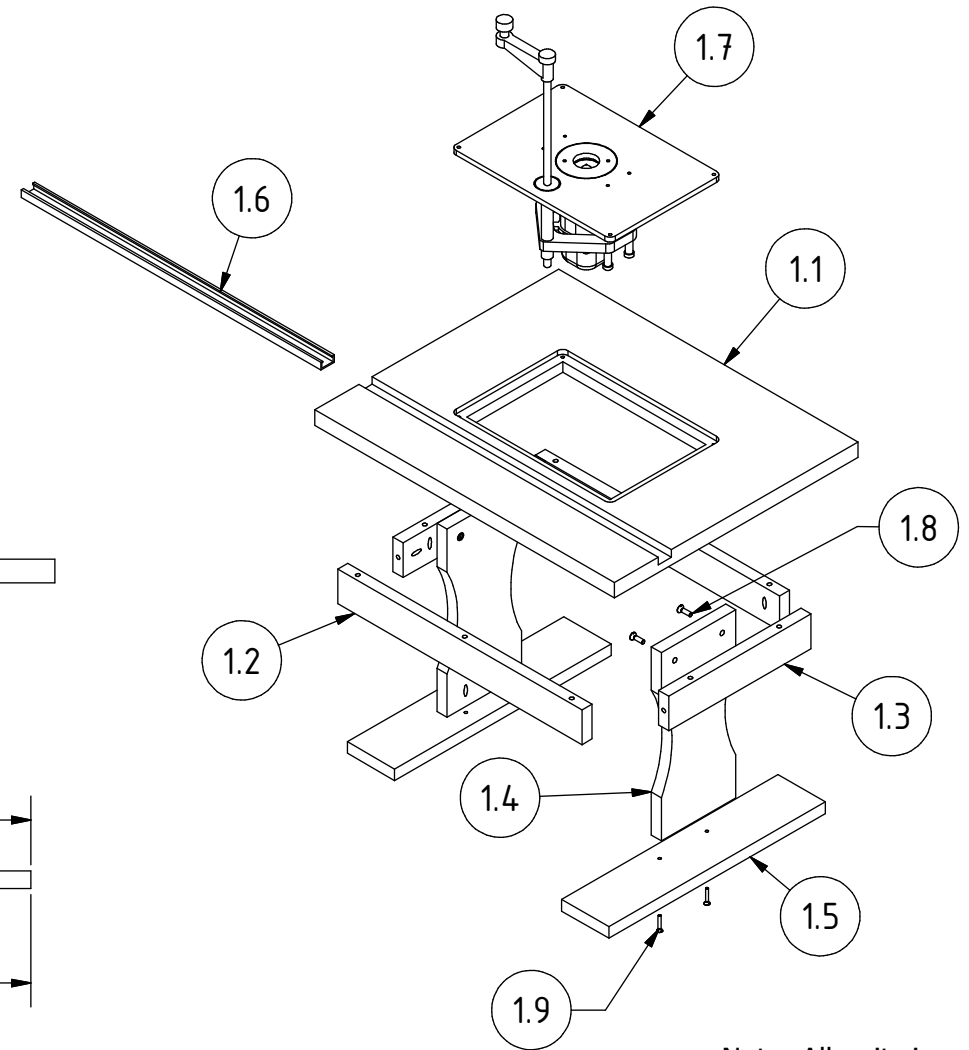
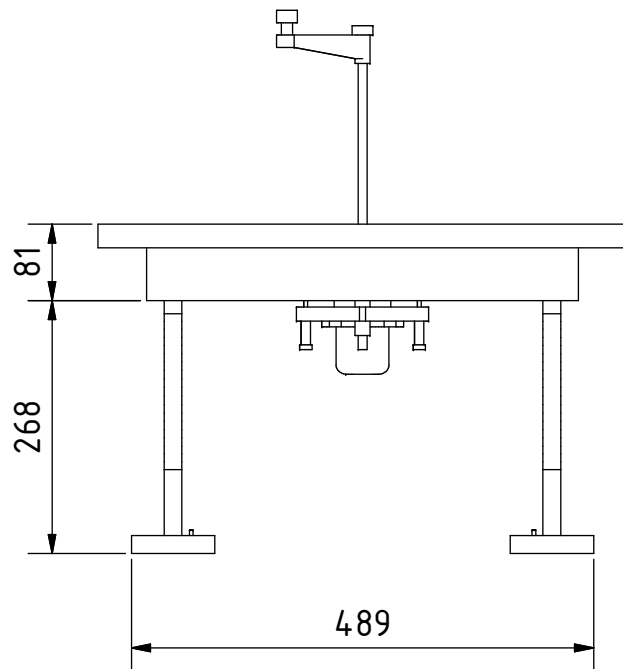
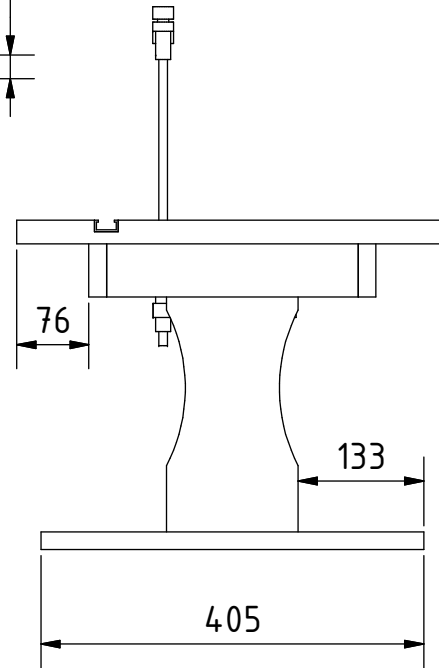
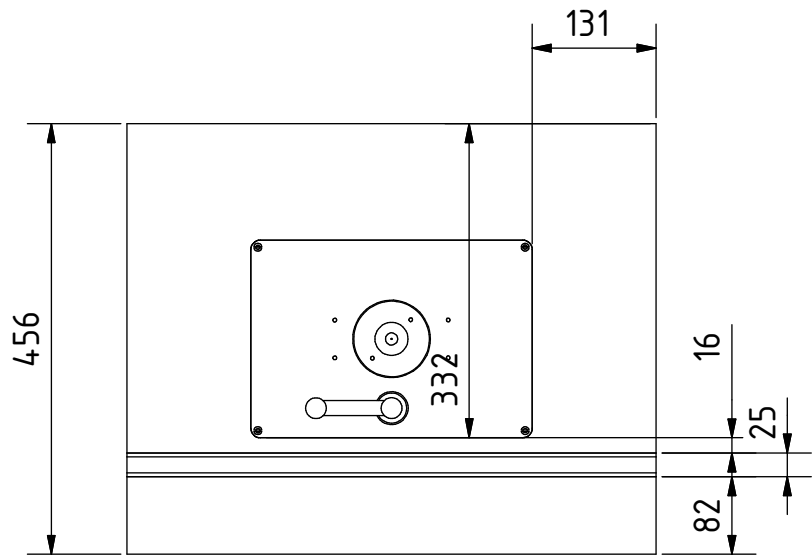

Note: All units in mm.

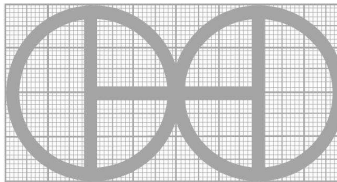
PROJECT	CREATED BY	APPROVED BY	DATE	VERSION
Wood router table - size 560 mm	J. Zeron	A. Morillo	14/10/2021	1.0
PART NAME	FILE NAME			POS
Router table	Router table.ipn			1.0
PUBLISHED BY		DOC. TYPE	MATERIAL	QUANTITY
OHO e.V.		Assembly		1
		LICENCE	SCALE	SHEET
		CC-BY-SA 4.0	1:30	6 /22

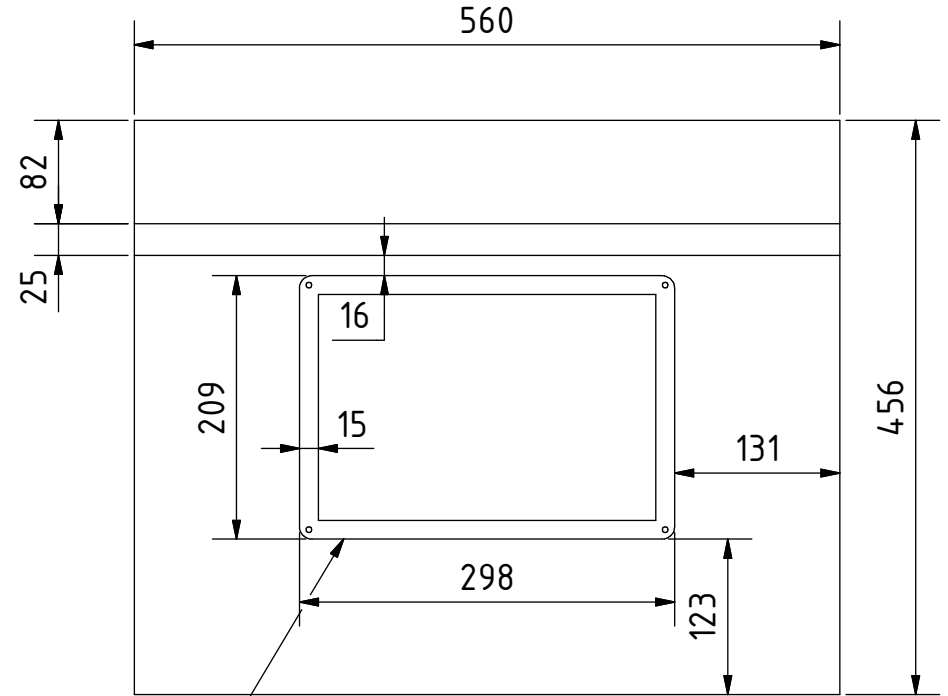
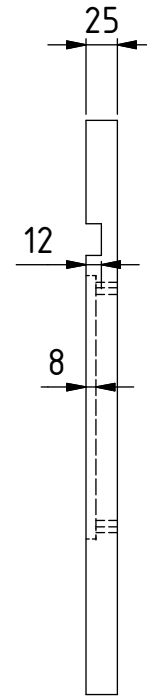
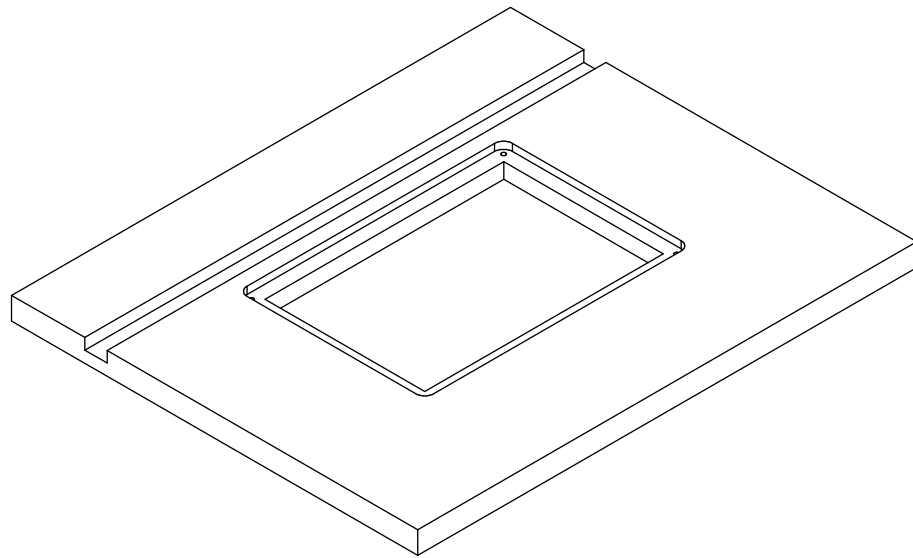

Opening dimensions will depend on the plate of the Router

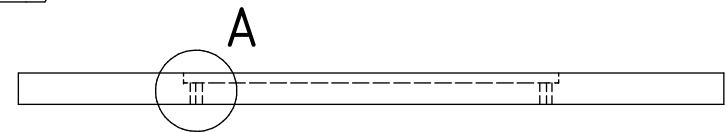

A ( 1 : 1 )

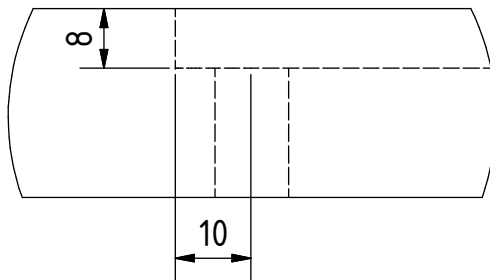

Note: All units in mm.

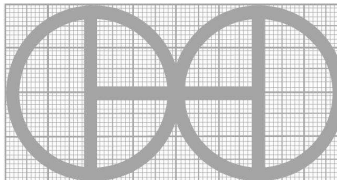
PROJECT	CREATED BY	APPROVED BY	DATE	VERSION
Wood router table - size 560 mm	J. Zeron	A. Morillo	14/10/2021	1.0
PART NAME	FILE NAME			POS
Top	Top.ipt			1.1
PUBLISHED BY		DOC. TYPE	MATERIAL	QUANTITY
OHO e.V.		Part	Hardwood	1
		LICENCE	SCALE	SHEET
		CC-BY-SA 4.0	1:6	7 /22

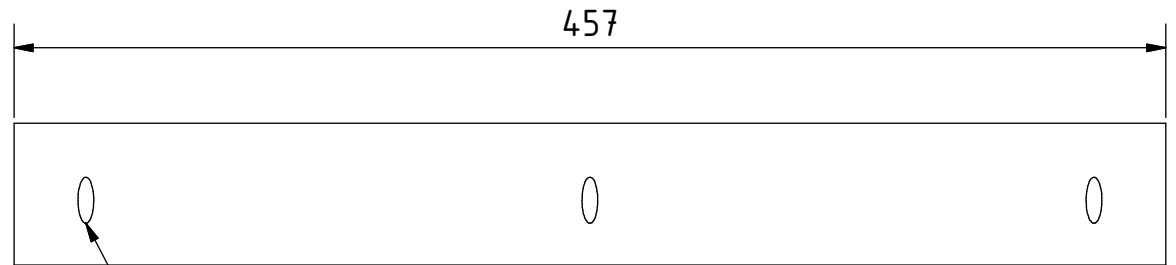
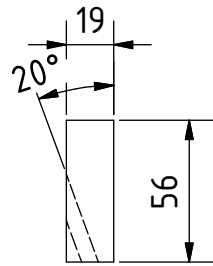

Drill the pocket holes  
6mm x 3

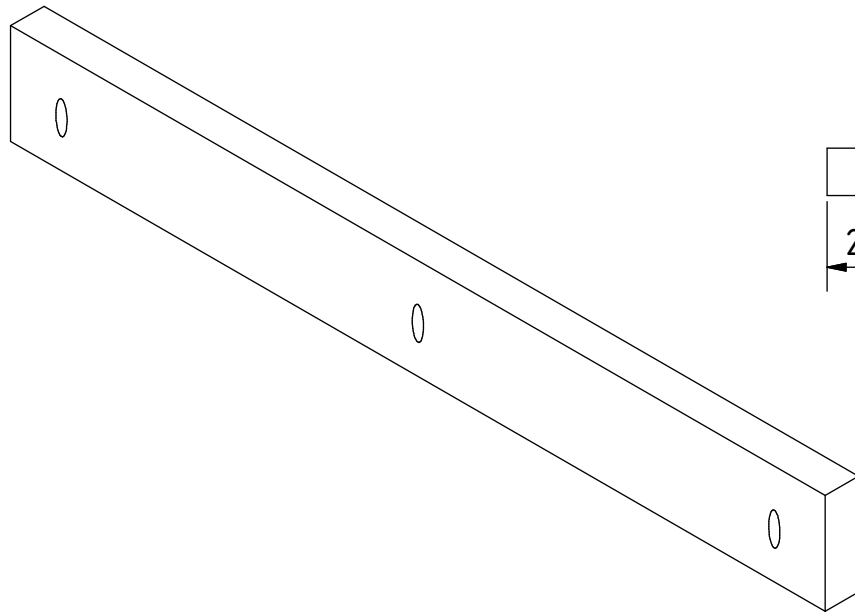
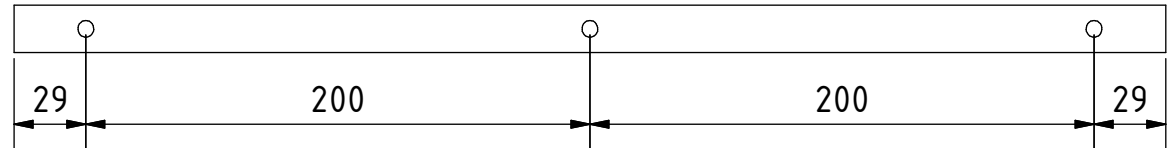

Note: All units in mm.

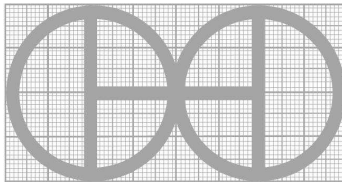
PROJECT	CREATED BY	APPROVED BY	DATE	VERSION
Wood router table - size 560 mm	J. Zeron	A. Morillo	14/10/2021	1.0
PART NAME	FILE NAME			POS
Front-back	Front-back.ipt			1.2
PUBLISHED BY		DOC. TYPE	MATERIAL	QUANTITY
OHO e.V.		Part	Hardwood	2
		LICENCE	SCALE	SHEET
		CC-BY-SA 4.0	1:3	8 /22



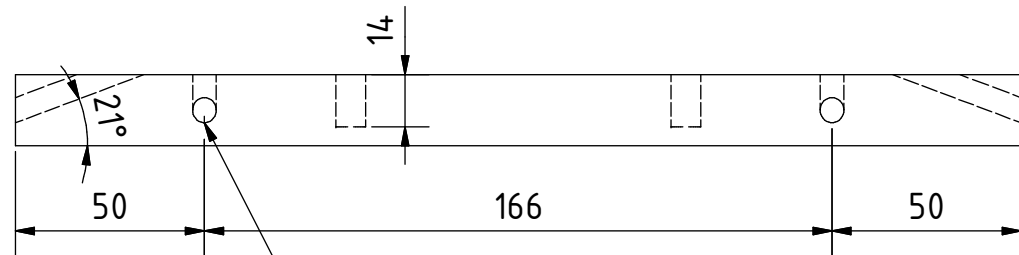
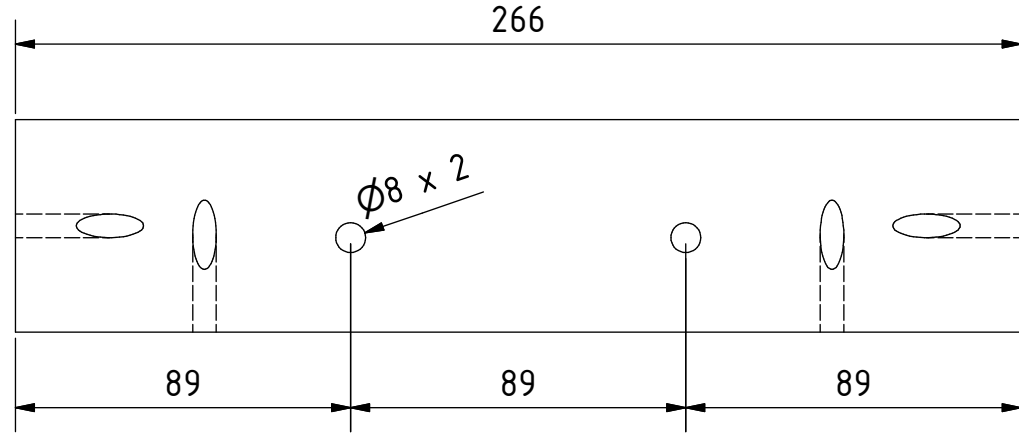
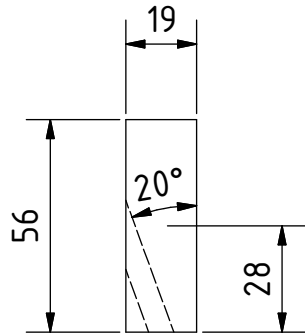

Drill the pocket holes  
6mm x 4

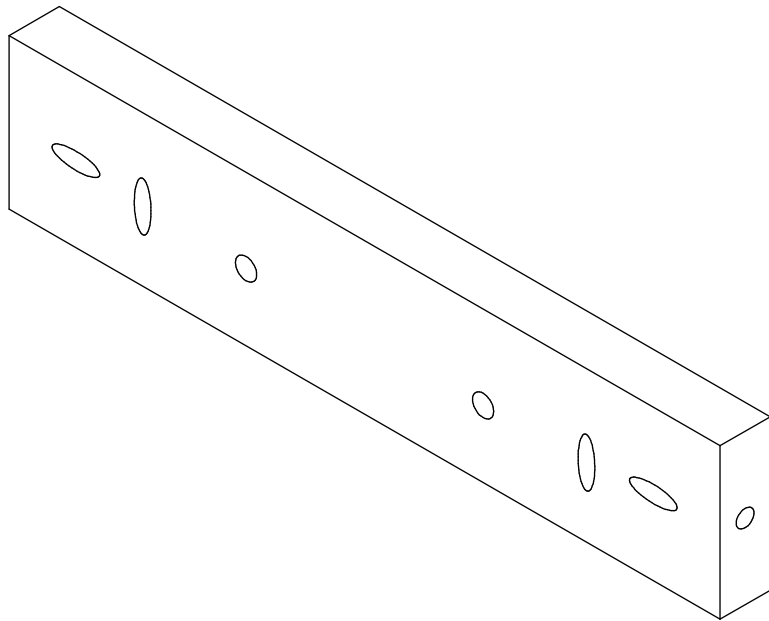

Note: All units in mm.

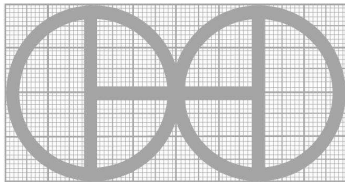
PROJECT	CREATED BY	APPROVED BY	DATE	VERSION
Wood router table - size 560 mm	J. Zeron	A. Morillo	14/10/2021	1.0
PART NAME	FILE NAME			POS
Ends	Ends.ipt			1.3
PUBLISHED BY		DOC. TYPE	MATERIAL	QUANTITY
OHO e.V.		Part	Hardwood	2
		LICENCE	SCALE	SHEET
		CC-BY-SA 4.0	1:2	9 /22

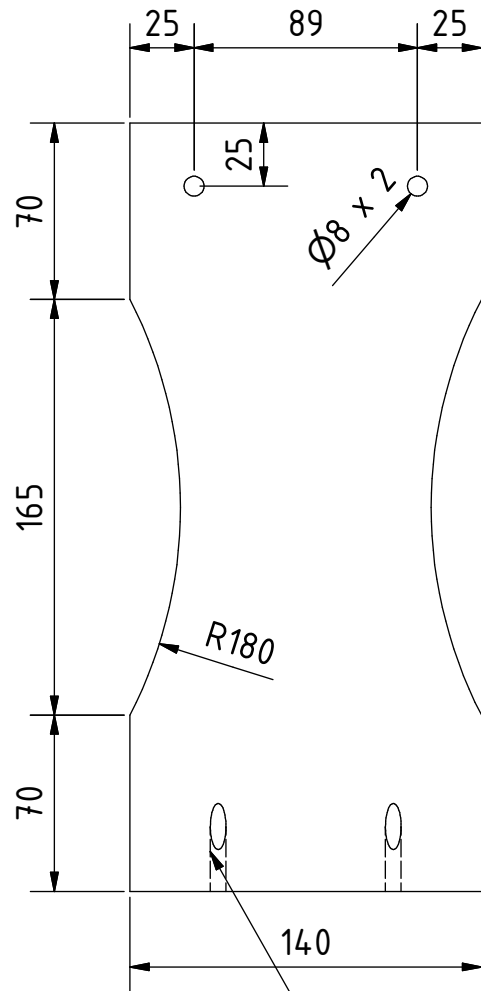

Drill the pocket holes  
6mm x 2

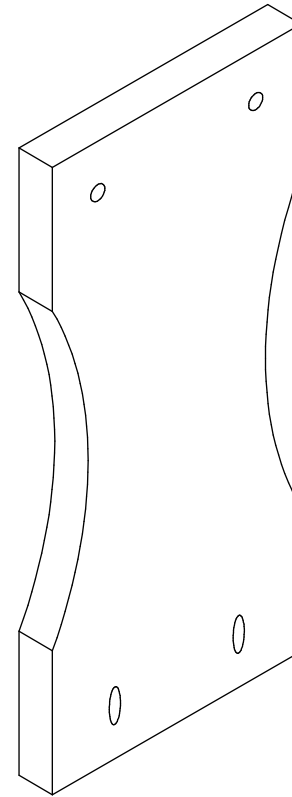
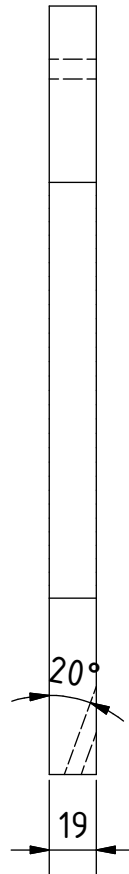
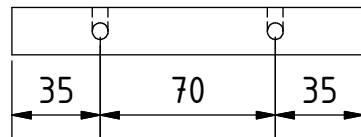

Note: All units in mm.

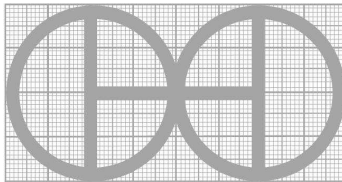
PROJECT	CREATED BY	APPROVED BY	DATE	VERSION
Wood router table - size 560 mm	J. Zeron	A. Morillo	14/10/2021	1.0
PART NAME	FILE NAME			POS
Leg	Leg.ipt			1.4
PUBLISHED BY		DOC. TYPE	MATERIAL	QUANTITY
OHO e.V.		Part	Hardwood	2
		LICENCE	SCALE	SHEET
		CC-BY-SA 4.0	1:3	10 /22

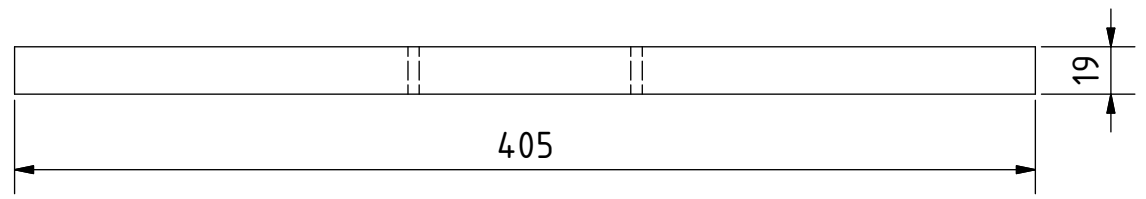
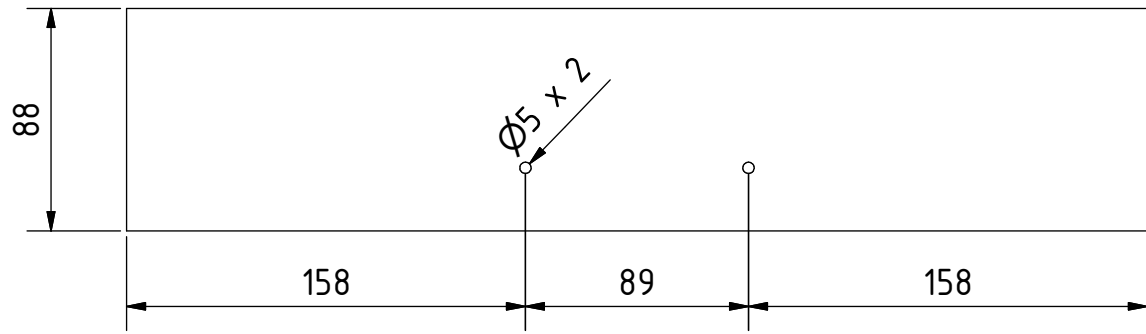
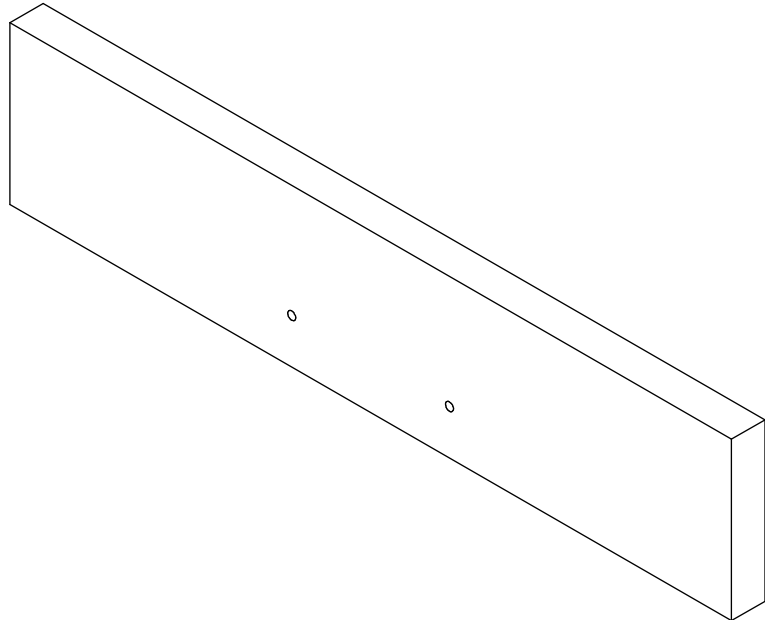

Note: All units in mm.

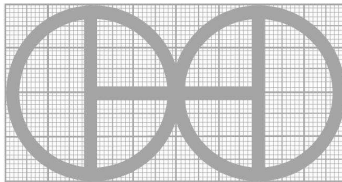
PROJECT	CREATED BY	APPROVED BY	DATE	VERSION
Wood router table - size 560 mm	J. Zeron	A. Morillo	14/10/2021	1.0
PART NAME	FILE NAME			POS
Feet	Feet.ipt			1.5
PUBLISHED BY		DOC. TYPE	MATERIAL	QUANTITY
OHO e.V.		Part	Hardwood	2
		LICENCE	SCALE	SHEET
		CC-BY-SA 4.0	1:3	11 /22

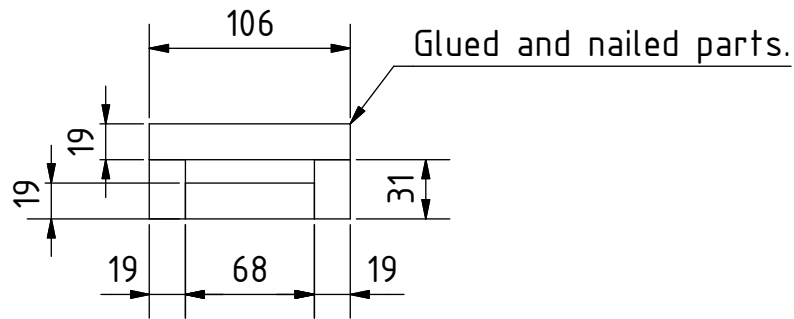
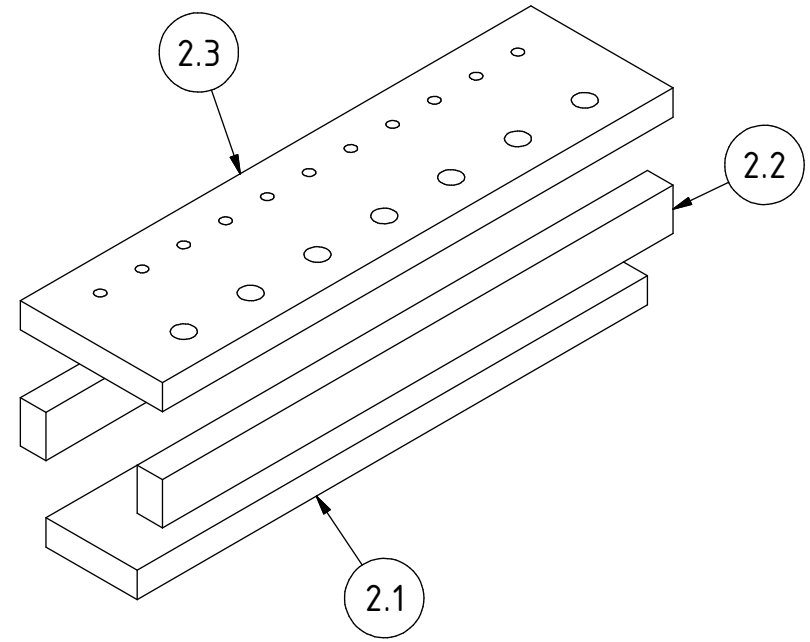
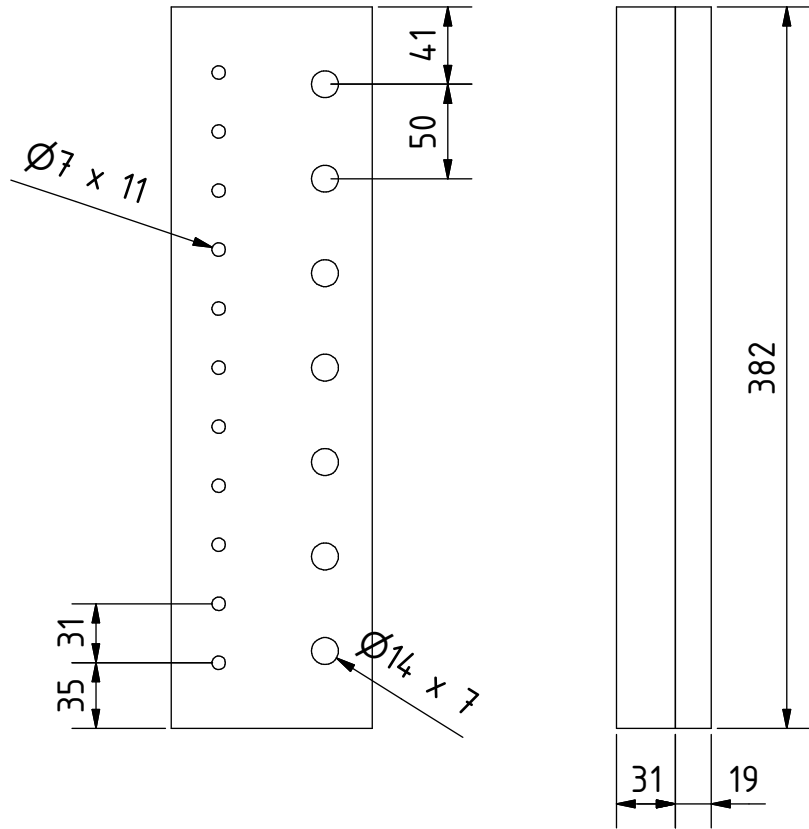

Note: All units in mm.

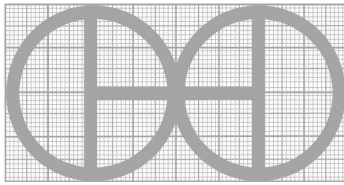
PROJECT	CREATED BY	APPROVED BY	DATE	VERSION
Wood router table - size 560 mm	J. Zeron	A. Morillo	14/10/2021	1.0
PART NAME	FILE NAME			POS
Organizer	Organizer.ipn			2.0
PUBLISHED BY		DOC. TYPE	MATERIAL	QUANTITY
OHO e.V.		Assembly		1
		LICENCE	SCALE	SHEET
		CC-BY-SA 4.0	1:4	12 /22

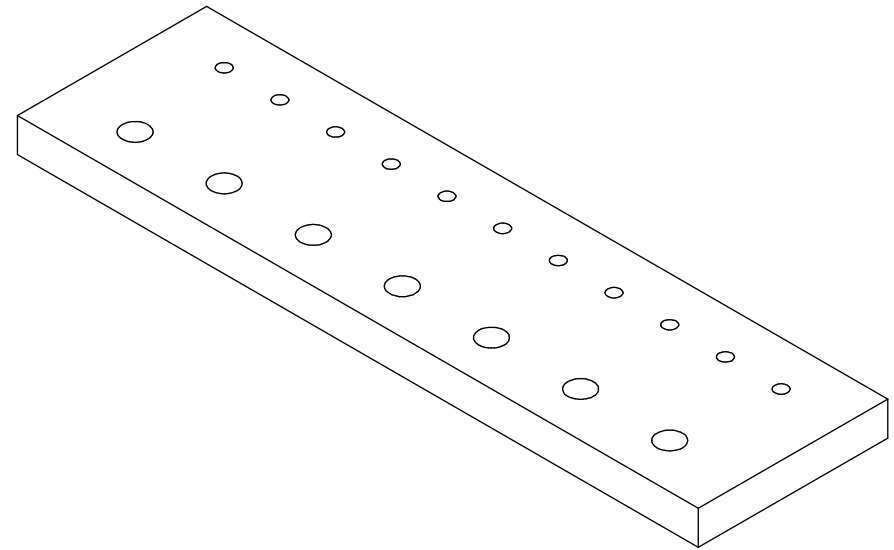
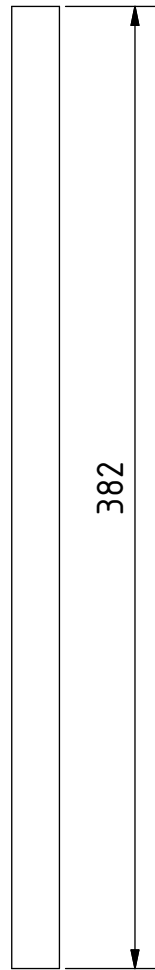
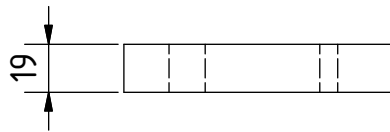
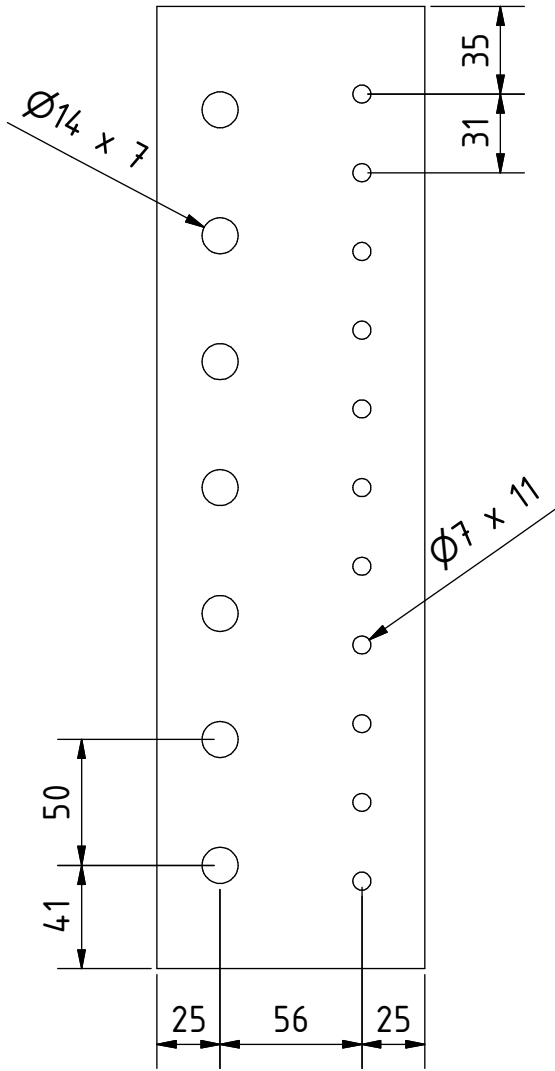

Note: All units in mm.

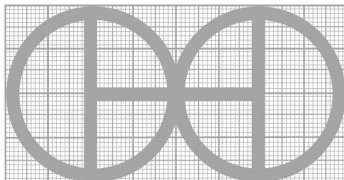
PROJECT	CREATED BY	APPROVED BY	DATE	VERSION
Wood router table - size 560 mm	J. Zeron	A. Morillo	14/10/2021	1.0
PART NAME	FILE NAME			POS
Top organizer	Top organizer.ipt			2.3
PUBLISHED BY		DOC. TYPE	MATERIAL	QUANTITY
OHO e.V.		Part	Hardwood	1
		LICENCE	SCALE	SHEET
		CC-BY-SA 4.0	1:3	13 /22

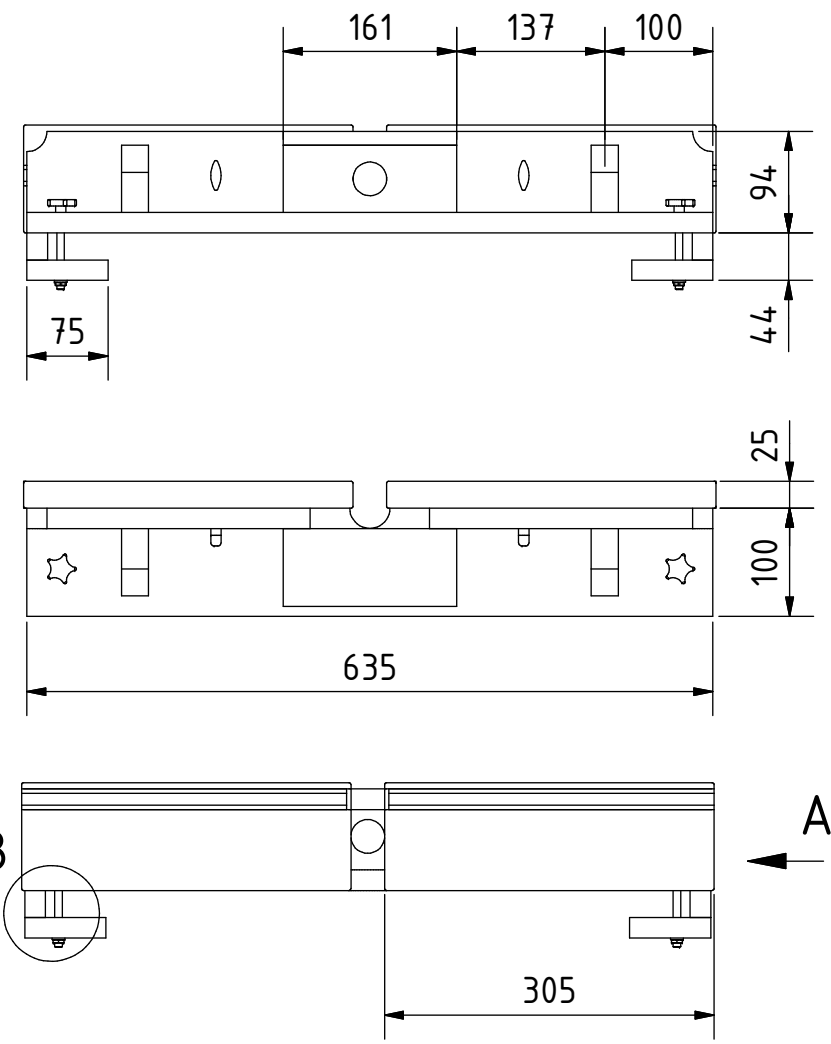
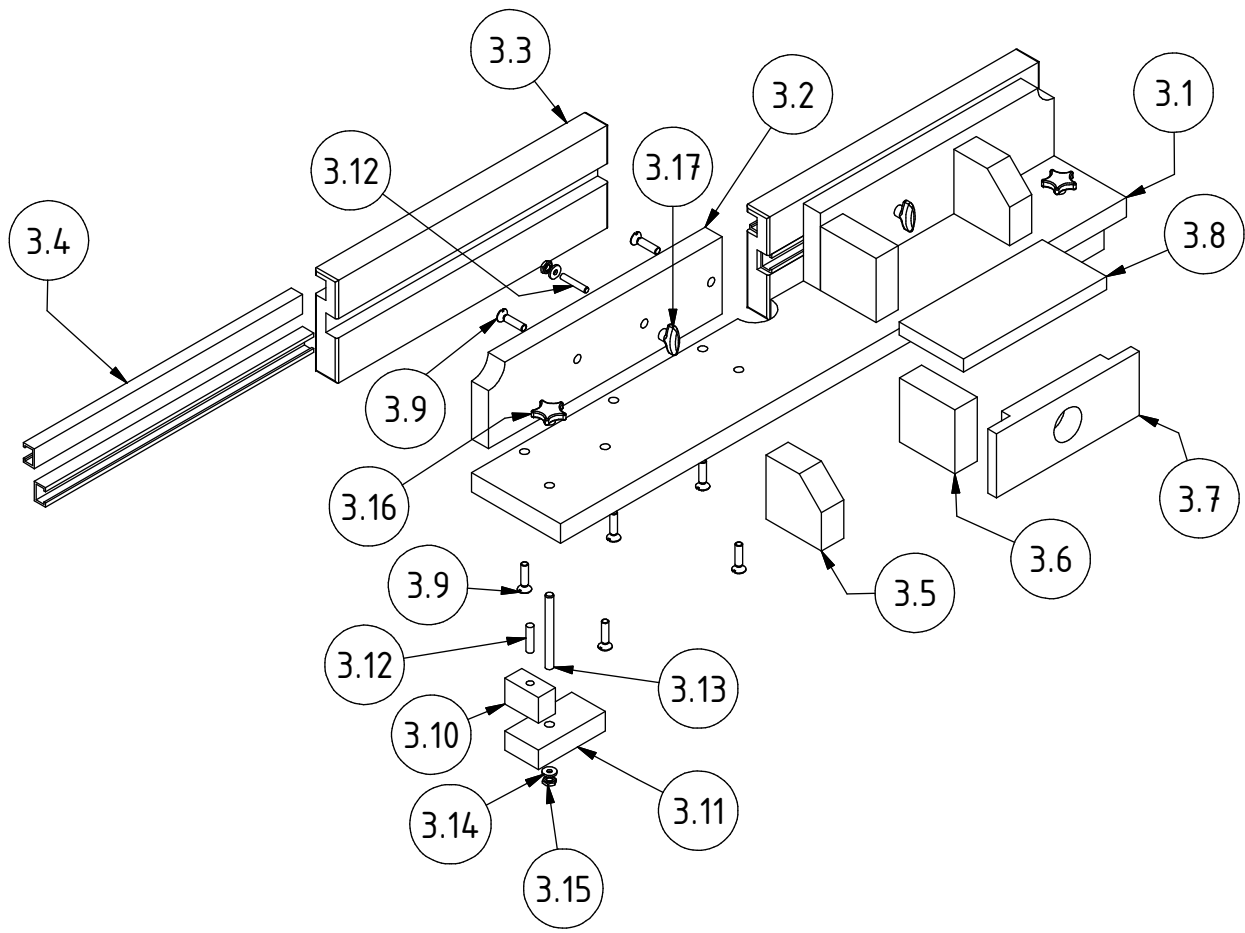

A ( 1 : 3 )

B ( 1 : 2 )

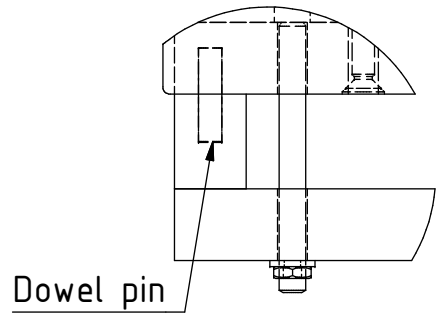
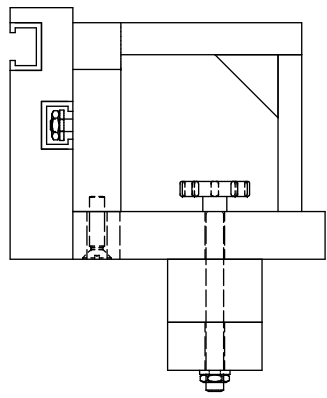

Dowel pin

Note: All units in mm.

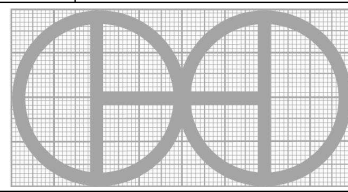
PROJECT	CREATED BY	APPROVED BY	DATE	VERSION
Wood router table - size 560 mm	J. Zeron	A. Morillo	14/10/2021	1.0
PART NAME	FILE NAME			POS
Fence	Fence.ipn			3.0
PUBLISHED BY		DOC. TYPE	MATERIAL	QUANTITY
OHO e.V.		Assembly		1
		LICENCE	SCALE	SHEET
		CC-BY-SA 4.0	1:7	14 /22

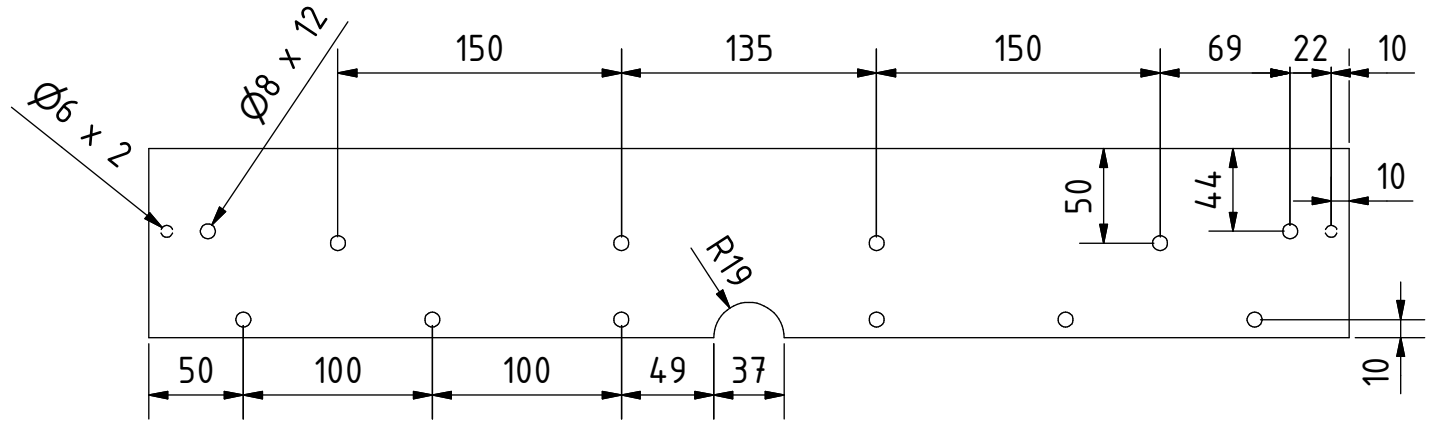
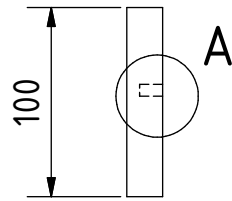

A ( 1 : 2 )

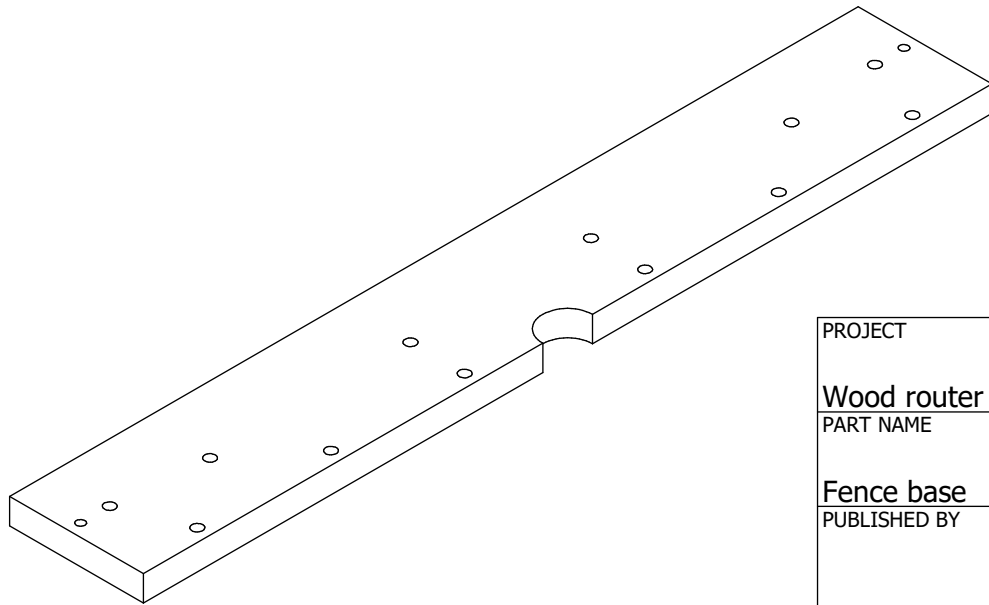
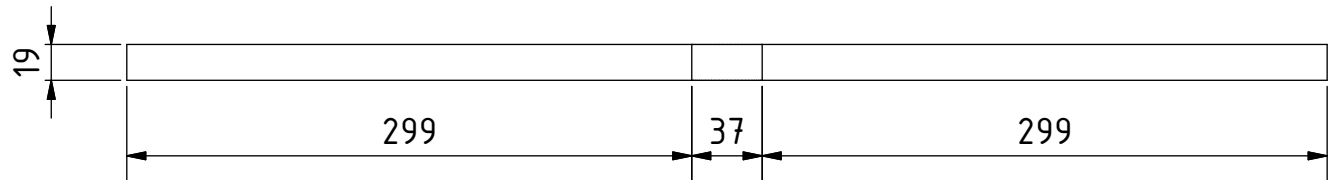
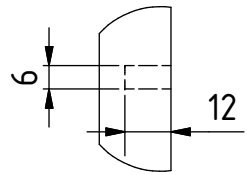

Note: All units in mm.

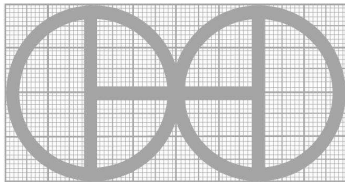
PROJECT	CREATED BY	APPROVED BY	DATE	VERSION
Wood router table - size 560 mm	J. Zeron	A. Morillo	14/10/2021	1.0
PART NAME	FILE NAME			POS
Fence base	Fence base.ipt			3.1
PUBLISHED BY		DOC. TYPE	MATERIAL	QUANTITY
		Part	Hardwood	1
		LICENCE	SCALE	SHEET
OHO e.V.		CC-BY-SA 4.0	1:4	15 /22

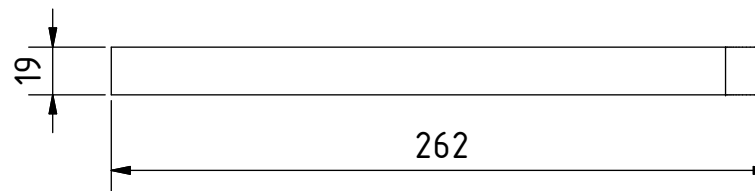
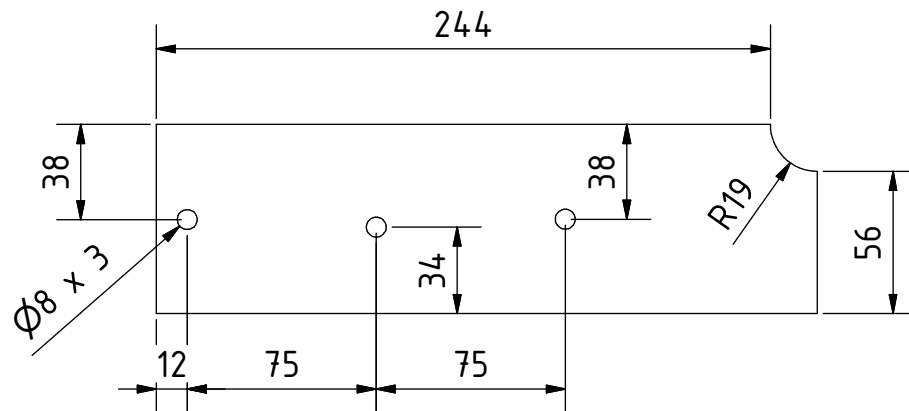
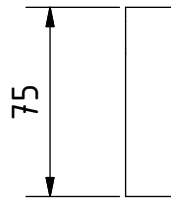
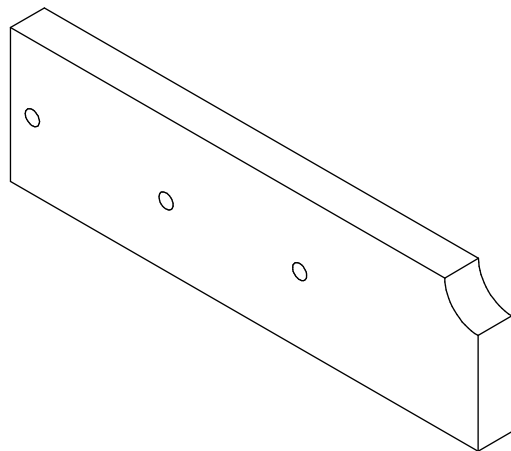

Note: All units in mm.

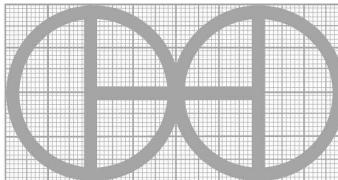
PROJECT	CREATED BY	APPROVED BY	DATE	VERSION
Wood router table - size 560 mm	J. Zeron	A. Morillo	14/10/2021	1.0
PART NAME	FILE NAME			POS
Fence plate	Fence plate.ipt			3.2
PUBLISHED BY		DOC. TYPE	MATERIAL	QUANTITY
OHO e.V.		Part	Hardwood	2
		LICENCE	SCALE	SHEET
		CC-BY-SA 4.0	1:3	16 /22



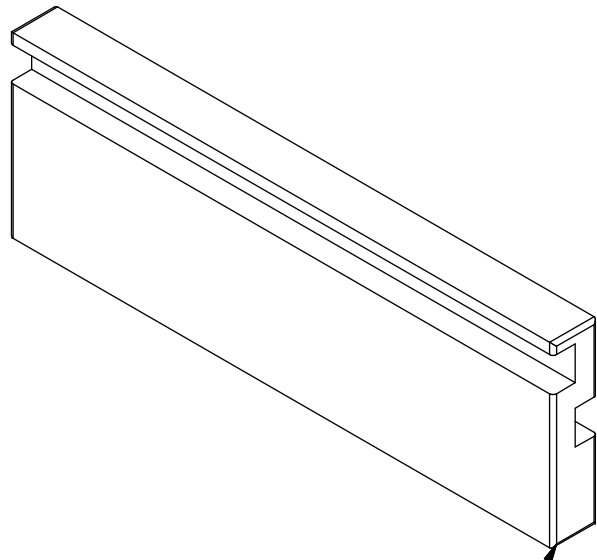
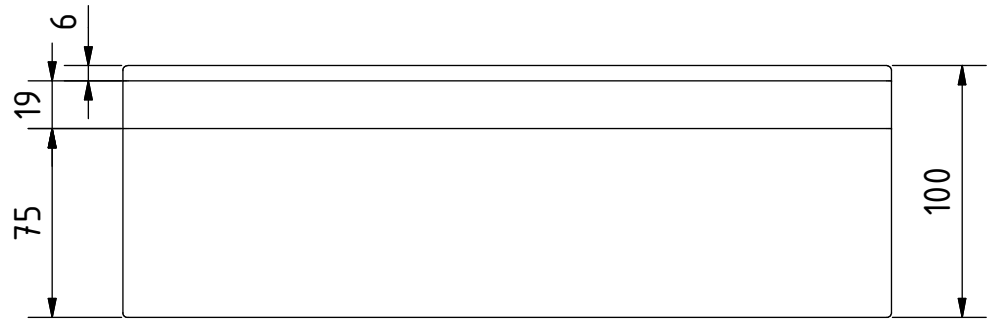
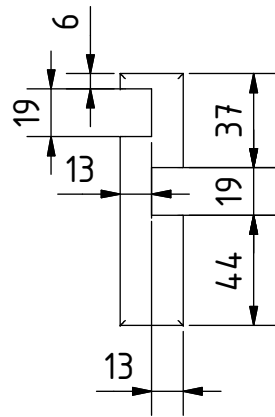

Rounded edge

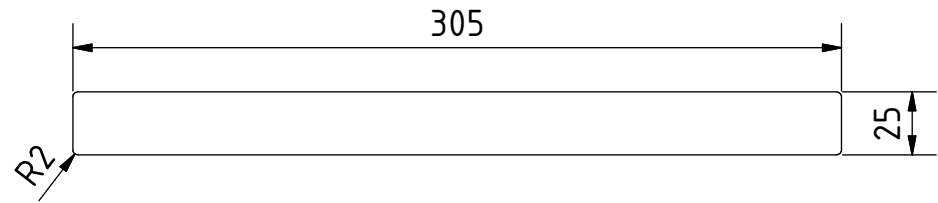

Note: All units in mm.

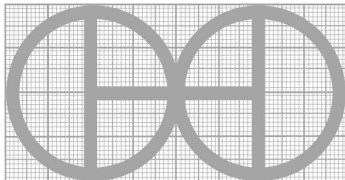
PROJECT	CREATED BY	APPROVED BY	DATE	VERSION
Wood router table - size 560 mm	J. Zeron	A. Morillo	14/10/2021	1.0
PART NAME	FILE NAME			POS
Sliding fence plate	Sliding fence plate.ipt			3.3
PUBLISHED BY		DOC. TYPE	MATERIAL	QUANTITY
OHO e.V.		Part	Hardwood	2
		LICENCE	SCALE	SHEET
		CC-BY-SA 4.0	1:3	17 /22

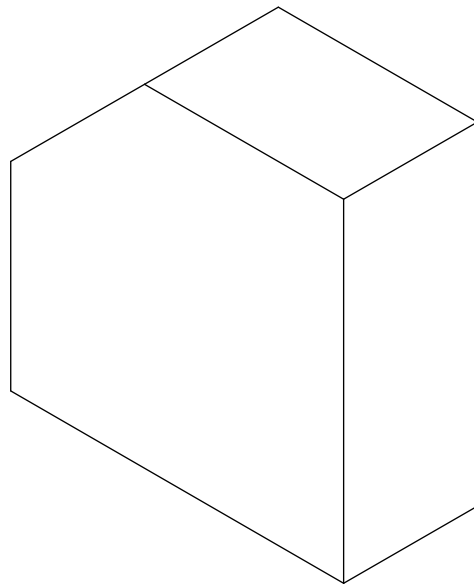
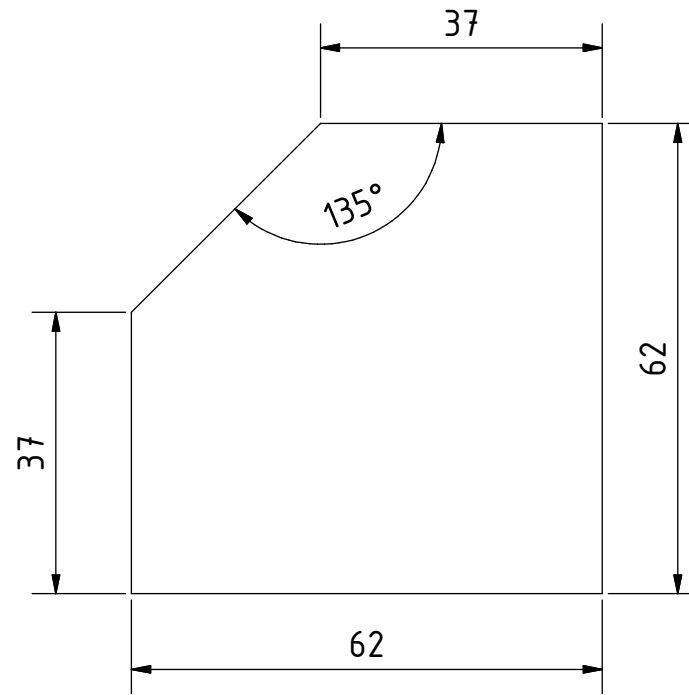
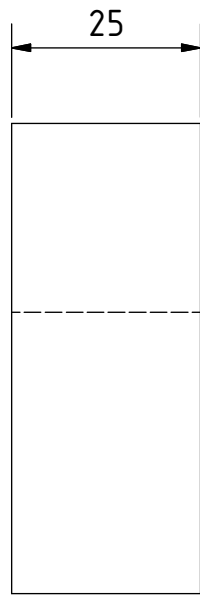

Note: All units in mm.

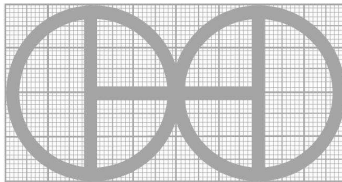
PROJECT	CREATED BY	APPROVED BY	DATE	VERSION
Wood router table - size 560 mm	J. Zeron	A. Morillo	14/10/2021	1.0
PART NAME	FILE NAME			POS
Beveled fence	Beveled fence.ipt			3.5
PUBLISHED BY		DOC. TYPE	MATERIAL	QUANTITY
OHO e.V.		Part	Hardwood	2
		LICENCE	SCALE	SHEET
		CC-BY-SA 4.0	1:1	18 /22

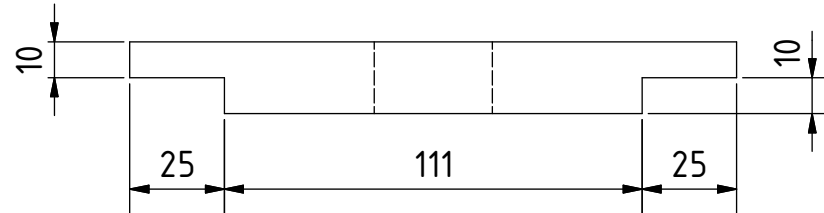
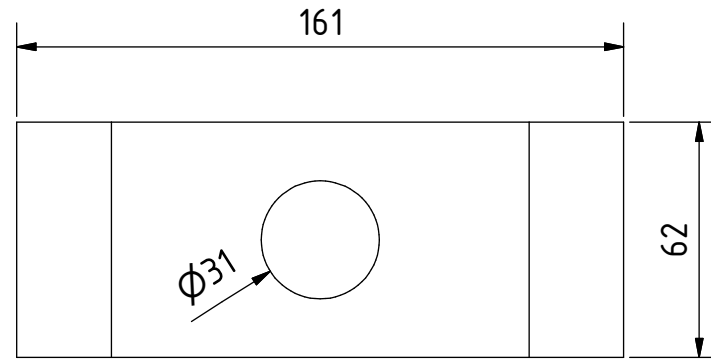
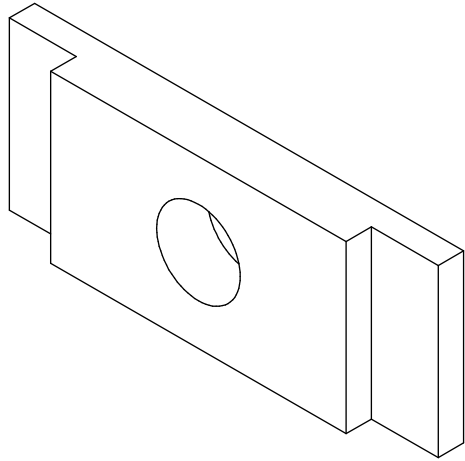

Note: All units in mm.

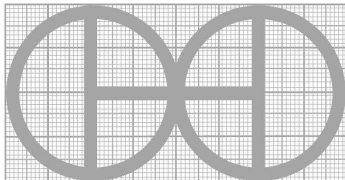
PROJECT	CREATED BY	APPROVED BY	DATE	VERSION
Wood router table - size 560 mm	J. Zeron	A. Morillo	14/10/2021	1.0
PART NAME	FILE NAME			POS
Rear vacuum box	Rear vacuum box.ipt			3.7
PUBLISHED BY		DOC. TYPE	MATERIAL	QUANTITY
OHO e.V.		Part	Hardwood	1
		LICENCE	SCALE	SHEET
		CC-BY-SA 4.0	1:2	19 /22

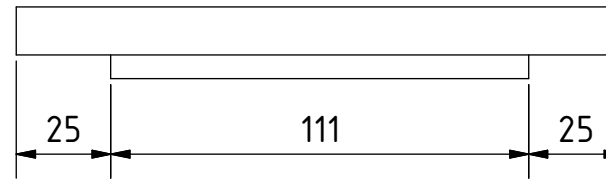
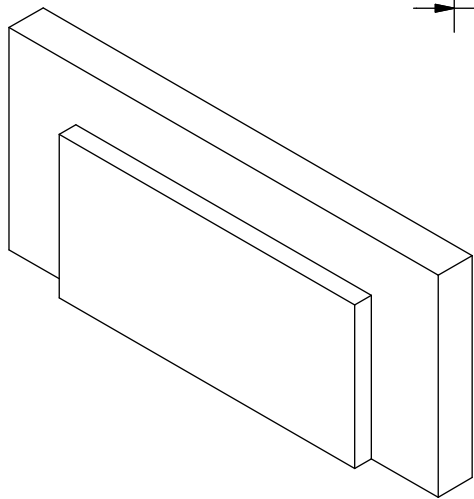
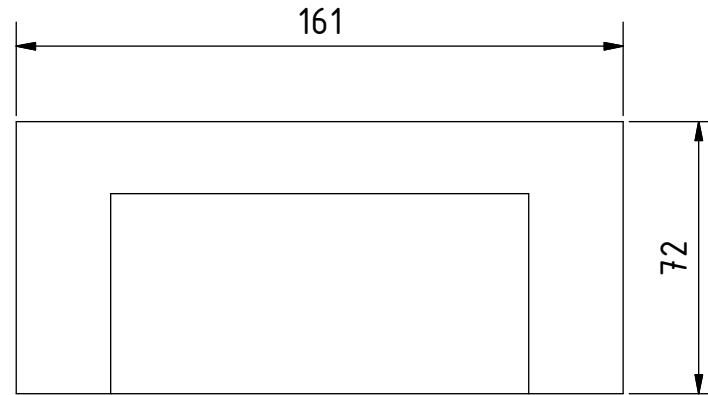
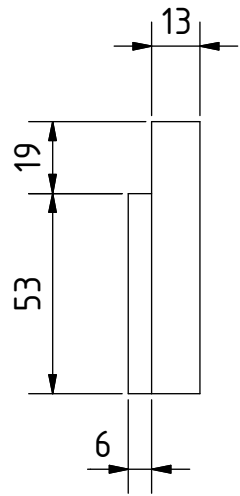

Note: All units in mm.

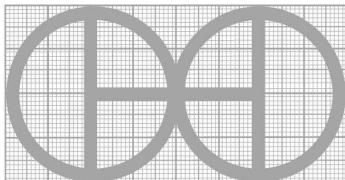
PROJECT	CREATED BY	APPROVED BY	DATE	VERSION
Wood router table - size 560 mm	J. Zeron	A. Morillo	14/10/2021	1.0
PART NAME	FILE NAME			POS
Top vacuum box	Top vacuum box.ipt			3.8
PUBLISHED BY		DOC. TYPE	MATERIAL	QUANTITY
OHO e.V.		Part	Hardwood	1
		LICENCE	SCALE	SHEET
		CC-BY-SA 4.0	1:2	20 /22

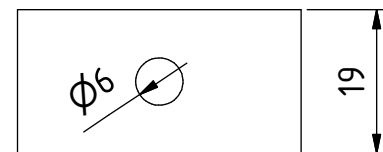
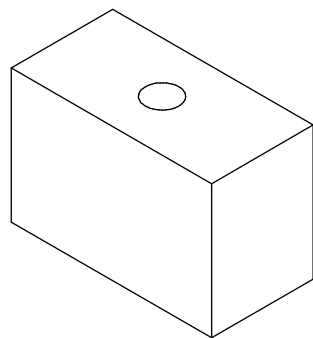
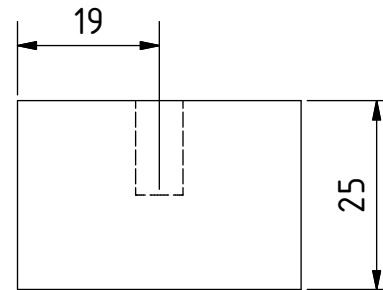
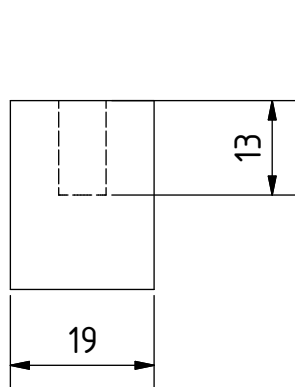

Note: All units in mm.

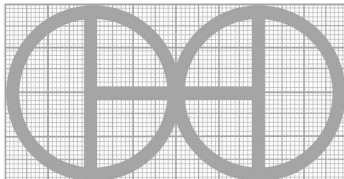
PROJECT	CREATED BY	APPROVED BY	DATE	VERSION
Wood router table - size 560 mm	J. Zeron	A. Morillo	14/10/2021	1.0
PART NAME	FILE NAME			POS
Ez-mount clamp riser A	Ez-mount clamp riser A.ipt			3.10
PUBLISHED BY		DOC. TYPE	MATERIAL	QUANTITY
OHO e.V.		Part	Hardwood	2
		LICENCE	SCALE	SHEET
		CC-BY-SA 4.0	1:1	21 /22

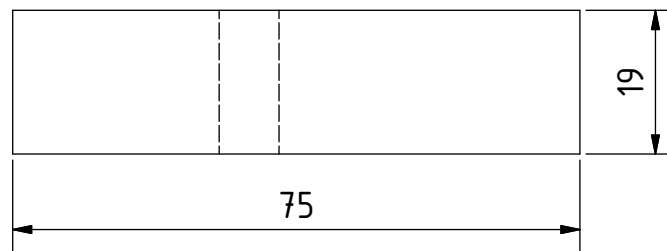
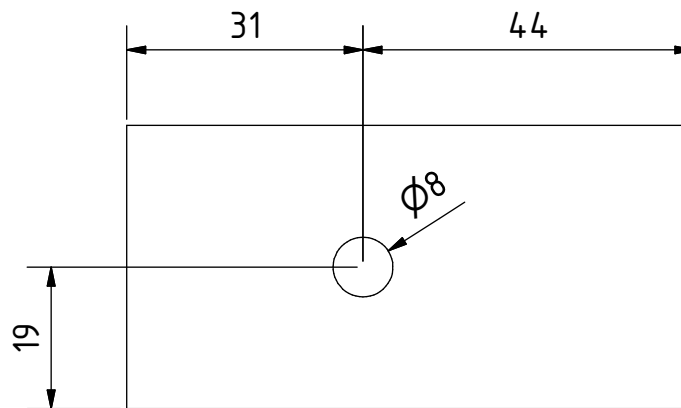
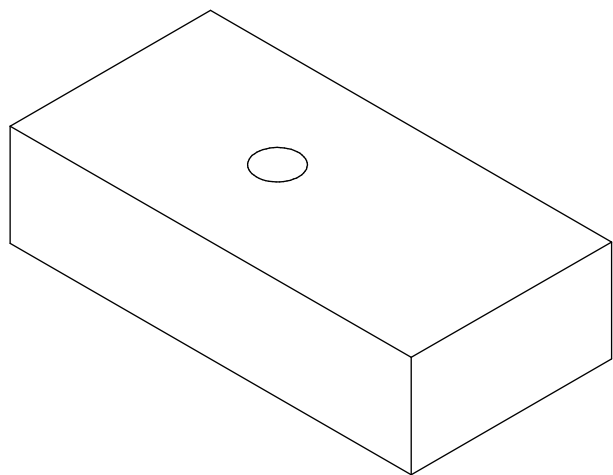

Note: All units in mm.

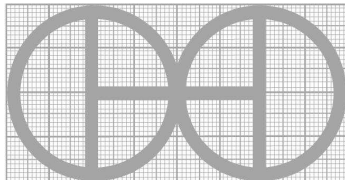
PROJECT	CREATED BY	APPROVED BY	DATE	VERSION
Wood router table - size 560 mm	J. Zeron	A. Morillo	14/10/2021	1.0
PART NAME	FILE NAME			POS
Ez-mount clamp riser B	Ez-mount clamp riser B.ipt			3.11
PUBLISHED BY		DOC. TYPE	MATERIAL	QUANTITY
OHO e.V.		Part	Hardwood	2
		LICENCE	SCALE	SHEET
		CC-BY-SA 4.0	1:1	22 /22