

ELEVATION (1 : 10)

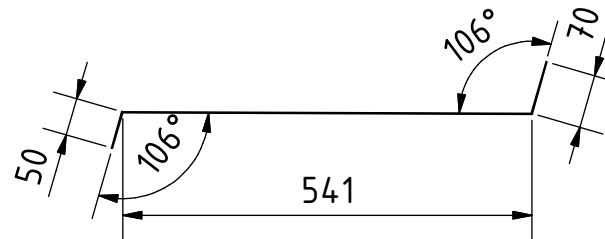
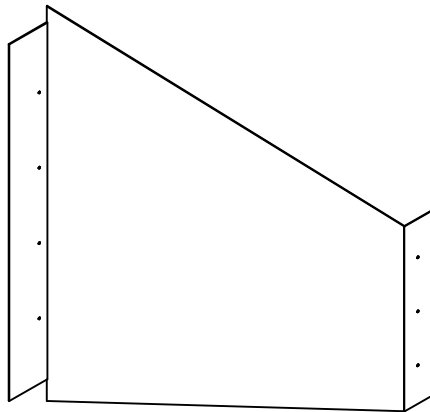
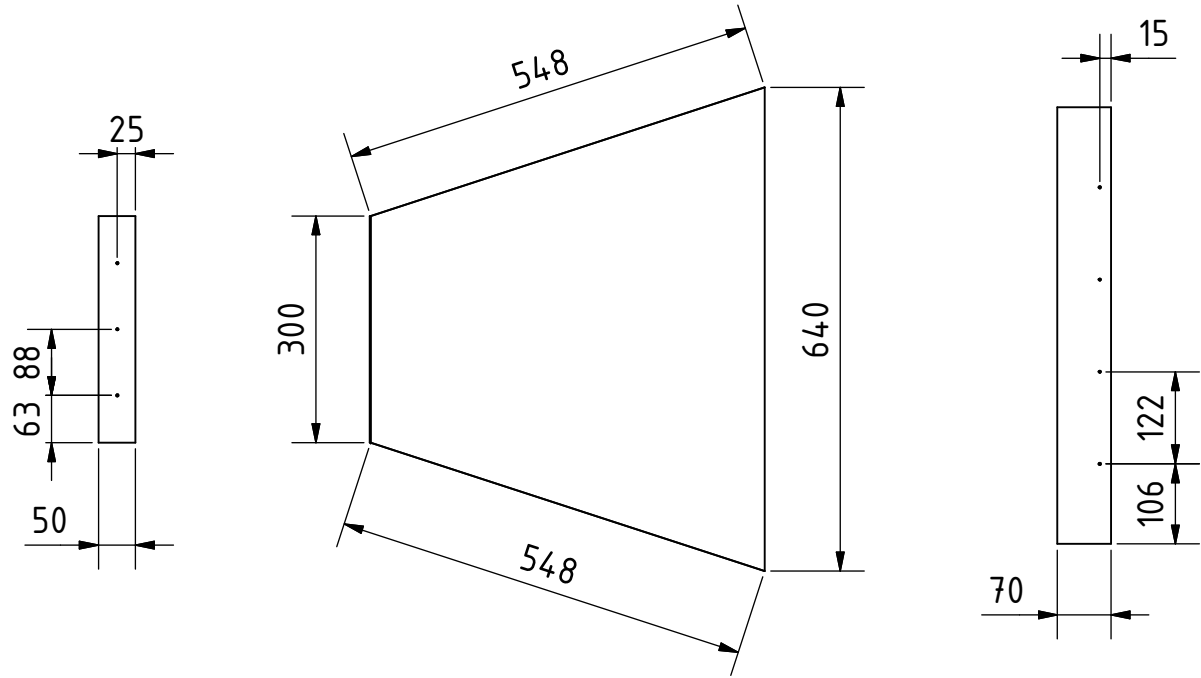
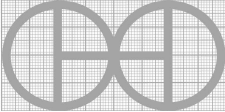

Note: All units in mm.

PROJECT	CREATED BY	APPROVED BY	DATE	VERSION
Batch Tray Dryer	J. Zeron	A. Morillo	10/08/2021	1.0
PART NAME	FILE NAME			POS
Side plate B	Side plate B.ipt			3.3
DEVELOPED BY	REDESIGNED BY	DOC. TYPE	MATERIAL	QUANTITY
		Part	18G Mild steel plate	2
Practical Action	OHO e.V.	LICENCE	SCALE	SHEET
		CC-BY-SA 4.0	1:10	16 /28