

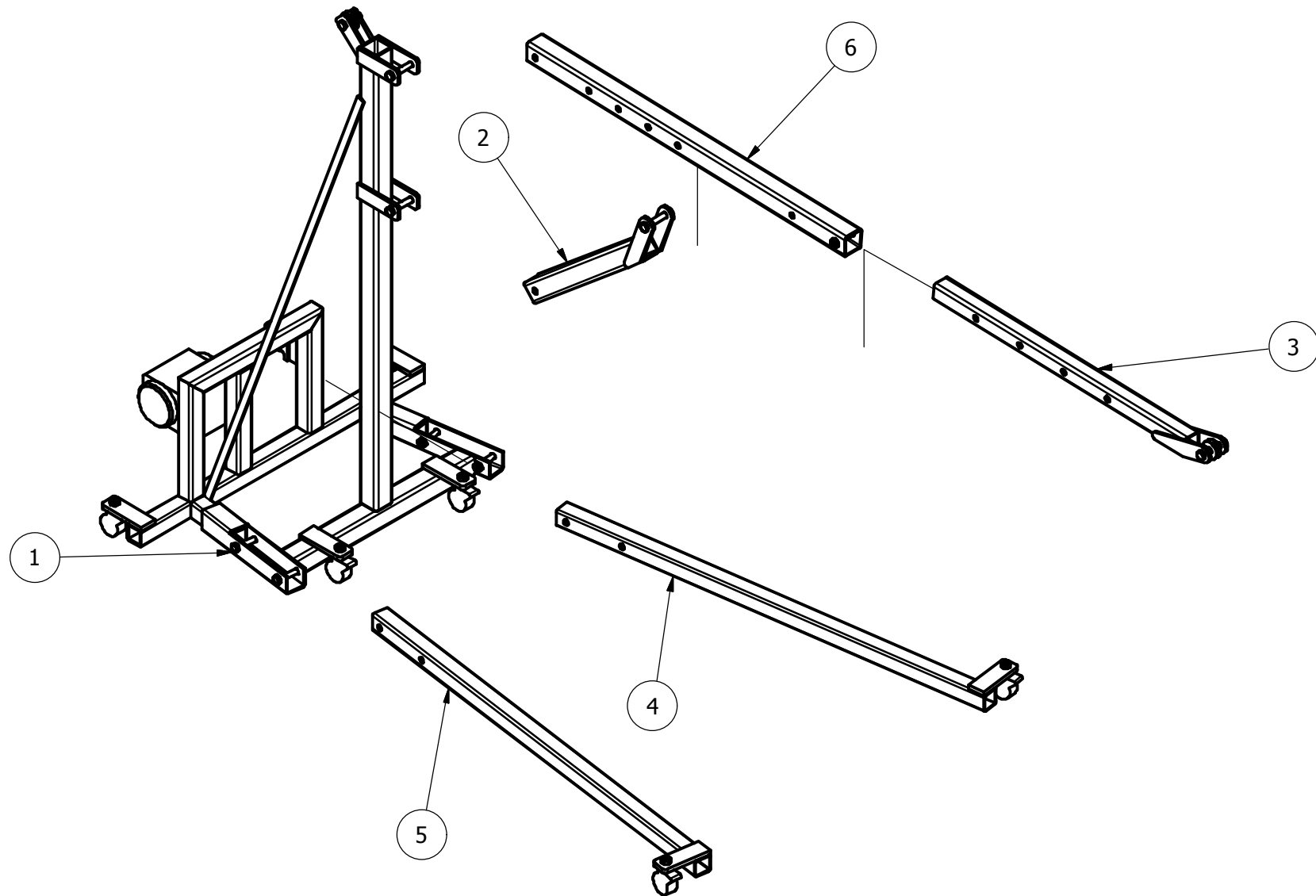

PROJECT		CREATED BY		APROVED BY					
Workshop Crane		A. MORILLO		D. JAEGER					
PART NAME		PART CODE		DOCUMENT TYPE		MATERIAL			
workshop-crane		A1		ASSEMBLY					
 <p>Open Source Ecology e.V. Knobelsdorffstr. 22 14059 Berlin www.ose-germany.de +49 (0) 30 / 92282426</p>		LICENCE		FILE NAME		VERSION		QUANTITY	
		CERN-OHL		workshop-crane.iam		1.0			
				SCALE		SHEET		DATE	
		1:15		1 / 11		08/12/20			



PROJECT		CREATED BY		APROVED BY	
Workshop Crane		A. MORILLO		D. JAEGER	
PART NAME		PART CODE		DOCUMENT TYPE	
workshop-crane		A2		ASSEMBLY	
 <p>Open Source Ecology e.V. Knobelsdorffstr. 22 14059 Berlin www.ose-germany.de +49 (0) 30 / 92282426</p>		LICENCE		VERSION	
		CERN-OHL		workshop-crane.iam	
		FILE NAME		QUANTITY	
		SCALE		SHEET	
		1:15		2 / 11	
				DATE	
				08/12/20	

## PARTS LIST

POS.	POS. OLD	QTY	PART NAME	FILE NAME	PART TYPE	SPECIFICATIONS	SHEET
A1			WORKSHOP CRANE	workshop-crane.iam			1
A2			WORKSHOP CRANE	workshop-crane.ipn			2
B1-B2			PART LIST	workshop-crane.csv			3-4
1		1	Main Frame	main-frame.iam			5
1			Main Frame	main-frame.ipn			6
1.1		1	Tube 50*50*4*1000 mm	DIN 50 x 50 x 4 00000001.ipt	PRODUCTION	EN 10210-2, STEEL A36	
1.2		2	Tube 50*50*4*172 mm	Varies	PRODUCTION	EN 10210-2, STEEL A36	
1.3		1	Tube 60*60*4*350 mm	DIN 60 x 60 x 4 00000004.ipt	PRODUCTION	EN 10210-2, STEEL A36	
1.4		2	Tube 50*50*4*360 mm	Varies	PRODUCTION	EN 10210-2, STEEL A36	
1.5		1	Tube 50*50*4*310 mm	DIN 50 x 50 x 4 00000006.ipt	PRODUCTION	EN 10210-2, STEEL A36	
1.6		1	Tube 50*50*4*470 mm	DIN 50 x 50 x 4 00000008.ipt	PRODUCTION	EN 10210-2, STEEL A36	
1.7		1	Tube 60*60*4*638 mm	DIN 60 x 60 x 4 00000009.ipt	PRODUCTION	EN 10210-2, STEEL A36	
1.8		4	flat steel bar 45*8*145 mm	Varies	PRODUCTION	EN 10058, STEEL A36	
1.9		1	Tube 60*60*4*1400 mm	DIN 60 x 60 x 4 00000014.ipt	PRODUCTION	EN 10210-2, STEEL A36	
1.10		1	Tube 60*60*4*350 mm	DIN 60 x 60 x 4 00000020.ipt	PRODUCTION	EN 10210-2, STEEL A36	
1.11		4	flat steel bar*145 mm	Varies	PRODUCTION	EN 10058, STEEL A36	
1.12		2	flat steel bar 25*5*1308 mm	Varies	PRODUCTION	EN 10058, STEEL A36	
1.13		2	flat steel bar 45*8*135 mm	Varies	PRODUCTION	EN 10058, STEEL A36	
1.14		2	Hex-Head Bolt		STANDARD	DIN 931-1 - M14 x 90	
1.15		11	Hex Nut		STANDARD	DIN 555-5 - M14	
1.16		1	Hex-Head Bolt		STANDARD	DIN 931-1 - M14 x 55	
1.17		4	Hex-Head Bolt		STANDARD	DIN 931-1 - M14 x 75	
1.18		4	WHEEL		BUY	CAP 200 KG	
1.19		1	PULLEY		BUY	D 50 mm, CABLE 10 mm	
1.20		1	Reducer		BUY	i = 1:100, SECURITY BRAKE	
1.21		1	Bearing		BUY	DEPENDS OF ITEM 1.20	
1.22		1	Hollow Shaft		BUY	DEPENDS OF ITEM 1.20	

PROJECT		CREATED BY	APPROVED BY		
Workshop Crane		A. MORILLO	D. JAEGER		
PART NAME		PART CODE	DOCUMENT TYPE	MATERIAL	
		B1	PART LIST		
 <p>Open Source Ecology e.V. Knobelsdorffstr. 22 14059 Berlin www.ose-germany.de +49 (0) 30 / 92282426</p>		LICENCE	FILE NAME	VERSION	QUANTITY
		CERN-OHL		1.0	
			SCALE	SHEET	DATE
				3 / 11	08/12/20

## PARTS LIST (CONTINUE)

POS.	POS. OLD	QTY	PART NAME	FILE NAME	PART TYPE	SPECIFICATIONS	SHEET
2		1	Pivot Arm	pivot-arm.iam			7
2.1		1	Tube 60*60*4*500 mm	DIN 60 x 60 x 4 00000001.ipt	PRODUCTION	EN 10210-2, STEEL A36	
2.2		2	flat steel bar 45*8*222 mm	Varies	PRODUCTION	EN 10058, STEEL A36	
2.3		1	Hex-Head Bolt		STANDARD	DIN 931-1 - M14 x 90	
2.4		1	Hex Nut		STANDARD	DIN 555-5 - M14	
3		1	Telescopic Tube	telescopic-tube.iam			8
3.1		2	flat steel bar 45*8*267 mm	Varies	PRODUCTION	EN 10058, STEEL A36	
3.2		1	Tube 50*50*4*890 mm	DIN 50x50x4 00000003.ipt	PRODUCTION	EN 10210-2, STEEL A36	
3.3		1	Hex-Head Bolt		STANDARD	DIN 931-1 - M14 x 80	
3.4		1	Hex Nut		STANDARD	DIN 555-5 - M14	
3.5		1	PULLEY		BUY	D 50 mm, CABLE 10 mm	
4		1	Lef Leg	left-leg.iam			9
4.1		1	Tube 50*50*4*1340 mm	DIN 50 x 50 x 4 00000002.ipt	PRODUCTION	EN 10210-2, STEEL A36	
4.2		1	flat steel bar 50*12*145 mm	DIN 50 x 12 00000003.ipt	PRODUCTION	EN 10058, STEEL A36	
4.3		1	WHEEL		BUY	CAP 200 KG	
4.4		1	Hex Nut		STANDARD	DIN 555-5 - M14	
5		1	Right Leg	right-leg.iam			10
5.1		1	Tube 50*50*4*1340 mm	DIN 50 x 50 x 4 00000001.ipt	PRODUCTION	EN 10210-2, STEEL A36	
5.2		1	flat steel bar 50*12*145 mm	DIN 50 x 12 00000003.ipt	PRODUCTION	EN 10058, STEEL A36	
5.3		1	WHEEL		BUY	CAP 200 KG	
5.4		1	Hex Nut		STANDARD	DIN 555-5 - M14	
6		1	Arm	arm.iam			11
6.1		1	Tube 60*60*4*1125 mm	DIN EN 10219-2 - 60 x 60 x 4 - 1125.ipt	PRODUCTION	EN 10210-2, STEEL A36	
6.2		1	Hex-Head Bolt		STANDARD	DIN 931-1 - M14 x 75	
6.3		1	Hex Nut		STANDARD	DIN 555-5 - M14	

PROJECT		CREATED BY	APROVED BY		
Workshop Crane		A. MORILLO	D. JAEGER		
PART NAME		PART CODE	DOCUMENT TYPE	MATERIAL	
		B2	PART LIST		
 <p>Open Source Ecology e.V. Knobelsdorffstr. 22 14059 Berlin www.ose-germany.de +49 (0) 30 / 92282426</p>		LICENCE	FILE NAME	VERSION	QUANTITY
		CERN-OHL		1.0	
			SCALE	SHEET	DATE
				4 / 11	08/12/20

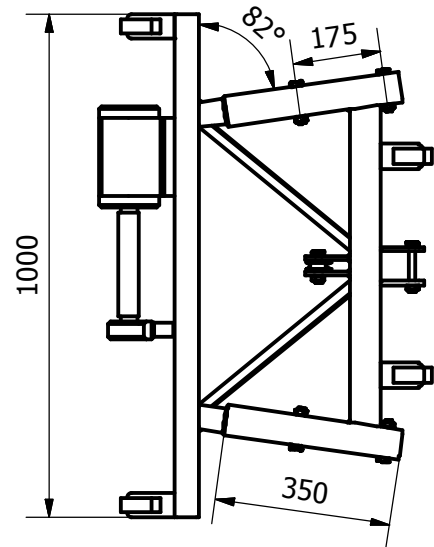
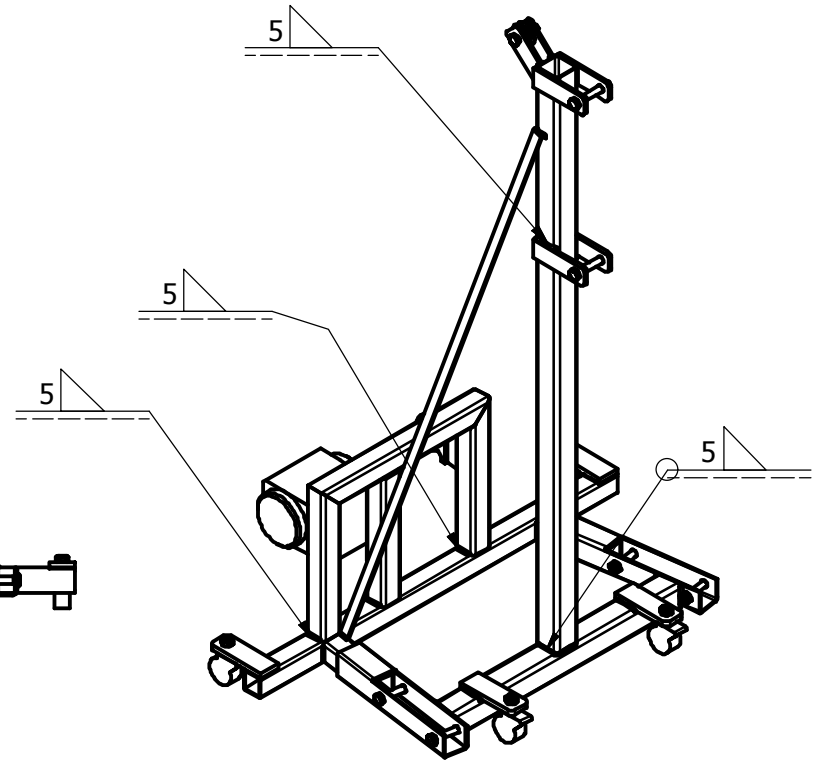
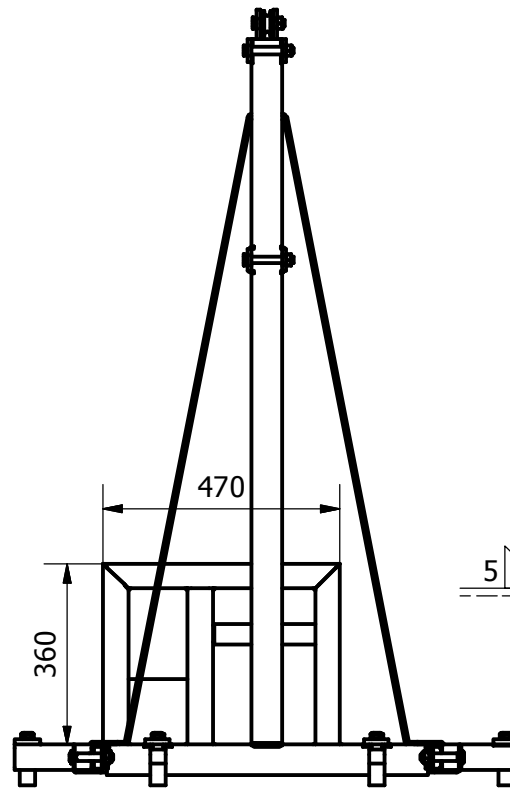
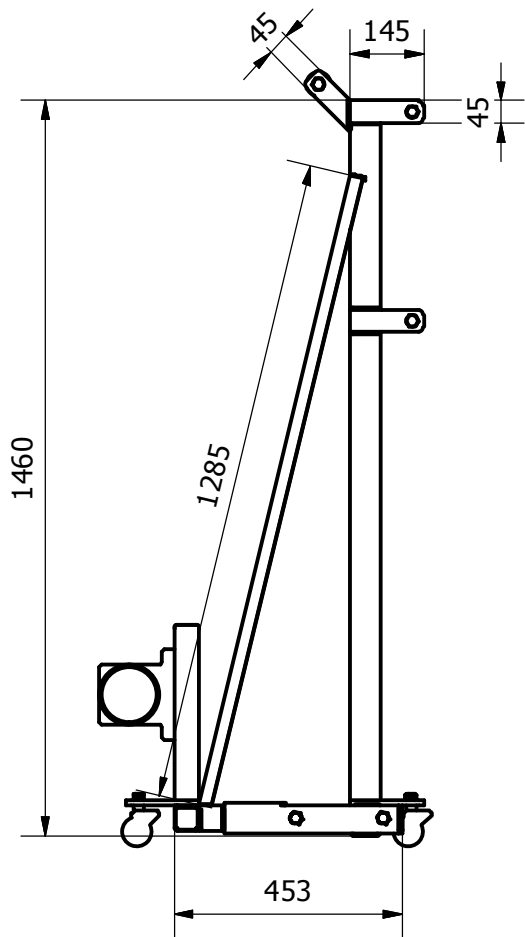

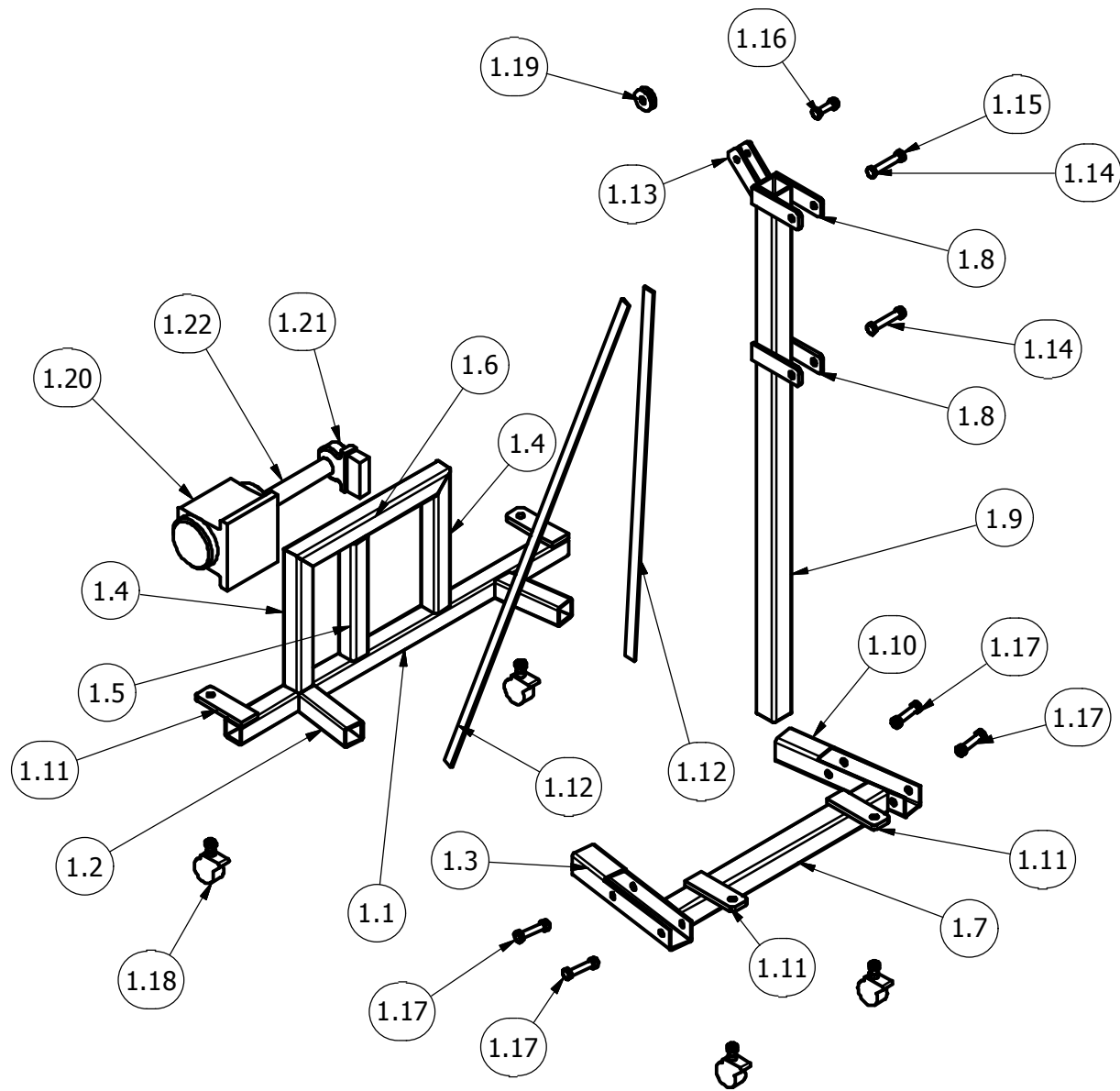

PROJECT	CREATED BY	APROVED BY		
Workshop Crane	A. MORILLO	D. JAEGER		
PART NAME	PART CODE	DOCUMENT TYPE	MATERIAL	
main-frame	1	ASSEMBLY		
 OPEN SOURCE ECOLOGY GERMANY	LICENCE	FILE NAME	VERSION	QUANTITY
	CERN-OHL	main-frame.iam	1.0	1
		SCALE	SHEET	DATE
		1:15	5 / 11	08/12/20

Open Source Ecology e.V.  
 Knobelsdorffstr. 22  
 14059 Berlin  
 www.ose-germany.de  
 +49 (0) 30 / 92282426

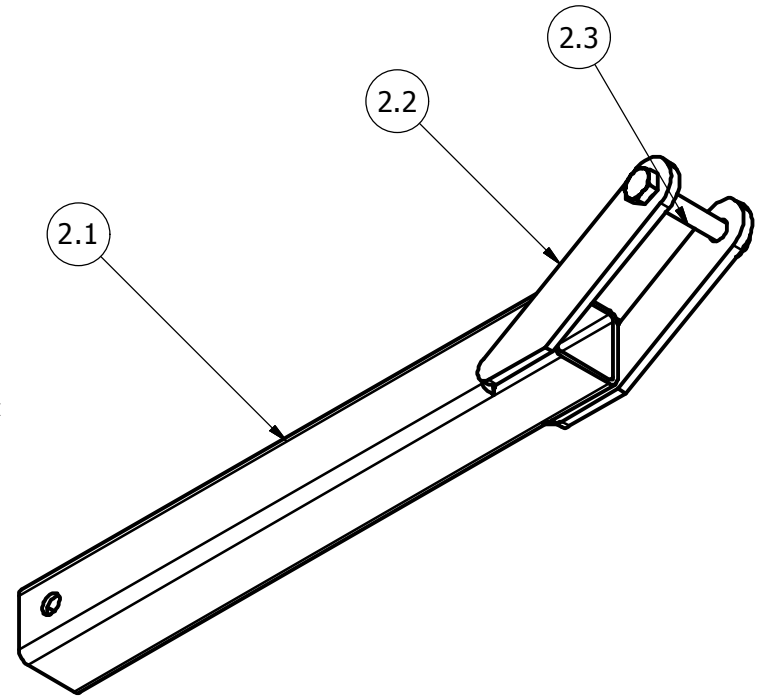
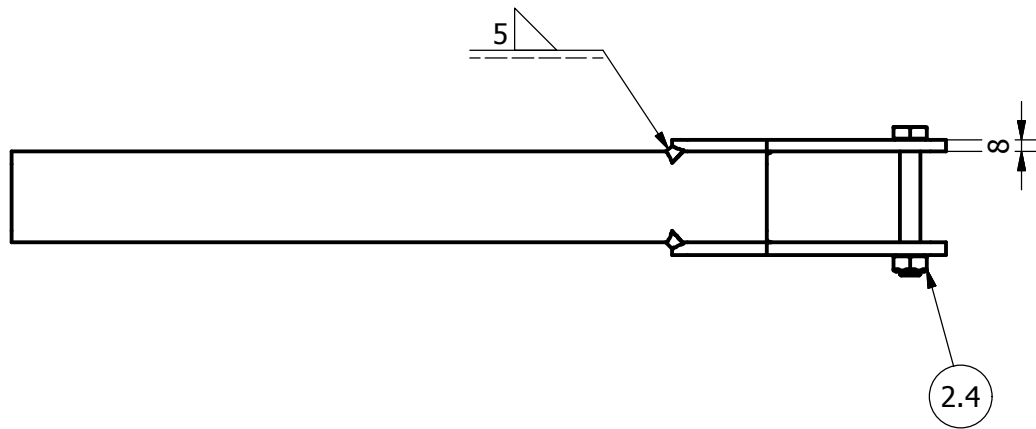
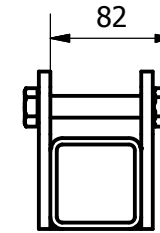
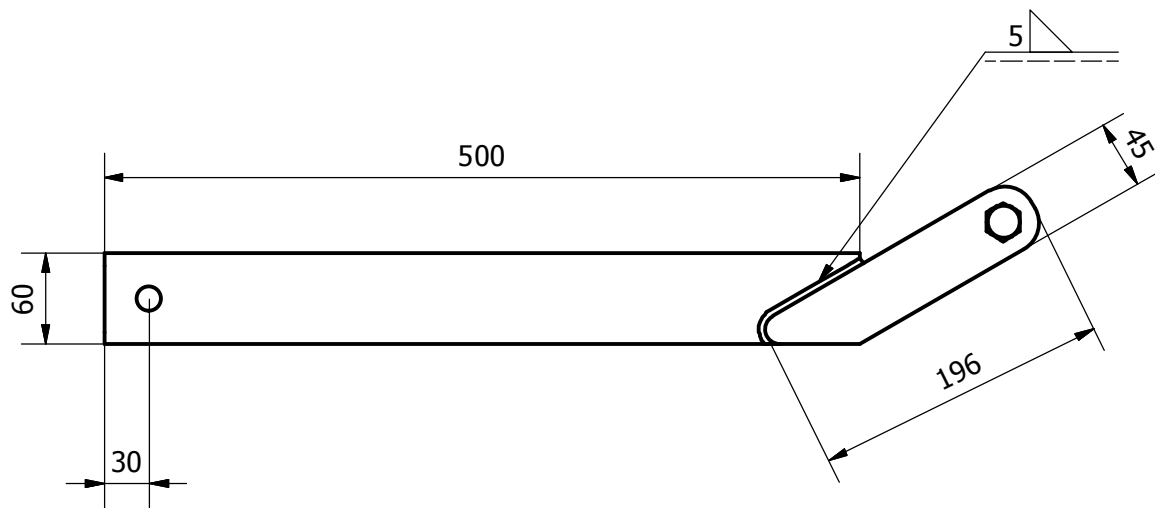

PROJECT		CREATED BY		APROVED BY	
Workshop Crane		A. MORILLO		D. JAEGER	
PART NAME		PART CODE		DOCUMENT TYPE	
main-frame		1		ASSEMBLY	
 Open Source Ecology e.V. Knobelsdorffstr. 22 14059 Berlin <a href="http://www.ose-germany.de">www.ose-germany.de</a> +49 (0) 30 / 92282426		LICENCE		VERSION	
		CERN-OHL		1.0	
		FILE NAME		QUANTITY	
		main-frame.iam		1	
		SCALE		SHEET	
		1:15		6 / 11	
				DATE	
				08/12/20	



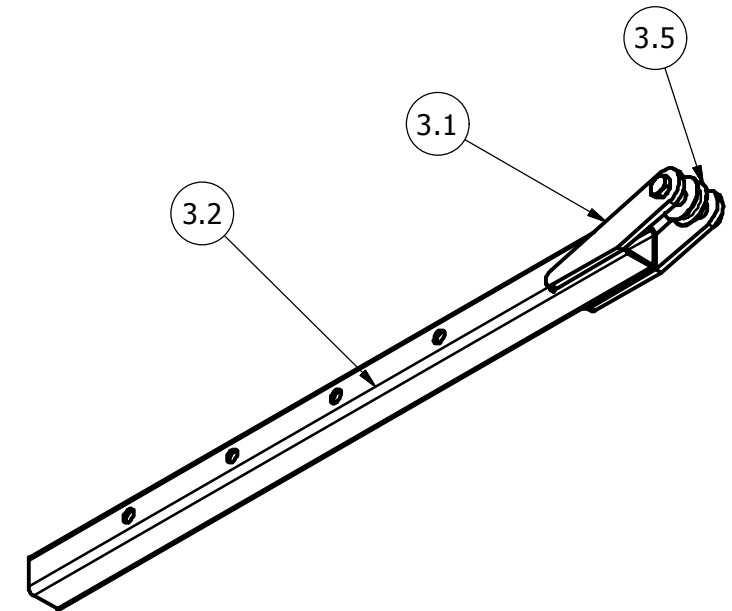
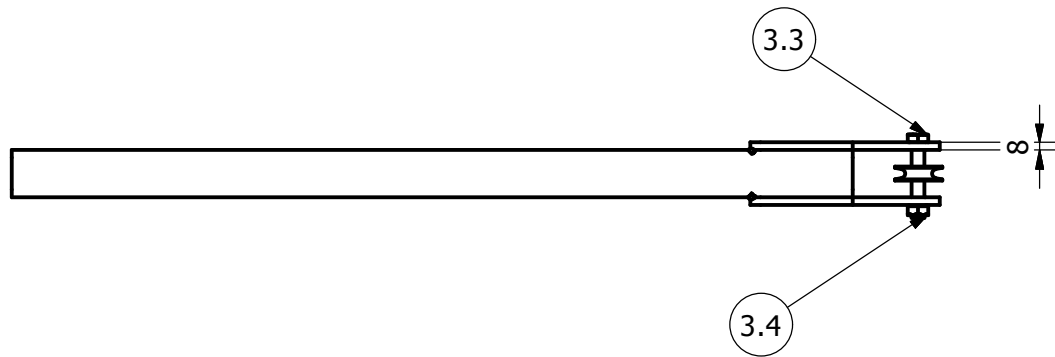
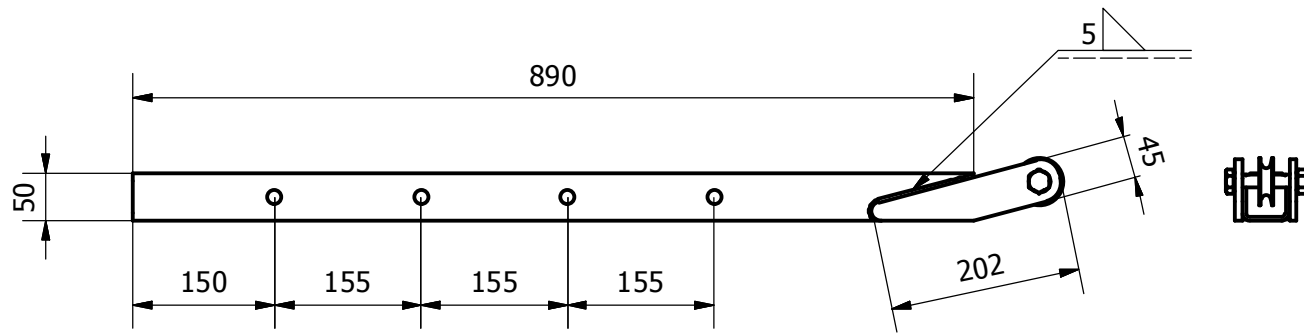

PROJECT		CREATED BY		APPROVED BY	
Workshop Crane		A. MORILLO		D. JAEGER	
PART NAME		PART CODE		DOCUMENT TYPE	
pivot-arm		2		ASSEMBLY	
 Open Source Ecology e.V. Knobelsdorffstr. 22 14059 Berlin <a href="http://www.ose-germany.de">www.ose-germany.de</a> +49 (0) 30 / 92282426		LICENCE		VERSION	
		CERN-OHL		1.0	
		FILE NAME		QUANTITY	
		pivot-arm.iam		1	
		SCALE		SHEET	
		1:5		7 / 11	
				DATE	
				08/12/20	



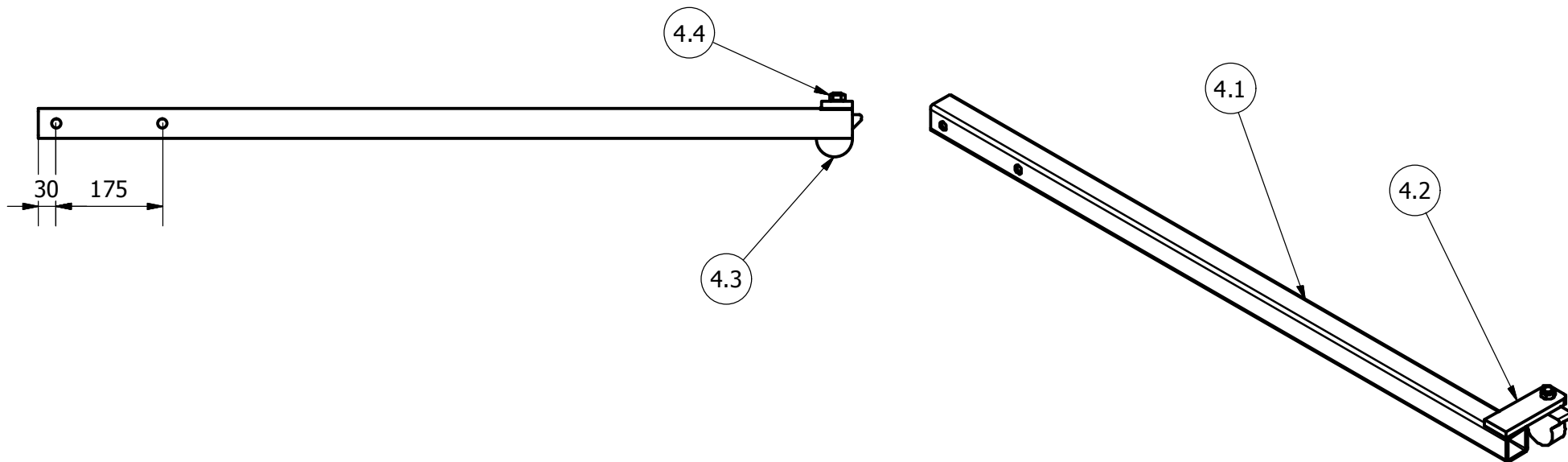
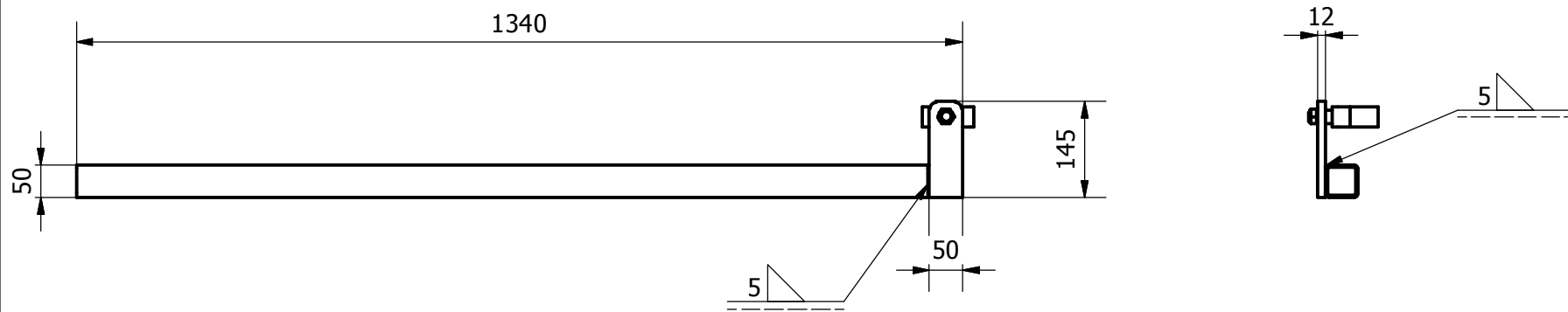

PROJECT	CREATED BY	APROVED BY		
Workshop Crane	A. MORILLO	D. JAEGER		
PART NAME	PART CODE	DOCUMENT TYPE	MATERIAL	
telescopic-tube	3	ASSEMBLY	STEEL A36	
 Open Source Ecology e.V. Knobelsdorffstr. 22 14059 Berlin <a href="http://www.ose-germany.de">www.ose-germany.de</a> +49 (0) 30 / 92282426	LICENCE	FILE NAME	VERSION	QUANTITY
	CERN-OHL	telescopic-tube.iam	1.0	1
		SCALE	SHEET	DATE
	1:8	8 / 11	08/12/20	





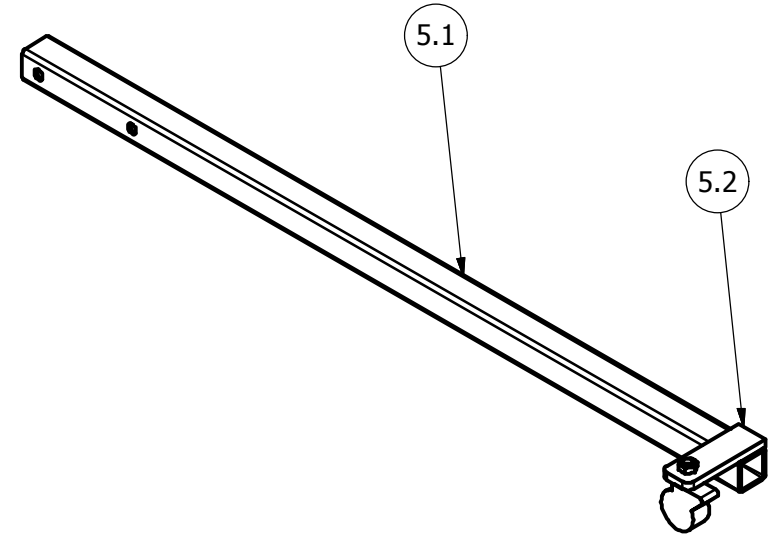
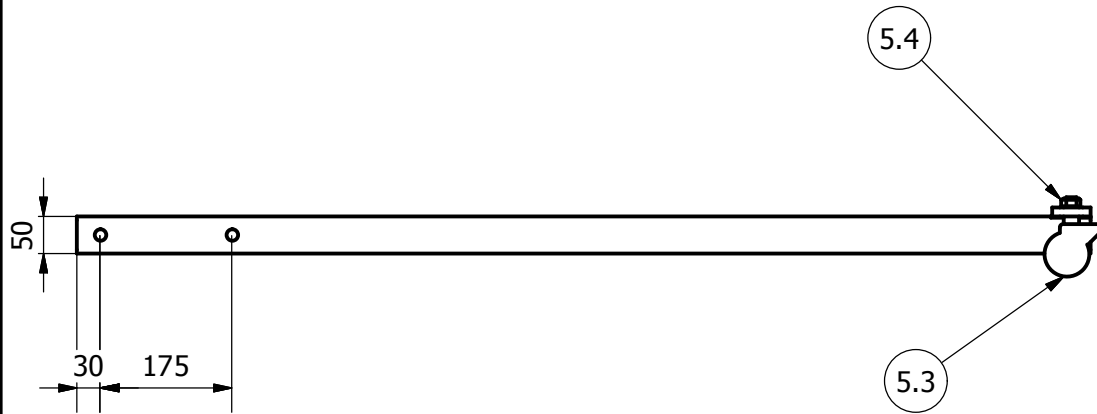
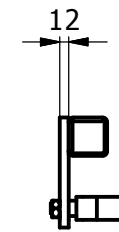
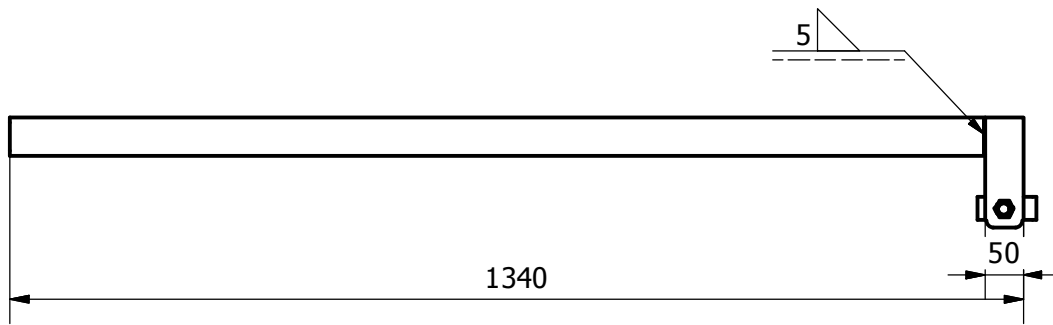

PROJECT	CREATED BY	APROVED BY		
Workshop Crane	A. MORILLO	D. JAEGER		
PART NAME	PART CODE	DOCUMENT TYPE	MATERIAL	
left-leg	4	ASSEMBLY	STEEL A36	
 Open Source Ecology e.V. Knobelsdorffstr. 22 14059 Berlin <a href="http://www.ose-germany.de">www.ose-germany.de</a> +49 (0) 30 / 92282426	LICENCE	FILE NAME	VERSION	QUANTITY
	CERN-OHL	left-leg.iam	1.0	1
			SCALE	SHEET
		1:10	9 / 11	08/12/20

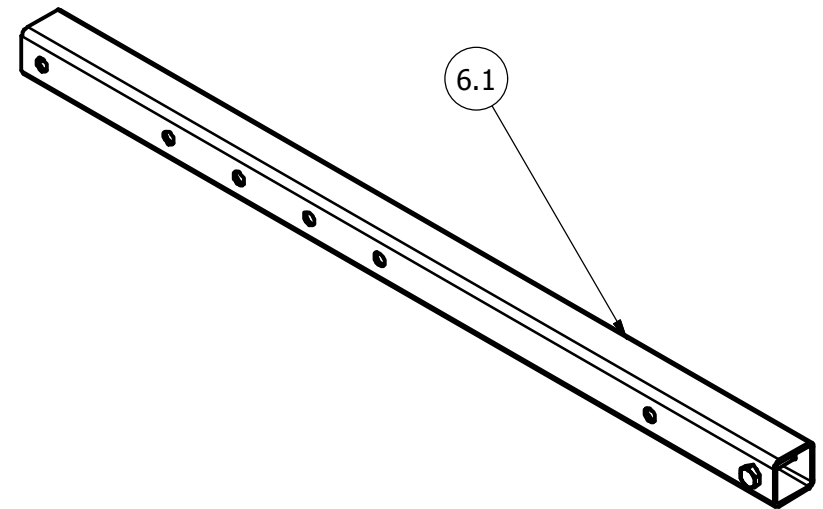
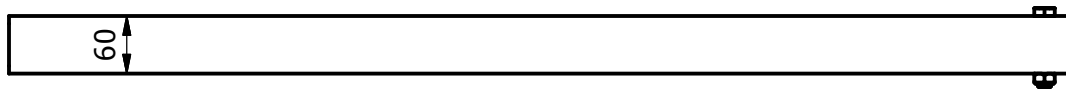
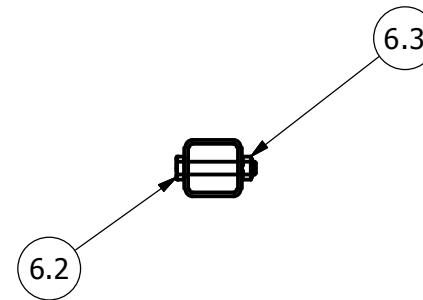
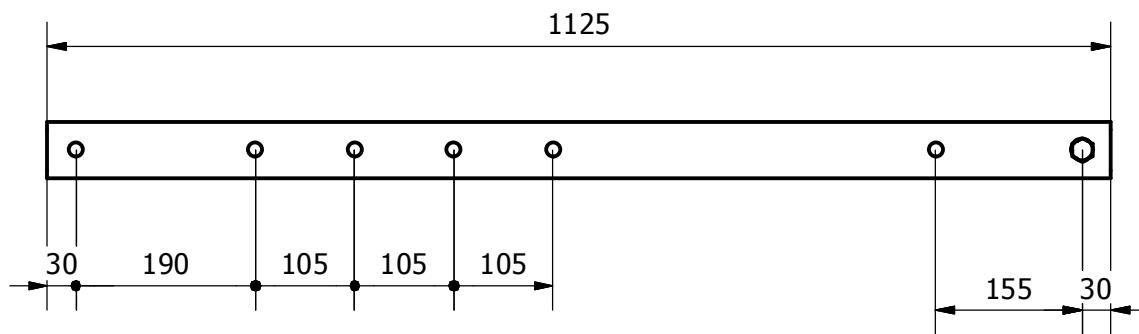

PROJECT	CREATED BY	APROVED BY		
Workshop Crane	A. MORILLO	D. JAEGER		
PART NAME	PART CODE	DOCUMENT TYPE	MATERIAL	
right-leg	5	ASSEMBLY	STEEL A36	
 Open Source Ecology e.V. Knobelsdorffstr. 22 14059 Berlin <a href="http://www.ose-germany.de">www.ose-germany.de</a> +49 (0) 30 / 92282426	LICENCE	FILE NAME	VERSION	QUANTITY
	CERN-OHL	right-leg.iam	1.0	1
			SCALE	SHEET
		1:10	10 / 11	08/12/20



PROJECT		CREATED BY		APROVED BY		
Workshop Crane		A. MORILLO		D. JAEGER		
PART NAME		PART CODE	DOCUMENT TYPE		MATERIAL	
arm		6	ASSEMBLY		STEEL A36	
 Open Source Ecology e.V. Knobelsdorffstr. 22 14059 Berlin <a href="http://www.ose-germany.de">www.ose-germany.de</a> +49 (0) 30 / 92282426		LICENCE	FILE NAME		VERSION	QUANTITY
		CERN-OHL	arm.iam		1.0	1
			SCALE	SHEET	DATE	
	1:8	11 / 11	08/12/20			